

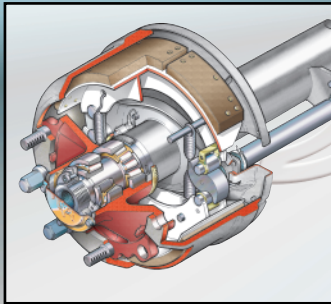

MERITOR™



Product Index



Axles

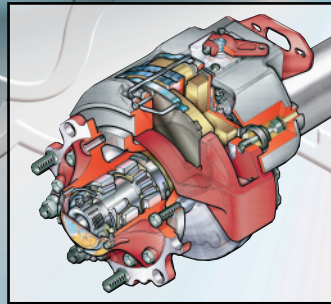

Brakes

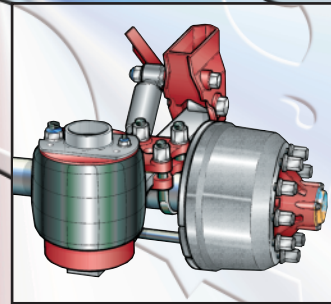

Suspensions

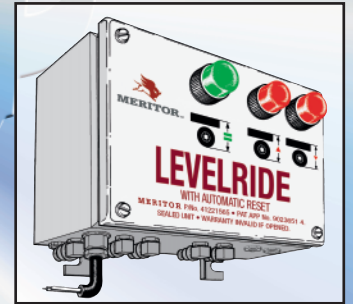

Ancillaries



MERITORTM



Meritor Trailer Axles

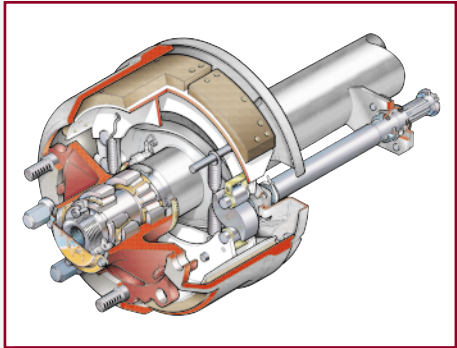

The world wide automotive experience and product development of Meritor HVS Ltd has produced a range of trailer axles and running gear of the highest quality and proven reliability.

Meritor HVS Ltd have ultimate control over the entire Engineering and Production process: this ensures that the customer gets proven maximum strength at minimum weight, resulting in the most cost effective trailer axle range available.

TM Axles

TE Axles

LM Axles

LMC Axles



MERITOR™



Meritor Self Steering Axles

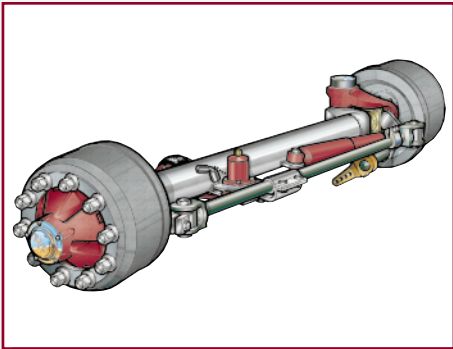

Meritor has been promoting the use of steering axles for many years, particularly for maximum length tri-axle trailers which must meet turning circle requirements.

Meritor self-steer axles give tri-axle stability, reduced tyre wear, increased manoeuvrability and have maximum interchangeability with Meritor fixed axles.

TM Series

TE Series

Command Steer



MERITOR™



Meritor Disc Brakes

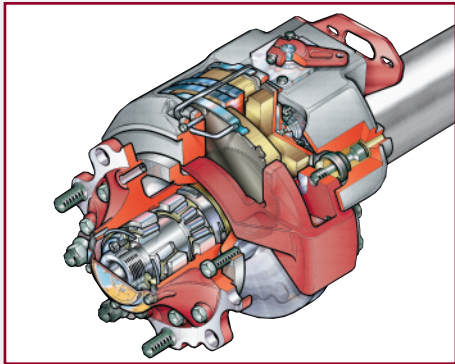

The new breed of Meritor trailer disc brakes gives the operator considerable improvements over the standard trailer drum brake with faster actuation, more consistent brake force and low maintenance.

LM DX195

LMC DX195

TM DX195



MERITOR™



Meritor Brakes – Associated Items

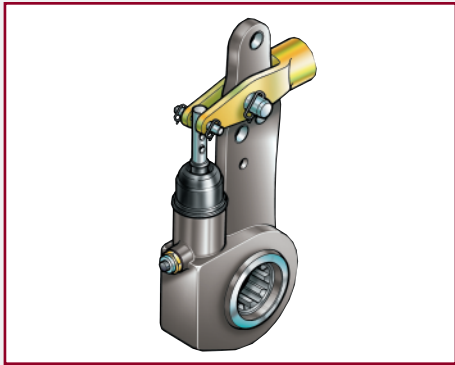

As the leading supplier of automatic slack adjusters and foundation brakes in North America, Meritor understands their delicate relationship. In today's competitive climate, successful businesses need to reduce costs and increase

productivity. The Meritor ASA, proven in hundreds of billions of service miles, will help you achieve these goals.

Meritor spring brakes, in addition to providing a means of applying the trailer Service brake, provide a SAFE and RELIABLE trailer Parking brake.

Slack Adjusters

Spring Brakes

Long Stroke Brake



MERITOR™



Meritor Trailer Suspensions

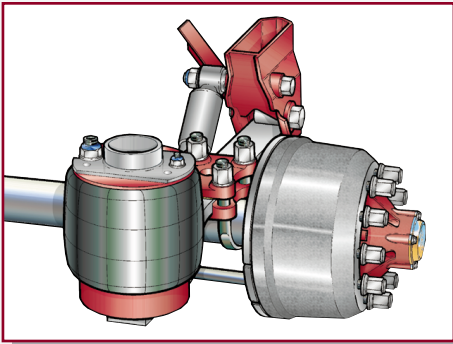

There are many air suspension systems on the market. Meritor offers two ranges - Flexair and Indair. Flexair retains the traditional beam axle while Indair offers fully independent wheel

stations and is the most advanced system currently available.

Meritor's SMT Suspension is one of the lightest and simplest mechanical suspensions available today.

Flexair

Indair

SMT Mechanical



MERITOR™



Meritor Ancillaries

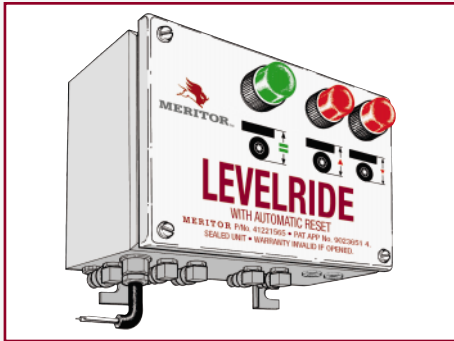

Landing Legs

Levelride

Autolift/Autodrop