

2011
2012

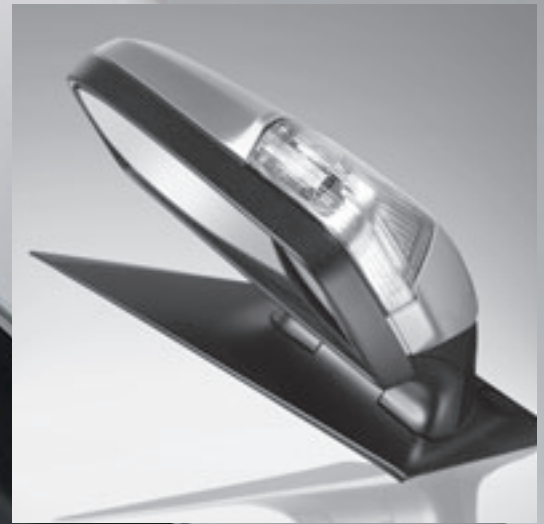

reflecting your visions.

MEKRA
LANG



Wir geben Visionen



Seit nunmehr drei Generationen ist MEKRA LANG ein aktiver und überzeugender Impulsgeber für Rundum-Sichtsysteme bei Nutzfahrzeugen. Erfahrung und Professionalität haben das Familienunternehmen zu einem Global-Player mit 17 Standorten werden lassen. Als verlässlicher Systemlieferant der Nutzfahrzeugindustrie ist MEKRA LANG für die hohe Fertigungstiefe und serviceorientierte Kundennähe bekannt. Natürlich rundum zertifiziert und dank der ständigen technischen Weiterentwicklung ein wichtiger Innovationstreiber für die gesamte Branche. Wir freuen uns auf die Herausforderung Ihre Visionen mit Kompetenz und Know-how umzusetzen - *"reflecting your visions"*.



For three generations, MEKRA LANG has now been providing active impulses for all-round-vision systems for commercial vehicles. Experience and our professional approach were what turned this family-run company into a global player with 17 business locations. As a reliable supplier of systems to the commercial vehicle industry, MEKRA LANG has an excellent reputation for a high degree of manufacturing expertise and its service-orientated approach of always putting the customer first. Of course, we have all the necessary certificates, and thanks to a process of continuous further technical development, we are a significant driver of innovations for the entire sector. We look forward to the challenge of turning your visions into a reality with competence and know-how - *reflecting your visions*.



Depuis trois générations, la société MEKRA LANG est très active, performante et innovatrice, dans les systèmes de rétro vision pour véhicules utilitaires. Son expérience et son savoir-faire a mené l'entreprise familiale à une dimension internationale avec 17 sites. La société MEKRA LANG est un fournisseur dans le domaine de l'industrie du véhicule utilitaire, sur lequel on peut compter, grâce à sa haute technologie et sa recherche permanente de la satisfaction du client. La société MEKRA LANG est certifiée pour l'ensemble de ses activités. Par sa constante évolution technologique la société MEKRA LANG est devenue un des leaders dans son secteur. Sa compétence et son savoir faire lui permet de relever vos défis et de réaliser vos projets - *"reflecting your visions"*.



Da tre generazioni la società MEKRA LANG è particolarmente attiva, efficiente ed innovatrice nel settore degli specchi retrovisori per veicoli commerciali. La sua esperienza e professionalità hanno condotto questa impresa familiare a diventare una multinazionale con 17 filiali in tutto il mondo. La società MEKRA LANG è l'azienda nel campo dell'industria del veicolo commerciale sulla quale potete contare, grazie alla sua alta tecnologia e alla sua costante ricerca orientata verso la soddisfazione del Cliente. La società MEKRA LANG ha ottenuto certificazioni di qualità per l'insieme delle sue attività. In seguito alla sua costante evoluzione tecnologica, la società MEKRA LANG è divenuta uno dei leader nel suo settore. La sua competenza ed esperienza, le permettono di accettare le Vostre sfide e realizzare i Vostri progetti - *"reflecting your visions"*.



Por três gerações, a MEKRA LANG tem sido um inovador ativo e convincente no campo de "all-around-vision" para veículos comerciais. Com experiência e profissionalismo, esta empresa familiar se tornou uma multinacional com 17 instalações em todo o mundo. MEKRA LANG é um fornecedor de confiança na indústria de veículos comerciais, conhecido por sua ampla produção e por trabalhar orientada a colocar o cliente em primeiro lugar. Naturalmente, nós temos todos os certificados necessários. O padrão técnico elevado e as inovações da MEKRA LANG influem nos padrões do setor inteiro. Nós aceitamos o desafio de tornar suas visões em realidade com competência e conhecimento - *"reflecting your visions"*.



Desde hace tres generaciones MEKRA LANG es un innovador activo y convincente en el campo de sistemas de "vision alrededor" en vehículos industriales. Con experiencia y profesionalidad esta empresa familiar ha llegado a ser una multinacional con 17 instalaciones en todo el mundo. MEKRA LANG es un seguro y fiable fabricante para la industria del vehículo industrial, conocido por su amplia producción y orientación de servicio hacia el cliente. La empresa está completamente certificada y gracias a su constante desarrollo técnico se ha tornado en importante impulsor de innovaciones para todo el ramo. Nos alegramos de asumir el reto de realizar sus nuevos proyectos con nuestra experiencia y saber - *"reflecting your visions"*.





shaping

Gestalt

 Sedan tri generationer, är MEKRA LANG en ledande aktör inom siktsystem för nyttofordon. Erfarenhet och professionalism har gjort familjeföretaget till en global spelare med verksamhetsenheter på 17 platser i världen. Som tillförlitlig leverantör till fordonsindustrin är Mekra känd för sin serviceorienterade närhet till kund. MEKRA LANG är ett kvalitets och miljöcertifierat företag. Tack vare den ständiga tekniska vidareutvecklingen inom gruppen, har MEKRA LANG blivit en viktig pådrivare av innovationer för hela branschen. Vi ser med glädje fram emot att få förverkliga Era visioner med hjälp av vår kompetens och kunnande d.v.s. - *"reflecting your visions"*.

 Firma MEKRA LANG je již po dobu tří generací aktivní a přesvědčivý výrobce kompletních výhledových systémů u užitkových vozidel. Zkušenost a profesionalita dovedla tento rodinný podnik k celosvětovému působení na 17 stanovištích. Jako spolehlivý dodavatel výhledových systémů v oblasti užitkových vozidel je MEKRA LANG známá pro svou vysokou produktivitu a pro kompletní servis zákazníkovi. Je přirozeně kompletně certifikována. Vysoký technický standard a inovace od frmy MEKRA LANG daly této branži rozhodující směr. Těšíme se na výzvu, Vaše představy uskutečnit odborně, s kompetencí a s Know-how - *"reflecting your visions"*.

 Вот уже на протяжении трёх поколений от фирмы MEKRA LANG исходят активные и убедительные импульсы для области систем обозрения для полезных транспортных средств. Большой опыт и высокая профессиональность возвели это семейное предприятие в статус глобального предприятия с 17 филиалами во всём мире. Являясь надёжным поставщиком систем для промышленности полезных транспортных средств, фирма MEKRA LANG известна высококачественной продукцией и отличным сервисом и обслуживанием своих клиентов. Разумеется фирма сертифицирована и благодаря постоянному техническому прогрессу является важным рычагом для всей области. Мы будем рады с помощью нашей компетентности и технологии воплотить в жизнь Ваши намерения и идеи, или говоря по англ. - *"reflecting your visions"*.

 MEKRA LANG üç kuşaktır ticari araçlar için çevre görüş sistemleri üretiminde etkin rol oynamaktadır. Tecrübemiz ve profesyonel yaklaşımımız bu aile şirketini bir dünya şirketine dönüştürerek dünyanın çeşitli bölgelerinde 17 üretim merkezi kurmamıza olanak vermiştir. Ticari araç sanayinde güvenilir tedarikçi MEKRA LANG yüksek kaliteli üretim uzmanlığı ile ün yapmış ve müşteriyi her zaman ilk sıraya koyan bir yaklaşımı benimsemiştir. Gerekli tüm sertifikalara sahip olan MEKRA LANG'ın teknik standartları ve yenilikleri tüm sektörün standartları üzerinde etkili olmaktadır. Vizyonunuzu gerçeğe dönüştürmek için pazardaki etkin rolümüz, teknik bilgimiz ve sizlerin destekleriyle çalışmalarımızı sürdürüyor ve vizyonunuzu yansıtıyoruz - *"reflecting your visions"*.



your visions.

Inhalt • Contents • Contenu • Contenido • Contenuti • Contenido • Innehåll • obsah • содержание • İçindekiler

Verzeichnis der Spiegel-Typen Mirror type list Types de rétroviseur Tipos de espelho Tipi di specchio	Tipos de espejo Spegeltyper Typy zpětných zrcadel Перечень типов зеркал Ayna tipi listesi	5
Liste aller MEKRA Artikel im Katalog List of all MEKRA-articles in this catalogue Liste de tous les articles MEKRA dans le catalogue Lista de todas as referências MEKRA neste catálogo Elenco di tutti gli articoli MEKRA in questo catalogo Lista de todas referencias MEKRA en este catálogo Lista på samtliga Mekra-artiklar i denna katalog Obsah všech MEKRA výrobků v tomto katalogu Список всех продуктов фирмы Mekra в каталоге Bu katalogdaki tüm Mekra ürünlerinin listesi		6 - 8
Aussenspiegel - Verwendungsübersicht Rear view mirrors - model item table Références rétroviseur par type de véhicules Retrovisores Exteriores - Quadro de utilização Applicazioni per marche e veicoli Retrovisores exteriores - cuadro de utilización Översättningstabell för utvändiga speglar Zpětné zrcadlo - přehled použití u užitkových vozidel Наружные зеркала - обзор применения в полезных транспортных средствах Dikiz aynası - model tablosu		9 - 11
Homologationsnummernliste List of homologation numbers Liste des numéros d'homologation Lista de números de homologação Lista dei numeri di omologazione	Lista de números de homologación Lista med EG-typgodkännandenummer Seznam homologačních čísel Список контрольных номеров ЕС Onay numera listesi (homologasyon numaraları)	12 - 13
Glasgrößenliste Glass dimension list Liste de dimensions des glaces Lista de dimensões dos vidros Lista delle dimensioni degli specchi	Lista de dimensiones de cristales Lista för reservglas Seznam náhradních skel a jejich velikostí Перечень размера стёкл Cam ebatları listesi	14
Vergleichsliste nach OE - Nummern Cross-reference-table Tableau des références Lista de comparação segundo os numeros originais dos fabricantes Ricerca per codice Lista de comparación según los números originales de los fabricantes (OE) Korsreferens lista Porovnávací tabulka s orig. čísly Сравнительная таблица по оригинальным номерам Çapraz başvuru tablosu		15 - 24
DAF FENDT (AGCO) FORD HINO IRISBUS IVECO-MAGIRUS MAN MERCEDES RENAULT SCANIA VOLVO Volkswagen (VW)		26 - 31 32 33 34 35 36 - 39 40 - 54 55 - 73 74 - 79 80 - 81 82 - 81 92 - 97
Universal • Universal • Universal • Universal • Universal Universal • Universal • Univerzální • Универсально • Üniversal		98 - 111
Allgemeine Verkaufs- und Lieferbedingungen General terms and conditions of sale and delivery Conditions générales de vente et de livraison Termos e condições gerais de venda e entrega Condizioni generali di vendita e consegna	Condiciones generales de venta y entrega (AVL) Leverans & försäljningsvillkor Obecné prodejní a dodací podmínky Общие условия продажи и поставки Genel satış ve teslim koşulları	112 - 113



1008	37
1009	102
1010	102
1012	67
110	93
152 ASKB	32
152 K	98
153 N	99
156 BO	99
156/1 BO	99
156/2 BO	41
156/4 BO	55
156/5 BO	41
156/6 BO	80, 83
196	92
198	92
202	104
224	88
242	98
244	55
246 P	104
248-2	106
249 K	55
250	36, 82
251 K	40
252	83
253	36, 56, 82
254	56
255	82
256	53
257	80
258	57
259	80
260	41
260/1	108
261	83
264	36
265	43
266	43
267	41
268	40
269	59
271	53, 54, 90, 103
273	69
274	91
276	54
277	52
278	52
280	69
281	35
282	58
283	58
284	58
285	57
286	79



287	79
288	79
289	98
300-1	104
348	27, 78
349	70, 93
363	34, 100
364	40
366	68
367	59, 68
368	59
370	84
371	84
373	26, 44
375	62
378	60, 61
380	45
381	45
385	32
386	26, 44
389	47, 101
390	30, 31, 74, 75, 76, 77, 86, 87
392	48, 50
392-1	49
393	48
393-1	49
394	46, 50
394-1	50
396	66
398	68
400	81
460	38
461	38
462	39
463	39
500	100
552	29, 31, 77, 79, 81, 87
552-1	81, 100, 101
558	30, 74, 76, 81, 86
570	28
571	28
572	47
573	47
575	64
577	64
579	61, 65
580	51
589	71, 72, 73, 95, 96, 97
750	100
906	26, 34
922	94
923	94
931	33



Spiegelstangen ● mirror brackets
 bras de fixation ● braço de fixação
 braccio ● soportes ● fäste
 držáky zrcadel ● трубчатые крон-
 штейн зеркала ● айна kollari

152 A	109
156/3 A	109
242 A	108
248 A	110
248-2	106
252 A	108
255 A	109
260 A	109
260/1	108
270 A	111
271 A	106
300 A	109



04.0603.004H	48, 49	11.3900.200H	30, 31, 74, 75, 86, 87	15.3910.871H	76	20.2710.121	53, 90, 91, 103	40.2570.222H	80
08.2240.001.099	88		74, 75	15.3910.872H	77		53	40.2570.422H	80
08.2240.002.099	88	11.3900.201H		15.3911.871H	30, 74, 86	20.2710.132D	53, 54	40.2580.222H	57
08.2415.250	105	11.3910.110H		15.3911.872H	31, 75, 87	20.2710.142D	53, 54	40.2580.422H	57
08.2770.001.000	52	11.3910.111H		15.3920.840H	49	20.2710.200H	53, 54, 90, 91, 103	40.2590.114H	80, 93
08.2810.124	69	11.3910.120H		15.3921.870H	48		54, 69, 91, 103, 106	40.2605.204H	41
08.3200.233H	91, 107	11.3910.121H		15.3922.870H	48	20.2710.620	53, 54, 91, 103, 106	40.2615.204	83
08.3200.250H	107	11.3910.200H	30, 31, 74, 75, 86, 87	15.3931.870H	49	20.2710.630H	53, 54, 91, 103, 106	40.2647.204H	36
08.3700.326H	84		74, 75	15.3932.870H	48		54, 69, 91, 103, 106	40.2655.204	43
08.5751.324E	31, 75, 77, 87	11.3910.201H		15.3941.670H	50	20.2780.630	52	40.2660.404H	43
08.5751.424E	30, 74, 76, 86	11.3920.300H		15.3941.870H	50	20.2780.631	52	40.2665.204H	43
08.5890.100	71, 95	11.3921.110H		15.3942.650H	50	20.2800.550	69	40.2685.204H	40, 41
08.5891.110	71, 95	11.3921.120H		15.3942.850H	50	20.2800.650	69	40.2695.204H	59
08.5891.111	71, 95	11.3921.400		15.3946.670H	46	20.2810.110H	35	40.2875.404H	79
08.5891.120	71, 95	11.3931.110H		15.3946.870H	46	20.2840.110	58	40.2890.222H	32, 98
08.5891.130	71, 95	11.3931.120H		15.3951.114	69	20.3750.710	62	40.2890.422H	32, 98
08.5891.140	71, 95	11.5520.401		15.3951.174	69	20.3750.720	62	40.3005.222	104
08.5891.141	71, 95	11.5700.100H		15.3961.174H	66	20.3780.700H	61	40.3200.422H	42
09.2000.301H	32, 34, 42, 43, 106	11.5710.110H		15.4001.110H	81	20.3790.500	61	40.3300.218H	34
		11.5800.100H		15.4001.740H	81	20.3900.510	30, 74, 76, 86	40.3300.418	34
09.2070.101H	36, 40, 41, 42, 55, 56, 57, 82, 83, 98, 106	11.9060.100H	26, 34	15.4001.840H	81	20.3900.520H	31, 75, 77, 87	40.3302.418H	34
		13.5800.100H		15.4002.110H	81	20.4600.200	38	40.3485.403E	27, 78
		13.5890.120	71, 73, 95, 97	15.4002.114H	81	20.4601.100H	38	40.3605.203H	85
09.2560.200	53	13.5890.220	71, 73, 95, 97	15.4601.164H	38	20.4610.100H	38	40.3605.204	61, 85
09.2770.210	52	14.2240.001.099	88	15.4602.164H	38	20.4610.200	38	40.3605.403H	61, 85
09.2770.220	52	14.2240.002.099	88	15.4611.164H	38	20.4611.100H	38	40.3640.222H	40, 42
09.2770.230	52	15.1962.100H	92	15.4612.164H	38	20.4620.100H	39	40.3640.322H	40
09.3200.210	106, 107	15.1962.151H	92	15.4621.164H	39	20.4621.100H	39	40.3640.422H	40, 42
09.3200.220	91, 106, 107	15.1962.152H	92	15.4621.870H	39	20.5520.100	100	40.3650.404H	46
09.3200.310H	106, 107	15.1964.100H	92	15.4622.164H	39	20.5520.250	79	40.3655.204	46
09.3200.320H	106, 107	15.1964.152H	92	15.4630.870H	39	20.5520.260	77	40.3665.118F	68
09.3200.410H	32, 34, 42, 107	15.2240.840H	88	15.4631.164H	39	20.5520.270	31, 77, 87	40.3670.404H	59, 68
		15.2242.870H	88	15.4631.870H	39	20.5521.100	29	40.3675.204H	59, 68
09.3200.420H	42, 107	15.2561.600	53	15.4632.164H	39	20.5580.110H	30, 74, 76, 86	40.3680.222H	59
09.3300.421	106, 107	15.2561.640	53	15.5701.840H	39	20.5580.120H	31, 75, 77, 87	40.3680.422H	59
09.3400.420	32, 34, 42, 107	15.2711.114	53, 90	15.5711.870H	28	20.5580.130H	30, 74, 76, 86	40.3965.202H	47
		15.2711.214H	70, 93	15.5711.870H	28	20.5580.140F	30, 31, 75, 77, 87	40.4485.114	99
09.3920.110H	48, 49	15.2712.114	53, 90	15.5750.840H	64		30, 31, 75, 77, 87	40.5725.112F	47
09.5700.001.099	28	15.2771.840	52	15.5770.870H	64	20.5700.410H	28	40.5725.212H	47
09.5700.002.099	28	15.2771.870	52	15.5791.470H	61, 65	20.5700.420H	28	40.5725.412H	47
09.5750.001.099	64	15.2780.840	52	15.5801.840H	51	20.5800.410H	51	40.5735.203H	47
09.5750.220.099	64	15.2780.870	52	15.5811.871H	51	20.5800.420H	51	40.5735.403H	47
10.2577.400	80	15.2800.470H	69	15.5811.872H	51	20.5800.610H	51	51.1009.001.001	102
10.2820.410E	58	15.2800.480H	69	15.5891.611H	71, 95	20.5800.620H	51	51.1009.009.001	102
10.3670.410H	59, 68	15.2810.470H	35	15.5891.612H	71, 95	20.5800.710H	51	51.1009.025.001	102
10.3681.400	59	15.2810.480H	35	15.5891.741H	71, 95	20.5800.720H	51	51.1009.033.001	102
10.3710.400	57	15.2822.860H	58	15.5891.742H	71, 95	20.5800.750H	51	51.1009.041.001	102
10.3800.310	47	15.2860.880H	79	15.9060.870H	26, 34	21.1560.100	80	51.1009.049.099	102
10.6111.100	40	15.3480.840H	27, 78	15.9220.110H	94	39.1720.210H	57	51.1009.050.099	102
10.6121.100	36, 40, 42, 82	15.3491.071H	70, 93	15.9220.220H	94	39.1720.410H	57	51.1009.170.001	102
10.6121.140	36, 56, 68, 82	15.3491.072H	70, 93	15.9221.110H	94	39.1900.210	27, 33, 89	51.1100.401H	93
10.6121.150	42	15.3491.371H	70, 93	15.9221.220H	94	39.1900.410H	27, 33, 89	51.1511.119	98
10.6121.160	27, 33, 89	15.3491.372H	70, 93	19.1008.041.099	37	39.2050.110	58	51.1511.219H	98
10.6211.100	40	15.3492.391F	70, 93	19.1008.311.099	37	39.2088.504	58	51.1520.211H	99
10.6211.140	56	15.3492.392F	70, 93	19.1012.000.099	67	39.3120.210H	40	51.1520.212H	99
10.6221.100	32, 40, 46, 98	15.3702.170H	84	19.1012.001.099	67	39.3188.504	58	51.1520.218H	98
10.6221.140	56	15.3702.470H	84, 91	19.1012.002.099	67	39.3730.210H	27, 33, 89	51.1522.211H	99
10.6321.100	36, 41, 43, 58	15.3702.770F	91	19.1012.003.099	67	39.3730.410H	27, 33, 89	51.1524.119H	32
10.6321.160	27, 33, 89	15.3712.110H	84	19.5750.011.099	64	39.4170.210H	58	51.1531.111H	99
10.6421.100	34	15.3712.410H	84	19.5770.311.099	64	39.4170.410H	58	51.1531.114H	99
10.6421.140	57, 83	15.3712.870H	84	19.5890.011.099	73, 97	40.1009.001.000	102	51.1531.115H	99
11.1523.010	109	15.3731.070H	44	19.5890.012.099	73, 97	40.1009.002.000	102	51.1531.118H	99
11.1523.212	36, 109	15.3731.074H	44	19.5890.321.099	73, 97	40.1009.003.099	102	51.2440.117H	55
11.1523.310	99	15.3731.470H	26, 53, 54, 90, 103	19.5890.322.099	73, 97	40.1009.004.099	102	51.2440.217H	55
11.1560.200	80		103	19.5890.411.099	73, 97	40.1510.122H	98	51.2491.121H	55
11.2440.120H	55	15.3750.840H	62	19.5890.412.099	73, 97	40.1524.115H	98, 99	51.2491.122H	55
11.2440.130H	55	15.3752.470H	62, 68	19.5890.721.099	73, 97	40.1525.108	99	51.2493.121H	55
11.2570.100	80	15.3771.174H	60, 62	19.5890.722.099	73, 97	40.1525.114H	99	51.2493.127H	55
11.2800.011	69	15.3774.410H	60, 62	20.1560.116H	80	40.1561.105H	80, 83	51.2493.131H	55
11.2800.012	69	15.3780.840H	60	20.1560.122H	80	40.1565.104F	41	51.2493.137H	55
11.2810.200H	35	15.3784.470H	60	20.2240.001.099	88	40.2460.214H	104	51.2500.127H	36, 82
11.2840.230H	58	15.3791.470H	61, 63, 65	20.2240.002.099	88	40.2500.222H	36, 42, 82	51.2500.147H	36, 82
11.2841.230H	58	15.3794.410H	61, 63, 65	20.2480.210H	106	40.2500.422H	36, 42, 82	51.2510.127H	40
11.3001.100	104, 109	15.3801.640H	45	20.2480.211	68, 106	40.2510.222H	40	51.2510.137H	40
11.3610.310	58	15.3801.840H	45	20.2480.212	68	40.2510.322H	40	51.2510.147H	40
11.3730.210H	26, 53, 54, 90, 100, 103	15.3802.640	100	20.2480.216H	53, 90, 103, 106	40.2510.422H	40	51.2520.127H	83
		15.3802.740F	100		90, 103, 106	40.2520.222H	83	51.2520.147H	83
11.3730.310H	44	15.3802.840H	34, 100	20.2480.217H	53	40.2520.422H	83	51.2530.120H	36, 56, 82
11.3800.300H	45	15.3811.670H	45	20.2480.221	53	40.2530.222H	36, 56, 82	51.2530.140H	36, 56, 82
11.3810.300H	45	15.3811.870H	45	20.2480.222	53	40.2530.422H	36, 56, 82	51.2540.120H	56
11.3860.300H	44	15.3812.410H	44	20.2480.223	106	40.2540.222H	56	51.2540.130H	56
11.3860.500H	26	15.3861.114H	26	20.2600.111H	108	40.2540.422H	56	51.2540.140H	56
11.3860.700	47	15.3862.174H	26	20.2600.112H	108	40.2545.122F	56	51.2550.127H	82
11.3900.100H	76, 77	15.3900.840H	30, 31, 74, 75, 76, 77, 86, 87	20.2710.111H	53, 90, 91, 103	40.2550.222H	82	51.2576.127H	80
11.3900.101H	76, 77							51.2576.147H	80

MEKRA	MEKRA	MEKRA	MEKRA	MEKRA	MEKRA	MEKRA	MEKRA		
51.2580.120H	57	51.3924.223D	49	51.9221.110H	94	56.5730.120H	47	59.1008.017.099	37
51.2580.140H	57	51.3924.224H	49	51.9221.220H	94	56.5730.127H	47	59.1008.018.099	37
51.2580.160H	57	51.4601.120H	38	51.9230.110H	94	56.5730.140H	47	59.2240.001.099	88
51.2590.117H	80	51.4601.130H	38	51.9230.220H	94	56.9065.110	26, 34	59.2240.002.099	88
51.2820.120H	58	51.4601.230	38	51.9231.110H	94	58.2423.320H	108	59.2242.300H	88
51.2820.140H	58	51.4612.120H	38	51.9231.220H	94	58.2481.011H	110	59.2242.301.099	88
51.2822.160H	58	51.4612.130H	38	51.9310.110H	33	58.2481.012	110	59.2242.400H	88
51.2860.001.099	79	51.4612.230	38	51.9310.120H	33	58.2484.612	110	59.2242.401.099	88
51.2860.002.099	79	51.5524.930H	31, 77, 79, 81, 87, 101	51.9310.410H	33	58.2485.011H	110	59.2640.110H	36
51.2860.112H	79			51.9310.420H	33	58.2485.012H	110	59.2652.110H	43
51.2860.212H	79	51.5524.950F	101	53.1960.161H	92	58.2520.011H	108	59.2690.127H	59
51.2890.117H	98	51.5720.120H	47	53.1961.113H	47	58.2520.012H	108	59.2693.127H	59
51.2890.147H	98	51.5720.127H	47	53.1961.161H	47	58.2550.110	109	59.2710.401H	90, 103
51.3000.127H	42	51.5720.140H	47	53.1962.123H	47	58.2600.010H	109	59.2710.402H	90, 103
51.3100.147H	42	51.5721.050	47	53.1981.127H	47	58.2601.010	109	59.2710.406	103
51.3200.137H	42	51.5721.160H	47	53.1981.177H	47	58.2652.010	43	59.2710.411	103
51.3200.146H	42	51.5722.050H	47	53.1982.127H	47	58.2704.044	111	59.2710.412	103
51.3200.147H	42	51.5722.160H	47	53.1982.177H	47	58.2704.048	111	59.2712.111	53
51.3300.147H	34	51.5750.001.099	64	55.1008.001.099	37	58.2704.051H	111	59.2712.114	53
51.3310.127H	34	51.5750.002.099	64	55.1008.002.099	37	58.2704.070H	111	59.2718.112	53, 54
51.3310.147H	34	51.5750.003.099	64	55.2020.177H	104	58.2704.086H	111	59.2730.401	69
51.3400.147H	42	51.5750.004.099	64	55.2021.177	104	58.2704.088	111	59.2730.402	69
51.3410.127H	42	51.5770.001.099	64	55.2461.113	104	58.2704.093H	111	59.2743.322	91
51.3410.140H	42	51.5891.111.199	72, 96	55.2561.010	53	58.2705.001	111	59.2743.323	91
51.3410.147H	42	51.5891.111H	71, 95	55.2561.110	53	58.2705.002	111	59.2743.332	91
51.3412.120H	42	51.5891.112.199	72, 96	55.3000.117H	104	58.2705.003	111	59.2743.333	91
51.3490.110H	70	51.5891.113.199	72, 96	55.0500.000H	100	58.2705.007P	111	59.2762.101	54
51.3490.112H	70	51.5891.113H	71, 95	56.0750.000H	100	58.2705.008	111	59.2762.201	54
51.3490.120H	70	51.5891.211.199	72, 96	56.1008.001.099	37	58.2705.009	111	59.2762.322	54
51.3490.122H	70	51.5891.211H	71, 95	56.1008.002.099	37	58.3631.322	34	59.2762.422	54
51.3495.110H	93	51.5891.212.199	72, 96	56.1523.114H	99	58.3631.422	34	59.2770.110	52
51.3495.112H	93	51.5891.213.199	72, 96	56.1523.117H	99	58.3701.130H	84	59.2770.210	52
51.3495.120H	93	51.5891.213H	71, 95	56.1560.117H	41	58.3701.140H	84	59.2771.210	52
51.3495.122H	93	51.5891.311.199	72, 96	56.1561.110H	80, 83	58.3752.100	62	59.2780.110	52
51.3635.201	100	51.5891.311H	71, 95	56.2240.001.099	88	58.3752.200	62	59.2780.120	52
51.3635.204	100	51.5891.312.199	72, 96	56.2240.140H	88	58.3752.300E	62	59.2781.120	52
51.3635.205	100	51.5891.313.199	72, 96	56.2240.141.099	88	58.3752.400E	62	59.2810.111H	35
51.3635.206	34, 100	51.5891.313H	71, 95	56.2241.140H	88	58.3781.100H	61	59.2810.113H	35
51.3636.201	100	51.5891.411.199	72, 96	56.2241.141.099	88	58.3781.200H	61	59.2810.211H	35
51.3636.204	100	51.5891.411H	71, 95	56.2441.117H	55	58.3783.200H	61	59.2810.213H	35
51.3636.205	100	51.5891.412.199	72, 96	56.2441.118H	41	58.3783.300H	61	59.2840.120H	58
51.3636.206	34, 100	51.5891.413.199	72, 96	56.2600.127H	41	58.3900.133H	30, 74, 86	59.2880.130H	79
51.3640.127H	40	51.5891.413H	71, 95	56.2600.137H	41	58.3900.143H	30, 74, 76, 86	59.3491.110H	70
51.3640.137H	40	51.5892.111.199	72, 96	56.2600.147H	41	58.3900.233H	31, 75, 87	59.3491.120H	70
51.3640.147H	40	51.5892.111H	71, 95	56.2610.127H	83	58.3900.243H	31, 75, 77, 87	59.3492.110H	70
51.3660.147	68	51.5892.112.199	72, 96	56.2610.147H	83	58.3900.333H	30, 74, 86	59.3492.120H	70
51.3660.167	68	51.5892.113.199	72, 96	56.2640.127H	36	58.3900.343H	30, 74, 76, 86	59.3601.128H	85
51.3680.147H	59	51.5892.113H	71, 95	56.2640.147	36	58.3900.433H	31, 75, 87	59.3601.178H	85
51.3680.167H	59	51.5892.211.199	72, 96	56.2650.121H	43	58.3900.443H	31, 75, 87	59.3601.188H	85
51.3712.241E	84	51.5892.211H	71, 95	56.2660.127H	43	58.3922.021H	50	59.3602.128H	61, 85
51.3731.326	53, 54, 90, 103	51.5892.212.199	72, 96	56.2660.147H	43	58.3922.221D	50	59.3602.189	85
		51.5892.213.199	72, 96	56.2662.120D	43	58.3922.321H	50	59.3604.178H	61, 85
51.3732.326H	53, 54, 90, 103	51.5892.213H	71, 95	56.2670.127H	41	58.5524.020	81	59.3631.322	34
		51.5892.311.199	72, 96	56.2670.147H	41	58.5524.021	81	59.3631.422	34
51.3735.121H	44	51.5892.311H	71, 95	56.2680.121H	40	58.5701.100H	28	59.3652.147H	46
51.3735.124H	44	51.5892.312.199	72, 96	56.2830.120H	58	58.5701.200H	28	59.3652.148H	46
51.3735.126H	44	51.5892.313.199	72, 96	56.2830.140H	58	58.5701.310H	28	59.3652.167H	46
51.3736.121H	44	51.5892.313H	71, 95	56.2850.120H	57	58.5701.410H	28	59.3652.168H	46
51.3736.124H	44	51.5892.411.199	72, 96	56.2850.140H	57	58.5713.110H	28	59.3702.231H	84
51.3736.126H	44	51.5892.411H	71, 95	56.2870.130H	79	58.5713.120H	28	59.3702.431H	84
51.3801.128D	45	51.5892.412.199	72, 96	56.2870.140H	79	58.5713.210H	28	59.3712.241H	84
51.3801.148H	45	51.5892.413.199	72, 96	56.3491.110H	70, 93	58.5713.220H	28	59.3792.127H	61, 63, 65
51.3801.168H	45	51.5892.413H	71, 95	56.3492.110H	70, 93	58.5714.110H	28	59.3793.127H	61, 63, 65
51.3802.128D	45	51.5893.111.199	72, 96	56.3670.147H	59, 68	58.5714.120H	28	59.3891.140H	101
51.3802.148H	45	51.5893.111H	71, 95	56.3811.168H	45	58.5714.210H	28	59.3891.150H	101
51.3802.168H	45	51.5893.112.199	72, 96	56.3812.128H	45	58.5714.220H	28	59.3894.241H	47
51.3850.127H	32	51.5893.113.199	72, 96	56.3812.148H	45	58.5750.005.099	64	59.3894.242H	47
51.3850.147H	32	51.5893.113H	71, 95	56.3812.168H	45	58.5750.006.099	64	59.3900.123H	76
51.3850.167H	32	51.5893.211.199	72, 96	56.3860.112H	44	58.5750.012.099	64	59.3900.132H	30, 74, 86
51.3894.140	47, 101	51.5893.211H	71, 95	56.3860.114H	44	58.5750.013.099	64	59.3900.133H	30, 74, 86
51.3894.160H	101	51.5893.212.199	72, 96	56.3861.116H	44	58.5750.015.099	64	59.3900.142H	30, 74, 86
51.3921.222H	48	51.5893.213.199	72, 96	56.3862.116H	44	58.5752.100H	64	59.3900.143H	30, 74, 86
51.3921.223H	49	51.5893.213H	71, 95	56.3865.232	44	58.5752.200H	64	59.3900.223H	77
51.3921.224H	49	51.5893.311.199	72, 96	56.3931.222H	48	58.5752.300H	64	59.3900.232H	31, 75, 87
51.3922.222H	48	51.5893.311H	71, 95	56.3931.323H	49	58.5752.400E	64	59.3900.233H	31, 75, 87
51.3922.223H	49	51.5893.312.199	72, 96	56.3931.343H	49	58.5800.101H	51	59.3900.242H	31, 75, 87
51.3922.224H	49	51.5893.313.199	72, 96	56.3932.222H	48	58.5800.102H	51	59.3900.243H	31, 75, 87
51.3922.232H	48	51.5893.313H	71, 95	56.3932.323H	49	58.5800.201H	51	59.3901.123H	76
51.3922.233H	49	51.5893.411.199	72, 96	56.3932.343H	49	58.5800.202H	51	59.3901.132H	74
51.3923.222D	48	51.5893.411H	71, 95	56.3960.148H	66	59.1008.005.099	37	59.3901.133H	74
51.3923.223D	49	51.5893.412.199	72, 96	56.3962.127H	66	59.1008.006.099	37	59.3901.142H	74
51.3923.224H	49	51.5893.413.199	72, 96	56.4620.247H	39	59.1008.007.099	37	59.3901.143H	74
51.3923.232D	48	51.9220.110H	71, 95	56.4620.267H	39	59.1008.008.099	37	59.3901.223H	77
51.3923.233H	49	51.9220.220H	94	56.4621.220H	39	59.1008.011.099	37	59.3901.232H	75
51.3924.222H	48		94	56.4622.200	39	59.1008.012.099	37	59.3901.233H	75



59.3901.242H	75	59.5520.030H	81	59.5525.136H	29	61.2530.110H	36, 56, 57, 82	61.3783.167H	60
59.3901.243H	75	59.5520.040H	81	59.5525.235H	29	61.2708.842H	111	61.3860.100	26, 34
59.3941.212H	50	59.5520.050H	81	59.5525.236H	29	61.2800.401H	69	61.3860.214H	26
59.3941.222H	50	59.5520.130H	29	59.5525.331H	29	61.2800.402H	69	61.3865.124H	26
59.3941.413H	50	59.5520.140H	29	59.5525.332H	29	61.3480.149H	27, 78	61.3865.224	26
59.3941.423H	50	59.5520.230H	29	59.5580.147H	29	61.3481.149H	27, 78	61.3865.234	26
59.3941.515H	46	59.5520.240H	29	59.5580.247H	30, 74, 76, 86	61.3482.149H	27, 78	61.3890.111H	101
59.3941.544H	46	59.5520.250H	100	59.5581.100H	30, 74, 76, 86	61.3700.231H	84	61.3890.113H	101
59.3961.310H	66	59.5520.530H	100	59.5790.110H	61, 65	61.3700.241H	84	61.3900.100H	30, 31, 74, 75, 86, 87
59.3962.210H	66	59.5524.032H	81	59.5800.101H	51	61.3710.231H	84	61.3900.110H	30, 74, 76, 86
59.3964.210H	66	59.5524.034H	81	59.5800.102H	51	61.3710.241H	84	61.3900.120H	31, 75, 77, 87
59.3964.310H	66	59.5524.530H	101	59.5800.121H	51	61.3730.324H	26	61.3910.110H	76
59.3965.210H	66	59.5524.638H	87	59.5800.122H	51	61.3730.326H	26	61.3910.120H	77
59.3965.310H	66	59.5524.640.099	77	59.5800.201H	51	61.3752.147H	62, 68	61.3911.110H	30, 74, 86
59.3980.011H	68	59.5524.648.099	31, 77	59.5800.202H	51	61.3770.167H	62, 68	61.3911.120H	31, 75, 87
59.3980.012	68	59.5524.649.099	77	59.5800.203H	51	61.3770.147H	60, 62	61.5700.210H	28
59.3980.021H	68	59.5524.730.099	79	59.5800.221H	51	61.3772.147H	60, 62	61.5700.310.099	28
59.3980.022H	68	59.5524.748.099	79	59.5800.222H	51	61.3773.147H	60, 62	61.5710.210H	28
59.4630.247H	39	59.5525.131H	29	59.5800.302H	51	61.3780.100H	60, 62, 66, 68	61.5710.310.099	28
59.4630.267H	39	59.5525.132H	29	59.5800.322H	51	61.3780.147H	60	61.5750.100H	64
59.4631.200H	39	59.5525.133H	29	59.5800.402H	51	61.3782.147H	60	61.9065.114H	26, 34
59.4631.300H	39	59.5525.134H	29	59.5800.422H	51	61.3782.167H	60		
59.4631.320H	39	59.5525.135H	29	61.1561.100H	80, 83	61.3783.147H	60		

Wölbungsradien • radius of dishing • rayons de convexité • Radio de convexidade • raggio convesso
radio de convexidad • böjningsradie • poloměr zakřivení • радиус выпуклости • büküm yarıçapı

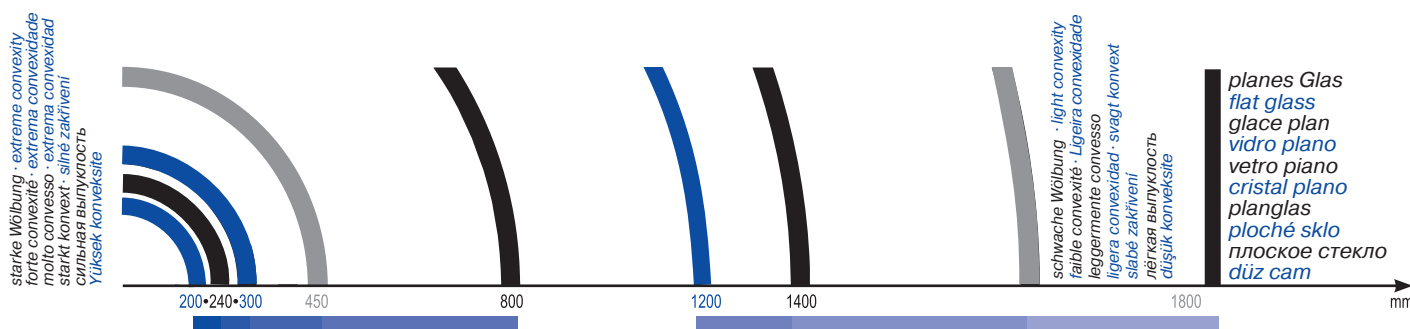

Totwinkelspiegel
 dead angle mirror
 miroir angle mort
 espelho para ponto cego
 specchio per angolo morto
 espejo de ángulo muerto
 dōda vinkeln spiegel
 zrcadlo mrtvý úhel
 зеркало для „смертельного гла“
 ölü nokta aynası



Class IV
 Weitwinkelspiegel
 wide angle mirror
 rétroviseur grand angle
 espelho auxiliar
 coppa grandangolo
 espejo de gran ángulo
 vidvinkelspegel
 zrcadlo širokouhlé
 широкоугольное зеркало
 geniş görüş aynası



Class II
 Hauptspiegel
 main mirror
 rétroviseur principal
 espelho principal
 retrovisore principale
 espejo principal
 huvudspegel
 zrcadlo hlavní
 главное зеркало
 ana ayna

Class III
 PKW-Spiegel
 car mirror
 rétro p. voitures particulières
 espelho para carro de passeio
 specchio vettura
 espejo p. coches turismos
 spegel för personbil
 zrcadlo pro osobní automobil
 Зеркало для легкового автомобиля
 binek oto aynası

Class VI
 Frontspiegel
 front-under-mirror
 miroir frontal
 espelho frontal
 guardaruota anteriore
 retrovisor para parte frontal del vehiculo
 frontspiegel
 čelní zrcadlo
 Фронтальное зеркало
 ön tampon aynası



Class V
 Rampenspiegel
 roof mirror
 miroir d'accostage
 espelho de Rampa
 specchio guardaruota
 espejo de rampa
 närsiktsspegel
 zrcadlo rampové
 зеркало для рампы
 kapı üstü aynası



Class I
 Innenspiegel
 inside mirror
 miroir interieur
 espelho interior
 specchio interno
 espejo interior
 innerspiegel
 vnitřní zrcadlo
 внутреннее зеркало
 iç ayna

radius
 radius
 rayon
 raio
 raggio
 radio
 radiu
 radius
 Радиус
 Yarıçap
 mm



gemäß alter Verordnung 71/127/EG
 according to former directive 71/127/EEC
 suivant directive ancienne 71/127/ECE
 em acordo com a diretriz orientadora 71/127/EEC
 secondo direttiva CEE 71/127
 de acuerdo con la directiva 71/127/EEC
 enligt direktiv 71/127/EEC
 die nařízení 71/127/ES
 согласно предписаниям 71/127/ЕЭС
 eski talimat 71/127 EEC'ye göre

31.03.2009

gemäß Verordnung 2003/97/EG*, gültig seit 01/2007
 bzw. 2007/38/EC**, gültig ab 04/2009
 according to directive 2003/97/EC*, valid from 01/2007
 or 2007/38/EC**, valid from 04/2009
 suivant directive 2003/97/EC*, à partir de 01/2007
 ou 2007/38/EC**, à partir de 04/2009

em acordo com a diretriz orientadora 2003/97/EEC* (01/2007)
 2007/38/EC** (04/2009)

secondo la direttiva CEE 2003/97*, valida dal 01/2007
 CEE 2007/38**, valida dal 04/2009.

de acuerdo con la directiva 2003/97/EEC*,
 en vigor a partir del 01/2007
 2007/38/EEC**, en vigor a partir del 04/2009

enligt direktiv 2003/97/EEC* gällande fr.o.m. år 01/2007
 2007/38/EEC** gällande fr.o.m. år 04/2009

die nařízení 2003/97/ES*, platné od 01/2007
 2007/38/ES**, platné od 04/2009

согласно настоящим предписаниям 2003/97/ЕЭС*,
 действительным с 2007 г. или
 2007/38/ЕЭС** действительным с 2009 г.

2003/97/EC* talimatına göre, 01/2007'den itibaren geçerli yada
 2007/38/EC** 04/2009'dan itibaren geçerli

radius
 radius
 rayon
 raio
 raggio
 radio
 radiu
 radius
 Радиус
 Yarıçap
 mm



DAF

Modell • model modèle modello modelo модель	Typ • type tipo • тип tip	Klasse • class • clase • classe • class • Класс • sınıf	IV	V	VI	
FA	1700 - 3300	1987-	39.3730.210H 39.3730.410H	39.1900.210 39.1900.410H	—	
—	75	0992-0200	39.3730.210H 39.3730.410H	0.373 <i>alternativ</i>	0.386 0.381-1 <i>alternativ</i>	0.552-1 0.389
	85			Original	Original	
	95					
CF	65	- 04/2006	0.373	0.386 0.381-1 0.906	0.265 <i>alternativ</i>	
	75					
	85					
LF	45	- 05/2006	0.470 / 0.348	0.348		
	55					
XF	95	- 04/2006	0.373	0.386 0.381-1 0.906		
	105					
XC		01/2006-	0.570	0.571	0.552	
CF		05/2006-			0.558	
LF				0.390	59.5624.6384	

FORD

Modell • model modèle modello modelo модель	Typ • type tipo • тип tip	Klasse • class • clase • classe • class • Класс • sınıf	IV	V	VI
Transit	Bus / Van	1994 - 2000	0.555		—
		2001 -	0.931		
Cargo		1984 -	39.3730.210H 39.3730.410H	39.1900.210H 39.1900.410H	—

HINO

Modell • model modèle modello modelo модель	Typ • type tipo • тип tip	Klasse • class • clase • classe • class • Класс • sınıf	IV	V	VI
700		- 03/2007	0.330 / 0.331		—
300		2007 -			
500		2008 -	0.363	0.906	0.552-1 0.389
700		04/2007 -			

IVECO

Modell • model modèle modello modelo модель	Typ • type tipo • тип tip	Klasse • class • clase • classe • class • Класс • sınıf	IV	V	VI		
ANW / NW		01/74 -	0.250				
AHW / HW				0.264	0.264		
Turbo Star 190		07/84 - 12/93	0.450				
MK	6 - 13 to	12/88 - 08/94	0.253				
Euro-cargo	60 E 10	09/00 - 03/06	0.475	0.264	0.463	0.552-1 0.389	
	75 E 12			---			
	75 E 13			0.460 / 0.461 / 0.462 / 0.264	0.463		
	75 E 14			0.460 / 0.345 / 0.461 / 0.345 / 0.462 / 0.264			
	75 E 15 (tector)			0.345 <i>alternativ</i>	0.264		
	80 E 15				---		
	80 E 18				0.264		
	85 E 18			0.460 / 0.461 / 0.462	0.264		0.463
	120 EL 21						
	120 E 28 tector						
	190 E 38			0.345 <i>alternativ</i>	0.264		
260 - 36							

IVECO

Modell • model modèle modello modelo модель	Typ • type tipo • тип tip	Klasse • class • clase • classe • class • Класс • sınıf	IV	V	VI
Eurotech					
Eurostar					
Euro-Trakker		06/93 - 03/06	0.460	0.461	0.462
Cursor				0.463	0.552-1 0.389
Stralis		2002 - 03/06			
Eurocargo					
Trakker		04/06 -		1008	
Tector					
Stralis					
Turbo Daily		1990 - 05/96	0.901	---	---
Bus	EA Gera Travel Skate HD		0.271		

MAN

Modell • model modèle modello modelo модель	Typ • type tipo • тип tip	Klasse • class • clase • classe • class • Класс • sınıf	IV	V	VI			
F8 / F9		- 07/1988	0.364	0.268	0.156/5 BO 0.156/2 BO			
G 90	(MAN-VW)	10/75 - 07/88	0.251 K		0.265			
M 90	12.192	08/88 - 09/94 - 03/2000	0.364	0.265				
	12.232		0.320 / 0.341					
	14.232							
	14.272		0.320					
	15.264		0.320 / 0.341					
	17.192							
	17.222							
	17.232		0.320					
F 90	18.222	08/88 - 09/94 - 03/2000	0.364	0.260 0.266	0.156/5 BO			
	18.224					0.320		
	18.232					0.341		
	18.422					0.320		
	19.272					0.320		
	19.322					0.320 / 0.341		
	19.362					0.320		
	19.372							
	19.422							
	19.462					0.320 / 0.341		
	19.502							
	23.362						0.364	
	24.232					0.341	0.265	0.552-1 0.389
	24.362							
	24.372							
25.362								
25.422								
26.322								
26.372	0.320 / 0.341							
26.402								
27.402	0.320							
34.372								
35.322	0.341 / 0.320							
35.372								
L 2000	8.153	09/94 -	0.341	0.266	0.365			
	8.163					0.320 / 0.341		
	8.224					0.341		
	9.153					0.320		
	9.163					0.341		
	10.153					0.320		
	10.163					0.320 / 0.341		
	10.223					0.341		
	10.224					0.320		
	LE 140 C							
	LE 180 C							
	LE 180 L					0.341 / 0.320		
	LE 220 C							
	LE 220 E					0.341		
LE 8 180	0.373	0.386	0.260 / 0.266	—				
	0.341							

zpětné zrcadlo - přehled použití u užitkových vozidel **dikiz aynasi (model tablosu)**
 Lista de comparação segundo os numeros originais dos fabricantes **retrovisores exteriores - cuadro de utilizacion / vehiculos industriales**
Rear view mirror item table trucks / commercial vehicles
applicazioni per marche e veicoli **наружные зеркала - обзор применения в полезных транспортных средствах**
AUSSENSPIEGEL-VERWENDUNGSÜBERSICHT NKW
 References retroviseurs par type de vehicules **Oversättningstabell för utvändiga speglar**

MAN		Modell • model modèle modello modelo модель	Typ • type tipo • тип tip	Klasse • class clase • classe • class • Класс • sınıf	II	IV	V	VI			
M 2000	12.163	0997			0.341	0.266	0.365				
	13.604										
	14.224										
	14.284										
	15.264										
	18.224										
	18.264										
	18.284										
	LE 280 B										
F 2000	19.343	0994			0.373	0.386	0.552-1 0.389				
	19.364										
	19.403										
	19.414										
	19.463										
	19.464										
	19.603										
	19.932										
	23.414										
	24.403										
	24.463										
	25.322										
	26.314										
	26.364										
	26.372										
	26.403										
	26.414										
	26.463										
	26.464										
	27.403										
	27.464										
	28.372										
	33.364										
	33.414										
33.464											
35.403											
35.463											
40.414											
41.372											
41.414											
FE 410 A											
FE 460 A											
ME 280 B											
TGA		03/2000			0.392	0.394 0.394-1	0.393 0.393-1	0.389			
TGL „Premium Version“		2005									
TGM		04/2006									
TGX TGS		08/2007			0.580						
TGL		06/2005			0.572	0.573					
TGM											
Busse buses MAN	A 01						0.271	—			
	A 03										
	A 04										
	A 13										
	A 20										
	A 32										
	RH 413 / 463 Lion's Top Coach / Lion's Coach										
	Euroliner								09/2001		
	Euroliner								2003		
	Euroliner								2002	0.276	0.271
	22.330										
	362 FRH										
	NG 272										
NL 202											
Busse buses Neoplan	Cityliner	1974					39.3655.320H				
	Spaceliner										
	Skyliner										
	Jetliner										
	Metroliner										

MAN		Modell • model modèle modello modelo модель	Typ • type tipo • тип tip	Klasse • class clase • classe • class • Класс • sınıf	II	IV	V	VI
Busse buses MANAS	A 72 Citybus	091999			0.373	0.341	0.271	—
	A 74 Citybus							
	A 75 Citybus							
	R 06 Coach							
	R 07 Coach							
Busse buses Neoman	Lion's City	2007			0.278	0.277	0.278	—
	Lion's Regio							
	Lion's Star							
	NAG							

MERCEDES		Modell • model modèle modello modelo модель	Typ • type tipo • тип tip	Klasse • class clase • classe • class • Класс • sınıf	II	IV	V	VI
Unimog	U 140				0.258 *	0.364	—	—
	U 1250							
	U 1600							
	U 1850							
	U 2400							
	U 2450							
T1 / T2	207 D	0981-0295			0.249 L	—	—	—
	210 D							
	308 D							
	508 D							
	410 D							
	608 D							
	609 D							
	709 D							
	711 D							
	811 D							
	814 D							
	LK / MK / SK							
817								
917								
1017								
1113								
1114								
1117								
1120								
1213								
1218								
1317								
1324								
1422								
1517								
1520								
1524								
1622								
1628								
1633								
1635								
1644								
1717								
2222								
2235								
2517								
2521								
2524								
2527								
2644								
SK I	NG 90/I	0988-1290			0.282	0.283	0.284	
SK II	NG 90/II	0191-0956			0.368	0.367	0.269	
Actros I	SKL	091999			0.378	0.377-1	0.377	0.379
		0607-0508						0.579
Econic		031999			0.378-1	0.377-1	0.360	0.360-1

MERCEDES

Modell • model modèle modelo modelo модель	Typ • type tipo • тип tip	Klasse • class clase • classe • class • Класс • sınıf	II	IV	V	VI
Atego I	LKN	01/98-09/04	0.375	0.377 0.377-1	0.379 0.379-1	0.396
Axor	LKN	09/01-09/04				
Atego II Axor II	LKN	10/04-06/07 09/2007-	0.575	0.577	0.579	
Actros	MP3	06/08-	1012		—	
Sprinter	MP3	01/95-09/05	0.349	—		
Sprinter II	NCV3	10/2005-	0.589	—		
Busse buses	O 303		0.253	0.285		
	O 304		0.258			
	O 340		0.253			
	O 350 Coach		0.270			
	O 350 Turismo		0.272			
	O 371		0.258			
	O 402				—	
	O 405 N		0.253			—
	O 404			0.285 0.367		
	O 404 Coach		0.270			
	O 407		0.258			
	O 408				—	
	O 614 D		0.254	0.253		
	O 345 Connecto H / C-U	1999-	0.398 / 0.273			
Travego	09/1997-					
Tourino	10/2003-	0.395				
Multego	09/1997-					
Citybus O 345	09/1999-	0.273				

SETRA

Modell • model modèle modelo modelo модель	Typ • type tipo • тип tip	Klasse • class clase • classe • class • Класс • sınıf	II	IV	V	VI
200	S 210 H		0.253 / 0.258	—		
	S 213 UL					
	S 215 HD					
	S 216 HDS					
	S 219 SL					
	S 228 DT		—			
300	215 HD	1995 - 02/04		0.280	—	
400	S 411 HD - S 417 HDH	09/1999 -		0.399	—	

VOLVO

Modell • model modèle modelo modelo модель	Typ • type tipo • тип tip	Klasse • class clase • classe • class • Класс • sınıf	II	IV	V	VI
F 86 F88 F89		08/85 - 06/77	0.255	—		
F 6		12/77 - 08/85	0.253	—		
F 10		09/85 - 09/93	0.252	0.261	—	
F 12			0.252	0.261	0.156/6 BO	
F 16		39.3730.210 39.3730.410	39.1900.210 39.1900.410			
FS 7		w	0.252	0.261	—	
FS 10				—		
N 10		1972 - 08/85	0.252	0.261	—	
NL 10				—		
NL12				—		
FL 6		09/85 - 09/93	0.252 / 0.253	0.260 / 0.261	0.360 0.156/4 BO	0.552-1 0.389
FL 7		09/85 - 09/94	0.252	0.261	—	
FL 10			0.252	0.261	0.156/6 BO	
			39.3730.210 39.3730.410	39.1900.210 39.1900.410		
FL 12			39.3730.210 39.3730.410	39.1900.210 39.1900.410		
FLC			0.252	0.261	—	
FM	7 / 9 / 10 // 12	08/98 - 03/02	0.370		0.360	
FH	12 / 16	10/93 - 03/02	0.371		0.360-1	
NH	12	05/99 -				
FH II		04/2002 -	0.224		—	
FM II						
FL		09/2006 -	0.390		0.558	59.5524.638H
FE						
Busse buses	303		0.271	—		
	603					
	B 10 Coach					
	B 12 Coach					
	8500 Coach					
	9700 Coach					
	9900 Coach					
	8700 Citybus					
	8700 low entry			0.373	0.377	
V 7000 Citybus						
8300	09/2004 -	0.274	—			

RENAULT

Modell • model modèle modelo modelo модель	Typ • type tipo • тип tip	Klasse • class clase • classe • class • Класс • sınıf	II	IV	V	VI
Magnum		02/1992 -	0.286	0.287	—	59.5524.738H
Premium	Gamme R/G	- 09/2005	0.470	—	—	0.552-1 0.389
Midlum	1818					
Premium	Distribution	05/2006 -	0.390		0.558	0.552
Premium	Route 2711					
Kerax						

SCANIA

Modell • model modèle modelo modelo модель	Typ • type tipo • тип tip	Klasse • class clase • classe • class • Класс • sınıf	II	IV	V	VI
alte Baureihe / old series		- 10/1981	0.259	—		
Serie series „3“	93		0.257	0.156/6 BO	—	
	113	10/81 - 1996 -				
	143					
Baureihe series	94	1996 - 07/04			0.156/6 BO	0.552-1
	114				0.558	0.389
	124					
	144					
	164					
4 R	08/2004 -			0.552	0.552	
4 P				0.552-1		
4 T						
Bus	Omnicity		0.373	—		

VW

Modell • model modèle modelo modelo модель	Typ • type tipo • тип tip	Klasse • class clase • classe • class • Класс • sınıf	II	IV	V	VI
Bully	—	05/79 - 07/82	—			
Caravelle	—		0.198		—	
LT	28 D		—			
	28	01/1996 -	0.349			
	35					
	31					
	45	0.110				
	50					
Crafter		05/2006 -	0.589		—	
T4	Transporter	07/1990 -	0.196		—	
Caddy			0.922		—	
T5		10/2003 -	0.923		—	

e1		Typ · type tipo · тип тип	
II e6 01*116	250		
II e2 01*130	285		
II e2 01*307	291 (Iveco)		
	253 ♦		
II e2 02*717	289		
II e2 00 718	249 L		
II e2 02*739	253		
II e2 02*740	0.258		
II e2 02*752	0.286		
II e1 03*0002	0.575		
IV e1 03*0003	577		
IV e5 02*0003	156/6 BO		
V e5 02*0004	156/6 BO		
III/III e1 03*0006	589		
III e1 03*0007	570		
IV e1 03*0008	571		
II e1 03*0009	390		
IV e1 03*0010	390		
V e1 03*0011	558		
V e1 02*0013	379-1		
IV e1 03*0014	906		
V e1 03*0015	365-1		
	394-1		
VI e1 03*0016	389		
VI e1 03*0017	396		
II e1 03*0018	378-1		
IV e1 02*0019	377-1		
II e1 02*0022	380-1		
II e1 03*0022	363		
	276		
IV e1 03*0023	381-1		
II e1 03*0024	392-1		
IV e1 03*0025	393-1		
II e1 03*0031	572		
IV e1 03*0032	573		
V e1 03*0033	552-1		
IV e1 03*0037	390		
V e1 02*0039	360-1		
II e1 03*0047	273		
	395 / 0.399		
II e1 03*0082	274		
II e1 03*0084	277		
II e1 03*0088	363		
	276		
II e1 03*0097	580 (MAN)		
IV e1 03*0098	580 (MAN)		
V e1 03*0109	579		
II e1 03*0128	278		
IV e1 03*0129	278		
V e1 03*0185	348		
II e1 02*0382	385 ♦		
II e1 02*0384	349		
II e1 01*0391	282		
II e1 01*0392	283		
IV e1 01*0394	367		
II e1 01*0395	368		
II e1 02*0418	349		
II e1 01*0423	373 / 380		
II e1 02*0423	363		
	276		
IV e1 01*0424	386 / 381		
II e1 02*0447	281		
IV e1 02*0448	281		
IV e1 02*0462	377		
II e1 02*0463	378		
V e1 02*0464	379		
II e1 01*0469	385		
II e1 02*0505	375		
II e1 02*0524	271 / 276		
	363		
III e1 02*0569	198		
II e1 02*0620	273		
II e1 02*0646	392		
IV e1 02*0647	393		
V e1 02*0647	284		
II e1 02*0662	374 (LDV)		
V e1 02*0742	552		
II e1 01*0798	901 (Iveco)		
II e9 01*1047	373		
IV e9 01*1054	386		
II e9 01*1063	460		
II e9 01*1073	373		
IV e9 01*1074	386		
V e9 01*1075	463		
II e4 02*1104	110		
II e4 01*1106	257		
II e4 02*1201/1202	253		
II e4 02*1201/1202	254		

e1		Typ · type tipo · тип тип	
II e4 02*1201/1202	258		
II(0) e11 01*1319	39.3730.210H		
	39.3730.410H		
II(0) e11 02*1323	39.3730.210H		
	39.3730.410H		
II e2 1324	39.1900.210		
	39.1900.410H		
IV e11 02*1325	39.1900.210		
	39.1900.410H		
II e11 02*1327	39.3730.210H		
	39.3730.410H		
II e11 03*1328	39.3730.210H		
	39.3730.410H		
IV e11 02*1331	39.1900.210		
	39.1900.410H		
IV e11 02*1332	39.1900.210		
	39.1900.410H		
IV e13 02*1358	263 (Iveco)		
V e13 02*1359	263 (Iveco)		
IV e1 00 1392	39.4050.210H		
IV e13 02*1392	264		
IV e1 02*1550	264		
V e1 02*1551	264		
II e13 02*1558	253		
e4 01*2067	254		
II e4 02*2069	259		
II e4 01*2083	252		
II e1 *2407	244 A ♦♦		
II e1 *2901	156/6 BO		
II e11 01*3701	255		
II e11 01*3706	364		
II e11 01*3709	257		
II e11 01*3716	253		
II e11 01*3717	252		
II e3 01*3890	472 (Iveco)		
II e3 02*3890	472 (Iveco)		
II e1 *4051	253		
IV e11 01*5002	156/6 BO		
V e11 01*5002	156/6 BO		
II e2 02*5004	348		
II e11 01*5340	253		
II e11 01*5343	257		
II e11 01*5383	258		
II e11 01*5387	255		
II e11 01*5392	364		
II e11 01*5393	254		
II e11 01*5394	252		
II e11 01*5395	251 K		
II e11 01*5396	341		
IV e11 01*5398	261		
IV e11 01*5399	266		
IV e11 01*5420	260		
II e11 01*5421	249 L		
V e11 01*5422	265		
II e11 01*5464	254		
IV/V e11 01*5465	156/6 BO		
III e11 01*5502	200 (Ford)		
IV e6 02*6565	261		
II e6 02*6566	252		
II e6 02*7060	253		
IV e6 02*7061	39.1781.210		
V e6 02*8104	0.263		
II e2 03*05023	0.348		
V e1 *10025 ♦	156/4 BO		
I e1 02*10041	202		
II e1 *10042	152 A/S		
IV e1 02*11001	260		
II e1 *11002	156/6 BO		
IV e1 02*11003	283		
IV e1 *11004	266		
IV e1 02*11005	268		
IV e1 *11006	267		
IV e1 02*11007	266		
IV e1 02*11008	266		
IV e1 02*11009	266		
IV e1 02*11010	462		
IV e1 02*11011	367		
IV e1 02*11012	285		
IV e1 02*11013	268		
IV e1 02*11014	267		
IV e1 *11015	266		
IV e1 02*11016	371		
V e1 02*12001	156/5 BO		
V e1 *12002	156/2 BO		
V e1 02*12003	284		
V e1 *12004	156/6 BO		
V e1 *12005	265		

e1		Typ · type tipo · тип тип	
V e1 02*12006	265		
V e1 02*12007	265		
V e1 02*12008	265		
V e1 02*12009	463		
V e1 02*12010	269		
V e1 02*12011	361 ♦♦		
V e1 02*12012	156/5 BO		
	156/4 BO		
V e1 02*12013	360		
V e1 02*12015	365		
	394		
II e1 *14001	250		
II e1 01*14002	250		
II e1 01*14004	364		
II e1 *14005	250		
II e1 *14006	244		
II e1 01*14007	245 ♦♦		
II e1 *14008	244 A ♦♦		
II e1 01*14010	152 ASK(B)		
II e1 01*14012	244		
II e1 01*14015	364		
II e1 *14016	251 K		
II e1 01*14019	364		
II e1 *14020	244 A ♦♦		
II e1 01*14022	253		
II e1 *14024	254		
II e1 *14025	244 A ♦♦		
II e1 *14028	289		
II e1 *14029	153 N		
II e1 *14030	156/1 BO		
II e1 02*14031	254		
II e1 02*14032	254		
II e1 *14033	255		
II e1 *14034	250		
II e1 02*14035	249L		
	249L (14-20)		
II e1 01*14036	252		
II e1 01*14037	258		
II e1 01*14038	258		
II e1 01*14039	450 (Iveco)		
II e1 *14040	258		
II e1 01*14041	253		
II e1 02*14042	253		
II e1 01*14043	254		
II e1 01*14044	253		
II e1 01*14045	258		
II e1 01*14046	244		
II e1 01*14047	251 K		
II e1 01*14048	289		
	*14049 253		
II e1 01*14050	251 K		
II e1 02*14053	320		
II e1 02*14054	300 / 310		
II e1 *14055	253		
II e1 *14057	364		
II e1 01*14058	300 / 310 ♦		
II e1 01*14059	257		
II e1 01*14062	249 L		
II e1 01*14066	153 N ♦		
II e1 02*14067	253		
II e1 01*14068	254		
II e1 01*14069	258		
II e1 01*14070	254 ♦		
II e1 01*14071	255		
	256		
II e1 02*14072	258		
II e1 02*14073	40.4495.222		
	253		
II e1 *14075	251 K		
II e1 02*14076	152 A/S		
II e2 02*14080	364		
II e1 02*14082	364		
II e1 02*14083	282		
II e1 02*14084	282		
II e1 *14085	340 / 341		
II e1 *14086	253		
II e1 02*14087	341		
II e1 02*14088	249 L		
II e1 02*14089	252		
II e1 02*14090	251 K		
II e1 *14091	253		
II e1 02*14092	254		
II e1 *14093	253		
II e1 *14094	253		
II e1 01*14095	254		
II e1 01*14096	253		

e1		Typ · type tipo · тип тип	
02*14097	258		
II e1 02*14098	340 / 341		
II e1 02*14099	254		
II e1 02*14100	330 / 331		
II e1 02*14101	341		
II e1 02*14102	460		
II e1 02*14103	461		
II e1 02*14105	368		
II e1 02*14108	254		
II e1 02*14109	254		
II e1 02*14111	385 ♦		
II e1 02*14112	258 (asph.)		
II e1 02*14117	280		
II e1 01*14119	249 L		
II e1 02*14121	366		
II e1 02*14123	368		
II e1 01*14124	340 / 341		
II e1 02*14125	370		
II e1 02*14126	371		
II e1 02*14142	364		
III e1 01*17023	249 A ♦♦		
	249 K		
III e1 01*17067	53.3002.961		
II e1 *17087	151 K		
III e1 01*17098	249 A ♦♦		
	249 K		
II e1 *17105	156/4 BO		
II e1 *17140	249 K		
II e1 01*17149	198		
III e1 01*17194	200 (Ford)		
III e1 02*17324	196		
II e1 02*17335	249 L		
II *18792	572		
II e19 46R 19506	282		
II e3 *30011	472 (Iveco)		
II e3 *30595	467 (Iveco)		
II e3 *32806	467 (Iveco)		
II e3 *32906	472 (Iveco)		
II e3 *32908	474 (Iveco)		
II e3 *33488	473 (Iveco)		
II e3 *33491	472 (Iveco)		
II e3 *34767	472 (Iveco)		
II e3 *35216	472 (Iveco)		
II e3 *35433	472 (Iveco)		
II e3 *35911	474 (Iveco)		
II e3 01*36030	474 (Iveco)		
II e3 *36709	341		
II e3 *36710	473 (Iveco)		

Typ · type
tipo · тип
tip

II	E6	00208	0.250
II	E2	00752	0.286
IV/V	E2	00753	0.287
II	E2	00759	0.254 ♦
IV	E5	01019	0.156 / 6 B0
V	E5	01020	0.156 / 6 B0
II	E6	006566	0.252
II	E6	007059	0.253
II	E1	010384	0.349
IV	E1	010392	0.283
IV	E1	010394	0.367
II	E1	010418	0.349
II	E1	010423	0.276
			0.363
			0.373
IV	E1	010424	0.386
II	E1	010447	0.281
II	E1	010448	0.281
IV	E1	010462	0.377
II	E1	010463	0.378
V	E1	010464	0.379
II	E1	010469	0.385
II	E1	010505	0.386 / 0.398
II	E1	010524	0.363
			0.271 / 0.276
III	E1	010569	0.198
II	E1	010620	0.273
			0.395 / 0.399
II	E1	010646	0.392
IV	E1	010647	0.393
V	E1	010742	0.552
II	E4	011104	0.110
II	E4	012069	0.259
V/VI	E1	020894	0.552-1
II/III	E1	020902	0.589
II	E1	020905	0.276
			0.363
II	E1	020910	0.274
V	E1	020912	0.558
IV	E1	020913	0.390
II	E1	020914	0.390
II	E1	020915	0.227
IV	E1	020916	0.390
IV	E1	020917	0.573
II	E1	020918	0.572
II	E1	020923	0.276
			0.363
II	E1	020926	0.273
			0.395 / 0.399
II	E1	020929	0.580 (MAN)
IV	E1	020930	0.580 (MAN)
II	E1	020951	0.278
IV	E1	020952	0.278
III	E1	021020	0.922
III	E1	021021	0.922
IV	E1	021023	0.348
II	E13	0087293	0.253
IV	E1	0111008	0.266
IV	E1	0111010	0.462
IV	E1	0111012	0.285
IV	E1	0111016	0.371
V	E1	0112003	0.284
V	E1	0112007	0.265
V	E1	0112009	0.463
V	E1	0112010	0.269
V	E1	0112011	0.361 ♦♦
V	E1	0112012	0.156 / 4 B0
V	E1	0112013	0.360
V	E1	0112015	0.365 / 0.394
II	E1	0114035	0.249 L
II	E1	0114053	0.320
II	E1	0114067	0.253
II	E1	0114069	0.258
II	E1	0114082	0.364
II	E1	0114083	0.282
II	E1	0114089	0.252
II	E1	0114098	0.340 / 0.341
II	E1	0114100	0.330 / 0.331
II	E1	0114102	0.460
II	E1	0114103	0.461
II	E1	0114117	0.280
II	E1	0114123	0.368
II	E1	0114125	0.370
II	E1	0114126	0.371
II	E3	0156297	0.470
II	E3	0157571	0.461
II	E3	0158121	0.460
IV	E3	0158232	0.462
IV	E13	0187290	0.264
IV	E13	0187291	0.264

♦ Alternative náhradní
alternativa альтернатива
alternativ alternatif♦♦ 472 = 51.4372.127 IVECO
244A = 51.2430.227H Mercedes
245 = 51.2450.227 Mercedes
249A = 51.2490.211H Mercedes
361 = 56.3610.127H DAF

MEKRA					Splitter- schutz shatter proof	Fahrzeughersteller vehicle manufacturer constructeur du véhicule costruttore del veicolo	MEKRA					Splitter- schutz shatter proof	Fahrzeughersteller vehicle manufacturer constructeur du véhicule costruttore del veicolo
39.1480.610	plan / flat	148	148	-			40.2890.122F	1800	300	214	-		Steyr
40.1475.103F	300	147	rund	-			40.2890.222H	1800	300	214	-	✓	Fendt/AGCO, Steyr
39.1720.210H	400	171	171	-	✓	Mercedes	40.2890.422H	1800	300	214	24 V	✓	Fendt/AGCO, Steyr
39.1720.410H	400	171	171	24 V	✓	Mercedes	40.3005.222	1800	300	rund	-	✓	
39.1781.210	400	178	160	-	✓		40.2435.222F	1800	301	177	-	✓	Mercedes
40.1510.122H	1800	178	122	-		diverse Schlepper-Hersteller various tractor manufacturers	40.2750.222F	1800	306	191	-	✓	
40.1510.700F	plan / flat	178	122	-	✓	diverse Schlepper-Hersteller various tractor manufacturers	40.2510.222H	1800	308	176	-	✓	MAN
40.2750.206	600	188	122	-	✓		40.2510.322H	1800	308	176	12 V	✓	MAN
40.2605.204H	400	190	143	-	✓	MAN	40.2510.422H	1800	308	176	24 V	✓	MAN
40.2600.404H	400	190	143	24 V	✓	MAN	40.3655.204	400	311	171	-	✓	MAN
40.5735.203H	300	190	184	-	✓	MAN	40.3650.404H	400	311	171	24 V	✓	MAN
40.5735.403H	300	190	184	24 V	✓	MAN	39.3120.210H	1800	312	180	-	✓	MAN
39.1900.210	400	193	156	-	✓	DAF, Ford, Volvo	39.3120.410D	1800	312	180	24 V	✓	MAN
39.1900.410H	400	193	156	24 V	✓	DAF, Ford, Volvo	39.3140.110H	1800	314	174	-		
40.2495.214F	1400	195	125	-	✓	Mercedes	40.2635.204F	400	315	178	-	✓	Iveco
40.2620.204	400	199	180	-	✓	Volvo	39.3190.210	400	319	163	-	✓	Mercedes
40.2665.104H	400	199	149	-	✓	MAN	39.3340.110H	1800	334	169	-		
40.2665.204H	400	199	149	-	✓	MAN	40.4495.222	1800	344	164	-	✓	Iveco, DAF
40.2660.404H	400	199	149	24 V	✓	MAN	40.4372.222H	1800	345	195	-	✓	Iveco
40.2875.404H	400	200	151	24 V	✓	Renault	40.3665.118F	1800	355	170	24 V	✓	
39.2050.110	400	205	188	-	✓	Mercedes	40.2530.222H	1800	356	170	-	✓	Iveco, Merc., Volvo
39.2050.410	400	205	188	24 V	✓	Mercedes	40.2530.322	1800	356	170	12 V	✓	Mercedes
40.2085.214	1400	208	rund	-			40.2530.422H	1800	356	170	24 V	✓	Iveco, Merc., Volvo
40.2085.700F	plan / flat	208	rund	-	✓		40.3640.222H	1800	363	174	-	✓	MAN
40.3675.204H	400	209	169	-	✓	Mercedes	40.3640.322H	1800	363	174	12 V	✓	MAN
40.3670.404H	400	209	169	24 V	✓	Mercedes	40.3640.422H	1800	363	174	24 V	✓	MAN
40.2685.204H	400	211	161	-	✓	MAN	40.3400.422	1800	363	174	24 V	✓	MAN
40.2680.404	400	211	161	24 V	✓	MAN	40.3655.320H	1800	365	186	24 V	✓	Neoplan
40.2615.204	400	213	213	-	✓	Volvo	40.2455.222F	1800	366	174	-	✓	Mercedes
40.2610.404H	400	213	213	24 V	✓	Volvo	40.2500.222H	1800	366	176	-	✓	Iveco, MAN, Volvo
40.2491.122H	1800	235	145	-		Mercedes	40.2500.322	1800	366	176	12 V	✓	MAN
40.2491.222X	1800	235	145	-	✓	Mercedes	40.2500.422H	1800	366	176	24 V	✓	Iveco, MAN, Volvo
40.2440.122X	1800	240	150	-		MAN, Mercedes	40.3200.422H	1800	366	176	24 V	✓	MAN
40.2440.204X	400	240	150	-	✓	MAN, Mercedes	40.2505.600F	plan / flat	367	177	-		Volvo, Scania
40.1565.104F	400	241	143	-		MAN	40.3485.412E	1200	372	189	24 V	✓	DAF, Renault
40.1565.106F	600	241	143	-		MAN	39.3730.110H	1800	373	190	-		DAF, Ford, Volvo
40.2655.204	400	241	150	-	✓	MAN	39.3730.210H	1800	373	190	-	✓	DAF, Ford, Volvo
40.1525.108	800	252	141	-			39.3730.410H	1800	373	190	-	✓	DAF, Ford, Volvo
40.1525.114H	1400	252	141	-		Fendt/AGCO, Merc.	39.3920.210	1800	392	173	-	✓	Mercedes
40.1525.222F	1800	252	141	-	✓	Fendt/AGCO, Merc.	39.3920.410H	1800	392	173	24 V	✓	Mercedes
40.1525.114H	1400	252	141	-		Fendt/AGCO, Merc.	39.3940.118	1800	394	154	-		Pegaso
40.3611.104F	400	250	144	-		DAF	39.3960.110H	1800	396	200	-		
40.1561.105H	400	250	150	-		Scania, Volvo	39.4020.410H	1800	402	181	24 V	✓	Mercedes
40.4485.114	1400	250	170	-		MAN	39.4050.110X	1800	405	205	-		
39.2530.110H	1800	253	152	-			40.2580.222H	1800	408	184	-	✓	Mercedes
40.2590.114H	1400	257	155	-			40.2580.422H	1800	408	184	24 V	✓	Mercedes
40.2647.204H	400	260	148	-	✓	Iveco	40.2460.214H	1400	410	210	-		MAN
40.2640.404	400	260	148	24 V	✓	Iveco	40.2460.600	plan / flat	410	210	-		MAN
40.1524.114H	1400	260	150	-		Mercedes	40.5725.112F	1200	412	188	12 V	✓	MAN
40.1524.115H	1400	260	150	-		Iveco	40.5725.212H	1200	412	188	-	✓	MAN
40.2485.214	1400	260	150	-			40.5725.412H	1200	412	188	24 V	✓	MAN
40.3605.204	400	271	161	-	✓	Volvo	39.4170.210H	1800	417	196	-	✓	Mercedes
40.3600.404	400	271	161	24 V	✓	Volvo	39.4170.410H	1800	417	196	24 V	✓	Mercedes
40.3605.203H	300	271	161	-	✓	Volvo	40.2570.222H	1800	417	221	-	✓	Scania
40.3605.403H	300	271	161	24 V	✓	Volvo	40.2570.422H	1800	417	221	24 V	✓	Scania
40.2695.204H	400	281	151	-	✓	Mercedes	40.3680.222H	1800	427	169	-	✓	Mercedes
40.4373.222	1800	284	155	-	✓	Iveco	40.3680.422H	1800	427	169	24 V	✓	Mercedes
40.4495.114	1400	287	197	-		KHD	40.2520.222H	1800	429	194	-	✓	Volvo, Iveco
39.2900.110	1400	290	171	-			40.2520.422H	1800	429	194	24 V	✓	Volvo, Iveco
40.2540.222H	1800	291	170	-	✓	Mercedes, MAN	40.2525.700F	plan / flat	429	194	-	✓	Volvo, Iveco
40.2540.422H	1800	291	170	24 V	✓	Mercedes, MAN	40.3300.218H	1800	429	199	-	✓	Claas
40.2550.222H	1800	298	208	-	✓	Volvo, Scania	40.3302.418H	1800	429	199	24 V	✓	
40.2550.422H	1800	298	208	24 V	✓	Volvo, Scania	39.4580.410H	1800	458	181	24 V	✓	Renault (Magnum)
40.2555.600	plan / flat	298	208	-		Volvo, Scania							



AGCO → FENDT

CASE New Holland (CNH)

06259310	14.2520.200	-
1 975 766 C 1	51.1511.111H	-
1 975 807 C 1	21.2020.311	-
1 975 808 C1	11.0010.100	-
1-34-677-6541	51.1511.113H	-
176 82-AA	51.2540.120H	56
2 783 857 R1	59.1511.110	-
3 221 522 R 1	51.1522.121	-
3 221 522 R 2	51.1522.121	-
3 224 516 R 1	51.1511.113H	-
3 224 516 R 2	51.1511.113H	-
3 224 705 R 1	51.1520.213H	-
3 224 705 R 2	51.1520.213H	-
3 399 576 R 91	51.2440.117H	55
437 650	51.2550.127H	82
796 067	51.2550.127H	82
81871843	51.2540.128H	-
84433427	20.2480.210H	106
844334473		26, 53, 54, 90, 100, 103
844334474	11.3730.210H	26
844334478	11.3860.500H	42
9 501 005	15.3731.373	42
901 005	51.2540.120H	56

Caterpillar

236-0422	51.3731.324	-
236-2147	51.3732.324	-
290-5544	51.3635.201	100
290-5545	51.3636.201	100
294-1991	51.3635.204	100
294-1992	51.3636.204	100
308-3842	15.3731.370	-
3083840	11.3860.500H	26

Claas

01817890	11.3400.510	-
05805030	51.3310.127H	-
06259300	40.3300.218H	-
06439980	56.2650.121H	43
131170	08.3200.233H	91, 107

DAF

0067 657	40.2530.222H	36, 56, 82
0067 658	40.2530.422H	82
0067 659	40.2580.422H	57
0067 661	61.2530.110H	36, 56, 57, 82
0375 527	56.3610.127H	-
0589 435*	39.3730.410H	27, 33, 89
0589 436*	39.3730.210H	27, 33, 89
0589 437*	39.1900.410H	27, 33, 89
0589 438*	39.1900.210	27, 33, 89
0649 714	51.3640.127H	40
0699 853	39.1900.210	27, 33, 89
0699 854	39.1900.410H	27, 33, 89
0699 856	39.3730.210H	27, 33, 89
0699 857	39.3730.410H	27, 33, 89
0699 956	39.3730.210H	27, 33, 89
0892 893	56.2600.127H	41
0892 894	56.2600.147H	-
0892 895	51.2530.110H	36, 56, 82
0892 896	51.2530.140H	36, 56, 82
0892 897	51.2580.120H	57
0892 898	51.2580.140H	57
1305 462	39.3730.410H	27, 33, 89
1315 311	56.3610.127H	-
1401 046	59.5580.147H	30, 74, 76, 86
1404 849	40.3485.403E	27
1404 868	61.3482.149H	27, 78
1404 871	61.3480.149H	27, 78
1404 872	15.4700.470H	-
1404 974	15.4700.270H	-
1405 062	13.3480.110E	-
1405 295	61.3480.149H	27, 78
1405 350	61.3482.149H	27, 78
1405 601	51.4700.113H	-
1409 570	59.5580.147H	30, 74, 76, 86
1409 962	59.5580.247H	30, 74, 76, 86
1425 104	61.3730.324H	26
1425 105	61.3730.326H	26
1425 108	61.3860.214H	26
1425 109		26, 53, 54, 90, 103
1425 111	15.3731.470H	26
1425 113	15.3861.114H	26
1425 114	11.3730.210H	26, 53, 54, 90, 100, 103
1425 120	11.3860.500H	26
1425 120	58.5541.400E	-
1442 102	61.3730.110	-



DAF

1457 049	20.5541.510F	-
1525 594	56.1561.115H	-
1526 116	59.5520.030H	81
1526 524	15.4621.870H	-
1526 525	15.4631.870H	-
1527 774	15.4630.870H	39
1610 182	15.3811.870H	45
1610 184	61.3730.326H	26
1610 186	61.3730.324H	26
1610 187	61.3860.214H	26
1610 189	61.3865.124H	26
1610 190		26, 53, 54, 90, 103
1610 191	15.3731.470H	103
1614 021	15.3861.114H	26
1614 022	59.5520.140H	29
1614 631	59.5520.240H	29
1618 788	59.5528.240	-
1620 023	59.5528.260	-
1620 025	51.4700.111H	-
1620 091	09.2000.301H	42, 43, 106
1620 226	51.5524.140	-
1620 228	40.3640.422H	40, 42
1637 319	40.2660.404H	43
1644 323	56.2640.147	-
1644 324	20.5700.420H	28
1644 325	20.5700.410H	28
1644 326	11.5700.100H	28
1645 467	11.5710.110H	28
1669 573	20.2480.216H	53, 90, 103, 106
1670 877	59.5525.230H	29
1670 878	61.9065.114H	26
1670 888	15.9060.870H	26
1684 030	11.9060.100H	26
1684 031	59.5525.131H	29
1684 032	59.5525.132H	29
1684 033	59.5525.133H	29
1684 034	59.5525.134H	29
1684 035	59.5525.135H	29
1684 042	59.5525.136H	29
1684 043	59.5525.235H	29
1684 046	59.5525.236H	29
1684 047	59.5525.331H	29
1685 324	59.5525.332H	29
1685 325	58.5701.100H	28
1685 326	58.5701.200H	28
1685 327	58.5701.310H	28
1685 330	58.5701.410H	28
1685 331	15.5701.840H	28
1689 347	57.5711.870H	28
1689 348	61.5710.310.099	28
1692 556	61.5700.310.099	28
1692 557	61.5710.210H	28
1693 456	61.5700.210H	28
1693 457	58.5711.220H	-
1693 458	58.5711.210H	-
1693 459	58.5711.120H	-
1698 180	58.5711.110H	-
1700 265	20.5521.100	29
1700 269	59.3900.133H	30, 74, 86
1700 303	59.3900.233H	31, 75, 87
1700 304	59.3900.143H	30, 74, 86
1700 306	59.3900.132H	30, 74, 86
1700 307	59.3900.243H	31, 75, 87
1700 309	59.3900.232H	31, 75, 87
1700 961	59.3900.142H	30, 74, 86
1700 963	59.3900.242H	31, 75, 87
1701 288	59.5524.648.099	31, 77
1704 974	15.4700.470H	-
1733 888	58.3900.343H	30, 74, 76, 86
1733 891	58.3900.443H	31, 75, 77, 87
1733 892	58.3900.143H	30, 74, 76, 86
1733 893	58.3900.243H	31, 75, 77, 87
1735 519	61.3900.110H	30, 74, 76, 86
1735 520	61.3900.120H	31, 75, 77
1735 521		30, 31, 74, 75, 86, 87
1735 522	61.3900.100H	30, 74, 86
1735 523	61.3911.110H	30, 74, 86
1736 851	61.3911.120H	31, 75, 87
1736 852	58.3900.433H	31, 75, 87
1736 853	58.3900.333H	30, 74, 86
1736 854	58.3900.233H	31, 75, 87
1736 855	58.3900.133H	30, 74, 86
1736 865	15.3911.872H	31, 75, 87
1736 879	15.3911.871H	30, 74, 86
1736 883		30, 31, 74, 75, 86, 87
1736 884	11.3910.200H	30, 31, 74, 75, 86, 87
1736 891	11.3900.200H	30, 31, 74, 75, 86, 87
1736 892	08.5751.324E	31, 75, 77, 87
1736 897	08.5751.424E	30, 74, 76, 86
1736 917	20.5580.140E	30, 31, 75, 77, 87
1736 918	20.5580.130H	30, 74, 76, 86



DAF

1736 919	20.5580.120H	31, 75, 77, 87
1736 920	20.5580.110H	30, 74, 76, 86
1736 923	20.3900.520H	31, 75, 77, 87
1736 924	20.3900.510	30, 74, 76, 86
1736 951	58.3900.433H	31, 75, 87
1736 952	58.3900.333H	30, 74, 86
1736 953	58.3900.233H	31, 75, 87
1736 954	58.3900.133H	30, 74, 86
1737 005	58.3900.349E	-
1737 006	58.3900.449E	-
1737 933		30, 31, 74, 75, 76, 77, 86, 87
1781 224	15.3900.840H	-
1781 225	61.3902.110H	-
1781 226	61.3902.120H	-
1781 227	61.3902.100E	-
1781 228	61.3913.110H	-
1788 485	61.3913.120H	-
1788 486	58.5714.210H	28
1788 487	58.5714.220H	28
1788 488	58.5714.110H	28
1788 972	58.5714.120H	28
1788 973	58.5713.120H	28
1788 974	58.5713.210H	28
1788 975	58.5713.220H	28
1796 324	61.3482.149H	27, 78
1796 325	40.3485.403E	27
1796 327	40.5525.204F	-
180 5712	61.3480.149H	27, 78
1805 714	61.3481.149H	27
1805 717	15.3480.840H	27
1812 862	61.5700.310.099	28
1817 860	61.5710.310.099	28

DaimlerChrysler → Mercedes Benz

Deutz → KHD

Evobus → Mercedes & Setra

FAUN

011 8683	51.1512.211H	-
012 4983	51.2460.215	-
072 7836	51.1520.212H	99
129 655	51.1520.213H	-
264 70 77	51.1520.211H	99
264 7088	51.2462.217H	-
264 71 17	40.2460.214H	104
264 7144	51.1520.215	-
264 72 45	51.2500.127H	36, 82
264 7247	58.2500.210H	-
264 73 05	51.2500.147H	36, 82
264 73 09	51.1512.211H	-
264 73 23	51.1511.112H	-
264 73 25	51.3640.127H	40
264 73 35	51.3640.147H	40
264 73 36	51.2520.147H	83
264 73 41	55.2020.177H	104
264 73 44	56.2610.127H	83
264 7311	51.2461.117H	-
269 5075	40.1524.114H	-
269 52 36	40.2500.222H	36, 82
269 56 77	20.2600.511H	108
269 56 78	20.2600.112H	108
269 56 84	40.3640.422H	40, 42
415 81 08	51.1511.219H	98
420 04 24	51.1512.211H	-
421 0886	58.2423.610H	-
479 7466	58.2423.310H	-
700 03 82	51.2576.127H	80
772 31 66	56.2441.118H	41
772 31 95	56.1523.117H	99
772 36 11	51.2530.120H	36, 56, 82
772 36 12	61.2530.110H	36, 56, 57, 82
772 36 13	56.2640.127H	36
772 36 17	51.2530.140H	36, 56, 82
772 36 18	56.2640.147	-
800 6583	51.2550.127H	82

FENDT

E 178.810.150.010	51.1524.119H	32
E 178.810.150.019	51.1524.119H	32
E 198 810 150 019	51.3200.137H	-
E178.810.150.010	51.1524.119H	32
E178.810.150.020	51.1524.122H	-
E178.810.150.029	51.1524.121	-
E258.514.270.020</		

OE



FENDT

F 198 810 150 010	08.3200.250H	107
F 291 500 270 020	40.2500.222H	36, 82
F178.810.150.010	40.1521.222X	-
F178.810.150.020	51.1524.119H	32
F198.810.150.030	40.2500.322	-
F291.500.270.030	14.2500.100	-
G 291 500 270 030	51.2500.127H	36, 82
G 291 500 270 040	58.2500.210H	-
G 297 810 150 010	40.2890.222H	32, 98
G 297 810 150 030	51.3850.127H	32
G 816 810 150 030	51.2890.117H	98

FORD

1053410	51.3300.147H	34
1053412	51.5552.210H	-
1053418	51.5551.110H	-
1053420	51.5551.210H	-
1141722	51.9310.410H	33
1641745*	39.3730.210H	27, 33, 89
1641752*	39.3730.410H	27, 33, 89
1653450*	39.1900.410H	27, 33, 89
1653451*	39.1900.210	-
4087272	51.9310.120H	33
4158406	51.9310.110H	33
4158420	51.9310.420H	33
6166607	39.3730.210H	27, 33, 89
6166609	39.3730.410H	27, 33, 89
6186601	39.1900.210	27, 33, 89
6186603	39.1900.410H	27, 33, 89
6831642	53.2002.130	-
6831666	53.2002.110	-
6831674	53.2002.220	-
6831697	53.2001.110	-
6831705	53.2001.220	-
6831721	53.2001.130	-
6838666	51.3850.127H	32

FRITZMEIER

119 392	51.1511.219H	98
119393	40.1510.122H	98
129 655	51.1520.213H	-
2153	51.3410.127H	42
217 611	55.2020.177H	104
218 140	58.2483.841	-
218 141	58.2483.842	-
218 142	20.2480.210H	106
220 050	51.2530.128H	-
220 522	51.2491.121H	55
220 589	51.3640.127H	40
220 998	20.2600.112H	108
220 999	20.2600.111H	108
3844	55.2021.177	104
4 201 252 M 91	51.3640.127H	40
605 844	51.1511.111H	-
613 918	51.1523.121H	-
634 014	51.2500.127H	36, 82
634 026	51.2550.127H	82
662 920	51.2491.121H	55
684 251	51.3735.126H	44
684 252	51.3736.126H	44
684 253	56.3860.114H	44
684 272	08.3200.233H	91, 107
684 400	51.3402.149	-
684 405	09.3300.421	106, 107
684 406	09.3200.320H	106, 107
708 616	51.2440.117H	55
709 979	51.2440.117H	55
99707000161	08.3200.233H	91, 107
99707007256	08.3200.500	-

HINO

07 902 0007	51.3635.206	34
87 902 0002G	40.3302.418H	34
87 902 0006	51.3310.147H	34
87 902 2040A	51.2520.127H	83
87 902 7000	59.3631.322	34
87 902 7001	59.3631.422	34
87 906 7000	58.3631.322	34

Hymer

38 305 si	56.1471.217H	-
38 305 sw	56.1471.117	-
38 309	40.1524.114H	-
38 311	51.2493.127H	-
38 346	55.2020.177H	104
380 008	51.3410.127H	42
383 001	51.3200.137H	-
383 002	09.3200.410H	107
383 051	56.2600.127H	41
9 981 610	51.3200.137H	-

OE



Hymer

9 981 630	09.3200.420H	42, 107
9 982 180	56.0500.000H	100
9 982 190	56.0750.000H	100

IHC → CASE New Holland (CNH)

IRISBUS

50.00.021.163		54, 69, 91, 103, 106
50.01.403.394	20.2710.620	-
50.01.851.890	09.2810.300	-
50.01.851.891	15.2810.480H	35
50.01.851.895	11.2810.200H	35
50.01.851.895	15.2810.470H	35
50.01.852.000	20.2810.310	-
50.01.855.370	20.2810.210	-
50.06.232.165	58.2704.088	111
50.06.232.482	51.3732.326H	53, 54, 90, 103
50.06.232.483	51.3731.326	53, 54, 90, 103
50.06.232.484	20.2710.630H	53, 54, 103, 106
50.10.404.852	59.2810.113H	35
50.10.404.853	20.2810.110H	35
50.10.411.090	59.2810.111H	35
50.10.482.937	59.2810.211H	35
50.10.482.938	59.2810.213H	35
71101611	59.2710.411	103

IVECO

012 389 67	40.1524.115H	98, 99
012 389 71	51.1520.214H	-
023 763 29	51.2890.117H	98
025 619 31	51.1512.211H	-
025 654 94	58.2490.311	-
025 655 07	51.2480.217	-
025 852 53	20.2423.410	-
026 014 17	51.2500.127H	36, 82
026 058 21	58.2423.610H	-
026 125 73	40.2500.222H	36, 82
026 125 74	14.2500.100	-
026 126 14	58.2423.210	-
026 281 91	51.2500.147H	36, 82
026 281 94	40.2500.422H	36, 82
026 299 40	58.2472.051	-
043 255 57	51.1511.219H	98
046 725 87	40.4267.222	-
046 994 50	51.4267.127	-
047 239 31	51.4372.127H	-
047 239 36	40.4372.222H	-
047 555 82	51.4375.127	-
047 558 70	51.4375.147	-
047 883 51	51.4372.147H	-
048 547 29	51.9010.220H	-
048 547 30	51.9010.210H	-
048 547 31	51.9011.220H	-
048 547 32	51.9011.210H	-
077 506 25	15.9010.120H	-
077 506 26	15.9010.110H	-
081 431 13	56.4621.100H	-
081 431 20	51.4612.110H	-
081 431 21	51.4612.125	-
081 431 22	51.4612.135H	-
0814 3172	56.4621.200H	-
0814 3173	56.4621.300H	-
261 2577	11.2500.410	-
299 6670	56.4620.247H	39
299 6671	56.4620.267H	39
421 213 04	20.2423.223	-
422 000 85	51.1520.218H	98
422 092 32	56.2640.127H	36
422 092 33	56.2640.127H	36
422 092 34	40.2647.204H	36
422 093 70	61.2530.110H	36, 56, 57, 82
422 093 71	51.2530.120H	36, 56, 82
422 093 94	40.2530.222H	36, 56, 82
422 093 97	14.2530.100	-
422 093 99	61.2530.110H	36, 56, 57, 82
422 094 01	51.2530.140H	36, 56, 82
423 099 19	56.1523.117H	99
423 099 21	51.1523.111H	-
423 241 61	51.2520.127H	83
423 243 76	40.2520.222H	83
423 246 77	51.2520.147H	83
423 246 79	40.2520.422H	83
423 291 17	58.2423.610H	-
423 291 21	59.2640.110H	36
423 433 23	51.1523.111H	-
423 442 19	56.1523.117H	99
423 450 10	51.2520.127H	83
423 453 43	51.2520.147H	83
423 455 22	59.2640.110H	36
423 455 23	59.2640.110H	36
423 457 50	56.2630.127H	-

OE



IVECO

423 457 51	56.2630.127H	-
423 457 80	56.2640.127H	36
423 459 81	11.1523.212	36, 109
423 471 98	58.2430.011	-
423 471 99	58.2430.012	-
423 472 06	58.2430.111	-
423 472 07	58.2430.112	-
423 504 21	56.2640.127H	36
423 504 25	59.2640.110H	36
423 518 22	58.2436.111	-
423 518 23	58.2436.112	-
424 844 77	40.1524.115H	98, 99
425 375 12	15.2810.480H	35
425 375 14	15.2810.470H	35
425 459 85	20.2480.217H	90, 103, 106
425 459 90	15.4620.870H	26, 53, 54, 90, 100, 103
425 484 03	11.3730.210H	39
425 562 27	15.4620.870H	26, 53, 54, 90, 100, 103
425 562 28	11.3730.210H	26, 53, 54, 90, 103
425 587 13	15.3731.470H	39
500 340 779	15.4630.870H	39
500 341 056	59.2812.233	-
500 341 056	59.2810.133	-
504 132 243	59.4630.247H	39
504 132 244	59.4630.267H	39
504 132 248	56.4620.247H	39
504 132 249	56.4620.267H	39
504 150 526	59.1008.005.099	37
504 150 527	59.1008.006.099	37
504 150 534	59.1008.007.099	37
504 150 535	59.1008.008.099	37
504 150 538	59.1008.011.099	37
504 150 539	59.1008.012.099	37
504 150 551	59.1008.017.099	37
504 150 552	59.1008.018.099	37
504 168 235	56.1008.001.099	37
504 168 236	56.1008.002.099	37
504 197 878	19.1008.041.099	37
504 197 879	19.1008.311.099	37
504 224 427	55.1008.001.099	37
504 224 428	55.1008.002.099	37
860 029 37	40.4495.222	-
860 031 44	51.2530.120H	36, 56, 82
911 263 1147	56.2631.147	-
931 605 18	15.9010.220H	-
931 605 19	15.9010.210H	-
931 605 20	15.9010.120H	-
931 605 21	15.9010.110H	-
931 605 34	08.2810.224	-
931 605 36	08.2810.124	69
931 909 71	20.4601.100H	38
931 909 73	15.4622.164H	39
931 909 74	20.4621.100H	39
931 909 76	15.4611.164H	38
931 909 77	20.4611.100H	38
931 909 84	15.4632.164H	39
931 909 85	15.4631.164H	39
931 931 61	20.4610.200	38
931 931 62	15.4611.000	-
931 931 97	15.4602.164H	38
931 931 98	15.4612.164H	38
931 931 99	15.4621.164H	39
931 932 00	15.4601.000	-
931 932 01	15.4621.160	-
931 932 02	20.4600.200	38
931 932 03	20.4620.100H	39
931 932 04	20.4600.100H	-
931 932 05	20.4610.100H	38
939 040 83	51.4373.127	-
939 246 53	51.9011.120H	-
939 246 54	51.9011.110H	-
939 368 40	51.9011.210H	-
939 368 41	51.9011.220H	-
939 368 48	51.9010.140H	-
939 368 49	51.9010.220H	-
939 368 54	51.9010.110H	-
939 368 55	51.9010.120H	-
984 091 10	59.4631.200H	39
984 091 11	59.4631.300H	39
984 092 14	51.4601.110	-
984 092 15	51.4601.125	



IVECO

984 729 74	59.4631.220H	-
984 729 75	59.4631.320H	39
984 729 76	51.4601.110	-
984 729 77	51.4601.120H	38
984 729 79	51.4601.130H	38
984 729 81	51.4612.110H	-
984 729 82	51.4612.120H	38
984 729 83	51.4612.130H	38
984 729 87	56.4621.220H	39
984 729 89	56.4621.320H	-
984 730 00	59.4632.200	-
984 730 02	59.4632.300	-
984 730 05	51.4601.110	-
984 730 07	51.4601.230	38
984 730 08	51.4612.110H	-
984 730 10	51.4612.125	-
984 730 11	51.4612.230	38
984 730 12	56.4621.100H	-
984 730 13	56.4622.200	39
984 730 14	56.4622.300	-
984 874 60	15.4630.870H	39
984 874 65	15.4631.164H	39

John Deere

AZ 100258	51.3300.137	-
AZ 100260	56.2650.121H	43
AZ100261	11.1523.010	109

KHD

0 237 6392	51.2890.117H	98
0 432 5557	51.1511.219H	98
0 432 7533	51.2890.117H	98
0 433 5119	51.1523.121H	-

Kässbohrer → Setra

LDV

403740100	15.3741.362F	-
403740110	15.3741.361F	-
576100005	51.3741.014H	-
576100006	51.3742.014H	-
576100007	51.3743.014H	-
576100008	51.3744.014H	-
576100013	51.3741.114H	-
576100014	51.3742.114H	-
576100015	51.3743.114H	-
576100016	51.3744.114H	-

Liebherr

7004956	59.2442.110	-
7005028	51.3640.127H	40
7019140	51.2493.127H	-
7370320	51.3310.127H	-

Magirus → Iveco-Magirus

MAN

33.63731-6003	20.2480.219	-
36.63730-6011	59.2718.111	-
36.63731-6000		54, 69, 91, 103, 106
36.63731-6001	20.2710.620	-
81.25404-6247	20.2710.630H	53, 54, 103, 106
81.25406-6025	09.3200.310H	106, 107
81.25406-6252	09.3200.300	-
81.25428-6475	09.3200.360	-
81.25432-0149	09.3920.110H	48, 49
		40, 41, 42, 55, 56, 57, 98, 106
81.25435-0290	09.2070.101H	-
81.25505-6140	08.2470.100	-
81.25505-6247	08.3200.233H	91, 107
81.25525-0232	08.2770.001.000	52
81.36723-0087	08.3200.233H	91, 107
81.36731-6598	11.2770.920	-
81.62410-0107	58.3807.344D	-
81.62410-0108	20.5800.710H	51
81.62730-6221	20.5800.720H	51
81.63700-6091	51.3410.147H	42
81.63700-6092	59.2712.111	53
81.63730-0032	59.2712.114	53
81.63730-0040	40.3640.422H	40, 42
81.63730-0043	40.2460.414	-
81.63730-0054	40.1521.222X	-
81.63730-0058	40.2685.204H	40, 41
81.63730-0066	08.3400.324	-
81.63730-0067	15.3731.070H	44
81.63730-0068	15.3731.074H	44
81.63730-0069	15.3812.110H	-
81.63730-0079	15.3812.410H	44
81.63730-0082	51.3894.140	47
	61.2770.110	-



MAN

81.63730-0083	61.2770.210	-
81.63730-6001	51.3640.147H	40
81.63730-6003	40.3640.422H	40, 42
81.63730-6007	51.1520.211H	99
81.63730-6016	51.3400.147H	42
81.63730-6019	51.2530.120H	36, 56, 82
81.63730-6027	51.1531.115H	99
81.63730-6057	55.1990.267	-
81.63730-6094	51.2460.218H	-
81.63730-6099	51.1520.218H	98
81.63730-6106	51.1520.211H	99
81.63730-6108	51.3640.127H	40
81.63730-6126	51.3640.127H	40
81.63730-6127	51.2510.127H	40
81.63730-6128	51.2510.147H	40
81.63730-6138	56.1560.117H	41
81.63730-6140	51.2460.218H	-
81.63730-6147	51.3640.127H	40
81.63730-6148	51.2510.147H	40
81.63730-6149	51.3640.127H	40
81.63730-6151	51.3640.147H	40
81.63730-6164	51.2500.127H	36, 82
81.63730-6165	56.2680.121H	40
81.63730-6167	51.2510.127H	40
81.63730-6170	51.2890.117H	98
81.63730-6187	56.2441.118H	41
81.63730-6189	55.2461.113	104
81.63730-6193	51.3200.147H	42
81.63730-6194	51.3640.127H	40
81.63730-6195	55.2461.163H	-
81.63730-6197	51.2530.120H	36, 56, 82
81.63730-6198	51.2530.140H	36, 56, 82
81.63730-6202	40.3640.422H	40, 42
81.63730-6204	51.2580.120H	57
81.63730-6206	56.2600.127H	41
81.63730-6207	56.2441.118H	41
81.63730-6208	56.2441.118H	41
81.63730-6209	51.2530.140H	36, 56, 82
81.63730-6210	08.3200.325	-
81.63730-6216	56.2441.118H	41
81.63730-6217	56.2680.121H	40
81.63730-6219	59.2650.121H	-
81.63730-6220	51.3410.127H	42
81.63730-6221	51.3410.147H	42
81.63730-6222	56.2660.127H	43
81.63730-6223	56.2660.147H	43
81.63730-6224	56.2650.121H	43
81.63730-6233	51.3410.127H	42
81.63730-6234	51.3410.147H	42
81.63730-6235	56.2660.127H	43
81.63730-6236	56.2660.147H	43
81.63730-6237	59.2650.121H	-
81.63730-6257	51.2587.148	-
81.63730-6294	59.3941.544H	46
81.63730-6295	59.3652.147H	46
81.63730-6296	59.3652.167H	46
81.63730-6297	51.1531.115H	99
81.63730-6299	56.2660.147H	43
81.63730-6303	51.3736.121H	44
81.63730-6304	51.3736.124H	44
81.63730-6305	51.3736.126H	44
81.63730-6306	56.3860.112H	44
81.63730-6307	56.3860.114H	44
81.63730-6308	56.3862.116H	44
81.63730-6309	51.3200.146H	42
81.63730-6314	51.3735.121H	44
81.63730-6315	51.3735.124H	44
81.63730-6316	51.3735.126H	44
81.63730-6317	56.3861.116H	44
81.63730-6322	51.2500.167H	-
81.63730-6328	56.3862.116H	44
81.63730-6329	56.3817.127	-
81.63730-6331	51.3735.121H	44
81.63730-6332	51.3736.121H	44
81.63730-6345	51.3921.222H	48
81.63730-6347	51.3922.222H	48
81.63730-6350	56.3932.222H	48
81.63730-6351	56.3931.222H	48
81.63730-6352	59.3941.212H	50
81.63730-6353	59.3941.222H	50
81.63730-6361	51.3735.124H	44
81.63730-6362	51.3735.124H	44
81.63730-6363	51.3735.126H	44
81.63730-6364	51.3736.126H	44
81.63730-6365	51.3735.124H	44
81.63730-6366	51.3736.124H	44
81.63730-6367	51.3735.126H	44
81.63730-6368	51.3736.126H	44
81.63730-6369	51.3922.232H	48
81.63730-6373	08.3492.324	-
81.63730-6374	51.3732.326H	53, 54, 90, 103



MAN

81.63730-6375	51.3731.326	53, 54, 90, 103
81.63730-6390	51.3732.326H	53, 54, 90, 103
81.63730-6394	51.3924.222H	48
81.63730-6395	51.3921.222H	48
81.63730-6398	51.3923.222D	48
81.63730-6399	51.3922.222H	48
81.63730-6400	51.3923.232D	48
81.63730-6401	51.3922.232H	48
81.63730-6409	56.3931.222H	48
81.63730-6410	56.3932.222H	48
81.63730-6415	59.3941.222H	50
81.63730-6420	51.3412.120H	42
81.63730-6421	56.2662.120D	43
81.63730-6422	51.3418.120M	-
81.63730-6430	51.3921.222H	48
81.63730-6431	51.3924.222H	48
81.63730-6432	51.3922.222H	48
81.63730-6433	51.3923.222D	48
81.63730-6434	51.3922.232H	48
81.63730-6435	51.3923.232D	48
81.63730-6443	56.3931.222H	48
81.63730-6444	56.3932.222H	48
81.63730-6449	59.3941.212H	50
81.63730-6450	59.3941.222H	50
81.63730-6478	51.5720.127H	47
81.63730-6479	51.5728.127M	-
81.63730-6480	51.3921.223H	49
81.63730-6481	51.3922.223H	49
81.63730-6482	51.3921.224H	49
81.63730-6483	51.3922.224H	49
81.63730-6484	51.3924.223D	49
81.63730-6485	51.3923.232D	49
81.63730-6486	51.3924.224H	49
81.63730-6487	51.3923.224H	49
81.63730-6492	51.3922.233H	49
81.63730-6493	51.3923.233H	49
81.63730-6508	56.5730.127H	47
81.63730-6510	56.3931.343H	49
81.63730-6511	56.3932.343H	49
81.63730-6512	56.3931.323H	49
81.63730-6513	56.3932.323H	49
81.63730-6522	59.3941.413H	50
81.63730-6523	59.3941.423H	50
81.63730-6527	59.3894.242H	47
81.63730-6528	59.3894.241H	47
81.63730-6529	59.5800.101H	51
81.63730-6531	59.5800.201H	51
81.63730-6533	59.5800.121H	51
81.63730-6534	59.5800.221H	51
81.63730-6549	59.5800.122H	51
81.63730-6550	59.5800.222H	51
81.63730-6551	59.5800.422H	51
81.63730-6552	59.5800.322H	51
81.63730-6560	59.5800.102H	51
81.63730-6561	59.5800.202H	51
81.63730-6562	59.5800.402H	51
81.63730-6563	59.5800.302H	51
81.63730-6564	59.5800.203H	51
81.63730-6573	59.3941.413H	50
81.63730-6574	59.3941.423H	50
81.63730-6577	59.3941.544H	46
81.63730-6578	59.3941.425H	46
81.63731-0085	20.2500.110	-
81.63731-0153	58.2440.110	-
81.63731-0154	11.2440.206	-
81.63731-0157	20.2600.111H	108
81.63731-0158	20.2600.112H	108
81.63731-0165	20.2601.311	-
81.63731-0166	20.2601.312	-
81.63731-0189	21.2680.110	-
81.63731-0194	11.0018.200	-
81.63731-0199	58.2650.010	-
81.63731-0261	20.3920.510D	-
81.63731-0262	20.3920.550D	-
81.63731-0284	20.3920.750D	-
81.63731-0286		



MAN

81.63731-6470	20.2480.222	53
81.63731-6471	20.2480.221	53
81.63731-6474	20.2700.240	-
81.63731-6475	20.2700.230	-
81.63731-6476	58.2710.102	-
81.63731-6477	58.2710.401	-
81.63731-6478	20.2480.223	106
81.63731-6489	58.3801.130M	-
81.63731-6494	58.3802.310M	-
81.63731-6501	58.3801.133M	-
81.63731-6506	58.3802.315M	-
81.63731-6539	20.2710.132D	53
81.63731-6540	20.2710.142D	53, 54
81.63731-6550	61.3400.200D	-
81.63731-6557	58.3922.021H	50
81.63731-6558	58.3922.121H	-
81.63731-6559	58.3922.221D	50
81.63731-6560	58.3922.321H	50
81.63731-6566	58.3923.321M	-
81.63731-6579	58.3805.233D	-
81.63731-6584	58.3805.231D	-
81.63731-6589	58.3806.312D	-
81.63731-6611	58.3927.222D	-
81.63731-6612	58.3927.322D	-
81.63731-6613	58.3924.212D	-
81.63731-6614	58.3924.312D	-
81.63731-6617	58.3924.222M	-
81.63731-6618	58.3924.322D	-
81.63731-6619	61.3921.110D	-
81.63731-6620	61.3921.120D	-
81.63731-6621	61.3921.210D	-
81.63731-6622	61.3921.220D	-
81.63731-6638	58.5800.101H	51
81.63731-6639	58.5800.102H	51
81.63731-6640	58.5800.201H	51
81.63731-6641	58.5800.202H	51
81.63732-0014	14.3640.100	-
81.63732-0019	14.2530.100	-
81.63732-0026	14.2600.100	-
81.63732-0038	14.3650.100	-
81.63732-0040	14.3400.100	-
81.63732-0044	11.3800.300H	45
81.63732-0045	11.3810.300H	45
81.63732-0046***	51.3736.124H	44
81.63732-0047***	51.3736.126H	44
81.63732-0048***	56.3862.116H	44
81.63732-0049***	56.3861.116H	44
81.63732-0050***	56.3860.114H	44
81.63732-0051***	51.3735.126H	44
81.63732-0052	13.3800.110	-
81.63732-0054	11.3921.110H	48, 49
81.63732-0055	11.3921.120H	48, 49
81.63732-0056	11.3931.120H	48, 49
81.63732-0057	11.3931.110H	48, 49
81.63732-0058	11.3730.210H	26, 53, 54, 90, 100, 103
81.63732-0059	11.3921.110H	48, 49
81.63732-0060	11.3921.120H	48, 49
81.63732-0061	11.3931.110H	48, 49
81.63732-0062	11.3931.120H	48, 49
81.63732-0066	11.3931.120H	48, 49
81.63732-0073	20.5800.410H	51
81.63732-0074	20.5800.420H	51
81.63732-0075	20.5800.610H	51
81.63732-0076	20.5800.620H	51
81.63732-0077	11.3800.340	-
81.63732-0078	11.3810.300H	45
81.63732-0088	11.2780.910	-
81.63732-0089	61.2772.100	-
81.63732-0090	20.5800.750H	51
81.63732-0091	13.5800.100H	51
81.63733-0012	40.4485.114	99
81.63733-0015	40.2460.214H	104
81.63733-0017	40.1524.114H	-
81.63733-0019	39.2640.110	-
81.63733-0020	40.2580.222H	57
81.63733-0021	40.1524.114H	-
81.63733-0024	40.2460.600	-
81.63733-0025	40.3640.222H	40, 42
81.63733-0027	39.3120.210H	40
81.63733-0030	40.3640.222H	40, 42
81.63733-0032	40.2510.122H	40
81.63733-0036	40.3200.422H	42
81.63733-0038	40.2530.222H	36, 56, 82
81.63733-0042	40.2605.204H	41
81.63733-0045	40.2540.222H	56
81.63733-0048	40.3655.204	46
81.63733-0049	40.3650.404H	46
81.63733-0060	40.3640.222H	40, 42
81.63733-0061	40.2665.204H	43
81.63733-0064	40.3640.422H	40, 42



MAN

81.63733-0066	15.3731.070H	44
81.63733-0067	15.3731.074H	44
81.63733-0068	15.3812.110H	-
81.63733-0069	15.3812.410H	44
81.63733-0075	15.3731.074H	44
81.63733-0082	15.3921.870H	48
81.63733-0083	15.3922.870H	48
81.63733-0085	15.3931.870H	48
81.63733-0087	15.3941.870H	50
81.63733-0093	15.3801.640H	45
81.63733-0095	15.3801.840H	45
81.63733-0097	15.3811.670H	45
81.63733-0098	15.3811.870H	45
81.63733-0099	15.3946.670H	46
81.63733-0100	15.3946.870H	46
81.63733-0101	40.5725.212H	47
81.63733-0103	40.5725.212H	47
81.63733-0104	40.5735.403H	47
81.63733-0106	40.5735.403H	47
81.63733-0110	15.2771.840	52
81.63733-0111	15.2771.870	52
81.63733-0112	15.2780.870	52
81.63733-0113	15.2780.840	52
81.63733-0114	15.2561.640	53
81.63733-0115	15.2561.600	53
81.63733-6001	39.3120.410D	-
81.63733-6003	40.3640.422H	40, 42
81.63733-6005	40.2530.422H	82
81.63733-6007	40.2660.404H	43
81.63733-6011	40.2540.422H	56
81.63733-6014	39.3655.320H	-
81.63733-6027	15.2711.114	53, 90
81.63733-6028	15.2712.114	53
81.63733-6029	15.3731.470H	26, 53, 54, 90, 103
81.63733-6033	15.3921.870H	48
81.63733-6034	15.3922.870H	48
81.63733-6037	15.3931.870H	48
81.63733-6041	15.3941.670H	50
81.63733-6042	15.3941.870H	50
81.63733-6049	15.3920.840H	49
81.63733-6057	15.3932.870H	49
81.63733-6061	15.3942.650H	50
81.63733-6062	15.3942.850H	50
81.63733-6067	15.3942.650H	50
81.63733-6068	15.3942.850H	50
81.63733-6071	15.5801.840H	51
81.63733-6072	15.5811.871H	51
81.63733-6073	15.5811.871H	51
81.63733-6148	51.2500.127H	36, 82
81.97812-2350	03.0100.500	-
82.63730-0006	51.2440.217H	55
82.63730-0011	51.3801.128D	45
82.63730-0022	51.3802.128D	45
82.63730-6013	51.2500.167H	-
82.63730-6015	51.3801.148H	45
82.63730-6016	51.3802.148H	45
82.63730-6017	51.3801.168H	45
82.63730-6018	51.3802.168H	45
82.63730-6021	56.3812.128H	45
82.63730-6022	56.3812.128H	45
82.63730-6023	56.3812.148H	45
82.63730-6024	56.3812.148H	45
82.63730-6025	56.3811.168H	45
82.63730-6026	56.3812.168H	45
82.63730-6033	59.3941.515H	46
82.63730-6034	59.3652.148H	46
82.63730-6035	59.3652.168H	46
83.25402-6010	09.2000.301H	42, 43, 106
83.63700-6501	59.2712.114	53
83.63700-6502	59.2712.111	53
83.63731-6507	20.2480.216H	53, 90, 103, 106
84.63730-6016	56.2680.141	-
84.63731-0012	21.2680.110	-
84.63733-6002	40.2530.422H	82
85.20000-9609	56.2640.147	-
85.63730-6015	51.3400.147H	42
85.63730-6030	51.5720.120H	47
85.63730-6031	51.5728.120D	47
85.63730-6033	51.5720.140H	47
85.63730-6035	51.5721.160H	47
85.63730-6036	51.5722.160H	47
85.63730-6037	56.5730.120H	47
85.63730-6039	56.5730.140H	47
85.63731-6101	58.3405.260Y	47
85.63731-6102	58.3406.250H	-
85.63731-6103	58.3405.261Y	-
85.63731-6104	58.3406.252Y	-
85.63731-6105	58.3405.263Y	-
85.63731-6106	58.3406.254Y	-
85.63731-6107	58.3405.262H	-



MAN

85.63731-6108	58.3406.251H	-
85.63731-6109	58.3405.264Y	-
85.63731-6110	58.3406.253Y	-
85.63731-6121	58.3400.120Y	-
85.63731-6125	58.3400.121Y	-
85.63731-6126	58.3402.112Y	-
85.63731-6131	58.3400.122Y	-
88.25203-6024	08.3990.100	-
88.25426-6836	09.2770.220	52
88.25426-6837	09.2770.210	52
88.25427-6785	09.2560.200	53
88.25505-0024	09.3200.420H	42, 107
88.63700-6059	59.2780.120	52
88.63700-6060	59.2771.210	52
88.63700-6062	59.2770.210	52
88.63700-6063	59.2780.110	52
88.63700-6064	59.2770.110	52
88.63730-6015	51.2500.147H	36, 82
88.63730-6030	51.2530.140H	36, 56, 82
88.63730-6041	51.3400.147H	42
88.63730-6053	61.3730.324H	26
88.63730-6077	55.2561.010	53
88.63730-6078	55.2561.110	53
88.63731-6129	20.2780.631	52
88.63731-6131	20.2780.630	52
N1.01103-5714	55.2462.167	-
N1.01103-5721	55.2080.161	-
N1.01103-5797	40.2530.422H	82

Massey-Ferguson

1688 343 M 1	56.2600.127H	41
1701 674 M 1	51.1511.219H	98
1719 728 M 1	51.1522.211H	99
1891 218 M 91	51.1520.218H	98
2942 310 M 91	51.1520.218H	98
3100 963 M1	51.1522.121	-
3103 258 M1	51.2491.112H	-
3103 259 M1	51.1523.112H	-
3104 954 M 1	51.2493.127H	-
3104 955 M 1	51.2890.117H	98
3105 215 M 1	51.2890.117H	98
3301 568 M 9	51.2493.127H	-
684 552	51.1511.219H	98

MERCEDES

000 150 55 33		40, 41, 42, 55, 56, 57, 98, 106
000 159 02 68	09.2070.101H	106, 107
000 810 00 16	51.2500.127H	36, 82
000 810 01 16	51.2500.127H	36, 82
000 810 02 11	20.2810.110H	35
000 810 02 79	61.3752.147H	62, 68
000 810 03 79	61.3752.167H	62, 68
000 810 04 12	61.2703.110	-
000 810 04 16	51.2540.120H	56
000 810 04 79	61.3731.346	-
000 810 05 15	61.2703.120	-
000 810 05 25	61.3781.410H	-
000 810 05 79	61.3732.346	-
000 810 05 86	11.5890.410E	-
000 810 06 16	51.2540.130H	56
000 810 06 17	51.2500.127H	36, 82
000 810 06 25	61.3781.420H	-
000 810 06 86	11.5890.420E	-
000 810 07 16	51.2500.137H	-
000 810 08 12	20.2720.200	-
000 810 08 16	51.2500.147H	36, 82
000 810 08 79	56.3962.127H	66
000 810 09 12	20.2720.100	-
000 810 09 29	10.6211.140	56
000 810 10 25	61.3781.300	-



MERCEDES		
000 810 23 16	51.2530.140H	36, 56, 82
000 810 23 17	55.2440.245	-
000 810 23 79	51.5750.004.099	64
000 810 24 14	58.2487.711	-
000 810 24 79	51.5770.001.099	64
000 810 27 16	51.2530.120H	36, 56, 82
000 810 27 17	55.2440.250	-
000 810 28 16	56.2850.140H	57
000 810 31 17	55.3000.117H	104
000 810 33 17	55.8541.030	-
000 810 34 33	40.2580.222H	57
000 810 37 16	51.2520.147H	83
000 810 39 16	51.3200.147H	42
000 810 43 14	58.2534.190	-
000 810 45 16	56.2600.127H	41
000 810 47 16	56.2660.147H	43
000 810 48 16	51.2540.120H	56
000 810 51 33	39.1720.210H	57
000 810 52 16	51.2587.148	-
000 810 53 16	51.3200.147H	42
000 810 54 33	39.1720.410H	57
000 810 56 14	58.2534.800	-
000 810 58 16	51.3660.147	68
000 810 60 16	51.3660.167	68
000 810 62 16	51.2530.120H	36, 56, 82
000 810 63 16	51.2587.148	-
000 810 68 16	51.3400.147H	42
000 810 69 16	56.2850.130	-
000 810 70 16	56.3670.147H	59, 68
000 810 71 14	58.2534.420	-
000 810 72 14	58.2534.810	-
000 810 73 14	58.2534.820	-
000 810 80 14	58.2534.530	-
000 810 81 16	51.3660.147	68
000 810 82 16	51.3660.167	68
000 810 83 14	58.2534.340	-
000 810 83 16	51.3410.147H	42
000 810 84 16	51.2587.148	-
000 810 89 16	51.3403.148	-
000 810 90 16	56.2660.147H	43
000 810 93 14	58.2534.560	-
000 810 94 16	61.3782.167H	60
000 810 95 16	61.3782.147H	60
000 810 95 16 + 001 811 20 33	61.3780.147H	60
000 810 96 16	61.3772.147H	60, 62
000 810 96 16 + 001 811 21 33	61.3770.147H	60, 62
000 810 98 14	58.2534.540	-
000 811 00 51	61.3953.100	-
000 811 00 56	20.2720.021	-
000 811 01 44	11.5750.710	-
000 811 01 51	61.3953.200	-
000 811 01 56	20.2720.011	-
000 811 02 39	61.2530.110H	36, 56, 57, 82
000 811 02 92	11.3731.000	-
000 811 03 31	21.2710.102	-
000 811 03 61	20.3750.710	62
000 811 04 46	20.2534.050	-
000 811 04 61	20.3750.720	62
000 811 04 96	20.3790.500	61
000 811 05 35	14.2520.200	-
000 811 06 33	40.4485.114	99
000 811 06 69	11.2840.110	-
000 811 08 18	11.3491.200	-
000 811 09 14	55.2440.250	-
000 811 09 33	40.2445.122F	-
000 811 10 22	13.5890.110E	-
000 811 10 33	40.1524.115H	98, 99
000 811 11 07	11.2534.510	-
000 811 11 22	13.5890.210	-
000 811 12 07	11.2534.500	-
000 811 12 33	51.2530.120H	36, 56, 82
000 811 13 07	61.3780.100H	60, 62, 66, 68
000 811 13 33	40.2440.122H	-
000 811 15 30	51.1470.311	-
000 811 15 40	11.2534.100	-
000 811 16 23	20.3980.150F	-
000 811 18 07	20.5750.710	-
000 811 19 07	20.5750.720	-
000 811 19 33	40.2540.222H	56
000 811 19 35	14.2520.200	-
000 811 20 07	61.5750.100H	64
000 811 20 33	40.2530.222H	36, 56, 82
000 811 21 33	40.2530.222H	36, 56, 82
000 811 23 30	51.2450.227	-
000 811 23 40	20.2534.010	-
000 811 24 30	51.2430.227H	-
000 811 24 33	40.3640.222H	40, 42
000 811 24 35	14.3680.100	-



MERCEDES		
000 811 26 30	51.2450.227	-
000 811 27 40	11.2534.300	-
000 811 28 33	51.2580.120H	57
000 811 28 40	11.2534.200	-
000 811 31 33	39.3920.410H	-
000 811 32 35	14.3400.100	-
000 811 33 33	40.2530.222H	36, 56, 82
000 811 33 35	14.2530.100	-
000 811 34 33	40.2580.222H	57
000 811 35 33	40.2540.222H	56
000 811 36 33	39.3920.410H	-
000 811 36 35	14.2660.100	-
000 811 38 30	51.2450.227	-
000 811 38 33	40.2580.422H	57
000 811 39 30	51.2430.227H	-
000 811 40 30	51.2430.227H	-
000 811 43 33	39.3920.210	-
000 811 44 33	39.3415.220	-
000 811 46 30	51.2440.117H	55
000 811 47 11	11.2534.410	-
000 811 48 30	51.3490.170E	-
000 811 49 30	51.3490.172E	-
000 811 50 11	20.2534.220	-
000 811 50 30	51.3490.280E	-
000 811 51 11	20.2534.310	-
000 811 51 30	51.3490.282E	-
000 811 51 33	39.1720.210H	57
000 811 52 16	51.2587.148	-
000 811 52 30	51.3490.270E	-
000 811 53 30	51.3490.272E	-
000 811 54 30	51.3490.180E	-
000 811 54 33	39.1720.210H	57
000 811 55 30	51.3490.182E	-
000 811 56 30	51.3491.101E	-
000 811 56 33	39.1720.410H	57
000 811 57 30	51.3491.102E	-
000 811 64 33	40.2530.222H	36, 56, 82
000 811 66 33	40.3640.422H	40, 42
000 811 67 33	40.2460.214H	104
000 811 68 33	40.1525.114H	99
000 811 69 11	11.2441.210	-
000 811 69 33	15.2822.860H	58
000 811 70 33	39.4170.210H	58
000 811 70 33 + 000 821 00 29	39.4170.410H	58
000 811 71 11	20.2534.110	-
000 811 71 33	39.2089.504E	-
000 811 72 33	39.3190.210	-
000 811 76 33	40.2520.422H	83
000 811 77 33	40.3200.422H	42
000 811 83 33	39.2050.210	-
000 811 84 33	40.3680.222H	59
000 811 85 14	58.2534.000	-
000 811 85 33	40.3675.204H	59, 68
000 811 86 33	40.2695.204H	59
000 811 87 14	58.2534.130	-
000 811 88 33	40.2587.418	-
000 811 89 33	39.3188.504	58
000 811 90 33	39.1720.210H	57
000 811 91 33	40.3665.118F	68
000 811 93 33	40.3640.422H	40, 42
000 811 94 33	39.1720.410H	57
000 811 99 33	40.2587.118	-
000 813 04 36	14.5890.100	-
000 813 05 36	14.5890.200	-
000 820 12 77	08.5890.100	71, 95
000 820 27 13	09.5750.001.099	64
000 820 28 13	09.5750.220.099	64
000 820 50 98	10.0862.007	-
000 820 51 98	10.0862.002	-
000 820 57 08	08.5890.012E	-
000 821 00 29	10.2820.410E	58
000 821 01 29	10.3681.400	59
000 821 02 29	10.3670.410H	59, 68
000 821 03 29	10.6121.140	56, 68, 82
000 821 04 29	10.3670.410H	59, 68
000 821 05 29****	10.6121.140	56, 68, 82
000 821 08 29	10.6221.140	56
000 821 09 29	10.6211.140	56
000 821 10 29	10.0862.003	-
000 821 11 29	10.6421.140	57
000 821 29 25	08.2530.200	-
000 987 18 37	20.2710.200H	53, 54, 90, 91, 103
001 810 00 19	61.5891.131E	-
001 810 01 19	61.5892.131E	-
001 810 02 19	61.5893.131E	-
001 810 03 19	61.5891.231E	-
001 810 04 19	61.5892.231E	-
001 810 05 19	61.5893.231E	-
001 810 06 19	61.5891.331E	-



MERCEDES		
001 810 07 19	61.5892.331E	-
001 810 08 14	58.2534.610	-
001 810 08 19	61.5893.331E	-
001 810 09 19	61.5891.431E	-
001 810 10 19	61.5892.431E	-
001 810 11 19	61.5893.431E	-
001 810 12 19	61.5891.133E	-
001 810 13 19	61.5892.133E	-
001 810 14 19	61.5893.133E	-
001 810 15 19	61.5891.233E	-
001 810 16 14	58.2534.410	-
001 810 16 19	61.5892.233E	-
001 810 17 16	51.3731.321	-
001 810 17 19	61.5893.233E	-
001 810 18 19	61.5891.333E	-
001 810 19 14	58.2534.460	-
001 810 19 19	61.5892.333E	-
001 810 20 14	58.2487.511	-
001 810 20 19	61.5893.333E	-
001 810 21 14	58.2484.812	-
001 810 21 19	61.5891.433E	-
001 810 22 19	61.5892.433E	-
001 810 23 14	58.2484.912	-
001 810 23 19	61.5893.433E	-
001 810 24 14	58.2487.711	-
001 810 25 14	58.2534.020	-
001 810 26 14	58.2534.150	-
001 810 30 14	58.2487.721	-
001 810 36 16	61.2700.403	-
001 810 37 16	61.2700.402	-
001 810 38 16	61.2700.401	-
001 810 39 16	61.3730.324H	26
001 810 41 14	58.2484.922	-
001 810 42 14	58.2534.350	-
001 810 43 14	58.2534.550	-
001 810 44 14	58.3781.100H	61
001 810 45 14	58.3781.200H	61
001 810 46 14	58.3781.400E	-
001 810 47 14	58.3781.300	-
001 810 60 16	15.2711.114	53, 90
001 810 61 16	15.2712.114	53
001 810 66 14	58.3781.100E	54
001 810 67 14	58.3781.204	-
001 810 68 14	58.3781.304E	-
001 810 69 14	58.3781.404E	-
001 810 69 16	51.3732.346H	-
001 810 70 16	51.3732.326H	53, 54, 90, 103
001 810 71 16	51.3731.346	-
001 810 72 16	51.3731.326	53, 54, 90, 103
001 810 85 14	58.3782.300E	-
001 810 86 14	58.3782.200E	-
001 810 87 14	58.3782.100E	-
001 810 88 14	58.3782.400E	-
001 810 90 16	61.3783.147H	60
001 810 91 16	61.3783.167H	60
001 810 92 16	-	-
+ 000 811 13 07	61.3773.147H	60, 62
001 810 93 14	58.5751.100E	-
001 810 94 14	58.5751.200E	-
001 810 95 14	58.5751.300E	-
001 810 96 14	58.5751.400E	-
001 810 97 14	58.5752.100H	64
001 810 98 14	58.5752.200H	64
001 810 99 14	58.5752.300H	64
001 811 00 22	13.5890.120	71, 73, 95, 97
001 811 00 33	40.2665.204H	43
001 811 01 22	13.5890.220	71, 73, 95, 97
001 811 03 33	40.2585.018E	-
001 811 04 33	15.3491.372H	70, 93
001 811 05 33	15.3491.371H	70, 93
001 811 06 33	15.3491.071H	70, 93
001 811 07 33	15.3491.072H	70, 93
001 811 14 33	40.2660.	

OE

MEKRA



MERCEDES

001 811 62 14	58.3499.212	-
001 811 65 14	58.3494.312	-
001 811 66 14	58.3494.412	-
001 811 69 33	15.3961.174H	66
001 811 70 33	39.3558.518	-
001 811 72 33	15.3492.301	-
001 811 73 33	15.3752.470H	62, 68
001 811 77 33	39.1720.210H	57
001 811 78 33	39.2088.504	58
001 811 79 33	39.1720.410H	57
001 811 80 33	39.2089.504E	-
001 811 81 33	40.3675.204H	59, 68
001 811 82 33	40.2491.222H	-
001 811 84 33	40.2580.222H	57
001 811 85 33	39.4170.210H	58
001 811 85 33		
+ 000 821 00 29	39.4170.410H	58
001 811 86 33	40.3680.222H	59
001 811 87 33	40.2530.222H	36, 56, 82
001 811 88 33	39.3920.210	-
001 811 89 33	39.3188.504	58
001 811 90 33	40.2540.222H	56
001 811 91 33	39.2918.512	-
001 811 99 33	15.5750.840H	64
001 820 80 21	61.3990.100	-
001 821 00 29	10.6221.100	98
001 822 89 20	08.5891.110	71, 95
001 822 90 20	08.5891.120	71, 95
001 822 91 20	08.5891.130	71, 95
001 822 92 20	08.5891.140	71, 95
001 822 93 20	08.5891.111	71, 95
001 822 94 20	08.5891.141	71, 95
002 810 00 14	58.5752.400E	64
002 810 08 14	58.3783.300H	61
002 810 08 16	59.5790.110H	61, 65
002 810 09 14	58.3783.200H	61
002 810 12 14	58.3783.140	-
002 810 15 14	58.5754.130	-
002 810 54 14	58.5750.012.099	64
002 810 56 14	58.5750.015.099	64
002 810 59 14	58.5750.013.099	64
002 810 64 14	58.5750.005.099	64
002 810 66 14	58.5750.006.099	64
002 811 00 33	15.5770.870H	64
002 811 03 33	15.3791.470H	61, 63, 65
002 811 04 33	15.3780.840H	60
002 811 11 33	15.5891.701E	-
002 811 12 33	15.5891.702E	-
002 811 13 33	15.5892.701E	-
002 811 14 33	15.5892.702E	-
002 811 15 33	15.5891.741H	71, 95
002 811 16 33	15.5891.742H	71, 95
002 811 17 33	15.5892.741E	-
002 811 18 33	15.5892.742E	-
002 811 19 33	15.5891.611H	71, 95
002 811 20 33	15.5891.612H	71, 95
002 811 21 33	40.3605.403H	61
002 811 22 33	15.5791.470H	61, 65
002 811 24 33	15.5891.751E	-
002 811 25 33	15.5891.752E	-
002 811 26 33	15.5892.751E	-
002 811 27 33	15.5892.752E	-
002 811 33 33	19.1012.002.099	67
002 811 34 33	19.1012.003.099	67
002 811 37 33	19.1012.000.099	67
002 811 38 33	19.1012.001.099	67
002 811 46 33	19.5750.011.099	64
002 811 47 33	19.5770.311.099	64
002 811 52 33	19.5890.011.099	73
002 811 53 33	19.5890.012.099	73
003 545 10 07	08.3200.233H	91, 107
003 820 99 15	09.3491.100	-
004 820 11 42	08.3200.325	-
004 820 47 15	09.3200.360	-
004 820 83 42	08.3200.324	-
005 820 28 42	08.3491.312	-
005 820 63 42	61.3780.124	-
006 820 53 42	08.3498.324	-
008 820 65 10	08.2415.250	105
281 810 71 16	51.2530.120H	36, 56, 82
281 810 73 16	51.2530.140H	36, 56, 82
301 810 00 17	55.2440.260	-
301 810 20 16	51.2530.128H	-
301 810 21 16	51.2530.140H	36, 56, 82
301 811 00 20	55.2440.230	-
305 810 25 16	51.2462.217H	-
314 810 13 16	51.2540.120H	56
314 810 19 16	51.2540.130H	56
314 810 20 16	51.2540.140H	56
314 810 25 16	56.2441.117H	55
314 810 26 16	51.2530.120H	36, 56, 82

OE

MEKRA



MERCEDES

314 811 00 14	11.2440.120H	55
314 811 00 30	51.2440.217H	55
314 811 01 30	51.2440.217H	55
314 811 01 33	51.2440.117H	55
314 811 03 30	51.2440.117H	55
319 811 00 30	40.1510.122H	98
319 811 03 30	51.1512.211H	-
321 811 02 33	40.1524.115H	98, 99
321 811 06 30	51.1520.218H	98
321 811 07 30	51.1520.218H	98
322 811 00 30	51.1531.115H	99
322 811 03 14	11.2440.130H	55
322 811 17 14	11.2440.027	-
329 811 00 30	51.1531.115H	99
337 811 50 14	11.2440.130H	55
350 246 90 02	51.1512.211H	-
350 246 90 03	51.1520.215	-
350 246 90 04	40.1524.115H	98, 99
356 810 04 14	58.2534.210	-
356 810 05 14	58.2534.280	-
356 810 06 11	20.2480.213	-
356 810 06 14	58.2534.240	-
356 810 09 14	58.2534.425	-
356 810 12 14	58.2534.200	-
356 810 14 14	58.2534.225	-
356 810 16 14	58.2534.250	-
356 810 18 14	58.2534.260	-
356 810 19 14	58.2534.230	-
356 810 20 14	58.2534.270	-
356 810 23 14	58.2534.320	-
356 810 24 14	58.2534.300	-
356 810 24 16	59.2700.401	-
356 810 25 14	58.2534.290	-
356 810 26 14	58.2534.330	-
356 810 26 16	59.2700.402	-
356 810 27 16	59.2700.403	-
356 810 30 16		
356 810 31 16	15.3731.470H	26, 53, 54, 90, 103
356 810 32 16	15.3731.490	-
356 811 04 71	59.2701.000	-
357 810 09 19	11.3730.210H	26, 53, 54, 90, 100, 103
357 810 10 19	59.2700.001	-
357 810 20 93	59.2700.002	-
357 810 24 13	59.3402.102	-
357 810 34 13	58.2474.332	-
357 810 36 13	58.2487.421	-
357 810 36 16	58.2534.840	-
357 810 42 93	59.2534.540	-
357 810 43 93	59.3403.300	-
357 810 52 93	59.3403.422	-
357 810 55 93	59.3403.438	-
357 810 58 13	59.3403.404	-
357 810 66 14	58.2474.330	-
357 810 67 14	58.2487.411	-
357 810 75 16	58.2484.612	110
357 810 76 16	59.3403.411	-
357 810 83 14	59.3403.412	-
357 810 85 14	58.2534.400	-
357 810 86 14	58.2534.830	-
357 810 87 14	58.2534.580	-
357 810 88 14	58.2534.490	-
357 810 89 14	58.2481.224H	-
357 810 90 14	58.2485.225H	-
371 810 02 16	58.2534.780	-
371 810 18 16	56.2660.127H	43
381 810 08 14	51.3410.147H	42
381 810 25 16	21.3683.110	-
381 810 26 16	51.2530.120H	36, 56, 82
381 810 29 16	51.2530.140H	36, 56, 82
381 810 37 16	51.2530.130H	-
381 810 38 16	51.2580.120H	57
381 810 39 16	51.2580.140H	57
381 810 40 16	51.2580.160H	57
381 810 71 16	51.2580.130	-
381 810 72 16	51.2530.120H	36, 56, 82
381 810 72 16	51.2530.130H	-
381 811 06 36	56.2441.217	-
381 811 11 36	56.2441.217	-
406 810 04 16	51.1522.211H	99
406 810 52 16	51.1522.211H	99
406 810 56 16	51.1522.310	-
406 811 00 30	40.1510.122H	98
414 810 00 17	55.5570.120H	-
416 810 00 16	51.1522.211H	99
416 810 04 16	51.1523.111H	-
460 810 01 16	51.2491.121H	55
460 810 03 16	51.2491.121H	55
601 810 01 16	51.2491.122H	55
601 810 02 14	58.2494.011	-
601 810 02 16	51.2491.121H	55

OE

MEKRA



MERCEDES

601 810 03 14	58.2494.012	-
601 810 04 14	58.2495.011	-
601 810 05 14	58.2495.012	-
601 810 06 14	20.2495.213	-
601 810 07 16	20.2495.223	-
601 810 09 16	51.2493.131H	55
601 810 21 14	58.2495.212	-
601 810 22 16	51.2493.131H	55
601 810 24 14	58.2494.211	-
601 810 25 14	58.2494.212	-
601 811 00 14	20.2492.213	-
601 811 00 33	40.2495.114	-
601 811 00 51	20.2492.110	-
601 811 01 14	20.2492.223	-
601 811 01 33	40.2491.322	-
603 811 00 30	51.2490.221	-
603 811 00 33	40.2495.214F	-
608 811 01 33	40.2495.114	-
611 810 00 16	51.2493.111H	-
611 810 01 16	51.2493.121H	55
611 810 04 14	58.2493.111	-
611 810 06 14	58.2493.121	-
611 811 00 33	40.2491.122H	-
611 811 01 33	40.2491.222H	-
611 811 04 14	20.2493.310	-
611 811 05 14	20.2493.410	-
612 810 01 66	51.2493.121H	55
613 810 11 16	59.2720.401	-
613 810 12 14	58.2534.850	-
613 810 13 16	59.2720.402	-
613 810 22 16	59.2720.407	-
613 810 23 16	59.2720.405	-
627 810 M1 47	58.2704.048	111
629 810 04 16	59.3951.300	-
629 810 52 16	59.3954.402	-
629 811 00 33	15.3951.174	69
629 811 01 33	15.3951.114	69
629 811 02 33	15.3952.174	-
629 820 01 42	61.3950.324	-
641 810 00 16	11.3680.910G	-
641 810 00 16	51.2820.120H	58
641 810 01 16	51.2820.140H	58
641 810 02 16	51.2822.160H	58
641 810 11 14	58.3680.310G	-
641 810 12 14	58.3680.410G	-
641 810 13 14	58.3680.510G	-
641 810 20 16	56.2830.120H	58
641 810 21 16	56.2830.140H	58
641 810 22 16	59.2840.120H	58
641 810 40 16	59.2840.120H	58
641 810 42 16	51.3680.147H	59
641 810 44 16	51.3680.167H	59
641 810 46 16	56.3670.147H	59, 68
641 810 47 16	59.2690.127H	59
641 810 63 16	59.2690.127H	59
641 810 68 16	51.3680.147H	59
641 811 01 31	20.2840.110	58
641 811 04 14	11.3610.310	58
641 811 05 07	11.3680.910G	-
641 811 05 39	11.2841.230H	58
641 811 07 39	11.2840.230H	58
641 811 10 39	11.3680.400	-
649 810 12 14	58.3681.110G	-
649 810 14 14	58.3680.110G	-
649 811 02 39	11.2842.230G	-
663 810 08 16	51.2530.120H	36, 56, 82



MERCEDES

673 810 42 16	51.2530.140H	36, 56, 82
673 810 43 16	51.2580.160H	57
673 810 46 16***	56.2850.120H	57
673 810 47 16	56.2850.140H	57
673 810 48 16	59.2693.127H	59
673 810 49 16	59.2693.127H	59
673 811 00 39	11.2843.230G	-
8.688.075.000.0	61.2800.401H	69
8.688.075.001.0	15.2800.480H	69
8.688.075.002.0	15.2800.470H	69
8.688.075.163.0	11.2800.011	69
8.688.075.165.0	20.2800.550	69
8.688.075.169.0	08.2810.124	69
8.688.076.000.0	61.2800.402H	69
8.688.076.164.0	11.2800.012	69
8.688.076.166.0	20.2800.650	69
901 810 01 16	51.3490.110H	70
901 810 02 16	51.3490.120H	70
901 810 03 16	51.3490.210H	-
901 810 04 12	61.3490.120	-
901 810 04 16	51.3490.220H	-
901 810 09 16	51.3490.112H	70
901 810 10 16	51.3490.122H	70
901 810 10 93	56.3491.110H	70
901 810 11 93	56.3492.110H	70
901 810 13 16	61.3493.110	-
901 810 14 16	61.3493.120	-
901 810 16 93	51.3490.510	-
901 810 18 93	59.3499.112H	-
901 810 21 16	61.3493.112	-
901 810 22 16	61.3493.122	-
901 810 25 16	59.3491.110H	70
901 810 26 16	59.3491.120H	70
901 810 37 16	59.3492.110H	70
901 810 38 16	59.3492.120H	70
901 810 45 16	59.3492.112H	-
901 810 46 16	59.3492.122H	-
901 810 51 16	59.3491.112	-
901 810 55 16	51.3490.110H	70
901 810 57 16	51.3490.112H	70
901 810 58 16	59.3491.110H	70
901 810 60 16	59.3491.112	-
901 810 61 16	59.3492.110H	70
901 810 63 16	59.3492.112H	-
901 810 64 16	51.3490.120H	70
901 810 66 16	51.3490.122H	70
901 810 67 16	59.3491.120H	70
901 810 69 16	59.3491.122H	-
901 810 70 16	59.3492.120H	70
901 810 72 16	59.3492.122H	-
901 810 73 16	51.3490.210H	-
901 810 75 16	51.3490.212A	-
901 810 76 16	59.3491.210	-
901 810 78 16	59.3491.212	-
901 810 79 16	59.3492.210	-
901 810 81 16	59.3492.212H	-
901 810 82 16	51.3490.220H	-
901 810 84 16	51.3490.222A	-
901 810 85 16	59.3491.220	-
901 810 87 16	59.3491.222	-
901 810 88 16	58.3492.220	-
901 810 90 16	59.3492.222H	-
901 811 03 07	11.3490.421	-
906 810 18 93	51.5891.111.199	72, 96
906 810 19 93	51.5891.211.199	72, 96
906 810 20 93	51.5891.411.199	72, 96
906 810 21 93	51.5891.311.199	72, 96
906 810 22 93	51.5892.111.199	72, 96
906 810 23 93	51.5892.211.199	72, 96
906 810 24 93	51.5892.411.199	72, 96
906 810 25 93	51.5892.311.199	72, 96
906 810 26 93	51.5893.111.199	72, 96
906 810 27 93	51.5893.211.199	72, 96
906 810 28 93	51.5893.411.199	72, 96
906 810 29 93	51.5893.311.199	72, 96
906 810 30 93	51.5891.112.199	72, 96
906 810 31 93	51.5891.212.199	72, 96
906 810 32 93	51.5891.412.199	72, 96
906 810 33 93	51.5891.312.199	72, 96
906 810 34 93	51.5892.112.199	72, 96
906 810 35 93	51.5892.212.199	72, 96
906 810 36 93	51.5892.412.199	72, 96
906 810 37 93	51.5892.312.199	72, 96
906 810 38 93	51.5893.112.199	72, 96
906 810 39 93	51.5893.212.199	72, 96
906 810 40 93	51.5893.412.199	72, 96
906 810 41 93	51.5893.312.199	72, 96
906 810 48 16	51.5891.111H	71, 95
906 810 49 16	51.5891.211H	71, 95
906 810 50 16	51.5891.411H	71, 95
906 810 51 16	51.5891.311H	71, 95



MERCEDES

906 810 52 16	51.5892.111H	71, 95
906 810 53 16	51.5892.211H	71, 95
906 810 54 16	51.5892.411H	71, 95
906 810 55 16	51.5892.311H	71, 95
906 810 56 16	51.5893.111H	71, 95
906 810 57 16	51.5893.211H	71, 95
906 810 58 16	51.5893.411H	71, 95
906 810 59 16	51.5893.311H	71, 95
906 810 60 16	51.5891.113H	71, 95
906 810 61 16	51.5892.113H	71, 95
906 810 62 16	51.5891.413H	71, 95
906 810 63 16	51.5891.313H	71, 95
906 810 64 16	51.5892.113H	71, 95
906 810 65 16	51.5892.213H	71, 95
906 810 66 16	51.5892.413H	71, 95
906 810 67 16	51.5892.313H	71, 95
906 810 68 16	51.5893.113H	71, 95
906 810 69 16	51.5893.213H	71, 95
906 810 70 16	51.5893.413H	71, 95
906 810 71 16	51.5893.313H	71, 95
940 810 26 16	59.3793.127H	61, 63, 65
940 810 55 16	59.3964.210H	66
940 810 56 16	59.3964.310H	66
941 810 07 16	59.3781.223	-
941 810 08 16	59.3781.111	-
941 810 09 16	59.3781.113	-
941 810 10 16	59.3792.127H	61, 63, 65
941 810 12 16	59.3781.323	-
941 810 13 16	59.3781.411	-
941 810 14 16	59.3781.413	-
941 810 21 16	59.3792.127H	61, 63, 65
941 810 27 16	59.3781.125	-
941 811 00 07	20.3780.700H	61
943 810 25 16	59.3963.210	-
943 810 47 16	59.3965.210H	66
943 810 48 16	59.3965.310H	66
957 810 00 16	59.3602.128H	61, 85
957 810 26 16	59.3604.178H	61, 85
957 811 00 33	40.3605.204	61, 85
973 810 01 14	58.3751.100E	-
973 810 02 14	58.3751.200E	-
973 810 03 14	58.3752.100	62
973 810 04 14	58.3752.200	62
973 810 05 14	58.3751.300E	-
973 810 06 14	58.3751.400E	-
973 810 07 14	58.3752.300E	62
973 810 08 14	58.3752.400E	62
973 810 14 16	59.3751.111	-
973 810 15 16	59.3751.211	-
973 810 16 16	59.3751.113	-
973 810 19 16	59.3751.411	-
973 810 20 16	59.3751.313	-
973 810 21 16	59.3751.413	-
973 810 22 16	59.3751.222	-
973 810 23 16	59.3751.223	-
973 810 25 16	59.3751.323	-
973 810 26 16	59.3752.111	-
973 810 28 16	59.3752.113	-
973 810 29 16	59.3752.213	-
973 810 31 16	59.3752.411	-
973 810 32 16	59.3752.313	-
973 810 33 16	59.3752.413	-
973 810 35 16	59.3752.223	-
973 810 37 16	59.3752.323	-
973 810 68 16	59.3971.210	-
973 810 69 16	59.3971.310	-
973 810 73 16	59.3962.210H	66
973 810 74 16	59.3961.310H	66
B 66 5603 16	55.5570.120H	-
B 66 5603 97	56.3491.110H	70
B 66 5603 98	56.3492.110H	70

Neoplan

1905 001 00	51.3640.127H	40
1905 011 00	58.2500.220H	-
1905 017 00	51.2580.120H	57
1905 518 00	51.2530.140H	36, 56, 82
1905 520 00	58.2601.010	109
1905 530 00	51.2530.140H	36, 56, 82
1905 530 08	40.2530.422H	82
1905 561 00	51.3400.147H	42
1905 563 00	51.3400.147H	42
1905 564 00	09.3400.420	107
N1.00187.2000	51.2500.137H	-
N1.01103-5730	55.3000.117H	104
N1.01103-5829	51.2500.167H	-
N1.01107-5175	59.2762.101	-
N1.01107-5177	59.2718.112	-
N1.01108-2502	59.2762.201	-

New Holland → Case New Holland



O & K(Orenstein & Koppel) → Faun

RENAULT

50.00.244.768	09.3200.410H	107
50.00.289.373	40.2875.404H	79
50.00.289.377	15.2860.880H	79
50.00.295.475	15.4700.270H	-
50.00.296.871	56.2870.120H	-
50.00.630.074	40.3200.422H	42
50.01.824.148	51.4700.111H	-
50.01.833.026	61.3480.149H	27, 78
50.01.838.475	51.2860.112H	79
50.01.842.202	51.2860.212H	79
50.01.851.897	08.2810.124	69
50.01.851.898	08.2810.224	-
50.01.853.679	61.3480.149H	27, 78
50.01.853.719	11.2810.310	-
50.01.853.720	11.2810.300	-
50.01.856.290	51.4700.113H	-
50.01.856.292	61.3480.149H	27, 78
50.01.856.614	15.4700.470H	-
50.01.873.670	51.2860.001.099	79
50.01.873.671	51.2860.002.099	79
50.01.873.672	56.2870.140H	79
50.01.873.673	56.2870.130H	79
50.10.057.322	51.3200.147H	42
50.10.093.515	15.4700.470H	-
50.10.578.503	59.3900.123H	76
50.10.578.504	59.3900.223H	77
50.10.578.505	59.3901.123H	76
50.10.578.506	59.3901.223H	77
50.10.578.511	59.5580.247H	30, 74, 76, 86
50.10.578.512	59.5580.147H	30, 74, 76, 86
50.10.578.517	20.5580.110H	30, 74, 76, 86
50.10.578.518	20.5580.120H	31, 75, 77, 87
50.10.623.057	20.3900.510	30, 74, 76, 86
50.10.623.058	20.3900.520H	31, 75, 77, 87
50.10.623.225	59.3900.142H	30, 74, 86
50.10.623.226	59.3900.242H	31, 75, 87
50.10.623.230	59.3900.248	-
50.10.623.231	59.3901.143H	74
50.10.623.232	59.3901.243H	75
50.10.623.240	59.3900.132H	30, 74, 86
50.10.623.241	59.3900.232H	31, 75, 87
50.10.623.246	59.3901.133H	74
50.10.623.247	59.3901.233H	75
50.10.623.689	59.3901.143H	74
50.10.623.690	59.3901.243H	75
50.10.623.697	59.3901.133H	74
50.10.623.698	59.3901.233H	75
50.10.646.159	59.2880.130H	79
74.20.781.811	20.5580.140F	30, 31, 75, 77, 87
74.20.781.812	20.5580.130H	30, 74, 76, 86
74.20.812.551	59.3901.142H	74
74.20.812.555	59.3901.242H	75
74.20.812.580	59.3901.232H	75
74.20.812.581	59.3901.132H	74
74.20.849.799	59.5524.748.099	79
74.20.849.835	59.5524.649.099	77
74.20.849.837	59.5524.648.099	31, 77
74.20.849.852	59.5524.640.099	77
74.20.850.409	20.5520.250	79
74.20.862.779	11.3900.200H	30, 31, 74, 75, 86, 87</



RENAULT

74.20.913.815	61.3900.120H	31, 75, 77
74.20.914.884	58.3900.343H	30, 74, 76, 86
74.20.914.885	58.3900.443H	31, 75, 77, 87
74.20.914.886	58.3900.349E	-
74.20.914.887	58.3900.449E	-
74.20.914.934	58.3900.333H	30, 74, 86
74.20.914.938	58.3900.433H	31, 75, 87
74.21.020.285	51.5524.930H	77, 79, 81
74.21.276.373	61.3482.149H	27, 78
74.21.346.867	20.5520.250	79
74.82.226.023	59.5524.640.099	77
74.82.226.025	59.5524.648.099	31, 77
74.82.226.027	59.5524.649.099	77
74.82.265.705	59.5524.748.099	79
74.85.120.820	61.3900.120H	31, 75, 77
	59.5524.730.099	79

SCANIA

010 2088	55.3000.117H	104
010 8832	11.3001.100	104, 109
110 6403	56.1561.110H	80, 83
110 6734	11.1560.200	80
110 6950	51.2576.127H	80
110 6953	51.2576.127H	80
110 6955	51.2576.147H	80
134 6377	15.4001.110H	81
134 6378	15.4002.110H	81
134 6382**	15.4002.114H	81
134 6579	15.4002.114H	81
139 6501**	15.4002.110H	81
139 6503**	15.4002.110H	81
139 6512**	15.4002.110H	81
139 6514**	15.4002.110H	81
144 1525	59.2706.131	-
144 1529	59.2706.121	-
144 1530	59.2706.101	-
144 1531	59.2706.134	-
144 1533	59.2706.124	-
144 1534	59.2706.104H	-
144 2705	15.4002.110H	81
144 2706	15.4001.110H	81
144 3864	15.4002.114H	81
144 8217	20.2480.210H	106
145 1226	20.2480.216H	53, 90, 103, 106
145 1227	20.2480.211	106
148 4037	59.5501.111	-
148 4038	59.5501.211	-
148 4041	59.5502.111	-
148 4042	59.5502.211	-
148 4076	59.5520.030H	81
148 4077	58.5524.010	-
148 4078	58.5524.020	81
148 4079	58.5524.021	81
148 4081	20.5520.440	-
148 5116	59.2706.223	-
148 5119	59.2706.222	-
148 5120	59.2706.202	-
150 4678	59.5520.040H	81
150 5200	15.3731.370	-
150 5201	15.3731.470H	26, 53, 54, 90, 103
150 5202	11.3730.210H	26, 53, 54, 90, 100, 103
150 5203	61.2708.842H	111
152 2367	09.3200.360	-
152 2368	09.2000.300	-
152 2881	59.5524.032H	81
154 3451	51.2510.127H	40
172 3518	59.4002.300H	-
172 3519	59.4002.400H	-
173 2776	15.4002.110H	81
173 2778	15.4002.114H	81
173 2782**	15.4002.114H	81
173 2783**	15.4002.114H	81
174 2422	09.3200.310H	106, 107
174 5558	58.5524.011	-
175 526	51.2590.117H	80
175 7155	59.5520.030H	81
175 9703	08.3200.233H	91, 107
176 297	40.2590.114H	80, 93
176 3444	51.1524.117	-
176 5808	56.4001.140H	-
176 5809	56.4000.140H	-
176 5985	15.4001.840H	81
176 7265	15.4001.740H	81
180 5203	51.3732.326H	53, 54, 90, 103
191 2467	59.5520.040H	81
236 315	51.2550.127H	82
236 317	40.2550.222H	82
256 646	51.2590.117H	80
266 795	51.2550.147H	-



SCANIA

296 171***	56.1561.116H	-
296 171	56.1561.110H	80, 83
+ 396 433	40.1561.104	-
296 459	40.2570.222H	80
296 538	40.2570.222H	80
296 538	40.2570.222H	80
+ 376 243	40.2570.222H	80
316 143	56.1561.116H	80
316 620	20.1560.122H	80
316 623	51.2576.127H	80
316 624	51.2576.147H	80
316 640	58.2230.100	-
316 918	40.1561.105H	80, 83
316 920	56.1561.110H	80, 83
+ 396 433	51.2576.147H	80
356 495	51.2576.147H	80
367 624	10.6421.120	-
376 243	61.1561.100H	80
396 848	11.2570.100	80
396 856	51.2530.140H	36, 56, 82
415 035	58.2471.012H	-
424 892	58.2471.111H	-
433 901	51.2540.140H	56
437 489	51.1524.127	-
437 490	58.2471.014H	-
444 226	51.3400.147H	42
455 390	51.2590.117H	80
561 119	55.2080.261	-
630 968	40.2530.222H	36, 56, 82
639 092	40.2540.422H	56
639 140	40.1525.114H	99
639 153	15.4601.164H	-
931 909 70		

Setra

8.688.000.083.0	58.2534.360	-
8.688.000.084.0	58.2534.370	-
8.688.000.090.0	58.2534.371	-
8.688.000.098.0	58.2534.440	-
8.688.000.099.0	58.2534.390	-
8.688.000.142.0	58.2534.470	-
8.688.000.143.0	58.2534.475	-
8.688.000.149.0	58.2534.480	-
8.688.000.154.0	58.2534.430	-
8.688.000.177.0	59.2801.300	-
8.688.000.302.0	40.2580.422H	57
8.688.000.305.0	09.2000.301H	42, 43, 106
8.688.032.013.0	10.6321.100	-
8.688.041.000.0	51.2500.147H	36, 82
8.688.041.001.0	40.2500.222H	36, 82
8.688.041.029.0	10.6121.100	-
8.688.048.001.0	40.2530.222H	36, 56, 82
8.688.050.001.0	39.2900.110	-
8.688.051.003.0	51.2540.140H	56
8.688.052.001.0	40.2585.218E	-
8.688.053.003.0	51.2580.160H	57
8.688.053.101.0	40.2585.018E	-
8.688.055.003.0	51.2580.140H	57
8.688.055.101.0	40.2580.222H	57
8.688.059.001.0	39.1720.410H	57
8.688.062.210.0	39.1060.003	-
8.688.062.212.0	39.2630.700	-
8.688.075.167.0	20.2800.510	-
8.688.075.171.0	08.2800.100	-
8.688.075.172.0	20.2800.710	-
8.688.075.191.0	09.2800.200	-
8.688.075.197.0	20.2801.110	-
8.688.075.202.0	11.2800.110	-
8.688.076.168.0	20.2800.610	-
8.688.076.173.0	20.2800.810	-
8.688.076.198.0	20.2801.210	-
8.688.076.203.0	11.2800.210	-
8.688.076.208.0	20.2800.410	-
8.688.087.000.0	59.2810.331	-
8.688.087.220.0	15.2810.480H	35
8.688.090.000.0	59.2810.431	-
8.688.090.214.0	11.2810.200H	35
8.688.090.221.0	15.2816.490	-
8.688.090.222.0	15.2810.470H	35
8.688.090.225.0	20.2810.310	-
8.688.090.226.0	20.2810.210	-
8.688.090.227.0	11.2810.300	-
8.688.090.228.0	11.2810.310	-
8.688.091.000.0	59.2810.333	-
8.688.092.000.0	59.2810.433	-
8.688.092.001.0	59.2811.433	-
8.688.093.000.0	59.2810.441	-
8.688.094.000.0	59.2810.443	-
8.688.095.000.0	56.2600.147H	-
8.688.095.229.0	40.2600.404H	-
8.748.009.001.0	40.2085.214F	-



Setra

8.748.017.100.0	51.2431.120	-
8.748.018.100.0	51.2510.127H	40
8.748.021.000.0	51.2431.110	-
8.748.022.000.0	55.2082.127	-
8.748.032.200.0	51.2431.100	-
8.748.033.000.0	51.2461.117H	-
8.848.018.100.0	51.2510.127H	40
8.868.041.000.0	51.2500.147H	36, 82
8.919.940.437.4	56.3860.114H	44
8.919.959.721.4	40.2540.422H	56
8.919.964.241.4	09.3200.310H	106, 107
8.933.462.000.0	51.3640.127H	40
814-6710100-130C	51.2520.147H	83

Solaris

1905 500 010	58.2704.068	-
1905 500 020	58.2704.096	-
1905 501 000	58.2704.065	-
1905 501 020	58.2704.090	-
1905 506 000	58.2704.086H	-
1905 506 010	58.2704.093H	-
1905 508 000	58.2704.048	111
1905 508 010	58.2704.094	-
1905 509 000	58.2704.070H	-
1905 509 010	58.2704.095	-

Steyr

152 0077 0056	51.2530.120H	36, 56, 82
152 0077 0057	51.2530.140H	36, 56, 82
161 0077 0009	09.2070.101H	40, 41, 42, 55, 56, 57, 98, 106
161 0077 0011	51.3200.147H	42
161 0077 0012	51.3100.147H	42
161 0077 0099	56.2441.117H	55
161 0077 0103	51.2890.117H	98
161 0077 0704	08.3200.233H	91, 107
161 0077 0705	40.3200.422H	42
161 0077 0712	40.2500.422H	36, 82
161 0077 2020	51.3410.127H	42
161 0077 2021	51.3400.147H	42
161 0077 2022	56.2640.127H	36
161 0077 2023	59.2640.110H	36
161 0077 2024	51.3410.147H	42
161 0077 2026	56.2640.147	-
161.00.77.0015	09.3200.410H	107
161.00.77.2027	09.3400.420	107
34 777 002	40.2510.222H	40
58 999 005 7800	51.3410.147H	42
58 999 005 7810	51.3400.147H	42
58 999 005 7960	51.2540.140H	56
58 999 005 79601	40.2540.422H	56
721 183 106 0	51.2491.121H	55
85.0000-1002	10.6121.140	56, 68, 82

Terex → Demag

Van Hool

660 152 740	51.3400.147H	42
-------------	--------------	----

VOLVO

1096 643	59.3601.128H	85
1100 7006	51.2550.127H	82
1116 4488	55.2200.100H	-
1130 5984	51.1520.212H	99
1195 934	51.2520.147H	83
1199 4438	40.2550.222H	82
1251 2005	59.2710.401H	90, 103
1251 2010	59.2710.402H	90, 103
1251 2040	11.3730.210H	26, 53, 54, 90, 100, 103
1502 309	40.2550.122H	-
1510 330	59.2710.402H	90, 103
1572 146	51.2550.147H	-
1581 550	51.2500.127H	36, 82
1581 551	51.2500.137H	-
1581 597	14.2500.100	-
1581 599	40.2500.222H	36, 82
1581 602	40.2500.422H	36, 82
1581 616	51.2500.147H	36, 82
1582 522	40.2685.204H	40, 41
1584 635	11.2500.410	-
1594 410	51.2500.137H	-
1594 411	51.2500.147H	36, 82
1594 412	51.2500.147H	36, 82
1594 413	40.2500.322	-
1594 415	40.2500.422H	36, 82
1594 902	51.2520.147H	83
1599 034	51.2550.147H	-
1599 462		



VOLVO		
1618 769	56.2610.147H	83
1618 973	56.2610.127H	83
1621 353	51.2520.147H	83
1621 354	56.2610.147H	83
1622 446	56.1561.110H	80, 83
1696 931	14.2520.200	-
1697 007	40.2520.222H	83
1697 008	40.2520.422H	83
1697 497	40.2525.600F	-
1697 679	40.1561.105H	80, 83
1697 862	40.2615.204	83
1697 863	14.2540.100	-
1697 926	40.2530.222H	36, 56, 82
1697 926		
+ 3090 006	40.2530.422H	82
1697 927	14.2530.100	-
1697 928	61.2530.110H	36, 56, 57, 82
1697 930	39.3021.110	-
1697 932	39.1781.210	-
1697 984	40.2615.204	83
1699 011*	39.3730.410H	27, 33, 89
1699 012*	39.1900.210	27, 33, 89
1699 013*	39.1900.410H	27, 33, 89
1699 014	39.3730.210H	27, 33, 89
1699 015	39.3730.410H	27, 33, 89
1699 016	39.1900.210	27, 33, 89
1699 017	39.1900.410H	27, 33, 89
1699 919*	39.3730.210H	27, 33, 89
1905 50200	51.3732.326H	53, 54, 90, 103
1905 50300	51.3731.326	53, 54, 90, 103
2020 7881	59.3900.143H	30, 74, 86
2036 0811	20.2240.002.099	88
2045 5981	14.2240.002.099	88
2045 5982	14.2240.001.099	88
2045 5986	15.2240.865H	-
2045 5995	15.2241.810H	-
2050 5851	58.2705.008	111
2050 5863	58.2705.007P	111
2050 5864	58.2705.009	111
2051 5454	20.2480.223	106
2051 5456	09.5000.300	-
2052 3873	59.2710.402H	90, 103
2052 3877	59.2710.401H	90, 103
2052 6353	56.2660.127H	43
2054 0638	20.2710.500	-
2056 7633	59.2242.301.099	88
2056 7633		
+ 2045 5982		
+ 2074 640	59.2242.300H	88
2056 7635		
+ 2045 5981		
+ 2074 640	59.2242.400H	88
2056 7670	15.2240.840H	88
2056 7685	15.2241.810H	-
2058 9788	15.2240.865H	-
2070 7812	59.5580.247H	30, 74, 76, 86
2070 7813	20.5580.110H	30, 74, 76, 86
2070 7814	59.5580.147H	30, 74, 76, 86
2070 7815	20.5580.120H	31, 75, 77, 87
2070 7874	59.3900.133H	30, 74, 86
2070 7876	59.3900.132H	30, 74, 86
2070 7881	59.3900.143H	30, 74, 86
2070 7885	59.3900.142H	30, 74, 86
2070 8110	20.3900.510	30, 74, 76, 86
2070 8230	20.3900.520H	31, 75, 77, 87
2070 8293	59.3900.242H	31, 75, 87
2070 8303	59.3900.233H	31, 75, 87
2071 4488	56.2600.127H	41
2071 6739	56.2240.001.099	88
2074 3983	59.3900.243H	31, 75, 87
2074 6401	20.2240.001.099	88
2075 4076	15.3731.370	-
2076 0960	59.3900.232H	31, 75, 87
2076 7635	59.2242.401.099	88
2078 1811	20.5580.140F	30, 31, 75, 77, 87
2078 1812	20.5580.130H	30, 74, 76, 86
2084 1078	56.2241.141.099	88
2084 1078		
+ 2036 0811		
+ 2107 076	56.2241.140H	88
2084 1081	56.2240.141.099	88
2084 1081		
+ 2036 0811		
+ 2107 076	56.2240.140H	88
2085 4088	20.2480.211	106
2085 4555	15.3702.170H	84
2085 4560	15.3703.871	-
2085 4564	15.3702.470H	84, 91
2085 4568	15.3712.410H	84
2085 4576	40.2520.222H	83
2085 4621	56.2610.127H	83
2085 4626	56.2610.147H	83
2085 4637	56.2666.148	-



VOLVO		
2086 2779		
2086 2782	11.3900.200H	30, 31, 74, 75, 86, 87
2086 2795	61.3900.100H	30, 31, 74, 75, 86, 87
2086 2800	15.3900.840H	30, 31, 74, 75, 76, 77, 86, 87
2086 2809	11.3910.200H	30, 74, 86
2086 2810	61.3911.110H	30, 74, 86
2086 2812	15.3911.871H	31, 75, 77, 87
2086 2813	08.5751.324E	31, 75, 87
2086 2815	61.3911.120H	31, 75, 87
2086 2815	15.3911.872H	31, 75, 87
2086 6665	61.3900.110H	30, 74, 76, 86
2086 6672	08.5751.424E	30, 74, 76, 86
2090 3722	59.3900.143H	30, 74, 86
2090 3723	58.3900.133H	30, 74, 86
2090 3727	58.3900.143H	30, 74, 76, 86
2090 3732	58.3900.233H	31, 75, 87
2091 4884	58.3900.343H	30, 74, 76, 86
2091 4885	58.3900.443H	31, 75, 77, 87
2091 4886	58.3900.349E	-
2091 4887	58.3900.449E	-
2091 4934	58.3900.333H	30, 74, 86
2091 4938	58.3900.433H	31, 75, 87
2092 5244	08.3200.233H	91, 107
2093 6169	08.2240.002.099	88
2093 6170	08.2240.001.099	88
2096 5441	13.3730.310	-
2107 0768	15.2242.870H	88
2115 1129		
+ 2071 6956	59.2240.002.099	88
2115 1132		
+ 2071 6956	59.2240.001.099	88
2120 3311	15.3712.870H	84
2120 3313	59.3601.178H	85
2132 0365	15.2242.870H	88
2132 0383	15.2240.840H	88
2132 6524	59.3900.242H	31, 75, 87
2802 032	51.2491.121H	55
3090 006	10.6121.140	56, 68, 82
3090 010	10.6221.120	-
3090 011****	10.6121.160	89
3090 389	56.2660.127H	43
3090 390	56.2660.147H	43
3090 391	40.2665.204H	43
3090 392	14.2660.100	-
3090 395	51.2520.127H	83
3090 396	51.2520.147H	83
3090 734	40.3605.204	61, 85
3090 735	14.3600.100	-
3090 736	15.3702.170H	84
3090 737	15.3702.470H	84, 91
3090 738	15.3712.110H	84
3090 739	15.3712.410H	84
3090 823	40.3640.422H	40, 42
3090 824	14.3400.100	-
3090 825	08.3400.324	-
3090 849	58.2541.203	-
3090 850	58.2541.213	-
3091 256	61.3700.231H	84
3091 257	61.3700.241H	84
3091 258	61.3710.231H	84
3091 259	61.3710.241H	84
3091 261	61.3710.221	-
3091 750	58.3701.130H	84
3091 751	58.3701.140H	84
3091 756	15.3702.470H	84, 91
3091 757	15.3712.410H	84
3092 040	08.3700.326H	84
3092 854	15.3702.470H	84, 91
3093 518	40.2660.404H	43
3093 519	40.2520.422H	83
3098 468	51.3400.147H	42
3098 469	40.2530.422H	82
3098 470	40.3640.422H	40, 42
3098 471	58.2474.010	-
3098 472	58.2474.116	-
3099 643	21.3701.201	-
3126 117	59.3602.128H	61, 85
3127 674	08.3200.220	-
3520 26	51.2550.127H	82
3525 07	40.2550.222H	82
3570 244	51.1520.218H	98
3980 922	59.3702.031	-
3980 923	59.3702.041	-
3980 924	59.3702.231H	84
3980 925	59.3702.241H	84
3980 926	59.3702.431H	84
3980 927	59.3702.441H	-
3980 930	59.3712.031	-
3980 931	59.3712.041	-



VOLVO		
3980 932	59.3712.231H	-
3980 933	59.3712.241H	84
3980 934	59.3712.431H	-
3980 935	59.3712.441H	-
3980 943	59.3702.011	-
3980 944	59.3702.021	-
3980 945	59.3702.211	-
3980 946	59.3702.221	-
3980 947	59.3702.411	-
3980 948	59.3702.421	-
3980 950	59.3712.011	-
3980 951	59.3712.021	-
3980 952	59.3712.211	-
3980 953	59.3712.221	-
3980 954	59.3712.421	-
3980 955	59.3712.421	-
4057 536	51.3640.127H	40
53-707127-731326	51.3731.326	53, 54, 90, 103
53-707127-732346	51.3732.326H	53, 54, 90, 103
53-707213-010524		26, 53, 54, 90, 100, 103
53-707213-480217	11.3730.210H	100, 103
53-707213-710111	20.2480.217H	90, 103, 106
53-707213-710200	20.2710.111H	53, 90, 91, 103
	20.2710.200H	53, 54, 90, 91, 103
53-707213-710401	59.2710.401H	90, 103
53-707213-710402	59.2710.402H	90, 103
53-750610-208091	20.2480.216H	53, 90, 103, 106
6793 879	51.2530.120H	36, 56, 82
6793 880	51.2530.140H	36, 56, 82
6793 881	56.1561.119H	-
7030 3998	56.3773.147	-
7030 9620	58.2705.001	111
7030 9621	58.2705.002	111
7030 9623	51.3731.321	-
7030 9625	51.3731.324	-
7030 9627	51.3731.326	53, 54, 90, 103
7030 9628	51.3732.326H	53, 54, 90, 103
7030 9630	58.2704.059	-
7031 0107	56.2630.127H	-
7031 0110	11.1523.212	36, 109
7031 0152	08.3200.233H	91, 107
7031 0198	58.2474.340H	-
7032 3681	51.3732.321	-
7032 3682	51.3732.324	-
7032 3683	58.2704.071	-
7032 8278	59.2710.401H	90, 103
7032 8283	59.2710.402H	90, 103
7032 8289	59.2710.406	103
7032 8291	59.2706.104H	-
7032 8298	58.2704.048	111
7033 1011	58.2704.114	53, 90
7033 1060	58.2704.044	111
7033 1061	55.3000.117H	104
7033 1062	51.1524.117	-
7033 1063	51.2500.167H	-
7033 1117	15.3731.490	-
7033 1119	20.2700.240	-
7033 1120	20.2700.230	-
7033 1121	20.2710.121	53, 90, 91, 103
7033 1122	20.2710.111H	53, 90, 91, 103
7033 1123	20.2480.217H	90, 103, 106
7033 1124	20.2480.216H	53, 90, 103, 106
7033 1940	59.2762.322	-
7033 1941		54, 69, 91, 103, 106
7033 2172	20.2710.620	-
7034 8002	58.2704.078	-
7034 8006	20.2480.216H	53, 90, 103, 106
		53, 54, 90, 91, 103
7035 2000	20.2710.200H	103
7035 2646	58.2705.003	111
7036 0528	20.2480.210H	106
7036 0530	20.2710.132D	53
		53, 54, 90, 91, 103
7036 0533	20.2710.200H	103
		26, 53, 54, 90, 100, 103
7036 0534	11.3730.210H	100, 103
7036 0538	20.2710.142D	53, 54
7036 0539	08.3492.324	-
7036 0540	59.2710.401H	90, 103

OE

MEKRA



VOLVO

8350 046555		26, 53, 54, 90, 100, 103
8350 046970	11.3730.210H	53, 90, 91, 103
8350 046971	20.2710.111H	53, 90, 103, 106
8350 055819	20.2480.216H	-
8706 2719 00017	59.2762.322	53, 54, 90, 91, 103
8706 2719 00018	20.2710.200H	90, 103, 106
8706 2719 00019	20.2480.217H	53, 90, 91, 103
8706 2719 00020	20.2710.121	53, 90, 91, 103
8706 2719 00021	20.2710.111H	91
8706 2719 00025	09.3200.220	53, 54, 90, 103
8706 2719 000525	51.3732.326H	26, 53, 54, 90, 100, 103
8706 2719 00059	11.3730.210H	53, 54, 90, 103
8706 2719 00060	51.3731.326	53, 54, 90, 103
	51.3732.326H	61, 85
VG 10035 001	51.3731.326	53, 54, 90, 103
VG 10035 002	51.3732.326H	53, 54, 90, 103

VW

2E1 857 501 AJ	51.5891.111.199	72, 96
251 857 513	53.1981.177H	92
251 857 513 A	53.1981.127H	92
251 857 514	53.1982.177H	92
251 857 514 A	53.1982.127H	92
281 857 547	51.2440.117H	55
283 857 514	53.1942.127H	-
2D0 857 521	15.3491.071H	70, 93
2D0 857 521 A	15.3491.371H	70, 93
2D0 857 522	15.3491.072H	70, 93
2D0 857 522 A	15.3491.372H	70, 93
2D0 857 537 C 01C	11.3491.200	-
2D1 857 501 A 01C	51.3495.110H	93
2D1 857 501 C 01C	51.3495.112H	93
2D1 857 502 A 01C	51.3495.120H	93
2D1 857 502 C 01C	51.3495.122H	93
2D2 857 501 A 01C	51.3495.210V	-
2D2 857 501 C 01C	51.3495.212H	-
2D2 857 502 A 01C	51.3495.220V	-
2D2 857 502 C 01C	51.3495.222H	-
2D3 857 501 D 01C	59.3496.110V	-
2D3 857 501 E 01C	59.3496.112V	-
2D3 857 501 F 01C	59.3497.110V	-
2D3 857 501 G 01C	59.3497.112V	-
2D3 857 502 D 01C	59.3496.120V	-
2D3 857 502 E 01C	59.3496.122V	-
2D3 857 502 F 01C	59.3497.120V	-
2D3 857 502 G 01C	59.3497.122V	-
2D4 857 502 G 01C	59.3497.122V	-
2D4 857 502 D 01C	59.3496.220V	-
2D4 857 502 E 01C	59.3496.222V	-
2D4 857 502 F 01C	59.3497.220V	-
2D4 857 502 G 01C	59.3497.222V	-
2E0 857 527	13.5890.120	71, 73, 95, 97
2E0 857 528	13.5890.220	71, 73, 95, 97
2E0 941 293 D	08.5890.012E	-
2E0 945 981	08.5890.100	71, 95
2E0 953 049 A	08.5891.110	71, 95
2E0 953 049 B	08.5891.130	71, 95
2E0 953 049 C	08.5891.111	71, 95
2E0 953 050 A	08.5891.120	71, 95
2E0 953 050 B	08.5891.140	71, 95
2E0 953 050 C	08.5891.141	71, 95
2E1 857 501 AN	51.5892.112.199	72, 96
2E1 857 136	14.5890.100	-
2E1 857 136 A	14.5890.200	-
2E1 857 501 AK	51.5892.111.199	72, 96
2E1 857 501 AL	51.5893.111.199	72, 96
2E1 857 501 AM	51.5891.112.199	72, 96
2E1 857 501 E	51.5891.111H	71, 95
2E1 857 501 F	51.5891.113H	71, 95
2E1 857 502 AK	51.5891.211.199	72, 96
2E1 857 502 AL	51.5892.211.199	72, 96
2E1 857 502 AM	51.5893.211.199	72, 96
2E1 857 502 AN	51.5892.212.199	72, 96
2E1 857 502 AP	51.5893.112.199	72, 96
2E1 857 502 BE	51.5891.212.199	72, 96
2E1 857 502 E	51.5891.211H	71, 95
2E1 857 502 F	51.5891.213H	71, 95
2E1 857 516 A	13.5890.110E	-
2E1 857 516 B	13.5890.210	-
2E1 857 587	15.5891.741H	71, 95
2E1 857 587 A	15.5891.611H	71, 95
2E1 857 587 D	15.5892.741E	-
2E1 857 588	15.5891.742H	71, 95
2E1 857 588 A	15.5891.612H	71, 95
2E1 857 588 D	15.5892.742E	-

OE

MEKRA



VW

2E2 857 501 C	51.5891.311H	71, 95
2E2 857 501 D	51.5891.313H	71, 95
2E2 857 501 N	51.5891.311.199	72, 96
2E2 857 501 P	51.5891.312.199	72, 96
2E2 857 501 Q	51.5892.312.199	72, 96
2E2 857 501 R	51.5893.312.199	72, 96
2E2 857 502 C	51.5891.411H	71, 95
2E2 857 502 D	51.5891.413H	71, 95
2E2 857 502 N	51.5891.411.199	72, 96
2E2 857 502 Q	51.5891.412.199	72, 96
2E2 857 502 R	51.5892.412.199	72, 96
2E2 857 502 S	51.5893.412.199	72, 96
2E3 857 501 C	51.5892.111H	71, 95
2E3 857 501 E	51.5893.111H	71, 95
2E3 857 501 F	51.5892.113H	71, 95
2E3 857 501 G	51.5893.113H	71, 95
2E3 857 502 D	51.5892.211H	71, 95
2E3 857 502 E	51.5893.211H	71, 95
2E3 857 502 F	51.5892.213H	71, 95
2E3 857 502 G	51.5893.213H	71, 95
2E4 857 501 AD	51.5892.311.199	72, 96
2E4 857 501 AE	51.5893.311.199	72, 96
2E4 857 501 D	51.5892.311H	71, 95
2E4 857 501 E	51.5893.311H	71, 95
2E4 857 501 F	51.5892.313H	71, 95
2E4 857 501 G	51.5893.313H	71, 95
2E4 857 502 AE	51.5893.411.199	72, 96
2E4 857 502 E	51.5892.411H	71, 95
2E4 857 502 F	51.5893.411H	71, 95
2E4 857 502 G	51.5892.413H	71, 95
2E4 857 502 H	51.5893.413H	71, 95
2K1 857 501 AC	51.9220.110H	94
2K1 857 501 AE	51.9221.110H	94
2K1 857 502 AF	51.9220.220H	94
2K1 857 502 AG	51.9221.220H	94
2K1 857 507 9B9		
+ 7E1 858 553 9B	51.9220.110H	94
2K1 857 507 C 9B9		
+ 7E1 858 553	51.9221.110H	94
2K1 857 508 9B9		
+ 7E1 858 554 9B	51.9220.220H	94
2K1 857 508 C 9B9		
+ 7E1 858 554	51.9221.220H	94
701 857 507 F 01C		
701 857 507 F 01C	61.1960.161	-
+ 701 857 521	53.1960.161H	92
701 857 507 H	61.1960.163	-
701 857 507 H		
+ 701 857 521 B	53.1961.113H	92
701 857 508 F 01C	61.1961.161	-
701 857 508 F 01C		
+ 701 857 522	53.1961.161H	92
701 857 508 H	61.1961.163	-
701 857 508 H		
+ 701 857 522 G	53.1962.123H	92
701 857 513 A	15.1964.100H	92
701 857 521 B	15.1964.100H	92
701 857 521 H	15.1962.151H	92
701 857 521 J	15.1962.100H	92
701 857 521 K	15.1963.151H	-
701 857 522 G	15.1964.152H	92
701 857 522 J	15.1962.200H	-
701 857 522 L	15.1962.152H	92
702 857 507 F 01C	61.1962.161	-
702 857 508 F 01C	61.1963.161	-
7E1 857 507 9B9		
+ 7E1 858 553 9B	51.9230.110H	94
7E1 857 508 9B9		
+ 7E1 858 554 9B	51.9230.220H	94
7E1 857 522	15.9220.220H	94
7E1 857 522 A	15.9221.220H	94
7H1 857 507 A 9B9		
+ 7E1 858 553	51.9231.110H	94
7H1 857 508 A 9B9		
+ 7E1 858 554	51.9231.220H	94
7H1 857 521	15.9220.110H	94
7H1 857 521 A	15.9221.110H	94
	40.2590.114H	80, 93

- * Original-Nr. bedeutet: **Komplettspiegel**, wir liefern nur das **Ersatzglas**.
- * OEM-no. signifies **complete mirror**; we supply only the **replacement glass**.
- * réf. constructeur signifie **le rétroviseur complet**, nous fournissons seulement **la glace de rechange**.
- * N° original significa **espelho completo**; apenas repomos a **vidro**
- * N. OE: **specchio completo**; per l'aftermarket forniamo solo il **vetro di ricambio**.
- * N° original significa **el espejo completo**, sólo suministramos **el cristal de repuesto**.
- * OEM nummer innebär : **komplett spegel**, endast **reservglas** tillgängligt.
- * Originální číslo znamená: **kompletní zrcadlo**, dodává se jen **náhradní sklo**.
- * оригинальный номер обозначает: **зеркало в комплекте**, но поставляется только **запасное стекло**.
- ** OEM no. **komple aynayı ifade ediyor**; aftermarket için sadece **aynacamini** tedarik edebiliriz.
- ** Original-Nr. bedeutet: **Komplettspiegel**; für den freien Handel nur **Glaseinheit** lieferbar.
- ** OEM-no. signifies: **complete mirror**; for the aftermarket we supply only the **glassunit**.
- ** réf. constructeur signifie **le rétroviseur complet**, nous fournissons seulement **la glace sur support plastique**.
- ** N° original significa **espelho completo**; no mercado de reposição vendemos apenas a **unidade de vidro**.
- ** N. OE: **specchio completo**; per l'aftermarket forniamo solo il **vetro**.
- ** N° original significa **el espejo completo**, sólo suministramos **la unidad de cristal**.
- ** OEM nummer innebär : **komplett spegel**, enbart **glaseinheit** för eftermarknad.
- ** Originální číslo znamená: **kompletní zrcadlo**, pro volný obchod se dodává jen **náhradní sklo**.
- ** оригинальный номер обозначает: **зеркало в комплекте**, для свободной продажи поставляется только **стекло**, наклеенное на пластмассовую пластинку.
- ** OEM no. **komple aynayı ifade ediyor**; aftermarket için sadece **plastik muhafazalı ayna camını** tedarik edebiliriz.
- *** Originalnr. bedeutet: Spiegelkopf **ohne Glaseinheit**; wir liefern: **Komplettspiegel incl. Glaseinheit**.
- *** OEM-no. signifies: **mirrorhead without glassunit**; we supply: **complete mirror incl. glassunit**.
- *** référence constructeur signifie: **rétroviseur sans glace sur support plastique**; nous fournissons le **rétroviseur complet**.
- *** N° original significa **cabeça de espelho sem unidade de vidro**; no mercado de reposição vendemos apenas a **unidade de vidro**.
- *** N. OE: **specchio senza vetro**; forniamo lo **specchio completo**.
- *** N° original significa: **retrovisor sin unidad de cristal**; suministramos el **retrovisor completo**.
- *** OEM nummer innebär: **spiegelhuvud utan glaseinheit**, Vi levererar **komplett spegel inklusive glaseinheit**.
- *** Originální číslo znamená: **zrcadlo bez skla s deskou**, dodáváme **kompletní zrcadlo včetně skla s deskou**.
- *** оригинальный номер обозначает: **головка зеркала без стекла**, наклеенного на пластмассовую пластинку, поставляется нами **зеркало в комплекте включая** стекло, наклеенное на пластинку.
- *** OEM no. **camsız ayna gövdesini ifade ediyor** cam dahil olmak üzere **komple aynayı** tedarik edebiliriz.
- **** unser Artikel ist nicht identisch mit der Original-Nr., stellt aber eine gute Alternative dar.
- **** our item is not identical to the OEM-no. but is a practical alternative.
- **** notre article n'est pas identique à la réf. constructeur, mais signifie une bonne alternative.
- **** nosso produto não é idêntico ao número original, mas é uma alternativa intercambiável.
- **** il nostro prodotto non è identico all'originale, ma è intercambiabile.
- **** nuestro producto no está idéntica al número original, pero significa una buena alternativa.
- **** Våra artiklar är ej identiska med originalet men ett bra alternativ.
- **** náš výrobek není identický s originálním výrobkem, je ale dobrou náhradou.
- **** оригинальный номер обозначает: наш продукт не идентичен с оригиналом, но является хорошей альтернативой ему.
- **** ürünümüz OEM ürünüyle özdeş değil sadece elverişli bir alternatiftir.



DAF

65 CF, 75 CF,
85 CF, 95 XF
alternativ 75, 85,
03/00 - 04/06
95 09/92



373	II e1 02★0423 II (E1) 010423			Ø 28 mm
------------	---------------------------------	--	--	---------

MEKRA	Beschreibung description description descripção descripcion benamning Popis описаније özellik					OE
	Part Number	Icons	Dimensions	OE Part Number		
61.3730.324H		384 x 205 x 120	1425 104 ÷ 1610 186			
15.3731.470H		368 x 189 x 40	1425 109 ÷ 1610 190			
11.3730.210H		367 x 187 x 60	1425 113			
61.3730.326H		384 x 205 x 120	1425 105 ÷ 1610 184			
15.3731.470H		368 x 189 x 40	1425 109 ÷ 1610 190			
11.3730.210H		367 x 187 x 60	1425 113			

65 CF, 75 CF,
85 CF, 95 XF
alternativ 75, 85, 95
03/00 - 04/06
09/92



386	IV e1 02★0424 IV (E1) 010424 IV e1 03★0023			Ø 28 mm
------------	--	--	--	---------

MEKRA	Beschreibung description description descripção descripcion benamning Popis описаније özellik					OE
	Part Number	Icons	Dimensions	OE Part Number		
61.3860.214H		219 x 170 x 120	1425 108 ÷ 1610 187			
61.3865.224		219 x 170 x 120				
15.3861.114H		203 x 154 x 36	1425 111 ÷ 1610 191			
11.3860.500H		203 x 154 x 60	1425 114			
61.3865.124H		219 x 170 x 120	1610 189			
61.3865.234		219 x 170 x 120				
15.3862.174H		203 x 154 x 36				
11.3860.500H		203 x 154 x 60	1425 114			

65 CF, 75 CF,
85 CF, 95 XF
alternativ 75 / 85 / 95
03/00
09/92





906	IV e1 03★0014			Ø 28 mm
------------	---------------	--	--	---------

MEKRA	Beschreibung description description descripção descripcion benamning Popis описаније özellik					OE
	Part Number	Icons	Dimensions	OE Part Number		
61.9065.114H		209 x 218 x 136	1670 877			
15.9060.870H		204 x 195 x 58	1670 878			
11.9060.100H		202 x 194 x 55	1670 888			
56.9065.110		189 x 136				
15.9060.870H		204 x 195 x 58	1670 878			
61.3860.100		210				
11.9060.100H		202 x 194 x 55	1670 888			

DAF

348    **Ø 22 mm**



 *Beschreibung description descripción descripción descripción Benämning Põpsis описание озаглав*  **OE**

1	61.3481.149H		395 x 205 x 145	1805 714
	15.3480.840H		372 x 189 x 2	1805 717
2	61.3480.149H		382 x 193 x 85	1405 295 + 180 5712 1404 871





03/00 - 05/06

LF 45/55

348 **IV e1 03★0185**   **Ø 22 mm**
IV E1 021023



 *Beschreibung description descripción descripción descripción Benämning Põpsis описание озаглав*  **OE**

61.3482.149H		199 x 199 x 97	1796 324 + 1404 868 1405 350
40.3485.403E		191 x 191 x 3	1796 325 + 1404 849

FA 1700 - FA 3300 1987
75 / 85 / 95 09/92 - 02/00





 *Beschreibung description descripción descripción descripción Benämning Põpsis описание озаглав*  **OE**

39.3730.210H		373 x 190 x 3	0699 956 + 0589 436 0699 856
39.3730.410H		373 x 190 x 3	0699 857 + 1305 462 0589 435 + 1305 462
10.6121.160		340 x 159	





 *Beschreibung description descripción descripción descripción Benämning Põpsis описание озаглав*  **OE**

39.1900.210		193 x 156 x 3	0699 853 + 0589 438
39.1900.410H		193 x 156 x 3	0699 854 + 0589 437
10.6321.160		186 x 130	



DAF

XF 95, XF 105 / XC 01/2006
CF 05/2006

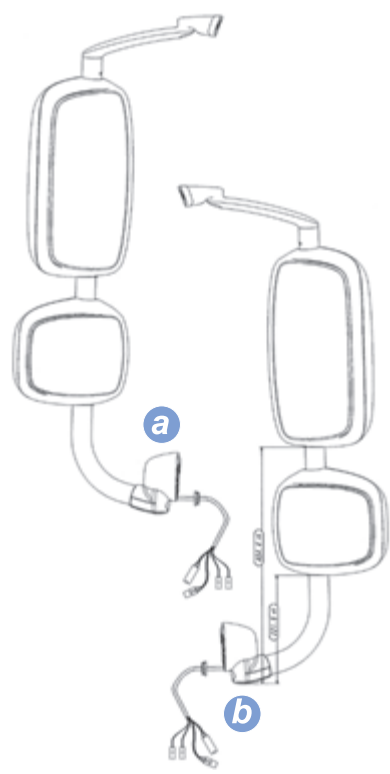

570 II e1 03★0007 Ø 40 mm

MEKRA	Beschreibung description description description benamning описание özellik					OE
	61.5700.210H	15.5701.840H	11.5700.100H			
					411 x 228 x 140	1692 557
					363 x 177 x 15	1685 330
					411 x 228 x 110	1644 325
					411 x 228 x 140	1812 862 * (1689 348)
					363 x 177 x 15	1685 330
					411 x 228 x 110	1644 325
					250	

570 Ø 40 mm

MEKRA	Beschreibung description description description benamning описание özellik					OE
	XF	CF				
					818 x 40 ø	1685 324
					818 x 40 ø	1685 325
					818 x 40 ø	1685 326
					818 x 40 ø	1685 327
					920 x 40 ø	1788 972
					920 x 40 ø	1788 973
					920 x 40 ø	1788 487
					920 x 40 ø	1788 488
					920 x 40 ø	1788 974
					920 x 40 ø	1788 975
					920 x 40 ø	1788 485
					920 x 40 ø	1788 486
			a		145 x 98 x 68	1644 324
			b		145 x 98 x 68	1644 323

571 IV e1 03★0008 Ø 40 mm

MEKRA	Beschreibung description description description benamning описание özellik					OE
	61.5710.210H	15.5711.870H	11.5710.110H			
					239 x 221 x 140	1692 556
					207 x 161 x 15	1685 331
					239 x 221 x 118	1644 326
					239 x 221 x 140	1817 860 * 1812 862 (1689 347)
					207 x 161 x 15	1685 331
					239 x 221 x 118	1644 326
					250	

DAF

552	V E1 02★0742			
	V VI E1 03★0033			
	V VI (E1) 020894			

	Beschreibung description description descripção descripción benamning popis описаније özellik		

XF 105/XC
CF

XF	59.5520.230H					319 x 187 x 50	1669 573
	59.5520.240H					319 x 187 x 50	1614 022
CF	59.5520.130H					319 x 187 x 50	
	59.5520.140H					319 x 187 x 50	1614 021



552	V VI E1 03★0033			INTEGR.
	V VI (E1) 020894			

	Beschreibung description description descripção descripción benamning popis описаније özellik		

XF 1	59.5525.235H						321 x 405 x 431	1684 042
	59.5525.236H						321 x 405 x 431	1684 043
XC	59.5525.331H						256 x 340 x 1037	1684 046
	59.5525.332H						256 x 340 x 1037	1684 047
CF 2	59.5525.131H						419 x 453 x 466	1684 030
	59.5525.132H						419 x 453 x 466	1684 031
	59.5525.133H						419 x 343 x 466	1684 032
	59.5525.134H						419 x 343 x 466	1684 033
CF 3	59.5525.135H						336 x 492 x 466	1684 034
	59.5525.136H						336 x 492 x 466	1684 035
	20.5521.100						110 x 51	1698 180

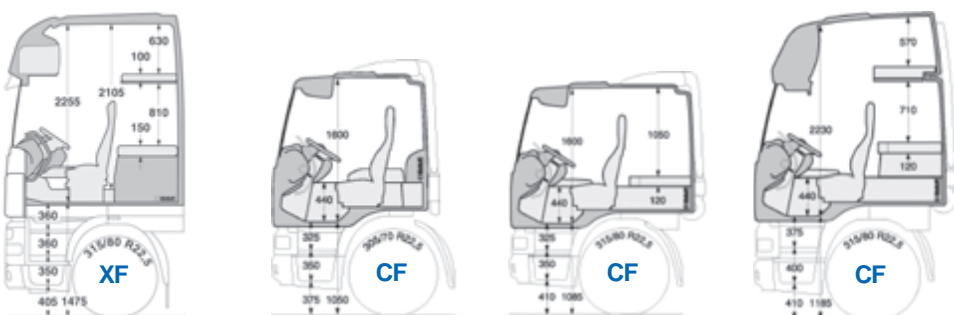

1 Super Space Cab 2 Day Cab 2 Sleeper Cab 3 Space Cab

Für Fahrzeuge ...
for vehicles ...
pour véhicules ...
para vehículos ...
per veicoli ...
para vehículos ...
för fordon ...
pro vozidla ...
для транспортных средств ...
 için...

a mit Sonnenblende
with sunvisor
avec pare-soleil
com Quebra-Sol
con aletta parasole
con visera antideslumbrante.
med solskydd
se sluneční clonou
с солнцезащитным козырьком
güneşlikli araçlar

b ohne Sonnenblende
without sunvisor
sans pare-soleil
sem Quebra-Sol
senza aletta parasole
sin visera antideslumbrante
utan solskydd
bez sluneční clony
без солнцезащитного козырька
güneşsiz araçlar

reflecting your visions.



DAF

390	II E1 03★0009	II E1 020914			INTEGR.
	IV E1 03★0037	IV E1 020916			

	Beschreibung description descripción descrizione descripción بەرنامنىڭ описание özalik		
--	---	--	--

1	59.3900.142H		880 x 340 x 155	1700 961
	59.3900.143H		880 x 340 x 155	1700 303
2	59.3900.132H		880 x 440 x 155	1700 304
	59.3900.133H		880 x 440 x 155	1700 265
	61.3900.100H		370 x 245 x 105	1735 521
	61.3900.110H		370 x 245 x 105	1735 519
	61.3911.110H		230 x 245 x 105	1735 522
	15.3900.840H		337 x 202	1737 933
	15.3911.871H		197 x 200	1736 879
	08.5751.424E		130	1736 892
	11.3900.200H		370 x 247 x 80	1736 884
	11.3910.200H		244 x 225 x 75	1736 883
1	58.3900.143H		800 x 270 x 28 ø	1733 892
	58.3900.343H		800 x 270 x 28 ø	1733 888
2	58.3900.133H		800 x 350 x 28 ø	1736 954 ÷ 1736 854
	58.3900.333H		800 x 350 x 28 ø	1736 952 ÷ 1736 852
	20.3900.510		518 x 98	1736 924
	20.5580.110H		293 x 76	1736 920
	20.5580.130H		293 x 76	1736 918

05/2006

DAFLF

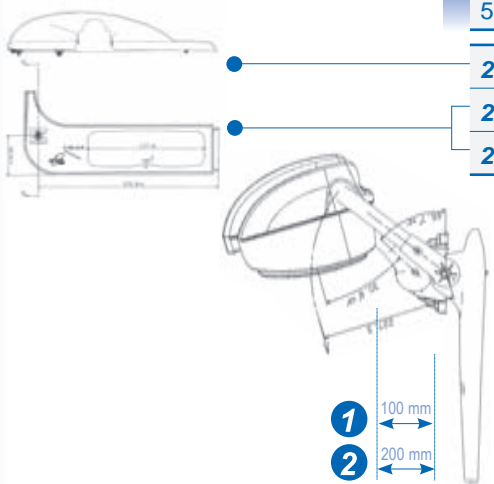

558	V E1 03★0011			
	V E1 020912			

	Beschreibung description descripción descrizione descripción بەرنامنىڭ описание özalik		
--	---	--	--

	59.5580.147H		260 x 229 x 70	1409 570 ÷ 1401 046
	59.5580.247H		260 x 229 x 70	1409 962
	20.5580.140F		293 x 76	1736 917

05/2006

DAF

390	II 03★0009	II 020914			INTEGR.
	IV 03★0037	IV 020916			

	Beschreibung description descripción description descripción Benämning Põppis ožetnik		

1	59.3900.242H		880 x 340 x 155	1700 963
	59.3900.243H		880 x 340 x 155	1700 306
2	59.3900.232H		880 x 440 x 155	1700 307
	59.3900.233H		880 x 440 x 155	1700 269
	61.3900.100H		370 x 245 x 105	1735 521
	61.3900.120H		370 x 245 x 105	1735 520
	61.3911.120H		230 x 245 x 105	1735 523
	15.3900.840H		337 x 202	1737 933
	15.3911.872H		197 x 200	1736 865
	08.5751.324E		130	1736 891
	11.3900.200H		370 x 247 x 80	1736 884
	11.3910.200H		244 x 225 x 75	1736 883
1	58.3900.243H		800 x 270 x 28 ø	1733 893
	58.3900.233H		800 x 270 x 28 ø	1736 953 + 1736 853
2	58.3900.443H		800 x 350 x 28 ø	1733 891
	58.3900.433H		800 x 350 x 28 ø	1736 951 + 1736 851
	20.3900.520H		518 x 98	1736 923
	20.5580.140F		293 x 76	1736 917
	20.5580.120H		293 x 76	1736 919

DAFLF

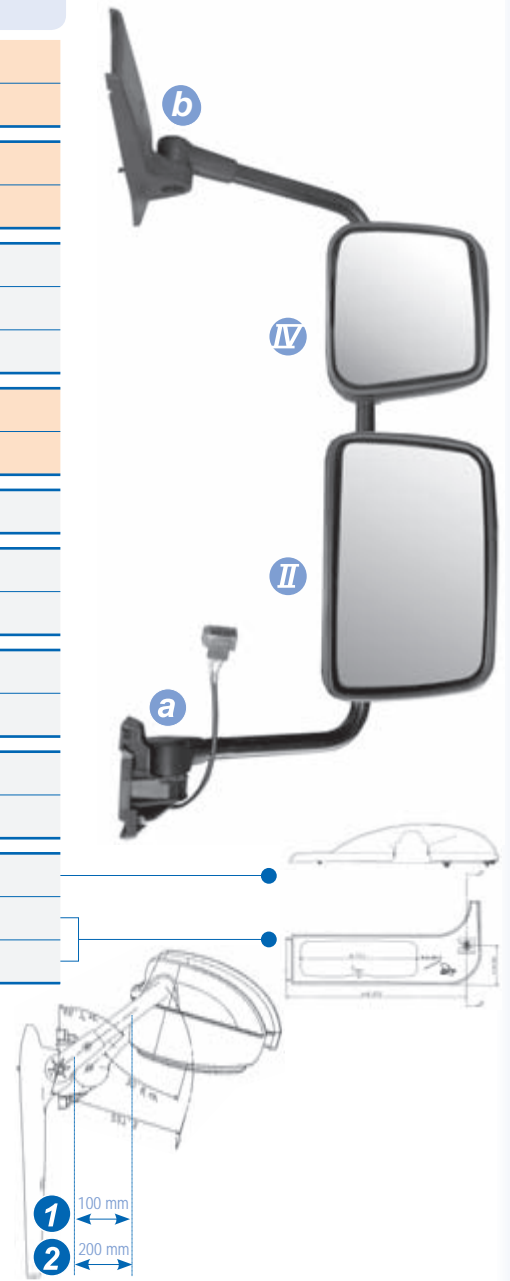

552	V VI 03★0033	V VI 020894			INTEGR.

	Beschreibung description descripción description descripción Benämning Põppis ožetnik		

	59.5524.648.099		725 x 319 x 126	1701 288
	51.5524.930H		319 x 187 x 50	
	20.5520.270		448 x 196	



FENDT

296, 297 universal



385	II e1 02H0469 II (E1) 010469	Truck II ABS	Ø 14-20 mm
MEKRA	Beschreibung description descripition descricao descripcion bernarining popis описывание özellik	mm	OE
51.3850.127H		314 x 228 x 65	G 297.810.150.030
40.2890.222H		300 x 214 x 3	G 297.810.150.010
51.3850.147H		314 x 228 x 65	
40.2890.422H		300 x 214 x 3	
10.6221.100		282 x 162	
09.2000.301H		2000	
51.3850.167H		314 x 228 x 65	
40.2890.422H		300 x 214 x 3	
10.6221.100		282 x 162	
09.3200.410H		2000	
09.3400.420		2000	

diverse Traktoren
various tractors
universal



152 ASKB	II e1 14010	Truck II PP	Ø 10-13 mm
MEKRA	Beschreibung description descripition descricao descripcion bernarining popis описывание özellik	mm	OE
51.1524.119H		260 x 149 x 22	E 178.810.150.019 E 178.810.150.010 F 178.810.150.020 F 178.810.150.020 E 178.810.150.010

FORD

931				INTEGR.
-----	--	--	--	---------

	Beschreibung description descripção descripción benyňnamyng описание özellik		
--	--	--	--

51.9310.110H		305 x 330 x 78	4158406
51.9310.120H		305 x 330 x 78	4087272
51.9310.410H		305 x 330 x 78	1141722
51.9310.420H		305 x 330 x 78	4158420



--	--	--	--	--

	Beschreibung description descripção descripción benyňnamyng описание özellik		
--	--	--	--

39.3730.210H		373 x 190 x 3	6166607 + 1641745
39.3730.410H		373 x 190 x 3	6166609 + 1641752
10.6121.160		340 x 159	



--	--	--	--	--

	Beschreibung description descripção descripción benyňnamyng описание özellik		
--	--	--	--

39.1900.210		193 x 156 x 3	6186601
39.1900.410H		193 x 156 x 3	6186603 + 1653450
10.6321.160		186 x 130	



HINO

03/07

700



330 331	II e1 02★14100 II (E1) 0114100	Truck II	ABS	Ø 14-20 mm
--------------------------	-----------------------------------	----------	-----	------------

MEKRA	Beschreibung description descrip tion descrip tio descrip tione descrip tioon Benamning Розпис описание özellik	mm	OE
51.3310.127H		445 x 215 x 114	
40.3300.218H		429 x 199 x 4	
51.3310.147H		445 x 215 x 114	87 902 0006
40.3302.418H		429 x 199 x 4	87 902 0002G
10.6421.100		400 x 176	
09.2000.301H		2000	
51.3300.147H		445 x 215 x 114	87 902 0006
40.3300.418		429 x 199 x 4	87 902 0002G
10.6421.100		400 x 176	
09.3200.410H		2000	
09.3400.420		2000	

2007

300



363	02★0524 010524 03★0022 010423 02★0423	020923 03★0088 020905 3 03★1456 3 021456	Truck II	ABS	Ø 18-28 mm
------------	---	--	----------	-----	------------

MEKRA	Beschreibung description descrip tion descrip tio descrip tione descrip tioon Benamning Розпис описание özellik	mm	OE
59.3631.322		891 x 376 x 267	87 902 7000
51.3635.206		384 x 205 x 120	07 902 0007
15.3802.840H		368 x 189 x 40	
58.3631.322		891	87 906 7000
59.3631.422		891 x 408 x 267	87 902 7001
51.3636.206		384 x 205 x 120	
15.3802.840H		368 x 189 x 40	
58.3631.422		891	

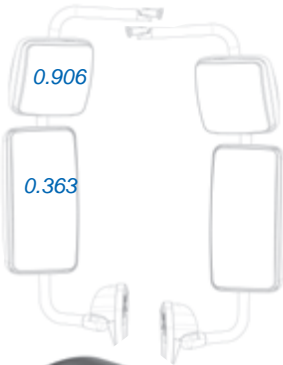

906	IV e1 03★0014	Truck IV	ABS	Ø 28 mm
------------	---------------	----------	-----	---------

MEKRA	Beschreibung description descrip tion descrip tio descrip tione descrip tioon Benamning Розпис описание özellik	mm	OE
61.9065.114H		209 x 218 x 136	87 902 - 0008
15.9060.870H		204 x 195 x 58	87 902 - 0008 G
11.9060.100H		202 x 194 x 55	
56.9065.110		189 x 136	87 902 - 0003 R
15.9060.870H		204 x 195 x 58	87 902 - 0008 G
61.3860.100		210	
11.9060.100H		202 x 194 x 55	

IRISBUS

281 II e1 02★0447 II (E1) 010447 **INTEGR.**
 II e1 02★0448 II (E1) 010448

MEKRA Beschreibung description descripción descripción denominación popis otkrivačnice označnik **OE**

*Aros (Renault,
Karosa, Iveco)
EvoBus Kombibus* *1994* →

1	59.2810.111H		470 x 230 x 85	50.10.411.090
	15.2810.480H		409 x 168 x 6	50.01.851.890
	11.2810.200H		460 x 180 x 50	50.01.851.891
59.2810.113H	59.2810.113H		470 x 230 x 85	50.10.404.852
	15.2810.480H		409 x 168 x 6	50.01.851.890
	11.2810.200H		460 x 180 x 50	50.01.851.891
2	59.2810.211H		550 x 620 x 270	50.10.482.937
	15.2810.480H		409 x 168 x 6	50.01.851.890
	15.2810.470H		157 x 69 x 3	50.01.851.895
	20.2810.110H		113 x 48 x 27	50.10.404.853
	11.2810.200H		460 x 180 x 50	50.01.851.891
	59.2810.213H		550 x 620 x 270	50.10.482.938
15.2810.480H		409 x 168 x 6	50.01.851.890	
15.2810.470H		157 x 69 x 3	50.01.851.895	
20.2810.110H		113 x 48 x 27	50.10.404.853	
11.2810.200H		460 x 180 x 50	50.01.851.891	



IRISBUS

IVECO

250	II e1 01★14002		ABS	Ø 14-20 mm
-----	----------------	--	-----	------------

MEKRA	Beschreibung description description descripção descripção Берлапнинг ропис описание описание		OE
-------	---	--	----

51.2500.127H		375 x 183 x 26	026 014 17
40.2500.222H		366 x 176 x 3	026 125 73
51.2500.147H		375 x 183 x 26	026 281 91
40.2500.422H		366 x 176 x 3	026 281 94
10.6121.100		340 x 159	
09.2070.101H		2070	

253	II e1 02★14067 II (E1) 0114067		ABS	Ø 18 mm
-----	-----------------------------------	--	-----	---------

MEKRA	Beschreibung description description descripção descripção Берлапнинг ропис описание описание		OE
-------	---	--	----

51.2530.120H		370 x 182 x 64	422 093 71 + 860 031 44
40.2530.222H		356 x 170 x 3	422 093 94
61.2530.110H		55 x 43 x 36	422 093 99 + 422 093 70
51.2530.140H		370 x 182 x 64	422 094 01
40.2530.422H		356 x 170 x 3	
10.6121.140		340 x 159	
09.2070.101H		2070	
61.2530.110H		55 x 43 x 36	422 093 99 + 422 093 70

264	IV e1 02★1550 IV (E1) 0187290		ABS	Ø 14-20 mm
-----	----------------------------------	--	-----	------------

MEKRA	Beschreibung description description descripção descripção Берлапнинг ропис описание описание		OE
-------	---	--	----

56.2640.127H		272 x 160 x 65	422 092 32 + 422 092 33 423 457 80 + 423 504 21 984 241 02
40.2647.204H		261 x 149 x 3	422 092 34
56.2640.147		272 x 160 x 65	
10.6321.100		186 x 130	

264	V e1 02★1551 V (E1) 0187291		ABS	
-----	--------------------------------	--	-----	--

MEKRA	Beschreibung description description descripção descripção Берлапнинг ропис описание описание		OE
-------	---	--	----

59.2640.110H		272 x 160 x 65	423 455 22 + 423 291 21 423 455 23 + 423 504 25
40.2647.204H		261 x 149 x 3	422 092 34
11.1523.212		120 x 31 x 14 ø	423 459 81

ANW, AHW, HW, NW 01/74



MK 6-13 t 12/88 - 08/94



Turbo Star 190 universal 07/84 - 12/93



IVECO

1008 V 03★1034 IV 03★1036 **INTEGR.**

MEKRA	Beschreibung description description descripcão descripción Benämning Popis описаније описаније				mm	OE
59.1008.005.099					370 x 799 x 272	504 150 526
59.1008.006.099					370 x 799 x 272	504 150 527
59.1008.007.099					424 x 799 x 287	504 150 534
59.1008.008.099					424 x 799 x 287	504 150 535
59.1008.011.099					424 x 799 x 287	504 150 538
59.1008.012.099					424 x 799 x 287	504 150 539
59.1008.017.099					520 x 811 x 304	504 150 551
59.1008.018.099					520 x 811 x 304	504 150 552
19.1008.041.099					371 x 181	504 197 878
19.1008.311.099					192 x 206	504 197 879

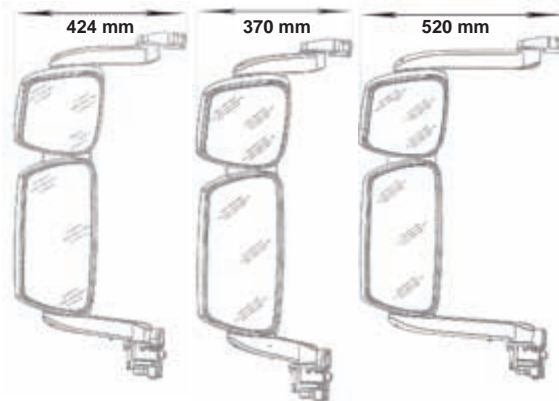

1008 V 03★1031 IV 03★1042

MEKRA	Beschreibung description description descripcão descripción Benämning Popis описаније описаније				mm	OE
56.1008.001.099					270 x 230 x 60	504 168 235
56.1008.002.099					270 x 230 x 60	504 168 236
11.1008.001.099						504 168 244

1008 VI 03★1042 **INTEGR.**

MEKRA	Beschreibung description description descripcão descripción Benämning Popis описаније описаније				mm	OE
55.1008.001.099					136 x 232	504 224 427
55.1008.002.099					136 x 232	504 224 428

Trakker
Eurocargo
Stralis
Tector

NEU
NOUVEAU
NEW



NEU
NOUVEAU
NEW



NEU
NOUVEAU
NEW



IVECO

IVECO

Eurotech, Eurostar,
Eurotrakker
Eurocargo
Stralis

06/93 - 03/06
09/00 - 03/06
2002 - 03/06



460	II E1 02★14102	II E1 0114102		ABS	Ø 22 mm
	II E3 02★58121	II E3 0158121			

MEKRA	Beschreibung description descripción descrizione descripcion benamning Popis описание özellik		mm	OE

1	51.4601.120H		355 x 215 x 140	984 729 77
	51.4601.130H		355 x 215 x 140	984 729 79
	15.4602.164H		340 x 200 x 14	931 931 97
	20.4601.100H		330 x 160 x 70	931 909 71
2	51.4601.230		355 x 215 x 140	984 730 07 ● (984 092 16 ●)
	15.4601.164H		340 x 200 x 14	
	20.4600.200		327 x 152 x 45	931 932 02 ● (931 932 04 ●)

1 MBTF 01F UN U4QB0CESB1 U
glass unit with tension wire
glace sur support avec fil tendeur
unidade de vidro com cabo tensor
specchio con supporto in plastica con cavo tenditore
unidad de cristal con cable tensor
glas på plastplatta med trådfästning
náhradní sklo s deskou a drátem
стекло (наклеенное на пластмассовую пластинку)
с натяжной проволокой
isitici kablolu ayna camı

2 Glaseinheit mit Kunststoffring
glass unit with plastic ring
glace sur support avec bague en plastique
unidade de vidro com abraçadeira de plástico
specchio con supporto con ghiera di plastica
unidad de cristal con abrazadera de plastica
glas på plastplatta med låsring i plast
0 *4 & 0 5-1 5 & 5-17 -417 -' /
стекло (наклеенное на пластмассовую пластинку) с
пластмассовым кольцом
plastik halkali ayna camı

Eurotech, Eurostar,
Eurotrakker
Eurocargo
Stralis

06/93 - 03/06
09/00 - 03/06
2002 - 03/06



461	II E1 02★14103	II E1 0114102		ABS	Ø 22 mm
	II E3 02★57571	II E3 0157571			

MEKRA	Beschreibung description descripción descrizione descripcion benamning Popis описание özellik		mm	OE

1	51.4612.120H		457 x 215 x 140	984 729 82
	51.4612.130H		457 x 215 x 140	984 729 83
	15.4611.164H		440 x 200 x 14	931 909 76
	20.4611.100H		420 x 160 x 70	931 909 77
2	51.4612.230		457 x 215 x 140	984 730 11 ● (814 312 2 ●)
	15.4612.164H		440 x 200 x 14	931 931 98
	20.4610.200		425 x 152 x 50	931 931 61 ●
	20.4610.100H		425 x 152 x 50	931 932 05 ●

1 MBTF 01F UN U4QB0CESB1 U
glass unit with tension wire
glace sur support avec fil tendeur
unidade de vidro com cabo tensor
specchio con supporto in plastica con cavo tenditore
unidad de cristal con cable tensor
glas på plastplatta med trådfästning
náhradní sklo s deskou a drátem
стекло (наклеенное на пластмассовую пластинку)
с натяжной проволокой
isitici kablolu ayna camı

2 Glaseinheit mit Kunststoffring
glass unit with plastic ring
glace sur support avec bague en plastique
unidade de vidro com abraçadeira de plástico
specchio con supporto con ghiera di plastica
unidad de cristal con abrazadera de plastica
glas på plastplatta med låsring i plast
0 *4 & 0 5-1 5 & 5-17 -417 -' /
стекло (наклеенное на пластмассовую пластинку) с
пластмассовым кольцом
plastik halkali ayna camı

IVECO

462 IV 02★11010 IV 0111010 Ø 22 mm
 IV 02★58232 IV 0158232

MEKRA *Bezeichnung description descripción descripción descripción Benennung popis описание оземлік* OE

Eurotech, Eurostar, Eurotrækker Eurocargo Stralis
 06/93 - 03/06
 09/00 - 03/06
 2002 - 03/06



1	56.4621.220H		189 x 215 x 140	984 729 87	
	15.4622.164H		200 x 175 x 14	931 909 73	
	20.4621.100H		154 x 157 x 70	931 909 74	
1	56.4620.247H		189 x 215 x 140	299 6670 + 504 132 248	
	56.4620.267H		189 x 215 x 140	299 6671 + 504 132 249	
	15.4620.870H		200 x 175 x 14	425 484 03	
	20.4621.100H		154 x 157 x 70	931 909 74	
	2	56.4622.200		189 x 215 x 140	984 730 13 ● (814 317 2 ●)
		15.4621.164H		185 x 185 x 14	931 931 99
20.4620.100H			157 x 150 x 45	931 932 03	
	15.4621.870H		200 x 195 x 14		

1 MBTFOIF UNU 4QB00ESBU
 glass unit with tension wire
 glace sur support avec fil tendeur
 unidade de vidro com cabo tensor
 specchio con supporto in plastica con cavo tenditore
 unidad de cristal con cable tensor
 glas på plastplatta med trådfästning
 náhradní sklo s deskou a drátem
 стекло (наклеенное на пластмассовую пластинку)
 с натяжной проволокой
 istici kablolu ayna camı

2 Glaseinheit mit Kunststoffring
 glass unit with plastic ring
 glace sur support avec bague en plastique
 unidade de vidro com abraçadeira de plástico
 specchio con supporto con ghiera di plastica
 unidad de cristal con abrazadera de plástico
 glas på plastplatta med låsring i plast
 0 4 80 5-1 5 8' 5-17 -417 -' /
 стекло (наклеенное на пластмассовую пластинку) с
 пластмассовым кольцом
 plastik halkalı ayna camı

463 V 02★12009 V 0112009
 V 02★46657

MEKRA *Bezeichnung description descripción descripción descripción Benennung popis описание оземлік* OE

Eurotech, Eurostar, Eurotrækker Eurocargo Stralis
 06/93 - 03/06
 09/00 - 03/06
 2002 - 03/06



1	59.4631.320H		284 x 185 x 80	984 729 75
	15.4632.164H		260 x 160 x 10	931 909 84
	59.4630.247H		284	504 132 243
	59.4630.267H		284	504 132 244
	15.4630.870H		260 x 160 x 10	425 587 13 + 984 874 60
2	59.4631.200H		284 x 185 x 80	984 729 38 ● (984 730 00 ●) 984 091 10
	59.4631.300H		284 x 185 x 80	984 091 11 ● (984 730 02 ●) 984 092 60
	15.4631.164H		260 x 160 x 10	931 909 85 + 984 874 65
	15.4631.870H		260 x 160 x 10	

1 MBTFOIF UNU 4QB00ESBU
 glass unit with tension wire
 glace sur support avec fil tendeur
 unidade de vidro com cabo tensor
 specchio con supporto in plastica con cavo tenditore
 unidad de cristal con cable tensor
 glas på plastplatta med trådfästning
 náhradní sklo s deskou a drátem
 стекло (наклеенное на пластмассовую пластинку)
 с натяжной проволокой
 istici kablolu ayna camı

2 Glaseinheit mit Kunststoffring
 glass unit with plastic ring
 glace sur support avec bague en plastique
 unidade de vidro com abraçadeira de plástico
 specchio con supporto con ghiera di plastica
 unidad de cristal con abrazadera de plástico
 glas på plastplatta med låsring i plast
 0 4 80 5-1 5 8' 5-17 -417 -' /
 стекло (наклеенное на пластмассовую пластинку) с
 пластмассовым кольцом
 plastik halkalı ayna camı

MAN

MAN / VW G 90
(6-9 t) 10/75 - 07/88



251 K	II e1 01★14050		ABS	Ø 14-20 mm
-------	----------------	--	-----	------------

MEKRA	Beschreibung description descripção descriptione description Benamning Popis описаније Dzailik					OE
	51.2510.127H	40.2510.222H	39.3120.210H*			
					318 x 186 x 26	81.63730-6167 + 81.63730-6127
					308 x 176 x 3	81.63733-0032
					312 x 180 x 3	81.63733-0027
					318 x 186 x 26	
					308 x 176 x 3	
					282 x 162	
					2070	81.25432-0149
					318 x 186 x 26	81.63730-6128 + 81.63730-6148
					308 x 176 x 3	
					312 x 180 x 3	81.63733-0027
					282 x 162	
					2070	81.25432-0149

364	II e1 02★14082 II E1 0114082		PP	Ø 14-20 mm
-----	---------------------------------	--	----	------------

MEKRA	Beschreibung description descripção descriptione description Benamning Popis описаније Dzailik					OE
	51.3640.127H	40.3640.222H	51.3640.137H	40.3640.322H		
					376 x 187 x 28	81.63730-6108 + 81.63730-6126 81.63730-6149 + 81.63730-6147 81.63730-6148 + 81.63730-6194
					363 x 175 x 4	81.63733-0025 + 81.63733-0030 81.63733-0060
					376 x 187 x 28	
					363 x 175 x 4	
					340 x 159	
					2070	81.25432-0149
					376 x 187 x 28	81.63730-6151 + 81.63730-6001
					363 x 175 x 4	81.63733-0064 + 81.63733-6003 81.63730-0032 + 81.63730-6003 81.63730-6202
					340 x 159	
					2070	81.25432-0149

268	IV e1 02★11013		ABS	Ø 10 mm
-----	----------------	--	-----	---------

MEKRA	Beschreibung description descripção descriptione description Benamning Popis описаније Dzailik					OE
	56.2680.121H	40.2685.204H				
					225 x 172 x 33	81.63730-6217 + 81.63730-6165
					211 x 161 x 3	81.63730-0054

* für MAN VW Baureihe G 90, neue Ausführung, EG Nr. II e1 01*14090
for MAN VW series, new version, EEC no. II e1 01*14090
pour MAN VW série G 90, version nouvelle, CE No. II e1 01*14090
para MAN VW série G 90, nova versão, EEC no. II e1 01*14090
per serie MAN VW G 90, nuova versione, CE No. II e1 01*14090
para MAN VW serie G 90, versión nueva, EEC no. II e1 01*14090
till MAN & VW Modell G 90 nytt utförande, EG nummer II e1 01*14090
pro MAN VW série G 90, nova verzija, EG číslo II e1 01*14090
для MAN VW, серия G 90, новая версия
контрольный номер EC II e1 01*14090
MAN VW serisi, yeni versiyon, EEC no. II e1 01*14090

F8, F9 10/75 - 07/88



















F8, F9 10/75 - 07/88



MAN

267	IV e1 02★11014	 IV		Ø 14-20 mm
------------	-----------------------	---	---	------------

	Beschreibung description descripção descripção descripção benamning popis описание özellik		mm	
---	--	---	----	--

56.2670.127H	   	225 x 172 x 35	
40.2685.204H	 	211 x 161 x 3	81.63730-0054
56.2670.147H	    	225 x 172 x 35	
40.2685.204H	 	211 x 161 x 3	81.63730-0054
10.6321.100	  	186 x 130	
09.2070.101H		2070	81.25432-0149



















F-Typen / types



→ 07/88

260	IV e1 02★11001	 IV		Ø 14-20 mm
------------	-----------------------	---	---	------------

	Beschreibung description descripção descripção descripção benamning popis описание özellik		mm	
---	--	---	----	--

56.2600.127H	   	205 x 158 x 70	81.63730-6206
40.2605.204H	 	190 x 143 x 3	81.63733-0042
56.2600.137H	     	205 x 158 x 70	
56.2600.147H	     	205 x 158 x 70	
09.2070.101H		2070	81.25432-0149

M 90, F90



→ 07/88

156/5 BO	V e1 02★12012	 V		
-----------------	----------------------	--	---	--

	Beschreibung description descripção descripção descripção benamning popis описание özellik		mm	
---	--	---	----	--



56.2441.118H	     	250 x 158 x 41	81.63730-6187 * 81.63730-6208 81.63730-6207 * 81.63730-6216
---------------------	---	----------------	--

F8, F9



156/2 BO		 V		
-----------------	--	--	--	--

	Beschreibung description descripção descripção descripção benamning popis описание özellik		mm	
---	--	---	----	--

56.1560.117H	    	250 x 150 x 25	81.63730-6138
40.1565.104F	 	242 x 143 x 3	



MAN

300 / 310
320

II [e1] 02★14054
II [e1] 02★14053
II (E1) 0114053



① Ø 14-20 mm
② Ø 18-30 mm

MEKRA

Beschreibung
description
descripção
descriptione
descripção
benamning
ррррр
описаније
бэралик



OE

M 90, F90
03/00

1



1	51.3000.127H		380 x 190 x 100	
	40.2500.222H		366 x 176 x 3	
	51.3100.147H		380 x 190 x 100	
	40.2500.422H		366 x 176 x 3	
	10.6121.100		340 x 159	
	09.2070.101H		2070	81.25432-0149
	51.3200.137H		380 x 190 x 100	
	51.3200.146H		380 x 190 x 100	81.63730-6309
	40.3200.422H		366 x 176 x 3	81.63733-0036
	10.6121.150		340 x 159	
	09.3200.410H		2000	
	09.3200.420H		2000	88.25505-0024

2



2	51.3200.147H		380 x 190 x 100	81.63730-6193
	40.3200.422H		366 x 176 x 3	81.63733-0036
	10.6121.150		340 x 159	
	09.3200.410H		2000	
	09.3200.420H		2000	88.25505-0024

340
341

II [e1] 02★14098
II (E1) 0114098



① Ø 14-20 mm
② Ø 20-30 mm

MEKRA

Beschreibung
description
descripção
descriptione
descripção
benamning
ррррр
описаније
бэралик



OE

M 90, F90
8/88-09/94



1	51.3410.127H		377 x 189 x 65	81.63730-6233 + 81.63730-6220
2	51.3412.120H		377 x 189 x 65	81.63730-6420
	40.3640.222H		363 x 175 x 4	81.63733-0025 + 81.63733-0030 81.63733-0060
1	51.3410.147H		377 x 189 x 65	81.63730-6234 + 81.63730-6221 81.62730-6221
2	51.3410.140		377 x 189 x 65	
	40.3640.422H		363 x 175 x 4	81.63733-0064 + 81.63733-6003 81.63730-0032 + 81.63730-6003 81.63730-6202
	10.6121.100		340 x 159	
	09.2000.301H		2000	83.25402-6010
1	51.3400.147H		377 x 189 x 65	88.63730-6041 + 85.63730-6015 81.63730-6016
	40.3640.422H		363 x 175 x 4	81.63733-0064 + 81.63733-6003 81.63730-0032 + 81.63730-6003 81.63730-6202
2	10.6121.150		340 x 159	
	09.3200.410H		2000	
	09.3400.420		2000	

MAN

266	IV e1 02★11008			① Ø 14-20 mm
	IV (E1) 0111008			② Ø 20-30 mm

	Beschreibung description descripcão descripcióe Benämning Ppplis описаније özellik		mm	

1	56.2660.127H		215 x 165 x 55	81.63730-6235 * 81.63730-6222
2	56.2662.120D		215 x 165 x 55	81.63730-6421
	40.2665.204H		200 x 150 x 3	81.63733-0061
1	56.2660.147H		215 x 165 x 55	81.63730-6236 * 81.63730-6223 81.63730-6299
	40.2660.404H		200 x 150 x 3	81.63733-6007
	10.6321.100		186 x 130	
	09.2000.301H		2000	83.25402-6010



265	V e1 02★12007			① Ø 10 mm
	V (E1) 0112007			②

	Beschreibung description descripcão descripcióe Benämning Ppplis описаније özellik		mm	

1	56.2650.121H		247 x 157 x 63	81.63730-6224
	40.2655.204		241 x 150 x 3	
2	59.2652.110H		247 x 157 x 63	
	40.2655.204		241 x 150 x 3	
	58.2652.010			

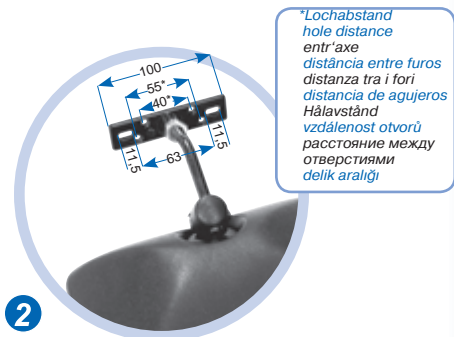

*Lochabstand
hole distance
entr'axe
distància entre furos
distancia tra i fori
distancia de agujeros
Hålavstånd
vzdálenost otvorů
расстояние между
отверстиями
delik aralığı

MAN

F 2000, L 2000
M 2000

09/94
09/97



Handel aftermarket	OEM*
51.3735.121H	51.3801.127
51.3736.121H	51.3802.127
51.3735.124H	51.3801.177
51.3736.124H	51.3802.177
51.3735.126H	51.3801.187
51.3736.126H	51.3802.187
15.3731.070H	15.3801.170
15.3731.074H	15.3801.470
11.3730.310H	11.3800.300

* erhältlich bei MAN
disponible à MAN
ottenibile da MAN
tillgänglig hos MAN
имеется в MAN

available at MAN
disponível para MAN
disponible por MAN
k dostání u MAN
MAN'da bulunabilir

373	II E1 02★0423 II E1 02★0525 II E1 03★0088	II E1 010524 II E1 020923 II E1 020905		ABS	Ø 22 mm
------------	---	--	--	-----	---------

MEKRA	Beschreibung description description description description benimning popis описание özellik				mm	OE
	51.3735.121H	15.3731.070H	51.3736.121H	15.3731.070H		
51.3735.121H					384 x 205 x 120	81.63730-6314 + 81.63730-6331
15.3731.070H					368 x 189 x 40	81.63733-0066 + 81.63730-0066
51.3736.121H					384 x 205 x 120	81.63730-6303 + 81.63730-6332
15.3731.070H					368 x 189 x 40	81.63733-0066 + 81.63730-0066
51.3735.124H					384 x 205 x 120	81.63730-6315 + 81.63730-6365 81.63730-6361
15.3731.074H					368 x 189 x 40	81.63733-0067 + 81.63733-0075 81.63730-0067
51.3736.124H					384 x 205 x 120	81.63730-6304 + 81.63730-6366 81.63730-6362 + 81.63732-0046
15.3731.074H					368 x 189 x 40	81.63733-0067 + 81.63733-0075 81.63730-0067
51.3735.126H					384 x 205 x 120	81.63730-6316 + 81.63730-6367 81.63730-6363 + 81.63732-0051
15.3731.074H					368 x 189 x 40	81.63733-0067 + 81.63733-0075 81.63730-0067
51.3736.126H					384 x 205 x 120	81.63730-6305 + 81.63730-6368 81.63730-6364 + 81.63732-0047
15.3731.074H					368 x 189 x 40	81.63733-0067 + 81.63733-0075 81.63730-0067
11.3730.310H					367 x 187 x 60	

F 2000, L 2000
M 2000

09/94
09/97



Handel aftermarket	OEM*
56.3860.112H	56.3812.127
56.3860.114H	56.3812.147
56.3861.116H	56.3811.167
56.3862.116H	56.3812.167
15.3812.110H	15.3811.110
15.3812.410H	15.3811.410
11.3860.300H	11.3810.300

* erhältlich bei MAN
disponible à MAN
ottenibile da MAN
tillgänglig hos MAN
имеется в MAN

available at MAN
disponível para MAN
disponible por MAN
k dostání u MAN
MAN'da bulunabilir

386	IV E1 02★0424 IV E1 010424		ABS	Ø 22 -28 mm
------------	-------------------------------	--	-----	-------------

MEKRA	Beschreibung description description description description benimning popis описание özellik				mm	OE
	56.3860.112H	15.3812.410H	56.3860.114H	15.3812.410H		
56.3860.112H					219 x 170 x 120	81.63730-6306
15.3812.410H					203 x 154 x 36	81.63733-0069 + 81.63730-0069
56.3860.114H					219 x 170 x 120	81.63730-6307 + 81.63732-0050
15.3812.410H					203 x 154 x 36	81.63733-0069 + 81.63730-0069
56.3861.116H					219 x 170 x 120	81.63730-6317 + 81.63732-0049
15.3812.410H					203 x 154 x 36	81.63733-0069 + 81.63730-0069
56.3862.116H					219 x 170 x 120	81.63730-6308 + 81.63730-6328 81.63732-0048
15.3812.410H					203 x 154 x 36	81.63733-0069 + 81.63730-0069
11.3860.300H					203 x 154 x 60	

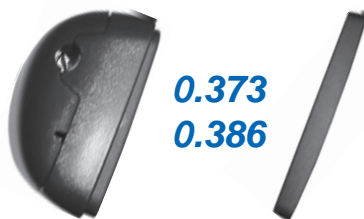

0.373
0.386

- rétroviseur principal et rétroviseur grand angle: vue de profil du boîtier et de la section de la glace sur support
- espelho principal e espelho auxiliar: vista superior do retrovisor / lateral e cantos da unidade de espelho.
- specchio principale & coppa grandangolo: vista superiore della carcassa e sezione del vetro
- espejo principal y espejo de gran ángulo: vista superior de retrovisor / sección lateral y a través de la unidad de espejo
- huvudspegel och vidvinkelspegel: spegelhuvud ovanifrån samt tvärsnitt av glasenhet
- zrcadlo hlavní s zrcadlo širokouhlé: pohled na zrcadlo a průřez náhradním sklem
- главное и широкоугольное зеркало: вид головки зеркала и поперечное сечение стекла, наклеенного на пластмассовую пластинку
- ana ayna ve geniş görüş aynası : ana aynanın yukardan görüntüsü ve ayna camı kesiti
- Haupt & Weitwinkelspiegel: Draufsicht Spiegelkopf & Querschnitt Glaseinheit
- main mirror & wide angle mirror: top view of the mirror head & cross section of the glass unit

MAN

380 II e1 03H0022 II (E1) 010423 Truck II ABS Ø 22 mm

MEKRA Beschreibung description descripción descripción descripción Benennung popis описание оземлік mm OE

51.3801.128D		384 x 205 x 120	82.63730-6001
15.3801.640H		368 x 189 x 40	81.63733-0093
51.3802.128D		384 x 205 x 120	82.63730-6002
15.3801.640H		368 x 189 x 40	81.63733-0093
51.3801.148H		384 x 205 x 120	82.63730-6015
15.3801.840H		368 x 189 x 40	81.63733-0095
51.3802.148H		384 x 205 x 120	82.63730-6016
15.3801.840H		368 x 189 x 40	81.63733-0095
51.3801.168H		384 x 205 x 120	82.63730-6017
15.3801.840H		368 x 189 x 40	81.63733-0095
51.3802.168H		384 x 205 x 120	82.63730-6018
15.3801.840H		368 x 189 x 40	81.63733-0095
11.3800.300H		374 x 196 x 40	81.63732-0044

F 2000, L 2000
M 2000



381 IV e1 03★0023 Truck IV ABS Ø 22 mm

MEKRA Beschreibung description descripción descripción descripción Benennung popis описание оземлік mm OE

56.3812.128H		219 x 170 x 120	82.63730-6022 + 82.63730-6021
15.3811.670H		203 x 154 x 36	81.63733-0097
56.3812.148H		219 x 170 x 120	82.63730-6024 + 82.63730-6023
15.3811.870H		203 x 154 x 36	81.63733-0098
56.3811.168H		219 x 170 x 120	82.63730-6025
15.3811.870H		203 x 154 x 36	81.63733-0098
56.3812.168H		219 x 170 x 120	82.63730-6026
15.3811.870H		203 x 154 x 36	81.63733-0098
11.3810.300H		209 x 160 x 40	81.63732-0078 + 81.63732-0045

F 2000, L 2000
M 2000

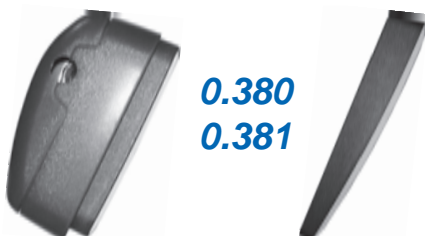

0.380
0.381

- Haupt- & Weitwinkelspiegel: Draufsicht Spiegelkopf & Querschnitt Glaseinheit
- main mirror & wide angle mirror: top view of the mirror head & cross section of the glass unit

- rétroviseur principal et rétroviseur grand angle: vue de profil du boîtier et de la section de la glace sur support
- espelho principal e espelho auxiliar: vista superior do retrovisor / lateral e cantos da unidade de espelho.
- specchio principale & coppa grandangolo: vista superiore della carcassa e sezione del vetro
- espejo principal y espejo de gran ángulo: vista superior de retrovisor / sección lateral y a traves de la unidad de espejo
- huvudspegel och vidvinkelspegel: spegelhuvud ovanifrån samt tvärsnitt av glaset
- zrcadlo hlavní s zrcadlo širokouhlé: pohled na zrcadlo a průřez náhradním sklem
- главное и широкоугольное зеркало: вид головки зеркала и поперечное сечение стекла, наклеенного на пластмассовую пластинку
- ana ayna ve geniş görüş aynası: ana aynanın yukardan görüntüsü ve ayna camı kesiti

reflecting your visions.



MAN

365 394	V e1 02★12015 V (E1) 0112015			
--------------------------	---	--	--	--

MEKRA	Beschreibung description descripção descripció descripcione benamning popis описаније описаник					mm	OE
	59.3941.544H						
40.3655.204						311 x 171 x 3	81.63733-0048
59.3652.147H						324 x 184 x 70	81.63730-6295
40.3650.404H						311 x 171 x 3	81.63733-0049
10.6221.100						282 x 162	
59.3652.167H						324 x 184 x 70	81.63730-6296
40.3650.404H						311 x 171 x 3	81.63733-0049
10.6221.100						282 x 162	

365 394	V e1 03★0015			
--------------------------	---------------------	--	--	--

MEKRA	Beschreibung description descripção descripció descripcione benamning popis описаније описаник					mm	OE
	59.3941.515H						
15.3946.670H						324 x 184 x 6	81.63733-0099
59.3652.148H						324 x 184 x 70	82.63730-6034
15.3946.870H						324 x 184 x 6	81.63733-0100
59.3652.168H						324 x 184 x 70	82.63730-6035
15.3946.870H						324 x 184 x 6	81.63733-0100

09/94 →
09/97 →
F 2000, L 2000
M 2000



MAN

572	II e1 03★0031 II E1 020918	 ABS	① Ø 22 mm ② Ø 28 mm
------------	---	---------	------------------------

	MEKRA Beschreibung description descripção descripzióne descripción Benämning popis описаније özellik	 mm	OE
51.5720.120H		426 x 200 x 135	85.63730-6030
51.5720.127H		426 x 200 x 135	81.63730-6478
40.5725.212H		412 x 188 x 3	81.63733-0101
51.5720.140H		426 x 200 x 135	85.63730-6033
40.5725.412H		412 x 188 x 3	81.63733-0103
51.5721.160H		426 x 200 x 135	85.63730-6035
51.5722.160H		426 x 200 x 135	85.63730-6036
40.5725.412H		412 x 188 x 3	81.63733-0103
51.5721.050		426 x 200 x 135	
51.5722.050H		426 x 200 x 135	
40.5725.112F		412 x 188 x 3	
10.3800.310		340 x 160	

TG-L, TG-M (TG-A) 06/2005
 L2000 06/2005



573	IV e1 03★0032 IV E1 020917	 ABS	① Ø 22 mm ② Ø 28 mm
------------	---	---------	------------------------

	MEKRA Beschreibung description descripção descripzióne descripción Benämning popis описаније özellik	 mm	OE
56.5730.120H		202 x 198 x 126	85.63730-6037
56.5730.127H		202 x 198 x 126	81.63730-6508
40.5735.203H		190 x 184	81.63733-0104
56.5730.140H		202 x 198 x 126	85.63730-6039
40.5735.403H		190 x 184	81.63733-0106
11.3860.700		100 x 22 ø	

TG-L, TG-M (TG-A) 07/2005
 L2000 06/2005



389	IV e1 03★0016	 ABS	INTEGR.
------------	---	---------	---------

	MEKRA Beschreibung description descripção descripzióne descripción Benämning popis описаније özellik	 mm	OE
59.3894.241H		520 x 259 x 92	81.63730-6528
59.3894.242H		520 x 259 x 92	81.63730-6527
51.3894.140		259 x 92 ø	81.63730-0079
40.3965.202H		259 x 2 ø	

TG-L, TG-M (TG-A) 07/2005



MAN

MAN

03/00
2005
04/06

TGA
TGL
TGM



Die Klemmeinheit muß separat bestellt werden.
The clamp has to be ordered separately.
Le nécessaire de fixation doit être commandé séparément.
A abraçadeira deve ser pedida separadamente.
Il dispositivo di bloccaggio deve essere ordinato separatamente.
La abrazadera se debe pedir por separado.
Klammer beställt separat.
Svorka se musí objednat samostatně.
Зажимное устройство заказывается дополнительно.
Keleççe ayrıca sipariş edilmektedir.

392	II [e1] 02★0646		ABS	Ø 28 mm
	II [E1] 010646			
	II [e1] 03★0024			

MEKRA	Beschreibung description description descripção descripzione bernarinnng popis описание özellik				mm	OE
	1	2	3	4		
51.3921.222H					399 x 207 x 137	81.63730-6395 + 81.63730-6345 81.63730-6430
51.3923.222D					399 x 222 x 138	81.63730-6398 + 81.63730-6433
51.3923.232D					399 x 222 x 138	81.63730-6400 + 81.63730-6435
15.3921.870H					379 x 176 x 47	81.63733-0082 + 81.63733-6033
51.3922.222H					399 x 222 x 138	81.63730-6399 + 81.63730-6347 81.63730-6432
51.3922.232H					399 x 222 x 138	81.63730-6401 + 81.63730-6369 81.63730-6434
51.3924.222H					399 x 207 x 137	81.63730-6394 + 81.63730-6431
15.3922.870H					379 x 176 x 47	81.63733-0083 + 81.63733-6034
11.3920.300H					57 x 23 x 30	81.63731-0286
04.0603.004H					30 x 6 ø	
11.3921.110H					399 x 196 x 52	81.63732-0054 + 81.63732-0059
11.3921.120H					399 x 210 x 52	81.63732-0055 + 81.63732-0060
09.3920.110H					680	81.25428-6475



03/00
2005
04/06

TGA
TGL
TGM



















393	IV [e1] 02★0647		ABS	Ø 28 mm
	IV [E1] 010647			
	IV [e1] 03★0025			

MEKRA	Beschreibung description description descripção descripzione bernarinnng popis описание özellik				mm	OE
	1	2	3	4		
56.3931.222H					188 x 207 x 129	81.63730-6409 + 81.63730-6351 81.63730-6443
15.3931.870H					177 x 167 x 38	81.63733-0085 + 81.63733-6037
56.3932.222H					188 x 220 x 130	81.63730-6410 + 81.63730-6350 81.63730-6444
15.3931.870H					177 x 167 x 38	81.63733-0085 + 81.63733-6037
11.3920.300H					57 x 23 x 30	81.63731-0286
04.0603.004H					30 x 6 ø	
11.3931.110H					187 x 197 x 52	81.63732-0057 + 81.63732-0061
11.3931.120H					187 x 209 x 52	81.63732-0056 + 81.63732-0062 81.63732-0066

MAN

392-1 II [E1] 02★0646 II [E1] 010646 II [E1] 03★0024   Ø 28 mm

MEKRA Beschreibung description descripción descripción Benämning Põppis Описание Озеллик  mm 

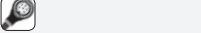
51.3921.224H		399 x 207 x 137	81.63730-6482
51.3923.224H		339 x 222 x 138	81.63730-6487
51.3921.223H		399 x 207 x 137	81.63730-6480
51.3923.223D		399 x 222 x 138	81.63730-6485
51.3923.233H		399 x 222 x 138	81.63730-6493
15.3920.840H		379 x 176 x 47	81.63733-6049
51.3922.224H		399 x 222 x 138	81.63730-6483
51.3924.224H		399 x 207 x 137	81.63730-6486
51.3922.223H		399 x 222 x 138	81.63730-6481
51.3924.223D		399 x 207 x 137	81.63730-6484
51.3922.233H		399 x 222 x 138	81.63730-6492
15.3920.840H		379 x 176 x 47	81.63733-6049
11.3921.400		117 x 62 x 9	81.63731-0309 ♦ 81.63731-0366
11.3920.300H		57 x 23 x 30	81.63731-0286
04.0603.004H		30 x 6 ø	
11.3921.110H		399 x 196 x 52	81.63732-0054 ♦ 81.63732-0059
11.3921.120H		399 x 210 x 52	81.63732-0055 ♦ 81.63732-0060
09.3920.110H		680	81.25428-6475

TGA
TGL
TGM



03/00
2005
04/06











Die Klemmeinheit muß separat bestellt werden.
the clamp has to be ordered separately.
le nécessaire de fixation doit être commandé séparément.
A abrazadeira deve ser pedida separadamente.
il dispositivo di bloccaggio deve essere ordinato separatamente.
La abrazadera se debe pedir por separado.
Klammer bestills separat.
Svorka se musí objednat samostatně.
заклиночное устройство заказывается дополнительно.
кеглерге ayrıca sipariş edilmelidir.

2  + 2 

4 

393-1 IV [E1] 02★0647 IV [E1] 010647 IV [E1] 03★0025   Ø 28 mm

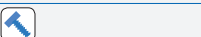
MEKRA Beschreibung description descripción descripción Benämning Põppis Описание Озеллик  mm 

56.3931.343H		188 x 207 x 129	81.63730-6510
56.3931.323H		188 x 207 x 129	81.63730-6512
15.3932.870H		177 x 167 x 38	81.63733-6057
56.3932.343H		188 x 220 x 130	81.63730-6511
56.3932.323H		188 x 220 x 130	81.63730-6513
15.3932.870H		177 x 167 x 38	81.63733-6057
11.3921.400		117 x 62 x 9	81.63731-0309 ♦ 81.63731-0366
04.0603.004H		30 x 6 ø	
11.3931.110H		187 x 197 x 52	81.63732-0057 ♦ 81.63732-0061
11.3931.120H		187 x 209 x 52	81.63732-0056 ♦ 81.63732-0062

TGA
TGL
TGM

03/00
2005
04/06



MAN

03/00
2005
04/06

TGA
TGL
TGM

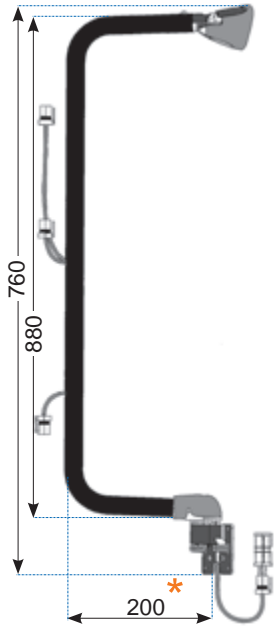

392			Ø 28 mm
------------	--	--	---------

MEKRA	Beschreibung description descripção descricao Benämning Popis описание Özellik	mm	OE
58.3922.021H		880 x 200 x 28 ø	81.63731-6557
58.3922.321H		880 x 200 x 28 ø	81.63731-6560 + 81.63731-6467
58.3922.221D		880 x 200 x 28 ø	81.63731-6559
58.3922.121H		880 x 200 x 28 ø	81.63731-6558

*
weitere Ausladungen auf Anfrage
other widths on request
autre empattements sur demande
para medidas adicionais, solicite informações
altre larghezze su richiesta
sue puede pedir más información
sobre medidas adicionales
andra dimensioner vid förfrågan
ostatni rozměry na dotaz
Другие выступы возможны по запросу
diğer kol genişlikleri talebe bađlı

03/00
2005
04/06

TGA
TGL
TGM



394	V [e1] 02★12015 V (E1) 0112015 V [e1] 03★0015		
------------	---	--	--

MEKRA	Beschreibung description descripção descricao Benämning Popis описание Özellik	mm	OE
59.3941.212H		324 x 185 x 80	81.63730-6352 + 81.63730-6449
15.3941.670H		309 x 170 x 15	81.63733-6041
59.3941.222H		324 x 185 x 80	81.63730-6415 + 81.63730-6353 81.63730-6450
15.3941.870H		309 x 170 x 15	81.63733-0087 + 81.63733-6042

394-1	V [e1] 02★12015 V (E1) 0112015 V [e1] 03★0015		
--------------	---	--	--

MEKRA	Beschreibung description descripção descricao Benämning Popis описание Özellik	mm	OE
59.3941.413H		324 x 185 x 80	81.63730-6573 + 81.63730-6522
15.3942.650H		324 x 185 x 15	81.63733-6061 + 81.63733-6067
59.3941.423H		324 x 185 x 80	81.63730-6574 + 81.63730-6523
15.3942.850H		324 x 185 x 15	81.63733-6068 + 81.63733-6062

MAN

580 II E1 03★0097 II E1 020929 II+IV ABS INTEGR.

IV E1 03★0098 IV E1 020930

MEKRA Beschreibung description descripción descripción denominación mm OE

1	59.5800.101H		943 x 382 x 153	81.63730-6529
	59.5800.102H		943 x 382 x 153	81.63730-6560
	59.5800.302H		943 x 382 x 153	81.63730-6563
	59.5800.201H		943 x 382 x 153	81.63730-6531
	59.5800.202H		943 x 382 x 153	81.63730-6561
	59.5800.203H		943 x 382 x 153	81.63730-6564
	59.5800.402H		943 x 382 x 153	81.63730-6562
	58.5800.101H		943 x 28	81.63731-6638
	58.5800.102H		943 x 28	81.63731-6639
2	59.5800.121H		943 x 437 x 153	81.63730-6533
	59.5800.122H		943 x 437 x 153	81.63730-6549
	59.5800.322H		943 x 437 x 153	81.63730-6552
	59.5800.221H		943 x 437 x 153	81.63730-6534
	59.5800.222H		943 x 437 x 153	81.63730-6550
	59.5800.422H		943 x 437 x 153	81.63730-6551
		58.5800.201H		943 x 28 ø
58.5800.202H			943 x 28	81.63731-6641
	15.5801.840H		381 x 201	81.63733-6071
	15.5811.871H		197 x 181 x 42	81.63733-6073
	15.5811.872H		197 x 181 x 42	81.63733-6072
	13.5800.100H		634 x 259 x 90	81.63732-0091
	11.5800.100H		631 x 237 x 174	81.63731-0356
	20.5800.410H		289 x 149 x 85	81.63732-0073
	20.5800.420H		289 x 149 x 85	81.63732-0074
	20.5800.610H		242 x 140 x 94	81.63732-0075
	20.5800.620H		242 x 140 x 94	81.63732-0076
	20.5800.710H			81.62410-0107
	20.5800.720H			81.62410-0108
	20.5800.750H		13 x 19 ø	81.63732-0090

TGX / TGS

NEU NOUVEAU NEW



bei MAN erhältlich
 available at MAN
 disponible à MAN
 disponível para MAN
 ottenibile da MAN
 disponible por MAN
 tilgänglich hos MAN
 k dostání u MAN
 имеется в MAN
 MAN da bulunabilir

reflecting your visions.



MAN

MAN Lion's City
 Lion's Regio -
 Lion's Star
 NAG
 KRAFTEX, SOLARIS
 (URBINO), VDL (Citelis),
 Universal

2007
 2008



MAN

277 II e1 03★0084 II (E1) 020915 ABS INTEGR.

MEKRA		Beschreibung description descripción descriptione descripcion benamning popis описание özellik		mm		OE	
59.2770.110		1001 x 720 x 254	88.63700-6064				
15.2771.840		307 x 183 x 23	81.63733-0110				
15.2771.870		206 x 166 x 37	81.63733-0111				
09.2770.220		124 x 59	88.25426-6836				
59.2770.210		1001 x 720 x 254	88.63700-6062				
15.2771.840		307 x 183 x 23	81.63733-0110				
15.2771.870		206 x 166 x 37	81.63733-0111				
09.2770.210		124 x 59	88.25426-6837				
59.2771.210		1001 x 720 x 254	88.63700-6060				
15.2771.840		307 x 183 x 23	81.63733-0110				
15.2771.870		206 x 166 x 37	81.63733-0111				
09.2770.230		124 x 59					
08.2770.001.000		435 x 45	81.25505-6247				

278 II e1 03★0128 II (E1) 020951 IV e1 03★0129 IV (E1) 020952 ABS



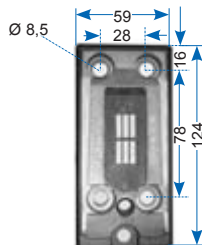
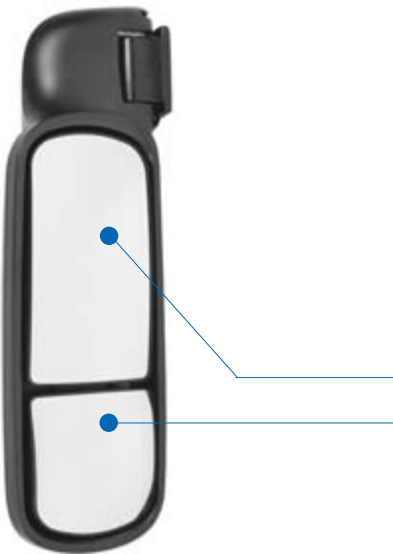













MEKRA		Beschreibung description descripción descriptione descripcion benamning popis описание özellik		mm		OE	
59.2780.110		684 x 247 x 174	88.63700-6063				
15.2780.840		307 x 177 x 22	81.63733-0113				
15.2780.870		177 x 177 x 34	81.63733-0112				
20.2780.631		124 x 59	88.63731-6129				
59.2780.120		684 x 247 x 174	88.63700-6059				
15.2780.840		307 x 177 x 22	81.63733-0113				
15.2780.870		177 x 177 x 34	81.63733-0112				
20.2780.630		124 x 59	88.63731-6131				
59.2781.120		684 x 247 x 174					
15.2780.840		307 x 177 x 22	81.63733-0113				
15.2780.870		177 x 177 x 34	81.63733-0112				
20.2780.630		124 x 59	88.63731-6131				











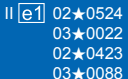
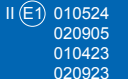



























































Aufsteckkeil
 mounting wedge
 semelle de fixation
 Cunhas desmontáveis
 supporto a cuneo
 cuña desmontable
 monteringskilar
 nástrčný klín
 насадочный клин
 bağlantı parçası

MAN

256    Ø 30 mm

MEKRA	Beschreibung description description descripção descripción benymining pppiss описаније özellik			OE
				
55.2561.010			545 x 219 x 227	88.63730-6077
15.2561.640		 1200	324 x 201 x 17	81.63733-0114
15.2561.600		 plan	199 x 195 x 17	81.63733-0115
55.2561.110			545 x 219 x 227	88.63730-6078
15.2561.640		 1200	324 x 201 x 17	81.63733-0114
15.2561.600		 plan	199 x 195 x 17	81.63733-0115
09.2560.200			7000 x 6 Ø	88.25427-6785

271  02★0524
03★0022
02★0423
03★0088  010524
020905
010423
020923     

MEKRA	Beschreibung description description descripção descripción benymining pppiss описаније özellik			OE
				
59.2712.111			783 x 703 x 212	83.63700-6502 ÷ 81.63700-6091
51.3731.326		 24 V 	384 x 205 x 116	81.63730-6375
15.3731.470H		 PTC  1800 	368 x 189 x 40	81.63733-6029 ÷ 81.63733-0075
15.2711.114		 240	165 x 93	81.63733-6027
11.3730.210H			367 x 187 x 60	81.63732-0058
20.2480.216H		  	108 x 50 x 15 / 2000	83.63731-6507
20.2480.221			108 x 50 x 15 / 2500	81.63731-6471
59.2712.114			701 x 641 x 200	83.63700-6501 ÷ 81.63700-6092
51.3732.326H		 24 V 	384 x 205 x 116	81.63730-6374 ÷ 81.63730-6390
15.3731.470H		 PTC  1800 	368 x 189 x 40	81.63733-6029 ÷ 81.63733-0075
15.2711.114		 240	165 x 93	81.63733-6027
15.2712.114		 240	152 x 128	81.63733-6028
11.3730.210H			367 x 187 x 60	81.63732-0058
20.2480.222			108 x 50 x 15	81.63731-6470
59.2718.112			701 x 641 x 200	
51.3732.326H		 24 V 	384 x 205 x 116	81.63730-6374 ÷ 81.63730-6390
15.3731.470H		 PTC  1800 	368 x 189 x 40	81.63733-6029 ÷ 81.63733-0075
15.2711.114		 240	165 x 93	81.63733-6027
15.2712.114		 240	152 x 128	81.63733-6028
11.3730.210H			367 x 187 x 60	81.63732-0058
20.2710.630H			124 x 59 x 18 / 2500	36.63731-6001
20.2710.111H		 3,4°/0°	183 x 145 x 107	81.63731-6469
20.2710.121		 3,4°/0° a	183 x 145 x 107	81.63731-6468
20.2710.132D		 3,4°/12° a	180 x 145	81.63731-6539
20.2710.142D		 3,4°/12° a	145 x 185 x 90	81.63731-6540
20.2710.200H		b	183 x 181 x 84	81.63731-0289

MAN Lion's City
Lion's Regio
Lion's Star
NAG 2008, 2007
Universal



Intercity Mega S 2000
R07/08, A 20 09/99
Euroliner 09/01
Neoman Tourliner 2003
Lions Coach Fortuna



reflecting your visions.



MAN

Neoplan Trendliner 2002



276 II E1 02★0524 II E1 010524
 03★0022 020905
 02★0423 010423
 03★0088 020923

Truck II ABS

MEKRA

Beschreibung description descripción descripción descripción Benamning Popis описаније Označenie

mm

OE

1	59.2762.101		600 x 205 x 120	
	51.3732.326H		384 x 205 x 116	81.63730-6374 + 81.63730-6390
	15.3731.470H		368 x 189 x 40	81.63733-6029 + 81.63733-0075
	11.3730.210H		367 x 187 x 60	81.63732-0058
	59.2762.201		701 x 641 x 200	
	51.3731.326		384 x 205 x 116	81.63730-6375
	15.3731.470H		368 x 189 x 40	81.63733-6029 + 81.63733-0075
	11.3730.210H		367 x 187 x 60	81.63732-0058
2	59.2762.322		364 x 205	
	51.3732.326H		384 x 205 x 116	81.63730-6374 + 81.63730-6390
	15.3731.470H		368 x 189 x 40	81.63733-6029 + 81.63733-0075
	11.3730.210H		367 x 187 x 60	81.63732-0058
	59.2762.422		364 x 205	
	51.3732.326H		384 x 205 x 116	81.63730-6374 + 81.63730-6390
	15.3731.470H		368 x 189 x 40	81.63733-6029 + 81.63733-0075
	11.3730.210H		367 x 187 x 60	81.63732-0058
	20.2710.620		124 x 59 x 18 / 500	36.63731-6000
	20.2710.630H		124 x 59 x 18 / 2500	36.63731-6001

Neoplan Euroliner 2002

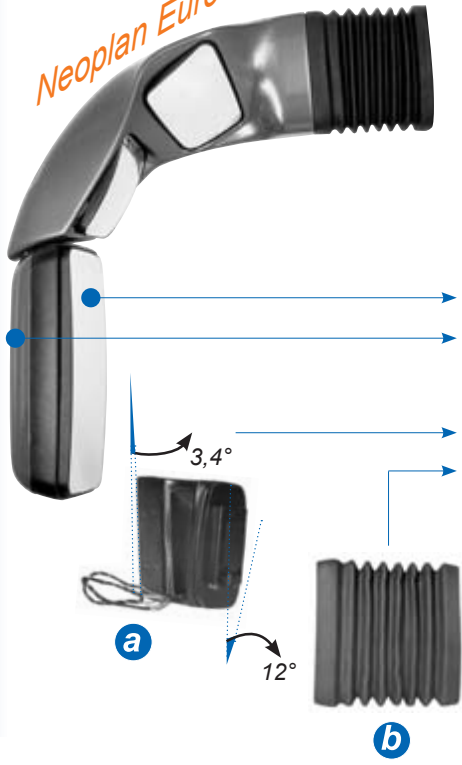

271 II E1 02★0524 II E1 010524
 03★0022 020905
 02★0423 010423
 03★0088 020923

Truck II ABS PU

MEKRA

Beschreibung description descripción descripción descripción Benamning Popis описаније Označenie

mm

OE

	59.2718.112		701 x 641 x 200	
	51.3732.326H		384 x 205 x 116	81.63730-6374 + 81.63730-6390
	15.3731.470H		368 x 189 x 40	81.63733-6029 + 81.63733-0075
	11.3730.210H		367 x 187 x 60	81.63732-0058
	20.2710.630H		124 x 59 x 18 / 2500	36.63731-6001
	20.2710.142D		a	145 x 185 x 90 81.63731-6540
	20.2710.200H		b	183 x 181 x 84 81.63731-0289

MERCEDES

244



MEKRA

Beschreibung
description
descripção
descripção
descripção
benamning
popis
описание
özellik



OE

1	51.2440.217H		1	346 x 155 x 41	314 811 01 30 + 314 811 00 30
2	51.2440.117H		2	246 x 155 x 41	314 811 03 30 + 000 811 46 30 314 811 01 33
	11.2440.120H		a	60	314 811 00 14
	11.2440.130H		b	117	337 811 50 14 + 322 811 03 14

249 K

III e1 01★17023



1 Ø 10 mm
2 Ø 12 mm

MEKRA

Beschreibung
description
descripção
descripção
descripção
benamning
popis
описание
özellik



OE

	51.2491.121H		1	210 x 140 x 21	460 810 01 16 + 601 810 02 16 460 810 03 16
	51.2491.122H		2	210 x 140 x 21	601 810 01 16

156/4 BO

V e1 02★12012
V E1 0112012



MEKRA

Beschreibung
description
descripção
descripção
descripção
benamning
popis
описание
özellik



OE

	56.2441.117H			250 x 158 x 41	314 810 25 16
--	--------------	--	--	----------------	---------------

249L
249L (14-20)

II e1 02★14035
II E1 0114035



1 Ø 10 mm
2 Ø 14 - 20 mm

MEKRA

Beschreibung
description
descripção
descripção
descripção
benamning
popis
описание
özellik



OE

	51.2493.121H			247 x 157 x 61	612 810 01 66 + 611 810 01 16
	51.2493.131H			247 x 157 x 61	601 810 22 16 + 601 810 09 16
	09.2070.101H			2070	000 150 55 33
	51.2493.127H			247 x 157 x 61	
	51.2493.137H			247 x 157 x 61	
	09.2070.101H			2070	000 150 55 33

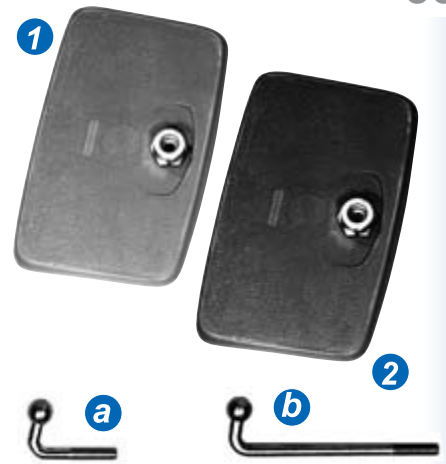

Transporter 207D - 308
(T1, TN) 05/77 - 07/81 Typ
230 (GE), 280 GE, Typ 240
GD, 300 GD 05/79



alte Baureihen / old series
→ 12/86



Transporter 207D - 410 (T1,
TN) 08/81 - 02/95



MERCEDES

MERCEDES

1013 - 2644
EvoBus
D 303, 404, 405, 407
08/73 - 12/86



253	II e1 02★14067 II (E1) 0114067			Ø 18 mm
------------	-----------------------------------	--	--	---------

MEKRA	Beschreibung description description description description Бернарнинг popis описаније описаније					OE
	51.2530.120H	40.2530.222H	61.2530.110H			
					370 x 182 x 64	381 810 25 16 + 000 810 27 16 281 810 71 16 + 000 810 62 16 000 811 12 33 + 314 810 26 16 381 810 71 16 + 663 810 08 16 673 810 08 16 + 673 810 40 16 000 811 33 33 + 001 811 87 33 000 811 20 33 + 000 811 64 33 000 811 21 33
					370 x 182 x 64	281 810 73 16 + 381 810 26 16 000 810 23 16 + 301 810 21 16 314 810 26 16 + 673 810 42 16
					356 x 170 x 3	000 821 03 29 + 000 821 05 29
					340 x 159	000 821 03 29 + 000 821 05 29
					2070	000 150 55 33
					55 x 43 x 36	000 811 02 39

MERCEDES

LK08 - 1113
LN2 (LK)
11/77
12/98



254	II e1 01★14068			Ø 18 mm
------------	----------------	--	--	---------

MEKRA	Beschreibung description description description description Бернарнинг popis описаније описаније					OE
	51.2540.120H	40.2540.222H	61.2540.110H			
					305 x 183 x 60	314 810 13 16 + 000 810 04 16 000 810 48 16 + 673 810 39 16 000 811 35 33 + 001 811 90 33 000 811 19 33
					305 x 183 x 60	314 810 19 16 + 000 810 06 16 000 810 20 16
					293 x 172 x 3	
					282 x 162	000 821 09 29 + 000 810 09 29
					2070	000 150 55 33
					55 x 43 x 36	000 811 02 39
					305 x 183 x 60	314 810 20 16 + 673 810 41 16
					291 x 170 x 3	001 811 90 33
					282 x 162	000 821 08 29
					2070	000 150 55 33
					55 x 43 x 36	000 811 02 39

MERCEDES

258	II e1 02★14069		ABS	Ø 18 mm
	II E1 0114069			

MEKRA	Beschreibung description descripción descrizione descripción Benimning popis описаније ozeilnik		OE
51.2580.120H		423 x 203 x 72	381 810 37 16 ÷ 000 811 28 33
40.2580.222H		408 x 184 x 3	000 810 34 33 ÷ 001 811 84 33 000 811 34 33
61.2530.110H		55 x 43 x 36	000 811 02 39
51.2580.140H		423 x 203 x 72	381 810 38 16
40.2580.422H		408 x 184 x 3	000 811 38 33
10.6421.140		400 x 176	000 821 11 29
09.2070.101H		2070	000 150 55 33
61.2530.110H		55 x 43 x 36	000 811 02 39
51.2580.160H		423 x 203 x 72	381 810 39 16 ÷ 673 810 43 16
61.2530.110H		55 x 43 x 36	000 811 02 39

1422-2633
EvoBus D 303, 304
05/82 - 08/94
02/83-06/93



285	IV e1 02★11012		ABS	Ø 18 mm
	IV E1 0111012			

MEKRA	Beschreibung description descripción descrizione descripción Benimning popis описаније ozeilnik		OE
56.2850.120H		423 x 203 x 72	673 810 46 16
39.1720.210H		171 x 171 x 3	000 811 90 33 ÷ 000 811 54 33 001 811 77 33 ÷ 000 810 51 33 000 811 51 33
61.2530.110H		55 x 43 x 36	000 811 02 39
56.2850.140H		423 x 203 x 72	673 810 47 16 ÷ 000 810 28 16
39.1720.410H		171 x 171 x 3	001 811 79 33 ÷ 000 811 94 33 000 810 54 33 ÷ 000 811 56 33
10.3710.400		160 x 154	
09.2070.101H		2070	000 150 55 33
61.2530.110H		55 x 43 x 36	000 811 02 39

11/87
LK 814
EvoBus D 303, 304
02/83 - 06/93



MERCEDES

MERCEDES

SK (NG 90/1) 08/88 - 12/90



282	II e1 02★14083			Ø 22 mm
	II (E1) 0114083			

MEKRA	Beschreibung description description description description Benämning Popis описание özellik					OE
	51.2820.120H	39.4170.210H	51.2820.140H	39.4170.410H		
					430 x 216 x 105	641 810 00 16
					417 x 197 x 3	000 811 70 33 + 001 811 85 33
					430 x 216 x 105	641 810 01 16
					417 x 197 x 3	000 811 70 33 + 000 821 00 29 + 001 811 85 33 + 000 821 00 29
					400 x 176	000 821 00 29
					430 x 216 x 105	641 810 02 16
					402 x 181 x 2	000 811 69 33
						641 811 05 39

SK (NG 90/1) 08/88 - 12/90



283	IV (E1) 010392			Ø 22 mm

MEKRA	Beschreibung description description description description Benämning Popis описание özellik					OE
	56.2830.120H	39.2088.504	56.2830.140H	39.2050.110		
					216 x 196 x 64	673 810 37 16 + 641 810 20 16
					206 x 188 x 3	001 811 78 33
					216 x 196 x 64	673 810 38 16 + 641 810 21 16
					206 x 188 x 3	
					186 x 130	
						641 811 07 39



für Normkabine
for normal cabin
pour cabine normale
para cabine normal
per cabina normale
para cabina normal
föör normal kabin
pro normální kabinu
для нормальной кабины
normal kabinler için

SK (NG 90/1) 08/88 - 12/90



284	V e1 02★12003			
	V (E1) 0112003			

MEKRA	Beschreibung description description description description Benämning Popis описание özellik					OE
	59.2840.120H	39.3188.504	20.2840.110	11.3610.310		
					340 x 173 x 80	641 810 40 16 + 641 810 22 16 673 810 36 16
					318 x 162 x 3	001 811 89 33 + 000 811 89 33
					80	641 811 01 31
						641 811 04 14

MERCEDES

SK (NG 90/II) 01/91 - 08/96

368	II e1 02★14123		ABS	Ø 28 mm
	II (E1) 0114123			

MEKRA	Beschreibung description descripción descrizione descripción بەناوی opis описание açıklık		OE

51.3680.147H		440 x 182 x 132	641 810 42 16 + 641 810 68 16
40.3680.222H		427 x 169 x 3	000 811 84 33 + 001 811 86 33
40.3680.422H		427 x 169 x 3	
10.3681.400		409 x 148	000 821 01 29

51.3680.167H		440 x 182 x 132	641 810 44 16
40.3680.222H		427 x 169 x 3	000 811 84 33 + 001 811 86 33
40.3680.422H		427 x 169 x 3	
10.3681.400		409 x 148	000 821 01 29



367	IV e1 02★0394		ABS	Ø 28 mm
	IV (E1) 010394			

MEKRA	Beschreibung description descripción descrizione descripción بەناوی opis описание açıklık		OE

56.3670.147H		225 x 185 x 129	641 810 46 16 + 000 810 70 16
40.3675.204H		209 x 169 x 3	000 811 85 33 + 001 811 81 33
40.3670.404H		209 x 169 x 3	
10.3670.410H		190 x 150	000 821 02 29 + 000 821 04 29

SK (NG 90/II) 01/91 - 08/96



269	V e1 02★12010		ABS	
	V (E1) 0112010			

MEKRA	Beschreibung description descripción descrizione descripción بەناوی opis описание açıklık		OE

1	59.2690.127H		294 x 164 x 45	641 810 47 16 + 641 810 63 16
	40.2695.204H		282 x 152 x 3	000 811 86 33
2	59.2693.127H		294 x 164 x 45	673 810 48 16 + 673 810 49 16
	40.2695.204H		282 x 152 x 3	000 811 86 33

SK (NG 90/II) 01/91 - 08/96



MERCEDES

reflecting your visions.



MERCEDES

Actros (SKL) I+II 09/96 - 05/08
Econic 03/98



378
378-1

II [e1] 02★0463
II [E1] 010463
II [e1] 03★0018



Ø 28 mm

MEKRA

Beschreibung
description
description
description
description
Benamning
Popis
описание
Özellik

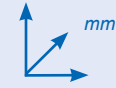

OE

61.3780.147H		433 x 188 x 85	000 810 95 16 + 001 811 20 33 + 000 811 13 07
61.3782.147H		433 x 188 x 68	000 810 95 16
15.3784.470H		433 x 188 x 15	001 811 20 33
61.3780.100H		74 x 65 x 14	000 811 13 07
61.3783.147H		433 x 188 x 68	001 810 90 16
15.3780.840H		433 x 188 x 15	002 811 04 33
61.3780.100H		74 x 65 x 14	000 811 13 07
61.3782.167H		433 x 188 x 68	000 810 94 16
15.3784.470H		433 x 188 x 15	001 811 20 33
61.3780.100H		74 x 65 x 14	000 811 13 07
61.3783.167H		433 x 188 x 68	001 810 91 16
15.3780.840H		433 x 188 x 15	002 811 04 33
61.3780.100H		74 x 65 x 14	000 811 13 07

Actros (SKL) I+II 09/96 - 05/08
Econic 03/98



377
377-1

IV [e1] 02★0462
IV [E1] 010462
IV [e1] 03★0019



Ø 28 mm

MEKRA

Beschreibung
description
description
description
description
Benamning
Popis
описание
Özellik



OE

61.3770.147H		200 x 200	000 810 96 16 + 001 811 21 33 + 000 811 13 07
61.3772.147H		200 x 200 x 68	000 810 96 16
15.3774.410H		200 x 200 x 15	001 811 21 33
61.3780.100H		74 x 65 x 14	000 811 13 07
61.3773.147H		200 x 200	001 810 92 16 + 000 811 13 07
15.3771.174H		200 x 200 x 15	001 811 60 33
61.3780.100H		74 x 65 x 14	000 811 13 07

MERCEDES

*Actros (SKL) I+II
Econic*
09/96 →
03/98 →

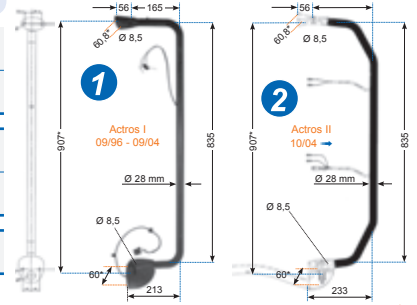

Actros (SKL) I+II 09/96 - 05/07



Actros (SKL)
06/07 →



Econic
03/98 - 05/07
06/07 →



378					Ø 28 mm
		Beschreibung description descripción descripção descripção Beschreibung pppiss описаније özellik			
1	58.3781.100H		983 x 197 x 28 Ø	001 810 44 14	
	58.3781.200H		983 x 197 x 28 Ø	001 810 45 14	
2	58.3783.300H		983 x 227 x 28 Ø	002 810 08 14	
	58.3783.200H		983 x 227 x 28 Ø	002 810 09 14	
	20.3780.700H		100 x 90	941 811 00 07	

379 379-1		V 02★0464 V 010464 V 03★0013				
		Beschreibung description descripción descripção descripção Beschreibung pppiss описаније özellik				
	59.3792.127H		310 x 170 x 83	941 810 10 16 + 941 810 21 16		
	15.3794.410H		310 x 170 x 15	001 811 22 33		
	59.3793.127H		310 x 170 x 83	940 810 26 16		
	15.3791.470H		310 x 170 x 15	002 811 03 33		

579		V 03★0109				
		Beschreibung description descripción descripção descripção Beschreibung pppiss описаније özellik				
	59.5790.110H		303 x 163	002 810 08 16		
	15.5791.470H		303 x 163	002 811 22 33		
	20.3790.500		116	000 811 04 96		

360 360-1		V 02★12013 V 0112013 V 03★0039 V 020973				INTEGR.
		Beschreibung description descripción descripção descripção Beschreibung pppiss описаније özellik				
	59.3602.128H		284 x 174 x 62	957 810 00 16		
	40.3605.204		272 x 162 x 3	957 811 00 33		
	59.3604.178H		284 x 174 x 64	957 810 26 16		
	40.3605.403H		272 x 162 x 3	002 811 21 33		

MERCEDES

MERCEDES

375

 II E1 03★0123 II E1 020941
 II E1 02★0505 II E1 010505

ABS

Ø 28 mm

MEKRA

 Beschreibung
 description
 descripción
 descrizione
 descripción
 Benamning
 popis
 описание
 özalik

OE

61.3752.147H		380 x 170 x 68	000 810 02 79
15.3752.470H		380 x 170 x 15	001 811 34 33 + 001 811 73 33
15.3750.840H		380 x 170 x 15	
61.3780.100H		74 x 65 x 14	000 811 13 07
61.3752.167H		380 x 170 x 68	000 810 03 79
15.3752.470H		380 x 170 x 15	001 811 34 33 + 001 811 73 33
15.3750.840H		380 x 170 x 15	
61.3780.100H		74 x 65 x 14	000 811 13 07

377

377-1

IV E1 02★0462

IV E1 010462

IV E1 03★0019



ABS

Ø 28 mm

MEKRA

 Beschreibung
 description
 descripción
 descrizione
 descripción
 Benamning
 popis
 описание
 özalik

OE

61.3770.147H		200 x 200	000 810 96 16 + 001 811 21 33 + 000 811 13 07
61.3772.147H		200 x 200 x 68	000 810 96 16
15.3774.410H		200 x 200 x 15	001 811 21 33
61.3780.100H		74 x 65 x 14	000 811 13 07
61.3773.147H		200 x 200	001 810 92 16 + 000 811 13 07
15.3771.174H		200 x 200 x 15	001 811 60 33
61.3780.100H		74 x 65 x 14	000 811 13 07

375



Ø 28 mm

MEKRA

 Beschreibung
 description
 descripción
 descrizione
 descripción
 Benamning
 popis
 описание
 özalik

OE

58.3752.100		639 x 325	973 810 03 14
58.3752.200		639 x 325	973 810 04 14
58.3752.300E		639 x 325	973 810 07 14
58.3752.400E		639 x 325	973 810 08 14
20.3750.710		136 x 82	000 811 03 61
20.3750.720		136 x 82	000 811 04 61

* Die Kunststoff - Abdeckung für den Haltebock der Spiegelstange muß separat bestellt werden.

The plastic cover for the lower holder of the mirror bracket must be ordered separately.

Le cache du support de fixation du bras du rétroviseur doit être commandé séparément.

A cobertura plástica inferior do braço de fixação deve ser pedida separadamente.

La calotta di plastica per il supporto inferiore del braccio deve essere ordinata separatamente.

La cubierta de plástico de la parte inferior del soporte debe ser pedida separadamente.

Plastkåpan till det nedre fästet på bågen, måste beställas separat.

Plastová kryčka pro kloub držáku se musí objednat samostatně.

Пластмассовая облицовка для держательной подставки бруса зеркала должна заказываться отдельно.

Ayna kolunun alt bağlantı plastik kapağı ayrıca sipariş edilmelidir.

Atego (LKN)
Axor

01/98 - 09/04
09/01 - 09/04



Atego (LKN)
Axor

01/98 - 09/04
09/01 - 09/04



Atego (LKN)
Axor

01/98 - 09/04
09/01 - 09/04

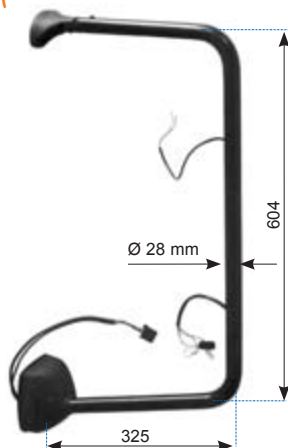

MERCEDES

379 379-1	V [e1] 02★0464		ABS	
	V [E1] 010464			
	V [e1] 03★0013			

MEKRA	Beschreibung description descripción descrizione descripción Benämning Pöpsis özetleik	 mm	OE

*Atego (LKN) 01/98 - 09/04
Axor 09/01 - 09/04*



579	V [e1] 03★0109		ABS	

MEKRA	Beschreibung description descripción descrizione descripción Benämning Pöpsis özetleik	 mm	OE

*Atego (LKN) 10/04 - 05/07
Axor 10/05 - 05/07*



MERCEDES

MERCEDES

Atego II (LKN)
Axor II

10/04
10/04



575	II (E1) 021144		ABS	Ø 28 mm
	<i>Beschreibung</i> <i>description</i> <i>descripcão</i> <i>descripcione</i> <i>descripcion</i> <i>Берылішнік</i> <i>Popis</i> <i>описание</i> <i>özellik</i>			
51.5750.003.099		435 x 215 x 129	000 810 17 79	
51.5750.001.099		435 x 215 x 129	000 810 18 79	
51.5750.004.099		435 x 215 x 129	000 810 14 79	
51.5750.002.099		435 x 215 x 129	000 810 15 79	
15.5750.840H		431 x 186 x 15	001 811 99 33	
19.5750.011.099		431 x 186 x 15	002 811 46 33	
61.5750.100H		435 x 215 x 125	000 811 20 07	
09.5750.001.099			000 820 27 13	

Atego II (LKN)
Axor II

10/04
10/04



577	IV (E1) 03★0003		ABS	Ø 28 mm
	<i>Beschreibung</i> <i>description</i> <i>descripcão</i> <i>descripcione</i> <i>descripcion</i> <i>Берылішнік</i> <i>Popis</i> <i>описание</i> <i>özellik</i>			
51.5770.001.099		215 x 199 x 129	000 810 16 79	
15.5770.870H		192 x 186 x 15	002 811 00 33	
19.5770.311.099		192 x 186 x 15	002 811 47 33	
61.5750.100H		435 x 215 x 125	000 811 20 07	
09.5750.220.099			000 820 28 13	

Atego II (LKN)
Axor II

10/04
10/04
07/10

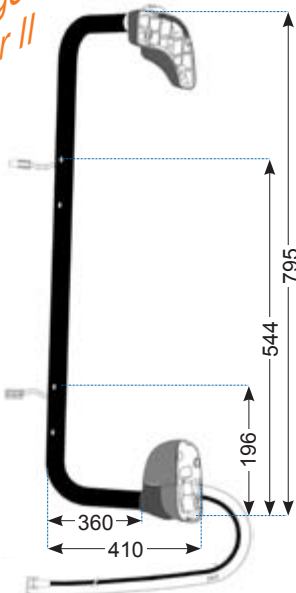

575			Ø 28 mm
	<i>Beschreibung</i> <i>description</i> <i>descripcão</i> <i>descripcione</i> <i>descripcion</i> <i>Берылішнік</i> <i>Popis</i> <i>описание</i> <i>özellik</i>		
58.5752.100H		795 x 410 x 28 Ø	001 810 97 14
58.5752.200H		795 x 410 x 28 Ø	001 810 98 14
58.5752.300H		795 x 410 x 28 Ø	001 810 99 14
58.5752.400E		795 x 410 x 28 Ø	002 810 00 14
58.5750.005.099		795 x 410 x 28 Ø	002 810 64 14
58.5750.006.099		795 x 410 x 28 Ø	002 810 66 14
58.5750.012.099		795 x 410 x 28 Ø	002 810 54 14
58.5750.013.099		795 x 410 x 28 Ø	002 810 59 14
58.5750.015.099		795 x 410 x 28 Ø	002 810 56 14

MERCEDES

379 379-1	V [e1] 02★0464		ABS	
	V [E] 010464			
	V [e1] 03★0013			

MEKRA	Beschreibung description descripción descrizione descripción Benämning Põppis описаније özellik		OE

59.3792.127H		310 x 170 x 83	941 810 10 16 + 941 810 21 16
15.3794.410H		310 x 170 x 15	001 811 22 33
59.3793.127H		310 x 170 x 83	940 810 26 16
15.3791.470H		310 x 170 x 15	002 811 03 33
20.3790.500		116	000 811 04 96

Atego II (LKN) 10/04 - 05/07
Axor II 10/04 - 05/07



579	V [e1] 03★0109		ABS	

MEKRA	Beschreibung description descripción descrizione descripción Benämning Põppis описаније özellik		OE

59.5790.110H		303 x 163	002 810 08 16
15.5791.470H		303 x 163	002 811 22 33

Atego II (LKN) 06/07
Axor II 06/07



MERCEDES

MERCEDES

396 VI e1 03★0017 **INTEGR.**

MEKRA Beschreibung description descripción descripción Benamning Описание Означення mm **OE**

*Atego (LKN) / Axor 01/98 - 09/04
 Atego II / Axor II 10/04
 Actros (SKL) 09/96 - 09/04
 Actros II 10/04*

1	59.3962.210H		24 V	1261 x 303	973 810 73 16
	59.3961.310H		24 V	1261 x 303	973 810 74 16
2	59.3964.210H		24 V	1145 x 265	940 810 55 16
	59.3964.310H		24 V	1145 x 265	940 810 56 16
3	59.3965.210H		24 V	1219 x 303	943 810 47 16
	59.3965.310H		24 V	1219 x 303	943 810 48 16
1	56.3960.148H		24 V	130 x 250 ø	
3	56.3962.127H			85 x 250 ø	000 810 08 79
	15.3961.174H		24 V	250 x 45	001 811 69 33
	61.3780.100H			74 x 65 x 14	000 811 13 07

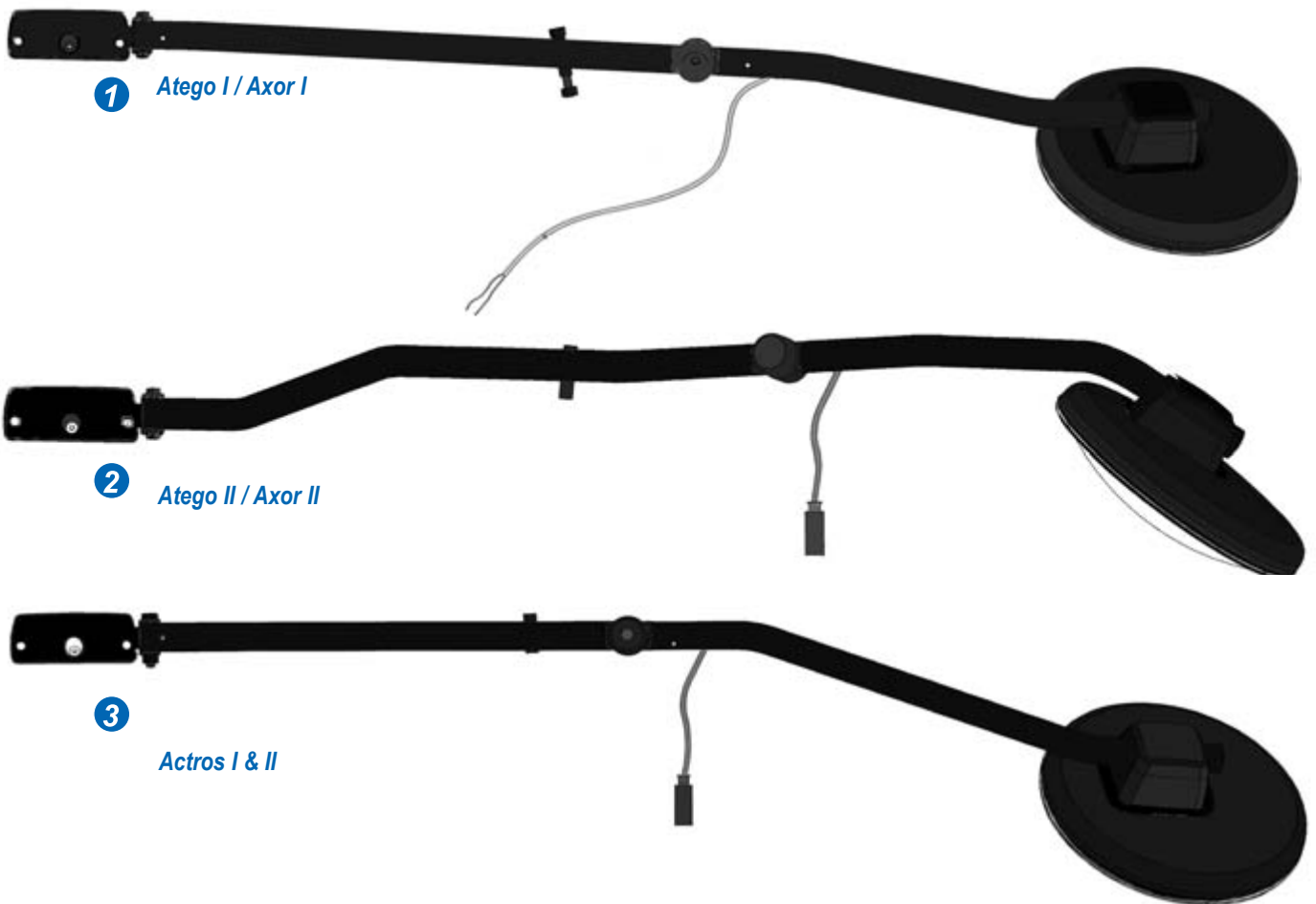

MERCEDES

MERCEDES

1012



MEKRA

Beschreibung
description
descripção
descripción
Beschreibung
Benamning
Pppis
описаније
őzetlek



OE

1	19.1012.002.099						401 x 200	002 811 33 33
	19.1012.003.099						401 x 200	002 811 34 33

1012



MEKRA

Beschreibung
description
descripção
descripción
Beschreibung
Benamning
Pppis
описаније
őzetlek



OE

2	19.1012.000.099						191 x 193	002 811 37 33
	19.1012.001.099						191 x 193	002 811 38 33

Actros MP3

06/08

NEU
NOUVEAU
NEW



MERCEDES

MERCEDES

EvoBus D 404 07/93 - 08/99



EvoBus D 404 07/93 - 08/99



Connecto C/Ü 1999



366	II e1 02★14121			Ø 28 mm
------------	----------------	--	--	---------

MEKRA	Beschreibung description descripção descripção descripção descripção Bezeichnung põpis описание özellik		
51.3660.147		369 x 184 x 132	000 810 58 16 + 000 810 81 16
40.3665.118F		355 x 170 x 3	000 811 91 33
10.6121.140		340 x 159	000 821 03 29 + 000 821 05 29
51.3660.167		369 x 184 x 132	000 810 60 16 + 000 810 82 16
40.3665.118F		355 x 170 x 3	000 811 91 33
10.6121.140		340 x 159	000 821 03 29 + 000 821 05 29

367	IV e1 02★0394 IV (E1) 010394			Ø 28 mm
------------	---------------------------------	--	--	---------

MEKRA	Beschreibung description descripção descripção descripção descripção Bezeichnung põpis описание özellik		
56.3670.147H		225 x 185 x 129	641 810 46 16 + 000 810 70 16
40.3675.204H		209 x 169 x 3	000 811 85 33 + 001 811 81 33
40.3670.404H		209 x 169 x 3	
10.3670.410H		190 x 150	000 821 02 29 + 000 821 04 29

398	II e1 02★0505 II (E1) 010505			Ø 28 mm
------------	---------------------------------	--	--	---------

MEKRA	Beschreibung description descripção descripção descripção descripção Bezeichnung põpis описание özellik		
1 59.3980.021H		285 x 535 x 125	671 810 09 16
59.3980.022H		285 x 535 x 125	671 810 13 16
2 59.3980.011H		602 x 450 x 168	671 810 07 16
59.3980.012		602 x 450 x 168	671 810 12 16
61.3752.147H		380 x 170 x 68	000 810 02 79
15.3752.470H		380 x 170 x 15	001 811 34 33 + 001 811 73 33
61.3780.100H		74 x 65 x 14	000 811 13 07
61.3752.167H		380 x 170 x 68	000 810 03 79
15.3752.470H		380 x 170 x 15	001 811 34 33 + 001 811 73 33
61.3780.100H		74 x 65 x 14	000 811 13 07
20.2480.211		108 x 50 x 15 / 2500	
20.2480.212		108 x 50 x 15	

MERCEDES

Setra BR 300
1995-02/04

280 II e1 02★14117 II E1 0114117 **INTEGR.**

MEKRA	Beschreibung description descripção descripção descripção Benennung Pppis описание özellik		OE
61.2800.401H		700 x 1000 x 210	8.688.075.000.0
15.2800.480H		409 x 168 x 6	8.688.075.001.0
15.2800.470H		213 x 168 x 7	8.688.075.002.0
11.2800.011			8.688.075.163.0
20.2800.550		160 x 114 x 106	8.688.075.165.0
61.2800.402H		700 x 1000 x 210	8.688.076.000.0
15.2800.480H		409 x 168 x 6	8.688.075.001.0
15.2800.470H		213 x 168 x 7	8.688.075.002.0
11.2800.012			8.688.076.164.0
20.2800.650		160 x 114 x 106	8.688.076.166.0
08.2810.124		134	8.688.075.169.0



273 II e1 02★0620 II E1 010620

II e1 03★0047 II E1 020926

MEKRA	Beschreibung description descripção descripção descripção Benennung Pppis описание özellik		OE
1 59.2730.401		560 x 300 x 170	671 810 16 16
15.3951.174		368 x 174 x 15	629 811 00 33
20.2710.620		124 x 59 x 18/500	671 810 00 95
2 59.2730.402		622 x 736 x 242	671 810 15 16
15.3951.174		368 x 174 x 15	629 811 00 33
15.3951.114		202 x 153 x 15	629 811 01 33
20.2710.620		124 x 59 x 18/500	671 810 00 95



395
399 II e1 02★0620 II E1 010620

II e1 03★0047 II E1 020926

MEKRA	Beschreibung description descripção descripção descripção Benennung Pppis описание özellik		OE
15.3951.114		202 x 153 x 15	629 811 01 33
15.3951.174		368 x 174 x 15	629 811 00 33

Travego
Tourino
Setra TC 400
Multegeo

09/97
10/03
09/99
09/97



MERCEDES

reflecting your visions.



MERCEDES

349
349 TW

II E1 02★0384 II E1 010384
II E1 02★0418 II E1 010418



ABS

① INTEGR.
③ Ø 18 mm

MEKRA

Bezeichnung
description
description
description
description
benamning
popis
описание
özellik



OE

Sprinter (T1N) 01/95 - 09/05



1

1	51.3490.110H		283 x 177 x 80	901 810 01 16 + 901 810 55 16
	15.3491.071H		238 x 142 x 6	001 811 06 33
	51.3490.120H		283 x 177 x 80	901 810 02 16 + 901 810 64 16
	15.3491.072H		238 x 142 x 6	001 811 07 33
	51.3490.112H		283 x 177 x 80	901 810 09 16 + 901 810 57 16
	15.3491.371H		238 x 142 x 6	001 811 05 33
	15.3492.391F		238 x 142 x 6	001 811 51 33
	51.3490.122H		283 x 177 x 80	901 810 10 16 + 901 810 66 16
	15.3491.372H		238 x 142 x 6	001 811 04 33
	15.3492.392F		238 x 142 x 6	001 811 52 33
2	56.3491.110H		175 x 116 x 70	901 810 10 93 + B 66 5603 97
	15.2711.214H		165 x 93 x 15	
	56.3492.110H		175 x 116 x 70	901 810 11 93 + B 66 5603 98
	15.2711.214H		165 x 93 x 15	
3	59.3491.110H		283 x 177 x 80	901 810 25 16 + 901 810 58 16
	15.3491.071H		238 x 142 x 6	001 811 06 33
	59.3491.120H		283 x 177 x 80	901 810 26 16 + 901 810 67 16
	15.3491.072H		238 x 142 x 6	001 811 07 33
	59.3492.110H		283 x 177 x 80	901 810 37 16 + 901 810 61 16
	15.3491.071H		238 x 142 x 6	001 811 06 33
	59.3492.120H		283 x 177 x 80	901 810 38 16 + 901 810 70 16
	15.3491.072H		238 x 142 x 6	001 811 07 33

2



3

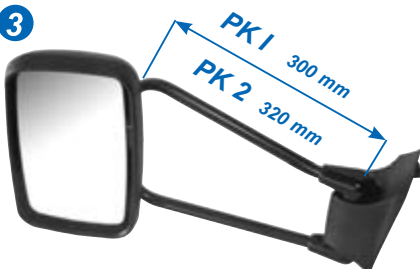

MEKRA
LANG

reflecting your visions.



MERCEDES

589

II III e1 03★0006

II III E1 020902



ABS

INTEGR.

MEKRA

Beschreibung
description
descripção
descripção
description
benimniny
pppis
описаније
özellik



OE

Mercedes Sprinter II
(NCV3) 10/2005

1	51.5891.111H		344 x 318	906 810 48 16
	51.5891.113H		344 x 318	906 810 60 16
	51.5891.311H		344 x 318	906 810 51 16
	51.5891.313H		344 x 318	906 810 63 16
	51.5891.211H		344 x 318	906 810 49 16
	51.5891.213H		344 x 318	906 810 61 16
	51.5891.411H		344 x 318	906 810 50 16
	51.5891.413H		344 x 318	906 810 62 16
	2	51.5892.111H		344 x 450
51.5892.113H			344 x 450	906 810 64 16
51.5892.311H			344 x 450	906 810 55 16
51.5892.313H			344 x 450	906 810 67 16
51.5892.211H			344 x 450	906 810 53 16
51.5892.213H			344 x 450	906 810 65 16
51.5892.411H			344 x 450	906 810 54 16
51.5892.413H			344 x 450	906 810 66 16
3		51.5893.111H		344 x 502
	51.5893.113H		344 x 502	906 810 68 16
	51.5893.311H		344 x 502	906 810 59 16
	51.5893.313H		344 x 502	906 810 71 16
	51.5893.211H		344 x 502	906 810 57 16
	51.5893.213H		344 x 502	906 810 69 16
	51.5893.411H		344 x 502	906 810 58 16
	51.5893.413H		344 x 502	906 810 70 16
	15.5891.741H		236 x 155 x 16	002 811 15 33
15.5891.742H		236 x 155 x 16	002 811 16 33	
15.5891.611H		154 x 59 x 19	002 811 19 33	
15.5891.612H		154 x 59 x 19	002 811 20 33	
08.5891.110			001 822 89 20	
08.5891.111			001 822 93 20	
08.5891.120			001 822 90 20	
08.5891.130			001 822 91 20	
08.5891.140			001 822 92 20	
08.5891.141			001 822 94 20	
08.5890.100			000 820 12 77	
13.5890.120		344 x 201 x 82	001 811 00 22	
13.5890.220		344 x 201 x 82	001 811 01 22	

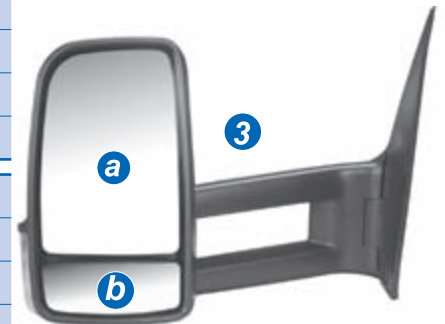
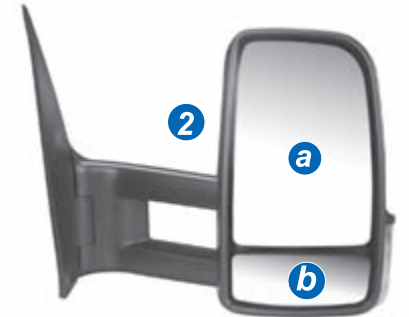

Erhältlich bis Ende 2010
available until end of year 2010
Disponibile jusqu'à fin 2010
disponibile fino alla fine del 2010
disponível até final de 2010
disponibles hasta finales del año 2010
2010 yılı sonuna kadar mevcut
tilgänglich t.o.m. år 2010
K dostáni do konce roku 2010

Varianten ab 2011 siehe Seiten 96-97
versions from year 2011 please see page 96-97
Version 2011, se référer à la page 96-97
versioni dalla 2011, si veda la pagina 96-97
versões a partir de 2011, por favor vá para página 96-97
versiones desde el año 2011 por favor consulte la página 96-97
versiyonları 2011 yılından itibaren.
bkz. sayfa 96-97
versioner fr.o.m. 2011 se sidan 96-97
Varianty od r. 2011 viz. strana 96-97

MERCEDES

reflecting your visions.



MERCEDES

NEU
NOUVEAU
NEW

Mercedes Sprinter II
EURO 5

589

II III e1 03★0006

II III E1 020902



ABS

INTEGR.

MEKRA

Beschreibung
description
description
description
benamning
popis
описаније
описаније





OE



















1	51.5891.111.199		344 x 318	906 810 18 93
	51.5891.112.199		344 x 318	906 810 30 93
	51.5891.113.199		344 x 318	
	51.5891.311.199		344 x 318	906 810 21 93
	51.5891.312.199		344 x 318	906 810 33 93
	51.5891.313.199		344 x 318	
2	51.5892.211.199		344 x 318	906 810 19 93
	51.5892.212.199		344 x 318	906 810 31 93
	51.5892.213.199		344 x 318	
	51.5892.411.199		344 x 318	906 810 20 93
	51.5892.412.199		344 x 318	906 810 32 93
	51.5892.413.199		344 x 318	
3	51.5893.111.199		344 x 450	906 810 22 93
	51.5893.112.199		344 x 450	906 810 34 93
	51.5893.113.199		344 x 450	
	51.5893.311.199		344 x 450	906 810 25 93
	51.5893.312.199		344 x 450	906 810 37 93
	51.5893.313.199		344 x 450	
4	51.5892.211.199		344 x 450	906 810 23 93
	51.5892.212.199		344 x 450	906 810 35 93
	51.5892.213.199		344 x 450	
	51.5892.411.199		344 x 450	906 810 24 93
	51.5892.412.199		344 x 450	906 810 36 93
	51.5892.413.199		344 x 450	
5	51.5893.111.199		344 x 502	906 810 26 93
	51.5893.112.199		344 x 502	906 810 38 93
	51.5893.113.199		344 x 502	
	51.5893.311.199		344 x 502	906 810 29 93
	51.5893.312.199		344 x 502	906 810 41 93
	51.5893.313.199		344 x 502	
6	51.5893.211.199		344 x 502	906 810 27 93
	51.5893.212.199		344 x 502	906 810 39 93
	51.5893.213.199		344 x 502	
	51.5893.411.199		344 x 502	906 810 28 93
	51.5893.412.199		344 x 502	906 810 40 93
	51.5893.413.199		344 x 502	

available from 2010

MERCEDES

589	II III E1 03★0006			INTEGR.
	II III E1 020902			

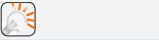
	Beschreibung description descripção descripción Benimining Ppppis онискариве özenlik		

19.5890.411.099		240 x 158 x 21	
19.5890.412.099		240 x 158 x 21	
19.5890.011.099		240 x 158 x 21	002 811 52 33
19.5890.012.099		240 x 158 x 21	002 811 53 33
19.5890.721.099		157 x 65 x 20	
19.5890.722.099		157 x 65 x 20	
19.5890.321.099		157 x 65 x 20	
19.5890.322.099		157 x 65 x 20	
13.5890.120		344 x 201 x 82	001 811 00 22
13.5890.220		344 x 201 x 82	001 811 01 22
08.5891.110			2E0 953 049 A
08.5891.111			2E0 953 049 C
08.5891.120			2E0 953 050 A
08.5891.130			2E0 953 049 B
08.5891.140			2E0 953 050 B
08.5891.141			2E0 953 050 C
08.5890.100			2E0 945 981

*Mercedes Sprinter II
(NCV3)
EURO 5*

**NEU
NOUVEAU
NEW**



available from 2010

MERCEDES

RENAULT

390 II e1 03★0009 II E1 020914 **INTEGR.**
 IV e1 03★0037 IV E1 020916

MEKRA Beschreibung description descripción descripción Benamning Projele Описание Ozemlik mm

Midlum 1818
Premium
Distribution
Kerax

05/2006
05/2006
05/2006



1	59.3901.142H		880 x 340 x 155	74.20.812.551
	59.3901.142H		880 x 340 x 155	50.10.623.225
	59.3901.143H		880 x 340 x 155	50.10.623.689 + 50.10.623.231
	59.3901.143H		880 x 340 x 155	50.10.623.231
2	59.3901.132H		880 x 440 x 155	74.20.812.581
	59.3901.132H		880 x 440 x 155	50.10.623.240
	59.3901.133H		880 x 440 x 155	50.10.623.697 + 50.10.623.246
	59.3901.133H		880 x 440 x 155	50.10.623.246
61.3900.100H		370 x 245 x 105	74.20.862.782	
61.3900.110H		370 x 245 x 105	74.20.866.665	
61.3911.110H		230 x 245 x 105	74.20.862.809	
15.3900.840H		337 x 202	74.20.862.795	
15.3911.871H		197 x 200	74.20.862.810	
08.5751.424E		130	74.20.866.672	
11.3900.200H		370 x 247 x 80	74.20.862.779	
11.3900.201H		370 x 247 x 80	74.20.903.714	
11.3910.200H		244 x 225 x 75	74.20.862.800	
11.3910.201H		244 x 225 x 75	74.20.903.736	
1	58.3900.143H		800 x 270 x 28 ø	74.20.903.722
	58.3900.343H		800 x 270 x 28 ø	74.20.914.884
2	58.3900.133H		800 x 350 x 28 ø	74.20.903.723
	58.3900.333H		800 x 350 x 28 ø	74.20.914.934
	20.3900.510		518 x 98	50.10.623.057
	20.5580.110H		293 x 76	50.10.578.517
	20.5580.130H		293 x 76	74.20.781.812

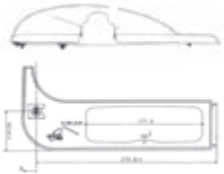
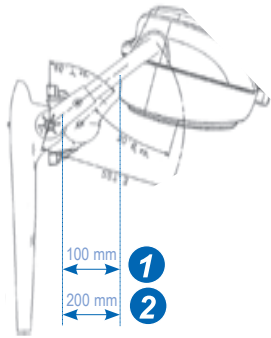

Midlum 1818
Premium
Distribution
Kerax

05/2006
05/2006
05/2006



558 V e1 03★0011

MEKRA Beschreibung description descripción descripción Benamning Projele Описание Ozemlik mm

















59.5580.247H		260 x 229 x 70	50.10.578.511
59.5580.147H		260 x 229 x 70	50.10.578.512

RENAULT

390 II E1 03★0009 II E1 020914 IV E1 03★0037 IV E1 020916  ABS INTEGR.

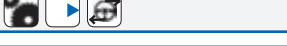
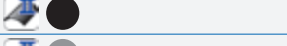
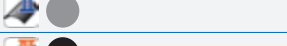
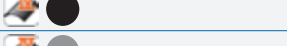
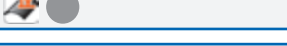
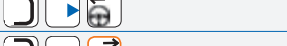
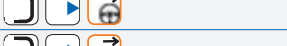
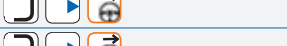
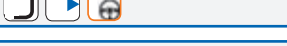
MEKRA *Bezeichnung description description description description description description description description*  mm OE

*Midlum 1818
Premium
Distribution
Kerax*
05/2006 →
05/2006 →
05/2006 →

1	59.3901.242H		880 x 340 x 155	74.20.812.555
	59.3900.242H		880 x 340 x 155	50.10.623.226
	59.3901.243H		880 x 340 x 155	50.10.623.690 + 50.10.623.232
	59.3900.243H		880 x 340 x 155	50.10.623.232
2	59.3901.232H		880 x 440 x 155	74.20.812.580
	59.3900.232H		880 x 440 x 155	50.10.623.241
	59.3901.233H		880 x 440 x 155	50.10.623.698 + 50.10.623.247
	59.3900.233H		880 x 440 x 155	50.10.623.247
	61.3900.100H		370 x 245 x 105	74.20.862.782
	61.3900.120H		370 x 245 x 105	74.20.913.815 + 74.85.120.820
	61.3911.120H		230 x 245 x 105	74.20.862.813
	15.3900.840H		337 x 202	74.20.862.795
	15.3911.872H		197 x 200	74.20.862.815
	08.5751.324E		130	74.20.862.812
	11.3900.200H		370 x 247 x 80	74.20.862.779
	11.3900.201H		370 x 247 x 80	74.20.903.714
	11.3910.200H		244 x 225 x 75	74.20.862.800
	11.3910.201H		244 x 225 x 75	74.20.903.736
1	58.3900.243H		800 x 270 x 28 ø	74.20.903.727
	58.3900.233H		800 x 270 x 28 ø	74.20.903.732
2	58.3900.443H		800 x 350 x 28 ø	74.20.914.885
	58.3900.433H		800 x 350 x 28 ø	74.20.914.938
	20.3900.520H		518 x 98	50.10.623.058
	20.5580.140F		293 x 76	74.20.781.811
	20.5580.120H		293 x 76	50.10.578.518

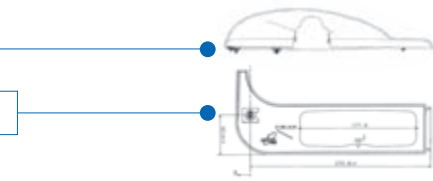

RENAULT

RENAULT

390

 II 03★0009 II 020914
 IV 03★0010 IV 020913

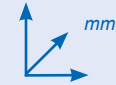

INTEGR.

MEKRA

 Beschreibung
 description
 descrição
 descripción
 description
 benámenning
 popis
 описание
 özetlik

OE

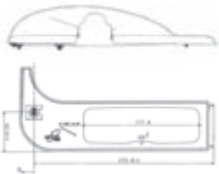
Premium Route 2711
10/2005



59.3901.123H		880 x 340 x 155	50.10.578.505
59.3900.123H		880 x 340 x 155	50.10.578.503
61.3900.110H		370 x 245 x 105	74.20.866.665
61.3910.110H		300 x 230 x 105	74.20.904.268
15.3900.840H		337 x 202	74.20.862.795
15.3910.871H		203 x 189	74.20.903.745
08.5751.424E		130	74.20.866.672
11.3900.100H		371 x 244 x 80	74.20.903.880
11.3900.101H		371 x 244 x 80	74.20.903.881
11.3910.110H		303 x 244 x 75	74.20.903.882
11.3910.111H		303 x 244 x 75	74.20.903.885
58.3900.143H		800 x 270 x 28 ø	74.20.903.722
58.3900.343H		800 x 270 x 28 ø	74.20.914.884
20.3900.510		518 x 98	50.10.623.057
20.5580.110H		293 x 76	50.10.578.517
20.5580.130H		293 x 76	74.20.781.812

558

 V 03★0011
 V 020912

MEKRA

 Beschreibung
 description
 descrição
 descripción
 description
 benámenning
 popis
 описание
 özetlik



OE















Premium Route 2711
10/2005

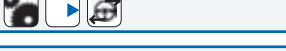

59.5580.247H		260 x 229 x 70	50.10.578.511
59.5580.147H		260 x 229 x 70	50.10.578.512

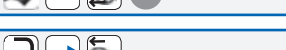
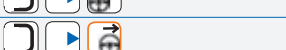
RENAULT





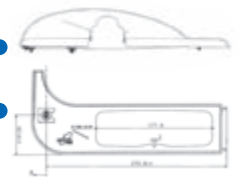

390 II [e1] 03★0009 II (E1) 020914 IV [e1] 03★0010 IV (E1) 020913   **INTEGR.**

MEKRA	Beschreibung description descripção descripción benymining описаније описаније	mm	OE
59.3901.223H		880 x 340 x 155	50.10.578.506
59.3900.223H		880 x 340 x 155	50.10.578.504
61.3900.120H		370 x 245 x 105	74.20.913.815 + 74.85.120.820
61.3910.120H		300 x 230 x 150	74.20.904.269
15.3900.840H		337 x 202	74.20.862.795
15.3910.872H		203 x 189	74.20.903.746
08.5751.324E		130	74.20.862.812
11.3900.100H		371 x 244 x 80	74.20.903.880
11.3900.101H		371 x 244 x 80	74.20.903.881
11.3910.120H		303 x 244 x 75	74.20.903.883
11.3910.121H		303 x 244 x 75	74.20.903.887
58.3900.243H		800 x 270 x 28 ø	74.20.903.727
58.3900.443H		800 x 350 x 28 ø	74.20.914.885
20.3900.520H	 a	518 x 98	50.10.623.058
20.5580.140F	 b	293 x 76	74.20.781.811
20.5580.120H	 b	293 x 76	50.10.578.518

Premium Route 2711
10/2005

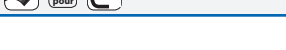

552 V VI [e1] 03★0033 V VI (E1) 020894   **INTEGR.**

MEKRA	Beschreibung description descripção descripción benymining описаније описаније	mm	OE
59.5524.640.099		644 x 319 x 203	74.20.849.852 + 74.82.226.023
51.5524.930H		319 x 187 x 50	74.21.020.285
59.5524.648.099		725 x 319 x 126	74.20.849.837 + 74.82.226.025
51.5524.930H		319 x 187 x 50	74.21.020.285
20.5520.270		448 x 196	
59.5524.649.099		437 x 319 x 103	74.20.849.835 + 74.82.226.027
51.5524.930H		319 x 187 x 50	74.21.020.285
20.5520.260		245 x 259 x 96	

Renault Midlum
& Premium
Kerax Distribution
05/2006 1818

NEU
NOUVEAU
NEW

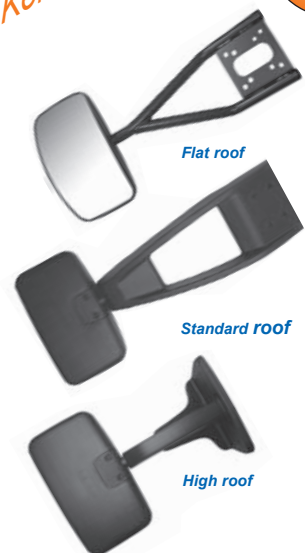

RENAULT

348

ECE



ABS

Ø 22 mm

MEKRA

Beschreibung
 description
 descripción
 descrizione
 descripción
 Beschreibung
 попис
 описаније
 описаније



OE

1	61.3481.149H		395 x 205 x 145	
	15.3480.840H		372 x 189 x 2	
2	61.3480.149H		382 x 193 x 85	50.01.853.675 + 50.01.856.292 50.01.833.026

Premium, Gamme R/G
Midlum / Kerax

→ 09/2005



348

IV e1 03★0185

IV (E1) 021023



ABS

Ø 22 mm

MEKRA

Beschreibung
 description
 descripción
 descrizione
 descripción
 Beschreibung
 попис
 описаније
 описаније



OE

61.3482.149H		199 x 199 x 97	74.21.276.373
40.3485.403E		191 x 191 x 3	

Premium, Gamme R / G
Midlum / Kerax

→ 09/2005



RENAULT

286	II 02★752			INTEGR.
	II 00752			

	Beschreibung description descripção descripção descripção Benennung pppis описание özellik		

51.2860.112H		480 x 240 x 90	50.01.838.475
15.2860.880H		482 x 205	50.00.289.377

51.2860.212H		480 x 240 x 90	50.01.842.202
15.2860.880H		482 x 205	50.00.289.377

51.2860.001.099			50.01.873.670
51.2860.002.099			50.01.873.671

287	IV / V 00753			INTEGR.
	VI 03★0042			
	V 03★0044			

	Beschreibung description descripção descripção descripção Benennung pppis описание özellik		

1	40.2875.404H		200 x 151 x 3	50.00.289.373
----------	--------------	--	---------------	---------------

2	56.2870.140H		240 x 215 x 120	50.01.873.672
	56.2870.130H		240 x 215 x 120	50.01.873.673

288	VI 03★0042			INTEGR.
	V 03★0044			

	Beschreibung description descripção descripção descripção Benennung pppis описание özellik		

59.2880.130H		310 x 215 x 140	50.10.646.159
--------------	--	-----------------	---------------

552	V VI 03★0033			INTEGR.
	V VI 020894			

	Beschreibung description descripção descripção descripção Benennung pppis описание özellik		

59.5524.748.099			74.20.849.799 ÷ 74.82.265.705
-----------------	--	--	-------------------------------

51.5524.930H		319 x 187 x 50	74.21.020.285
--------------	--	----------------	---------------

20.5520.250			74.20.850.409 ÷ 74.21.346.867
-------------	--	--	-------------------------------

552	V VI 03★0033			INTEGR.
	V VI 020894			

	Beschreibung description descripção descripção descripção Benennung pppis описание özellik		

59.5524.730.099			
-----------------	--	--	--

51.5524.930H		319 x 187 x 50	74.21.020.285
--------------	--	----------------	---------------



Magnum

02/92



Magnum

02/92

NEU NOUVEAU NEW



Magnum

02/92

NEU NOUVEAU NEW



Magnum

1992 -> 1998

1998

NEU NOUVEAU NEW

RENAULT

SCANIA

alte Baureihe / old series → 10/81



R 93, R 113, R 143
10/81 - 1996



R 93, R 113, R 143
10/81 - 1996



R 93, R 113, R 143
124/144 (Serie 400)
1996 - 07/04



259	II E4 02★2069			Ø 16-18 mm
	II E4 012060			

MEKRA	Beschreibung description descripción descricao descripció descripcione descripcion benamning popis описание czeskaik		
40.2590.114H		257 x 155 x 3	176 297

257	II E1 01★14059			Ø 22 mm

MEKRA	Beschreibung description descripción descricao descripció descripcione descripcion benamning popis описание czeskaik		
40.2570.222H		417 x 221 x 3	296 538
11.2570.100		404 x 206 x 120	396 856

51.2576.147H		426 x 231 x 75	110 6955 + 356 495 316 624 + 367 624
40.2570.422H		417 x 221 x 4	296 538 + 376 243
10.2577.400		315 x 200	
11.2570.100		404 x 206 x 120	396 856

156/6 BO	IV E5 02★0003			① Ø 22 mm ② Ø 16-20 mm
	IV E5 01019			

MEKRA	Beschreibung description descripción descricao descripció descripcione descripcion benamning popis описание czeskaik		
40.1561.105H		253 x 150 x 3	316 918
11.1560.200		235 x 145 x 88	110 6734

20.1560.122H		73 x 58 x 23	316 620
20.1560.116H			

156/6 BO	IV E5 02★0004			
	IV E5 01020			

MEKRA	Beschreibung description descripción descricao descripció descripcione descripcion benamning popis описание czeskaik		
40.1561.105H		253 x 150 x 3	316 918

61.1561.100H		41 x 80 x 20	396 848
21.1560.100		235 x 16 ø	



SCANIA

400				INTEGR.
------------	--	--	--	----------------

	Beschreibung description descripção descripción benamning popis описаније описаније		
--	--	--	--

II	15.4001.110H		432 x 200 x 18	134 6377 ♦ 144 2706
	15.4002.110H		432 x 200 x 18	134 6378 ♦ 144 2705 173 2776 ♦ 139 6501 139 6503 ♦ 139 6512 139 6514
	15.4001.840H		432 x 200 x 20	176 5985
IV	15.4002.114H		184 x 160 x 18	144 3864 ♦ 134 6579 173 2778 ♦ 134 6382 173 2782 ♦ 173 2783
	15.4001.740H		184 x 160 x 20	176 7265

558	V 03★0011 V 020912			
------------	-------------------------	--	--	--

	Beschreibung description descripção descripción benamning popis описаније описаније		
--	--	--	--

59.5581.100H		260 x 229 x 77	
---------------------	--	----------------	--

552 552-1	V 02★0742 V 010742 V 03★0033 V 020894			
----------------------------	--	--	--	--

	Beschreibung description descripção descripción benamning popis описаније описаније		
--	--	--	--

59.5520.040H		319 x 187 x 75	150 4678 ♦ 191 2467
59.5520.030H		319 x 187 x 75	175 7155 ♦ 148 4076
59.5520.050H		319 x 187 x 75	

552	V VI 03★0033 V VI 020894			INTEGR.
------------	-------------------------------	--	--	----------------

	Beschreibung description descripção descripción benamning popis описаније описаније		
--	--	--	--

1	59.5524.032H			152 2881
	51.5524.930H		319 x 187 x 50	148 4076
	58.5524.020			148 4078
2	59.5524.034H			
	51.5524.930H		319 x 187 x 50	148 4076
	58.5524.021			148 4079



124 / 144 (Serie 400)
1996 - 07/04
08/04

Serie 4 R / P / T



Komplettspiegel erhält-
lich bei SCANIA
complete mirror
available at SCANIA

124 / 144 (Serie 400)
1996 - 07/04

Serie 4 R / P / T



Serie 4 R / P / T



Serie R / P / T
440 - 470 - 500 - 620



bei SCANIA erhältlich
available at SCANIA
disponible à SCANIA
disponível para SCANIA
ottenibile da SCANIA
tilgjengelig hos SCANIA
k dostání u SCANIA
имається в SCANIA
SCANIA'da bulunabilir

VOLVO

255	II e1 01★14071			Ø 16-18 mm
	Beschreibung description description description description Бергаппинг popis описание özellik			
51.2550.127H		315 x 224 x 27	3520 26 ÷ 1100 7006	
40.2550.222H		298 x 208 x 3	3525 07 ÷ 1199 4438	

N-Serie
F 86, F 88, F 89
12/77 - 08/85
08/65 - 06/77



F 7, F 10, F 12
12/77 - 08/85



FL 4, FL 6



250	II e1 01★14002			Ø 14-20 mm
	Beschreibung description description description description Бергаппинг popis описание özellik			
51.2500.127H		375 x 183 x 26	1581 550	
40.2500.222H		366 x 176 x 3	1581 599	
51.2500.147H		375 x 183 x 26	1594 412 ÷ 1581 616 1594 411	
40.2500.422H		366 x 176 x 3	1581 602 ÷ 1594 415	
10.6121.100		340 x 159		
09.2070.101H		2070		

253	II e1 02★14067 II (E1) 0114067			Ø 18 mm
	Beschreibung description description description description Бергаппинг popis описание özellik			
51.2530.120H		370 x 182 x 64	6793 879	
40.2530.222H		356 x 170 x 3	1697 926	
61.2530.110H		55 x 43 x 36	1697 928	
51.2530.140H		370 x 182 x 64	6793 880	
40.2530.422H		356 x 170 x 3	1697 926 + 3090 006 ÷ 3098 469	
10.6121.140		340 x 159	3090 006	
09.2070.101H		2070		
61.2530.110H		55 x 43 x 36	1697 928	

VOLVO

252	II (E1) 02★14089			Ø 14-20 mm
	II (E1) 0114089			

MEKRA	Beschreibung description descripción descrizione descripción Benämning popis описаније ozeilnik		OE

51.2520.127H		444 x 208 x 84	1599 462 ♦ 3090 395
40.2520.222H		429 x 194 x 3	1697 007 ♦ 2085 4576

51.2520.147H		444 x 208 x 84	1594 902 ♦ 1621 353 1195 934 ♦ 3090 396
40.2520.422H		429 x 194 x 3	1697 008 ♦ 3093 519

10.6421.140		400 x 176	
-------------	--	-----------	--

09.2070.101H		2070	
--------------	--	------	--

FL 4, FL 6, FL 7, FL 10
 F 10, F 12, F 16 09/85 - 9/94
 NL 10, NL 12 09/85 - 9/93
 1972 - 8/85



261	IV e6 02★6565			Ø 14-20 mm

MEKRA	Beschreibung description descripción descrizione descripción Benämning popis описаније ozeilnik		OE

56.2610.127H		230 x 230 x 100	1618 973 ♦ 2085 4621
40.2615.204		215 x 215 x 3	1697 984 ♦ 1697 862

56.2610.147H		230 x 230 x 100	1618 769 ♦ 1621 354 2085 4626
40.2615.204		215 x 215 x 3	1697 984 ♦ 1697 862

FL 4, FL 6, FL 7, FL 10
 F 10, F 12, F 16 09/85 - 9/94
 NL 10, NL 12 09/85 - 9/93
 1972 - 8/85



156/6 BO	V (e5) 02★0004			
	V (E5) 01020			

MEKRA	Beschreibung description descripción descrizione descripción Benämning popis описаније ozeilnik		OE

56.1561.110H		258 x 152 x 30	1622 446
40.1561.105H		253 x 150 x 3	1697 679 ♦ 3093 519

61.1561.100H		41 x 80 x 20	
--------------	--	--------------	--

FL 4, FL 6, FL 7, FL 10
 F 10, F 12, F 16 09/85 - 9/94
 NL 10, NL 12 09/85 - 9/93
 1972 - 8/85



VOLVO

10/93 - 03/02
08/98 - 03/02
05/99 →

FH
FM
NH



370		II e1 02★14125 II E1 0114125		Truck II	ABS	INTEGR.
MEKRA		Beschreibung description descripção descripção descripção benamning popis описаније описаније		mm		OE
59.3702.231H		469 x 440 x 117	3980 924			
59.3702.431H		469 x 440 x 117	3980 926			
61.3700.231H		469 x 249 x 117	3091 256			
61.3700.241H		469 x 249 x 117	3091 257			
58.3701.130H		240 x 250 x 45	3091 750			
58.3701.140H		240 x 250 x 45	3091 751			
08.3700.326H		70 x 50 x 73	3092 040			
15.3702.470H		433 x 198 x 16	3090 737* 3091 756 3092 854* 2085 4564			
15.3702.170H		433 x 198 x 16	3090 736* 2085 4555			

10/93 - 03/02
08/98 - 03/02
05/99 →

FH
FM
NH



371		II e1 02★14126 II E1 0114126 IV e1 02★11016 IV E1 0111016		Truck II + IV	ABS	INTEGR.
MEKRA		Beschreibung description descripção descripção descripção benamning popis описаније описаније		mm		OE
59.3712.241H		665 x 443 x 117	3980 933			
51.3712.241E		665 x 251 x 117				
61.3710.241H		665 x 251 x 117	3091 259			
61.3710.231H		665 x 251 x 117	3091 258			
58.3701.130H		240 x 250 x 45	3091 750			
58.3701.140H		240 x 250 x 45	3091 751			
08.3700.326H		70 x 50 x 73	3092 040			
II 15.3702.470H		433 x 198 x 16	3090 737* 3091 756 3092 854* 2085 4564			
15.3702.170H		433 x 198 x 16	3090 736* 2085 4555			
IV 15.3712.410H		181 x 175 x 24	3090 739* 3091 757 2085 4568			
15.3712.110H		181 x 175 x 24	3090 738			
15.3712.870H		181 x 175 x 27	2120 3311			

* 2 Stück erforderlich für vertikale und horizontale Verstellung
2 units necessary for vertical and horizontal adjustment
2 moteurs sont nécessaires pour le réglage vertical et horizontal
são necessárias 2 unidades para ajuste vertical e horizontal
sono necessari due pezzi per la regolazione verticale ed orizzontale

* son necesarias dos unidades para el ajuste vertical y horizontal
2 enheter nödvändiga för horisontal-vertikal styrning
2 kusy (motorky) nutné pro vertikální a horizontální natáčení
необходимы два механизма для вертикального и
горизонтального переставления
düşey ve yatay ayarlarla yapabilmek için 2 adet gereklidir

VOLVO

360 360-1	V [E1] 02★12013	V [E1] 0112013			INTEGR.
	V [E1] 02★0039	V [E1] 020973			

	Beschreibung description descripción descrizione Benämning Põppis otkraskivne ozenlik		

1	59.3601.128H		284 x 174 x 62	1096 643
	40.3605.204		272 x 162 x 3	3090 734
	59.3601.178H		284 x 174 x 64	2120 3313
	40.3605.203H		272 x 162 x 3	
	59.3601.188H		284 x 174 x 64	
	40.3605.403H		272 x 162 x 3	
2	59.3602.128H		284 x 174 x 62	3126 117
	40.3605.204		272 x 162 x 3	3090 734
	59.3602.189		284 x 174 x 64	
3	59.3604.178H		284 x 174 x 64	
	40.3605.403H		272 x 162 x 3	

10/93 - 03/02
08/98 - 03/02
05/99 →

FH
FM
NH



VOLVO

VOLVO

390	II e1 03★0009	II E1 020914		ABS	INTEGR.
	IV e1 03★0037	IV E1 020916			

MEKRA	Beschreibung description descripção descripção descripção benamning попис описаније özellik		OE
--------------	---	--	-----------

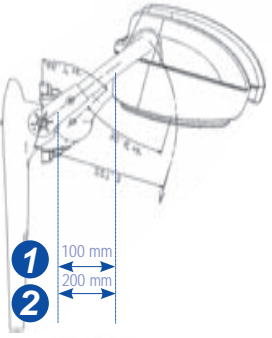

1	59.3900.142H		880 x 340 x 155	2070 7885
	59.3900.143H		880 x 340 x 155	2020 7881 ♦ 2070 7881 2090 3722
2	59.3900.132H		880 x 440 x 155	2070 7876
	59.3900.133H		880 x 440 x 155	2070 7874
	61.3900.100H		370 x 245 x 105	2086 2782
	61.3900.110H		370 x 245 x 105	2086 6665
	61.3911.110H		230 x 245 x 105	2086 2809
	15.3900.840H		337 x 202	2086 2795
	15.3911.871H		197 x 200	2086 2810
	08.5751.424E		130	2086 6672
	11.3900.200H		370 x 247 x 80	2086 2779
	11.3910.200H		244 x 225 x 75	2086 2800
1	58.3900.143H		800 x 270 x 28 ø	2090 3727 ♦ 2090 3722
	58.3900.343H		800 x 270 x 28 ø	2091 4884
2	58.3900.133H		800 x 350 x 28 ø	2090 3723
	58.3900.333H		800 x 350 x 28 ø	2091 4934
	20.3900.510		518 x 98	2070 8110
	20.5580.110H		293 x 76	2070 7813
	20.5580.130H		293 x 76	2078 1812

VOLVO



558	V e1 03★0011	V E1 020912		ABS	

MEKRA	Beschreibung description descripção descripção descripção benamning попис описаније özellik		OE
--------------	---	--	-----------

	59.5580.247H		260 x 229 x 70	2070 7812
	59.5580.147H		260 x 229 x 70	2070 7814

VOLVO

390 II e1 03★0009 II E1 020914 I+IV Truck ABS INTEGR.
 IV e1 03★0037 IV E1 020916

MEKRA Beschreibung description descripción descripción Denominación Põppis otkrivačivye ozeniki mm OE

1	59.3900.242H		880 x 340 x 155	2132 6524 ♦ 2070 8293
	59.3900.243H		880 x 340 x 155	2074 3983
2	59.3900.232H		880 x 440 x 155	2076 0960
	59.3900.233H		880 x 440 x 155	2070 8303
	61.3900.100H		370 x 245 x 105	2086 2782
	61.3900.120H		370 x 245 x 105	
	61.3911.120H		230 x 245 x 105	2086 2813
	15.3900.840H		337 x 202	2086 2795
	15.3911.872H		197 x 200	2086 2815
	08.5751.324E		130	2086 2812
	11.3900.200H		370 x 247 x 80	2086 2779
	11.3910.200H		244 x 225 x 75	2086 2800
1	58.3900.243H		800 x 270 x 28 ø	2090 3727
	58.3900.233H		800 x 270 x 28 ø	2090 3732
2	58.3900.443H		800 x 350 x 28 ø	2091 4885
	58.3900.433H		800 x 350 x 28 ø	2091 4938
	20.3900.520H		518 x 98	2070 8230
	20.5580.140F		293 x 76	2078 1811
	20.5580.120H		293 x 76	2070 7815



552 V VI e1 03★0033 V VI E1 020894 VI Truck ABS INTEGR.

MEKRA Beschreibung description descripción descripción Denominación Põppis otkrivačivye ozeniki mm OE

	59.5524.638H		725 x 319 x 126	
	51.5524.930H		319 x 187 x 50	
	20.5520.270		448 x 196	



VOLVO

NEU
NOUVEAU
NEW

04/02
04/02

FH II
FM II



NEU
NOUVEAU
NEW

04/02
04/02

FH II
FM II



NEU
NOUVEAU
NEW

04/02
04/02

FH II
FM II



224	IV e11 03★0003	IV E11 026209		ABS	INTEGR.
	IV e11 03★6209	IV E11 030003			
	IV e22 03★629	IV E22 026209			

MEKRA	Beschreibung description description description description Benennung Poppis описаније özellik		OE

II + IV	59.2242.300H		670 x 420 x 110	2056 7633 + 2045 5982 + 2074 6401 + 2056 7670 + 2093 6169
	59.2242.400H		670 x 420 x 110	2056 7635 + 2045 5981 + 2074 6401 + 2056 7670 + 2093 6170

II	59.2242.301.099		670 x 260	2056 7633
	59.2242.401.099		670 x 260	2076 7635
	15.2240.840H		200 x 435	2056 7670 + 2132 0383
	20.2240.001.099			2074 6401
	08.2240.002.099			2093 6169
	08.2240.001.099			2093 6170
	14.2240.001.099			2045 5982
	14.2240.002.099			2045 5981

IV	56.2240.140H		200 x 250 x 70	2084 1081 + 2036 0811 + 2107 0768
	56.2241.140H		200 x 250 x 70	2084 1078 + 2036 0811 + 2107 0768
	15.2242.870H		176 x 188	2107 0768 + 2132 0365
	20.2240.002.099		235 x 210	2036 0811
	56.2240.141.099		200 x 250 x 70	2084 1081
	56.2241.141.099		200 x 250 x 70	2084 1078

224	ECE		INTEGR.	

MEKRA	Beschreibung description description description description Benennung Poppis описаније özellik		OE

56.2240.001.099		290 x 170	2071 6739
-----------------	--	-----------	-----------

224	VI e11 03★0005		ABS	INTEGR.
	VI E11 02★0005			

MEKRA	Beschreibung description description description description Benennung Poppis описаније özellik		OE

59.2240.001.099			2115 1132 + 2071 6956
59.2240.002.099			2115 1129 + 2071 6956

VOLVO

	Beschreibung description descripción descrizione descripción Benämning Põhiss описаније oazeilik					
39.3730.210H			373 x 190 x 3	1699 014	1699 919	
39.3730.410H			373 x 190 x 3	1699 015	1699 011	
10.6121.160			340 x 159	3090 011		



	Beschreibung description descripción descrizione descripción Benämning Põhiss описаније oazeilik					
39.1900.210			193 x 156 x 3	1699 016	1699 012	
39.1900.410H			193 x 156 x 3	1699 017	1699 013	
10.6321.160			186 x 130			



VOLVO

7500 DD, 7700, 8700 City Bus,
9300, 9700, Interreggio, Low
Entry

271	II E1 02★0524	II E1 010524		INTEGR.
	II E1 03★0022	II E1 020905		
	II E1 02★0423	II E1 010423		
	II E1 03★0088	II E1 020923		

	Bezeichnung description description description benämning ррпис описаније описаније		

1	59.2710.401H		703 x 783 x 212	53-707213-710401 + 1251 2005 2052 3877 + 7032 8278 7036 0539 + 8350 042502
	51.3731.326		384 x 205 x 116	7030 9627 + 53-707127-731326 8706 2719 00059 + 8350 035653 VG 10035 001 + 1905 50300
	15.3731.470H		368 x 189 x 40	8350 039047 + 8350 046552
	15.2711.114		165 x 93	7033 1011
	11.3730.210H		367 x 187 x 60	7036 0533 + 8350 046555 8706 2719 000525 + 1251 2040 53-707213-010524
	20.2480.216H		108 x 50 x 15 / 2000	7033 1124 + 8350 046971 7034 8002 + 53-750610-208091
	2	59.2710.402H		701 x 641 x 200
51.3732.326H			384 x 205 x 116	7030 9628 + 1905 50200 VG 10035 002 + 8350 035654 8706 2719 00060 + 8706 2719 00025 53-707127-732346
15.3731.470H			368 x 189 x 40	8350 039047 + 8350 046552
15.2711.114			165 x 93	7033 1011
15.2712.114			152 x 128	
11.3730.210H			367 x 187 x 60	7036 0533 + 8350 046555 8706 2719 000525 + 1251 2040 53-707213-010524
20.2480.217H			108 x 50 x 15 / 5000	7033 1123 + 8350 046432 8706 2719 00018 + 53-707213-480217
20.2710.111H		a	183 x 145 x 107	7033 1122 + 8350 046970 8706 2719 00020 + 53-707213-710111
20.2710.121		a	183 x 145 x 107	7033 1121 + 8706 2719 00019
20.2710.200H		b	183 x 181 x 84	7036 0530 + 7034 8006 8706 2719 00017 + 53-707213-710200

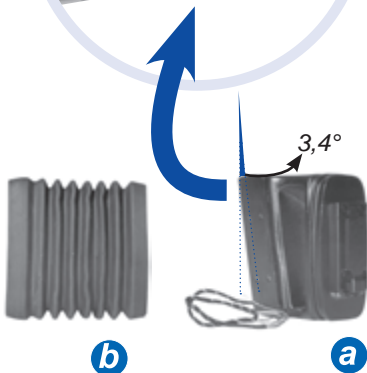

VOLVO

274 II **e1** 03★0082 II **E1** 020910 **INTEGR.**

MEKRA Beschreibung description descripción descripción Benämning Ppplis oivikarivie özetlik **OE**

*Volvo 8300 09/2004 →
 Marco Polo Andare / Taseco 03/2002 →
 Carthago „Chic I“; Opus 10/2006 →
 Sitcar, Carthago*

1	59.2743.322		809 x 620 x 224	
	59.2743.323		809 x 620 x 224	
2	59.2743.332		809 x 720 x 224	
	59.2743.333		809 x 720 x 224	
	15.3702.770F		433 x 198 x 16	
	15.3702.470H		433 x 198 x 16	3090 737 + 3091 756 3092 854 + 2085 4564
	20.2710.111H		183 x 145 x 107	7033 1122 + 8350 046970 8706 2719 00020 + 53-707213-710111
	20.2710.121		183 x 145 x 107	7033 1121 + 8706 2719 00019
	20.2710.620		124 x 59 x 18 / 500	7033 1941
	20.2710.630H		124 x 59 x 18 / 2500	
	20.2710.200H		183 x 181 x 84	7036 0530 + 7034 8006 8706 2719 00017 + 53-707213-710200
	08.3200.233H		42 x 42 x 54	2092 5244 + 7031 0152
	09.3200.220		1000	8350 035655 + 8706 2719 00021

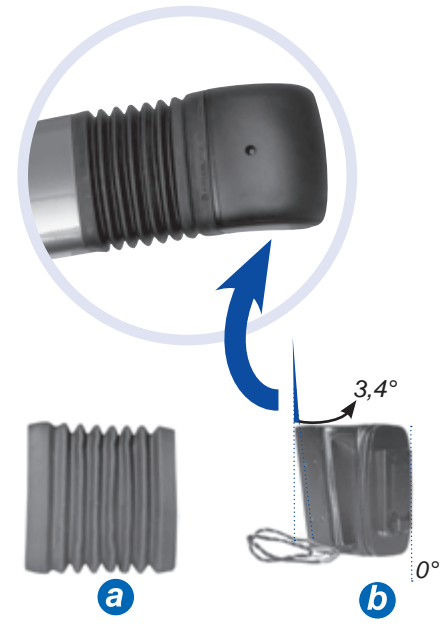
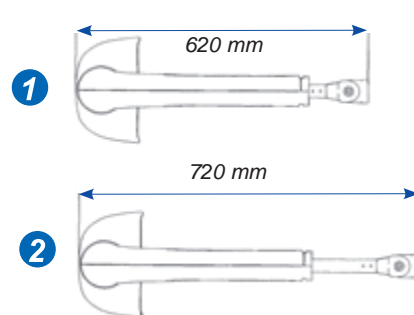



Bully 05/79 - 07/92



Transporter (T4) 07/90



198	III e1 02★0569	ABS	INTEGR.
	III (E1) 010569		

MEKRA	Beschreibung / description / descripción / descrizione / descripción / benaming / popis / описаније / описаније / описаније				mm	OE
	plan	plan	1800	1800		
53.1981.177H					205 x 150 x 40	251 857 513
53.1982.177H					205 x 150 x 40	251 857 514
53.1981.127H					205 x 150 x 40	251 857 513 A
53.1982.127H					205 x 150 x 40	251 857 514 A

196	III e1 02★17324	PC	INTEGR.

MEKRA	Beschreibung / description / descripción / descrizione / descripción / benaming / popis / описаније / описаније / описаније				mm	OE
	plan	plan	1400	12V		
1	53.1960.161H				180 x 230 x 80	701 857 507 F 01C + 701 857 521 J
	15.1962.100H				197 x 157 x 4	701 857 521 J
	15.1962.151H				197 x 157 x 4	701 857 521 H
53.1961.113H					180 x 230 x 80	701 857 507 H + 701 857 521 B
	15.1964.100H				197 x 157 x 4	701 857 521 B + 701 857 513 A
2	53.1961.161H				230 x 180 x 80	701 857 508 F 01C + 701 857 522 L
	15.1962.152H				197 x 157 x 4	701 857 522 L
53.1962.123H					230 x 180 x 80	701 857 508 H + 701 857 522 G
	15.1964.152H				197 x 157 x 4	701 857 522 G



349	II e1 02★0384 II (E1) 010384			INTEGR.
------------	---------------------------------	--	--	----------------

	Beschreibung description descripción descripción descripción Benämning Põppis ohtuavärte özetlik		
--	--	--	--

1	51.3495.110H		283 x 177 x 80	2D1 857 501 A 01C
	15.3491.071H		238 x 142 x 6	2D0 857 521
	51.3495.120H		283 x 177 x 80	2D1 857 502 A 01C
	15.3491.072H		238 x 142 x 6	2D0 857 522
	51.3495.112H		283 x 177 x 80	2D1 857 501 C 01C
	15.3491.371H		238 x 142 x 6	2D0 857 521 A
	15.3492.391F		238 x 142 x 6	
	51.3495.122H		283 x 177 x 80	2D1 857 502 C 01C
	15.3491.372H		238 x 142 x 6	2D0 857 522 A
	15.3492.392F		238 x 142 x 6	
2	56.3491.110H		175 x 116 x 70	
	15.2711.214H		165 x 93 x 15	
	56.3492.110H		175 x 116 x 70	
	15.2711.214H		165 x 93 x 15	



04/75 - 06/96

110	II e4 02★1104 II (E4) 011104			Ø 18 mm
------------	---------------------------------	--	--	----------------

	Beschreibung description descripción descripción descripción Benämning Põppis ohtuavärte özetlik		
--	--	--	--

	51.1100.401H		268 x 165 x 60	
	40.2590.114H*		257 x 155 x 3	



* Nur passend für Spiegel von MEKRA
 only fitting for mirrors of MEKRA
 Se monte uniquement sur des rétroviseurs MEKRA
 solo montaggio per specchi di MEKRA
 montagem aplicada somente à espelhos MEKRA
 muy adecuado para los retrovisores Mekra
 sadece MEKRA aynaları için uyumlu
 passar endast Mekraspeglar
 Vhodné jen pro zrcátka MEKRA



922	III (E1) 021021	ABS	INTEGR.
	III (E1) 010020		

MEKRA	Beschreibung description descripción description description Benamning popis описаније ёзаиклик	mm	OE



1	51.9220.110H		310 x 190 x 100	2K1 857 501 AC 2K1 857 507 9B9 7E1 858 553 9B9 7H1 857 521 7H1 857 527 A 9B9
	15.9220.110H		168 x 185	7H1 857 521
1	51.9221.110H		280 x 220 x 100	2K1 857 501 AE 2K1 857 507 C 9B9 7E1 858 553 9B9 7H1 857 521 A 7H1 857 527 A 9B9
	15.9221.110H		200 x 145	7H1 857 521 A
2	51.9220.220H		310 x 190 x 100	2K1 857 502 AF 2K1 857 508 9B9 7E1 858 554 9B9 7H1 857 552 7H1 857 528 A 9B9
	15.9220.220H		168 x 185	7E1 857 522
2	51.9221.220H		280 x 220 x 100	2K1 857 502 AG 2K1 857 508 C 9B9 7E1 858 554 9B9 7E1 857 522 A 7H1 857 528 A 9B9
	15.9221.220H		200 x 145	7E1 857 522 A

10/2003

923	III (E1) 021021	ABS	INTEGR.
	III (E1) 010020		

MEKRA	Beschreibung description descripción description description Benamning popis описаније ёзаиклик	mm	OE



1	51.9230.110H		310 x 190 x 100	7E1 857 507 9B9 7E1 858 553 9B9 7H1 857 521 7H1 857 527 A 9B9
	15.9220.110H		168 x 185	7H1 857 521
1	51.9231.110H		310 x 190 x 100	7H1 857 507 A 9B9 7E1 858 553 9B9 7H1 857 521 A 7H1 857 527 A 9B9
	15.9221.110H		200 x 145	7H1 857 521 A
2	51.9230.220H		280 x 220 x 100	7E1 857 508 9B9 7E1 858 554 9B9 7E1 857 522 7H1 857 528 A 9B9
	15.9220.220H		168 x 185	7E1 857 522
2	51.9231.220H		280 x 220 x 100	7H1 857 508 A 9B9 7E1 858 554 9B9 7E1 857 522 A 7H1 857 528 A 9B9
	15.9221.220H		200 x 145	7E1 857 522 A



589 II III e1 03★0006 II ABS INTEGR.

II III E1 020902

MEKRA Beschreibung description descripción descripción denominación наименование обозначение mm OE

Volkswagen LT (Crafter) 05/2006

1	51.5891.111H		344 x 318	2E1 857 501 E
	51.5891.113H		344 x 318	2E1 857 501 F
	51.5891.311H		344 x 318	2E2 857 501 C
	51.5891.313H		344 x 318	2E2 857 501 D
	51.5891.211H		344 x 318	2E1 857 502 E
	51.5891.213H		344 x 318	2E1 857 502 F
	51.5891.411H		344 x 318	2E2 857 502 C
	51.5891.413H		344 x 318	2E2 857 502 D
2	51.5892.111H		344 x 450	2E3 857 501 D
	51.5892.113H		344 x 450	2E3 857 501 F
	51.5892.311H		344 x 450	2E4 857 501 D
	51.5892.313H		344 x 450	2E4 857 501 F
	51.5892.211H		344 x 450	2E3 857 502 D
	51.5892.213H		344 x 450	2E3 857 502 F
	51.5892.411H		344 x 450	2E4 857 502 E
	51.5892.413H		344 x 450	2E4 857 502 G
3	51.5893.111H		344 x 502	2E3 857 501 E
	51.5893.113H		344 x 502	2E3 857 501 G
	51.5893.311H		344 x 502	2E4 857 501 E
	51.5893.313H		344 x 502	2E4 857 501 G
	51.5893.211H		344 x 502	2E3 857 502 E
	51.5893.213H		344 x 502	2E3 857 502 G
	51.5893.411H		344 x 502	2E4 857 502 F
	51.5893.413H		344 x 502	2E4 857 502 H
15.5891.741H		236 x 155 x 16	2E1 857 587	
15.5891.742H		236 x 155 x 16	2E1 857 588	
15.5891.611H		154 x 59 x 19	2E1 857 587 A	
15.5891.612H		154 x 59 x 19	2E1 857 588 A	
08.5891.110			2E0 953 049 A	
08.5891.111			2E0 953 049 C	
08.5891.120			2E0 953 050 A	
08.5891.130			2E0 953 049 B	
08.5891.140			2E0 953 050 B	
08.5891.141			2E0 953 050 C	
08.5890.100			2E0 945 981	
13.5890.120		344 x 201 x 82	2E0 857 527	
13.5890.220		344 x 201 x 82	2E0 857 528	



Erhältlich bis Ende 2010
available until end of year 2010
Disponible jusqu'à fin 2010
disponibile fino alla fine del 2010
disponível até final de 2010
disponibles hasta finales del año 2010
2010 yılı sonuna kadar mevcut
tillgänglig t.o.m. år 2010
K dostáni do konce roku 2010

Varianten ab 2011 siehe Seiten 96-97
versions from year 2011 please see page 96-97
Version 2011, se référer à la page 96-97
versioni dalla 2011, si veda la pagina 96-97
versões a partir de 2011, por favor vá para página 96-97
versiones desde el año 2011 por favor consulte la página 96-97
versiyonları 2011 yılından itibaren.
bkz. sayfa 96-97
versioner fr.o.m. 2011 se sidan 96-97
Varianty od r. 2011 viz. strana 96-97



NEU
NOUVEAU
NEW

Volkswagen LT (Crafter)
Euro 5

589 II III e1 03★0006 II III E1 020902 Truck ABS INTEGR.

MEKRA Beschreibung description descrição descrição descripción popis описание özetlik mm OE

1	51.5891.111.199		344 x 318	2E1 857 501 AJ
	51.5891.112.199		344 x 318	2E1 857 501 AM
	51.5891.113.199		344 x 318	2E1 857 501 F
	51.5891.311.199		344 x 318	2E2 857 501 N
	51.5891.312.199		344 x 318	2E2 857 501 P
	51.5891.313.199		344 x 318	2E2 857 501 D
	51.5891.211.199		344 x 318	2E1 857 502 AK
	51.5891.212.199		344 x 318	2E1 857 502 BE
	51.5891.213.199		344 x 318	2E1 857 502 F
	51.5891.411.199		344 x 318	2E2 857 502 N
51.5891.412.199		344 x 318	2E2 857 502 Q	
51.5891.413.199		344 x 318	2E2 857 502 D	
2	51.5892.111.199		344 x 450	2E1 857 501 AK
	51.5892.112.199		344 x 450	2E1 857 501 AN
	51.5892.113.199		344 x 450	2E3 857 501 F
	51.5892.311.199		344 x 450	2E4 857 501 AD
	51.5892.312.199		344 x 450	2E2 857 501 Q
	51.5892.313.199		344 x 450	2E4 857 501 F
	51.5892.211.199		344 x 450	2E1 857 502 AL
	51.5892.212.199		344 x 450	2E1 857 502 AN
	51.5892.213.199		344 x 450	2E3 857 502 F
	51.5892.411.199		344 x 450	2E4 857 502 E
51.5892.412.199		344 x 450	2E2 857 502 R	
51.5892.413.199		344 x 450	2E4 857 502 G	
3	51.5893.111.199		344 x 502	2E1 857 501 AL
	51.5893.112.199		344 x 502	2E1 857 502 AP
	51.5893.113.199		344 x 502	2E3 857 501 G
	51.5893.311.199		344 x 502	2E4 857 501 AE
	51.5893.312.199		344 x 502	2E2 857 501 R
	51.5893.313.199		344 x 502	2E4 857 501 G
	51.5893.211.199		344 x 502	2E1 857 502 AM
	51.5893.212.199		344 x 502	2E1 857 502 AP
	51.5893.213.199		344 x 502	2E3 857 502 G
	51.5893.411.199		344 x 502	2E4 857 502 AE
51.5893.412.199		344 x 502	2E2 857 502 S	
51.5893.413.199		344 x 502	2E4 857 502 H	



available from 2010



589	II III e1 03★0006 II III E1 020902	Truck II ABS	INTEGR.
------------	---------------------------------------	-----------------	---------

MEKRA	Beschreibung description description descripción descrizione Benämning Ppplis описательные ozenlik	mm	OE
-------	--	----	----

19.5890.411.099		240 x 158 x 21	
19.5890.412.099		240 x 158 x 21	
19.5890.011.099		240 x 158 x 21	
19.5890.012.099		240 x 158 x 21	
19.5890.721.099		157 x 65 x 20	
19.5890.722.099		157 x 65 x 20	
19.5890.321.099		157 x 65 x 20	
19.5890.322.099		157 x 65 x 20	
08.5891.110			2E0 953 049 A
08.5891.111			2E0 953 049 C
08.5891.120			2E0 953 050 A
08.5891.130			2E0 953 049 B
08.5891.140			2E0 953 050 B
08.5891.141			2E0 953 050 C
08.5890.100			2E0 945 981
13.5890.120		344 x 201 x 82	2E0 857 527
13.5890.220		344 x 201 x 82	2E0 857 528

Volkswagen LT (Crafter)
Euro 5

NEU
NOUVEAU
NEW



available from 2010



VW

UNIVERSAL







1



2

152 K   Ø 10 -13 mm







1	51.1511.219H			F 182 800 200 570 (Fendt + Agco) + 415 81 08 (Faun) 119 392 + (Fritzmeier) 0 432 5557 (KHD) 043 255 57 (Iveco) 1701 674 M 1 + 684 552 (Massey-Ferguson)
	40.1510.122H		1800	178 x 121 x 2 406 811 00 30 + 319 811 00 30 (Mercedes) 119393 (Fritzmeier)
2	51.1511.119			187 x 130 1-34-677-6541(CNH)
	40.1510.122H		1800	178 x 121 x 2 406 811 00 30 + 319 811 00 30 (Mercedes) 119393 (Fritzmeier)

Steyr Trucks Steyr- + KHD Traktoren



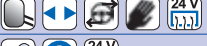

289    Ø 16-18 mm

	51.2890.117H			161 0077 0103 (MAN Steyr) 81.63730-6170 (MAN) G 816 810 150 030 (Fendt + Agco) + 0 432 7533 0 237 6392 (KHD) 023 763 29 (Iveco) 3104 955 M 1 + 3105 215 M 1 (Massey-Ferguson) G 297.810.150.010 (Fendt + Agco)
	40.2890.222H		1800	310 x 220 x 25 300 x 214 x 3
	51.2890.147H			310 x 220 x 25
	40.2890.422H		1800 24V	300 x 214 x 3
	10.6221.100		12 30 W	282 x 162 001 821 00 29 (Mercedes)
	09.2070.101H			2070 161 0077 0009 (MAN Steyr) 81.25432-0149 (MAN) 000 150 55 33 (Mercedes)

242   Ø 18 mm

	51.1520.218H			3570 244 (Volvo) 1891 218 M 91 2942 310 M 91 (Massey-Ferguson) + 321 811 07 30 321 811 06 30 (Mercedes) 81.63730-6099 (MAN) 422 000 85 (Iveco)
	40.1524.115H		1400	265 x 160 x 20 260 x 150 x 3 012 389 67 + 424 844 77 (Iveco) 000 811 10 33 + 321 811 02 33 350 246 90 04 (Mercedes)

UNIVERSAL

UNIVERSAL

153 N				① Ø 10 mm ② Ø 12 mm ③ Ø 14-15 mm ④ Ø 16-18 mm
--------------	--	--	--	--

	Beschreibung description descripción descrição descripción Benamning описаније özellik		
--	---	--	--

51.1531.111H		①	260 x 180 x 20	
51.1531.114H		②	260 x 180 x 20	
51.1531.115H		③	260 x 180 x 20	81.63730-6027 + 81.63730-6297 (MAN) 322 811 00 30 + 329 811 00 30 (Mercedes)
51.1531.118H		④	260 x 180 x 20	
40.4485.114		1400	250 x 170 x 3	81.63733-0012 (MAN) 000 811 06 33 (Mercedes)

152 152 AS			① Ø 10 mm ② Ø 12 mm
-----------------------	--	--	------------------------

	Beschreibung description descripción descrição descripción Benamning описаније özellik		
--	---	--	--

1	51.1520.211H		265 x 160 x 20	264 70 77 (Faun) 81.63730-6007 81.63730-6106 (MAN) 1130 5984 (Volvo) 90002326 (Opel) 072 7836 (Faun) 025 619 31 (Iveco)
	51.1520.212H		265 x 160 x 20	012 389 67 + 424 844 77 (Iveco) 000 811 10 33 + 321 811 02 33 350 246 90 04 (Mercedes)
	40.1524.115H		260 x 150 x 3	1400
2	51.1522.211H		265 x 160 x 20	406 810 52 16 + 406 810 04 16 416 810 00 16 (Mercedes) 1719 728 M 1 (Massey-Ferguson)
	40.1524.115H		260 x 150 x 3	012 389 67 + 424 844 77 (Iveco) 000 811 10 33 + 321 811 02 33 350 246 90 04 (Mercedes)

156/1 BO			Ø 14-20 mm
-----------------	--	--	------------

	Beschreibung description descripción descrição descripción Benamning описаније özellik		
--	---	--	--

56.1523.114H		263 x 150 x 20	
40.1525.108		250 x 140 x 3	800

156 BO			
---------------	--	--	--

	Beschreibung description descripción descrição descripción Benamning описаније özellik		
--	---	--	--

56.1523.117H		263 x 150 x 59	772 31 95 (Faun) + 423 099 19 423 442 19 (Iveco) 000 811 68 33 (Mercedes) F178.810.150.020 (Fendt) 639 153 (Scania)
40.1525.114H		253 x 142	1400
11.1523.310		145 x 55 x 10	



Mercedes Unimog (403 / 408 / 421) 01/77

* Lochabstand
hole distance
entr'axe
distancia entre furos
distanza tra i fori
distancia de agujeros
Hållavstånd
vzdálenost otvorů
расстояние между
отверстиями
delik aralığı



UNIVERSAL

UNIVERSAL

Totewinkelspiegel • dead angle mirror • miroir angle mort • specchio per angolomorto • espejo de ángulo muerto • dödavinkelspegel • zrcadlo mrtvý úhel • зеркала для смертельного угла • ölü nokta aynası



500			PP	
	Beschreibung description description description description benimninyng roplis описание описание		OE	
56.0500.000H		20 x 50 ø	9 982 180 (Hymer)	

750			PP	
	Beschreibung description description description description benimninyng roplis описание описание		OE	
56.0750.000H		20 x 75 ø	9 982 190 (Hymer)	

363	II E1 02★0524 II E1 010524 II E1 03★0022 II E1 010423 II E1 02★0423 II E1 020923 II E1 03★0088 II E1 020905		ABS	Ø 18-26 mm
------------	--	--	-----	------------

	Beschreibung description description description description benimninyng roplis описание описание		OE	
51.3635.201		384 x 205 x 120	290-5544 (Caterpillar)	
51.3636.201		384 x 205 x 120	290-5545 (Caterpillar)	
15.3802.640		368 x 189 x 40		
51.3635.204		384 x 205 x 120	294-1991 (Caterpillar)	
51.3636.204		384 x 205 x 120	294-1992 (Caterpillar)	
15.3802.840H		368 x 189 x 40		
51.3635.206		384 x 205 x 120		
51.3636.206		384 x 205 x 120		
15.3802.840H		368 x 189 x 40		
51.3635.205		384 x 205 x 120		
51.3636.205		384 x 205 x 120		
15.3802.740F		368 x 189 x 40		
11.3730.210H		367 x 187 x 60	84434473 (CNH) ♦ 425 459 90 425 562 27 (Iveco) ♦ 150 5202 (Scania)	

552-1	V VI E1 03★0033 V VI E1 020894		ABS	
--------------	-----------------------------------	--	-----	--

	Beschreibung description description description description benimninyng roplis описание описание		OE	
59.5520.530H		319 x 187 x 75		
59.5520.250H		319 x 187 x 50		
20.5520.100				



Adapter
adaptor
adaptateur
adaptador
adaptér
переходник
adaptör

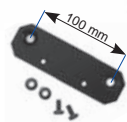

UNIVERSAL

552-1	IV e1 03★0033			INTEGR.	
	IV E1 020894				
	Beschreibung description descripción descrizione descripción Benämning Прпис oželenik				
59.5524.530H		418 x 492			
51.5524.930H		319 x 187 x 50			
61.3890.111H					
51.5524.950F		317 x 187 x 50			
11.5520.401		317 x 187 x 50			

389	VI e1 03★0016			INTEGR.	
	Beschreibung description descripción descrizione descripción Benämning Прпис oželenik				
59.3891.140H		397 x 557			
51.3894.140		259 x 92 ø			
61.3890.111H					
59.3891.150H		397 x 557			
51.3894.160H		251 x 260			
61.3890.113H					

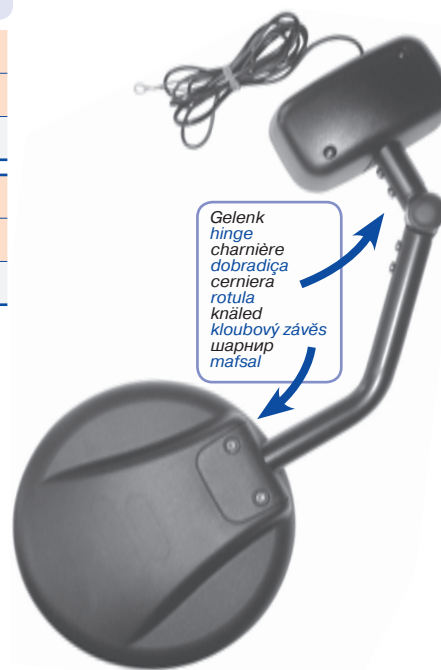
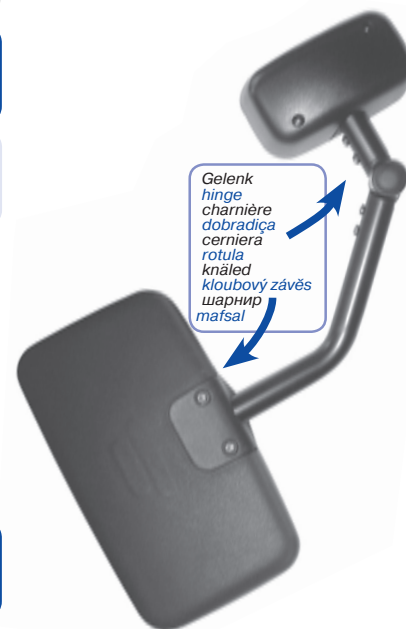

Montagevarianten
mounting possibilities
possibilités de montage
possibilidades de montagem
variante del montaggio
possibilidades de montaje
monteringsmöjligheter
1 06 0 8 4 08
Виды монтажа
montaj montaj olasıllıkları

A Dach
roof
pavillon
teto
techo
techo
tak
střecha automobilu
Крышы автомобиля
kabin üstü

B 4 Vª
A-pillar
montant
pilar A
pilastru A
pilar A
A - stolpe
A - sloupek
A - обр. столб
A - sütunu



UNIVERSAL

NEU
NOUVEAU
NEW

1



2

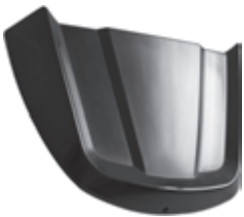

3



NEU
NOUVEAU
NEW



1009



ABS

Ø 18-22 mm

MEKRA

Beschreibung
description
descripción
descricao
descripcion
benamning
popis
описаниє
бэралік

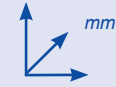

OE

1	51.1009.001.001		291 x 232 x 122
	40.1009.001.000		
	51.1009.009.001		291 x 232 x 122
	40.1009.004.099		
2	51.1009.049.099		190 x 109
	40.1009.002.000		
3	51.1009.170.001		382 x 232 x 122
	40.1009.001.000		
	40.1009.002.000		
	51.1009.025.001		382 x 232 x 122
	40.1009.004.099		
	40.1009.002.000		
	51.1009.033.001		388 x 232
	40.1009.001.000		
	40.1009.003.099		
	51.1009.041.001		388 x 232
	40.1009.004.099		
	40.1009.003.099		
2	51.1009.050.099		190 x 115
	40.1009.003.099		

1010



MEKRA

Beschreibung
description
descripción
descricao
descripcion
benamning
popis
описаниє
бэралік



OE

Artikelnummern auf Anfrage
article numbers on request
Références sur demande
numeri di articolo, su richiesta
número de cadastro sob encomenda
referencias bajo pedido
4 0 - 1 & 7 56 ' ↓
artikelnummer mot förfrågan
Vyrobní čísla na dotaz

5FMTLPQ UBOHF BVG OGBHF
telescope bracket on request
SB T U MTRQV F TVSEFNBCEP
4UBB UFMTRQV TV S DI FUB
SB P UFMTRQV TPCFDPNFOEB
soporte telescópico bajo pedido
6 ' 5 - 12 - - 1. 56 ' ↓
teleskopsarm mot förfrågan
. 5 - 1 - & - & 1

UNIVERSAL

271

II (E) 02★0524 03★0022 02★0423 03★0088
 II (E) 010524 020905 010423 020923



MEKRA

Beschreibung
 description
 descripción
 descripción
 Beschreibung
 ovrskazanie
 ozeanik



OE

*Avtobus, BMC, Concorde,
 Dallavia, EvoBus, Euro Coach,
 Hymet, Ikarbus, Irisbus,
 Marcopolo, MAZ, Plaxton,
 TEMSA, Tovarna, VDL,
 Wrightbus*

59.2710.401H		703 x 783 x 212	AA-01176 PAA-01976 (Plaxton) 284230 (Concorde)
51.3731.326		384 x 205 x 116	50.06.232.483 (Irisbus)
15.3731.470H		368 x 189 x 40	425 562 28 (Iveco) 150 5201 (Scania)
11.3730.210H		367 x 187 x 60	84434473 (CNH) ♦ 425 459 90 425 562 27 (Iveco) 150 5202 (Scania)
20.2480.216H		108 x 50 x 15 / 2000	145 1226 (Scania)
20.2480.217H		108 x 50 x 15 / 5000	425 459 85 (Iveco)
59.2710.411		703 x 788 x 212	71101611 (Irisbus)
51.3731.326		384 x 205 x 116	50.06.232.483 (Irisbus)
15.3731.470H		368 x 189 x 40	425 562 28 (Iveco) 150 5201 (Scania)
11.3730.210H		367 x 187 x 60	84434473 (CNH) ♦ 425 459 90 425 562 27 (Iveco) 150 5202 (Scania)
20.2710.620		124 x 59 x 18 / 500	50.00.021.163 (Irisbus)
20.2710.630H		124 x 59 x 18 / 2500	50.06.232.484 (Irisbus)
59.2710.402H		701 x 641 x 200	284232 (Concorde)
51.3732.326H		384 x 205 x 116	180 5203 (Scania) 50.06.232.482 (Irisbus)
15.3731.470H		368 x 189 x 40	425 562 28 (Iveco) 150 5201 (Scania)
11.3730.210H		367 x 187 x 60	84434473 (CNH) ♦ 425 459 90 425 562 27 (Iveco) 150 5202 (Scania)
20.2480.217H		108 x 50 x 15 / 5000	425 459 85 (Iveco)
59.2710.406		701 x 746 x 200	AA-01977 (Plaxton)
51.3732.326H		384 x 205 x 116	180 5203 (Scania) 50.06.232.482 (Irisbus)
15.3731.470H		368 x 189 x 40	425 562 28 (Iveco) 150 5201 (Scania)
11.3730.210H		367 x 187 x 60	84434473 (CNH) ♦ 425 459 90 425 562 27 (Iveco) 150 5202 (Scania)
20.2480.216H		108 x 50 x 15 / 2000	145 1226 (Scania)
59.2710.412		701 x 801 x 200	4254 5983 (Iveco)
51.3732.326H		384 x 205 x 116	180 5203 (Scania) 50.06.232.482 (Irisbus)
15.3731.470H		368 x 189 x 40	425 562 28 (Iveco) 150 5201 (Scania)
11.3730.210H		367 x 187 x 60	84434473 (CNH) ♦ 425 459 90 425 562 27 (Iveco) 150 5202 (Scania)
20.2710.620		124 x 59 x 18 / 500	50.00.021.163 (Irisbus)
20.2710.630H		124 x 59 x 18 / 2500	50.06.232.484 (Irisbus)
20.2710.111H		a 183 x 145 x 107	MIR-00239 (Wrightbus) 09-37986101-8 (Marcopolo)
20.2710.121		a 183 x 145 x 107	MIR-00240 (Wrightbus) 09-37986101-8 (Marcopolo)
20.2710.200H		b 183 x 181 x 84	AA-01978 (Plaxton) MIR-00243 (Wrightbus)

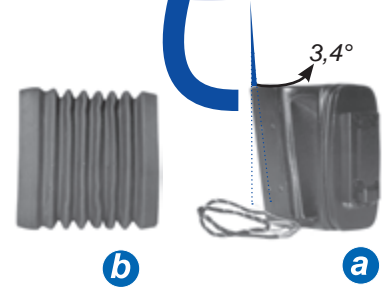

UNIVERSAL

UNIVERSAL

300-1				Ø 30-35 mm
	Beschreibung description descripțion descripção descripcione description benamning popis описаније описаник			
55.3000.117H		315 x 30 ø	7033 1061 (Volvo) N1.01103-5730 (Neoplan) 000 810 31 17 (Mercedes) 010 2088 (Scania)	
40.3005.222		300 x 3 ø		
11.3001.100		240 x 50 x 16	000 810 16 13 (Mercedes) 010 8832 (Scania)	



202				INTEGR.
	Beschreibung description descripțion descripção descripcione description benamning popis описаније описаник			
1 55.2020.177H		229 x 98 x 30	217 611 (Fritzmeier) 38 346 (Hymer) 264 73 41 (Faun)	
2 55.2021.177		229 x 98 x 30	3844 (Fritzmeier)	

246 P				INTEGR.
	Beschreibung description descripțion descripção descripcione description benamning popis описаније описаник			
55.2461.113		420 x 220 x 35	81.63730-6189 (MAN)	
40.2460.214H		410 x 210 x 3	000 811 67 33 (Mercedes) 81.63733-0015 (MAN) 264 71 17 (Faun)	



UNIVERSAL

Heizfolien
heating foils
feuilles chauffantes
mantas aquecedoras
resistenze
láminas de calefacción
element
vyhřívací fólie
нагревательные элементы
ısıtıcı folyolar

ohne Stecker
without connector
sans fiche
samente cabo
solo cavo
sin enchufe
utan stift
bez konektoru
без штекера
konektörsüz

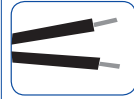

Rundstift
round pin
fiche coaxiale
connector circ. macho
connettore tondo
pin redondo
rundstift
kruhový pin
круглый штифт
yuvarlak pin

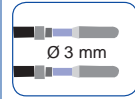

Stoßverbinder
fish joint
joint droit
conectores anzol
connettore piatto
pin articulable
isolerade stift
nástrčný konektor
контактный штекер
bağbaşa bağlantı

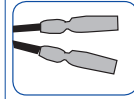

4 Flachstecker
4 flat connectors
4 coses Faston
4 conectores planos
4 connettore faston
4 conectores planos
4 flatstift
4 plochý konektor
4 плоских штекера
4 adet düz konektör

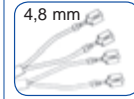

Rundbuchse
combination socket
ronde prise femelle
connector circ. fema
connet. tondo (fem.)
bujie redondo
rundstift
kruhový konektor
круглое гнездо
birleşik socket

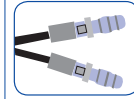

2 Flachstecker
2 flat connectors
2 coses Faston
2 conectores planos
2 connettore faston
4 conectores planos
2 flatstift
2 plochý konektor
2 плоских штекера
2 adet düz konektör

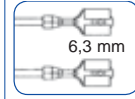

Gruppe category groupe categoria categoria kategorij skupina категория kategorij	I	12 V	10.6111.100	-	-	10.6111.140	10.6111.150	-
		24 V	10.6121.100	10.6121.110		10.6121.140	10.6121.150H	10.6121.160
II	12 V	10.6211.100	-	-	10.6211.140	10.6211.150	-	
	24 V	10.6221.100	-	10.6221.120	10.6221.140	10.6221.150	10.6221.160	
III	12 V	10.6311.100	-	-	-	-	-	
	24 V	10.6321.100	-	10.6321.120	-	-	10.6321.160	
IV	12 V	-	-	-	-	10.6411.150	-	
	24 V	10.6421.100	-	10.6421.120	10.6421.140	10.6421.150	-	

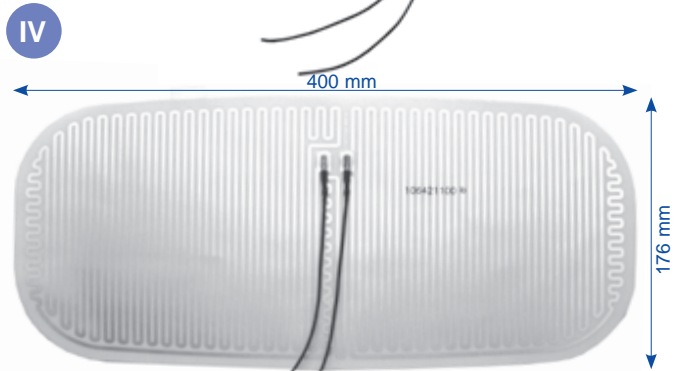
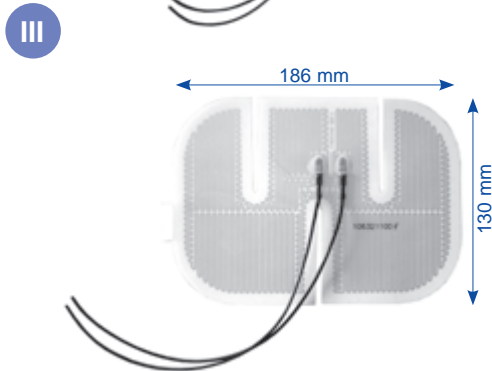

MEKRA

Beschreibung
description
description
descripção
description
benámenning
Popis
özellik

mm

OE

08.2415.250

31 x 16

008 820 65 10 (Mercedes)



Thermoschalter • thermo switch • commutateur thermostatique • termostato
termostato • termostato • termostatbrytare • termosplnač • термостат • termostat

UNIVERSAL

Aufsteckkeile • Mounting wedges • semelles de fixation • cunhas desmontáveis • cunhas desmontables • monteringsklar • nástrčné klíny • установочные клинья • bağlanti parçaları

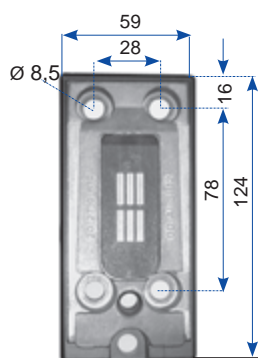
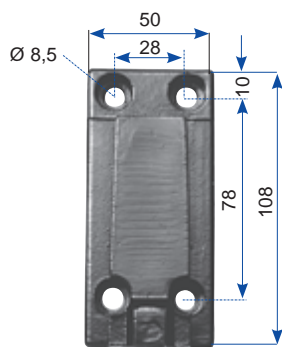

248-2

MEKRA		mm		OE	
Beschreibung description description description description Benaming popis описание özellik					
20.2480.210H		108 x 50 x 15	7035 2646 (Volvo) ♦ 671 811 0111 (Mercedes) 218 142 (Fritzmeier) ♦ 144 8217 (Scania)		
20.2480.211		108 x 50 x 15 / 2500	145 1227 (Scania) ♦ 2085 4088 (Volvo)		
20.2480.216H		108 x 50 x 15 / 2000	145 1226 (Scania)		
20.2480.217H		108 x 50 x 15 / 5000	425 459 85 (Iveco)		
20.2480.223		108 x 50 x 15 / 150	81.63731-6478 (MAN) ♦ 2051 5454 (Volvo)		

271 A

MEKRA		mm		OE	
Beschreibung description description description description Benaming popis описание özellik					
20.2710.620		124 x 59 x 18 / 500	50.00.021.163 (Irisbus)		
20.2710.630H		124 x 59 x 18 / 2500	50.06.232.484 (Irisbus)		

Heizkabel mit Steckanschluss • Heating cable with plug • câble chauffant avec prise • cavo de aquecimento com plug • cavo con presa • cable de calefacción con clavija de enchufe • kabel för uppvärmning med anslutningskontakt • vyhřívací kabel se zástrčkou • кабель нагревателя с штекерным разъемом • fişli ısıtıcı kablolu



MEKRA		mm		OE	
Beschreibung description description description description Benaming popis описание özellik					
09.2070.101H		2070	161 0077 0009 (MAN Steyr) ♦ 81.25432-0149 (MAN) 000 150 55 33 (Mercedes)		
09.2000.301H		2000	8.688.000.305.0 (Setra) ♦ 83.25402-6010 (MAN) 1620 025 (DAF)		

Steuerkabel • control cable • câble de commande • cabo de controle • cavo di controllo • cable de control • kabel för elstyrning • ovládací kabel • кабель управления • kontrol kablolu



MEKRA		mm		OE	
Beschreibung description description description description Benaming popis описание özellik					
09.3200.310H		2000	174 2422 (Scania) ♦ 81.25404-6247 (MAN) 8.919.964.241.4 (Setra)		
09.3200.320H		2000	000 159 02 68 (Mercedes) ♦ 684 406 (Fritzmeier)		
09.3300.421		2000	684 405 (Fritzmeier)		

Versorgungsleitung • supply cable • câble d'alimentation • cabo de alimentação • cavo di alimentazione • cable distribuidor • elkabel • zdrojový kabel • провод питания • besleme kablolu



MEKRA		mm		OE	
Beschreibung description description description description Benaming popis описание özellik					
09.3200.210		1000			
09.3200.220		1000			

UNIVERSAL

Komplette Kabelsätze für elektrisch verstellbare Spiegel • Cable sets for remote controlled mirrors • kit complet pour réglage électrique • kit de cabos para espejos eléctricos • set di cavi per specchi elettrici • juego completo de cables para espejos ajustables por mando eléctrico • kabelsats för eljusterbara speglar • kompletní kabelová sada pro elektricky ovládaná zrcadla • полный комплект кабелей для электроуправляемых зеркал • uzaktan kumandal aynalar için kablo setleri

MEKRA		Beschreibung description descripção descrizione descripção benämning popis описание özellik		mm	OE
08.3200.250H	1 12V 24V	1	59 x 26 ø	F 198.810.150.010 (Agco)	
08.3200.233H	2 12V 24V	2	42 x 42 x 54	175 9703 (Scania) ✦ 161 0077 0704 (MAN Steyr) 003 545 10 07 (Mercedes) ✦ 81.25505-6140 81.25525-0232 (MAN) ✦ 99707000161 684 272 (Fritzmeier) ✦ 7031 0152 (Volvo) 131170 (Claas)	



MEKRA		Beschreibung description descripção descrizione descripção benämning popis описание özellik		mm	OE
09.3200.410H	1	2000	50.00.244.768 (Renault) ✦ 161.00.77.0015 (MAN Steyr) 383 002 (Hymer)		
08.3200.250H	12V 24V	59 x 26 ø	F 198.810.150.010 (Agco)		
09.3200.210	2,8 1	1000			
09.3200.310H	1	2000	174 2422 (Scania) ✦ 81.25404-6247 (MAN) 8.919.964.241.4 (Setra)		



MEKRA		Beschreibung description descripção descrizione descripção benämning popis описание özellik		mm	OE
09.3200.420H	2 Typ 282 Typ 320 Typ 363 *	2000	9 981 630 (Hymer)		
08.3200.233H	2 12V 24V	42 x 42 x 54	175 9703 (Scania) ✦ 161 0077 0704 (MAN Steyr) 003 545 10 07 (Mercedes) ✦ 81.25505-6140 81.25525-0232 (MAN) ✦ 99707000161 684 272 (Fritzmeier) ✦ 7031 0152 (Volvo) 131170 (Claas)		
09.3200.220	6,3 2	1000			
09.3200.320H	2 Typ 320 Typ 330 Typ 340 Typ 368 Typ 373 Typ 385	2000	000 159 02 68 (Mercedes) ✦ 684 406 (Fritzmeier)		
09.3400.420	2	2000	1905 564 00 (Neoplan) ✦ 161.00.77.2027 (MAN Steyr)		
08.3200.233H	12V 24V	42 x 42 x 54	175 9703 (Scania) ✦ 161 0077 0704 (MAN Steyr) 003 545 10 07 (Mercedes) ✦ 81.25505-6140 81.25525-0232 (MAN) ✦ 99707000161 684 272 (Fritzmeier) ✦ 7031 0152 (Volvo) 131170 (Claas)		
09.3200.220	6,3	1000			
09.3200.320H	1	2000	000 159 02 68 (Mercedes) ✦ 684 406 (Fritzmeier)		
09.3300.421	1	2000	684 405 (Fritzmeier)		



* Typ / type / tipo / тип / tip 0.368
Kabelsatz nur für Artikel 51.3680.187
cable set only for item 51.3680.187
le nécessaire de cable ne concerne que 51.3680.187
conjunto de cabos somente para item 51.3680.187
set di cavi solo per l'articolo 51.3680.187
set solo para referencia 51.3680.187
kabelsats endast för art.nr 51.3680.187
kabelová sada jen pro zrcadlo 51.3680.187
комплект кабеля только для продукта 51.3680.187
sadece 51.3680.187 için kablo seti

** 2 Stück im Lieferumfang des kompletten Kabelsatzes 09.3200.420
We supply 2 pieces in the complete cable set 09.3200.420
Le kit de câbles 09.3200.420 est composé de deux unités de 09.3200.320
Fornecemos 2 peças no kit de cabos completo 09.3200.420
Il kit di cavi 09.3200.420 è composto di due pezzi.
Se suministran dos unidades en el kit completo de cable 09.3200.420
komplett kabelsats 09.3200.420 inkluderar 2 st. 09.3200.320
2 kusy obsahuje kompletní kabelová sada 09.3200.420
2 штуки входят в объём поставки набора кабеля 09.3200.420
komple kablo setinde (09.3200.420) 2 adet 09.3200.320 bulunmaktadır

UNIVERSAL

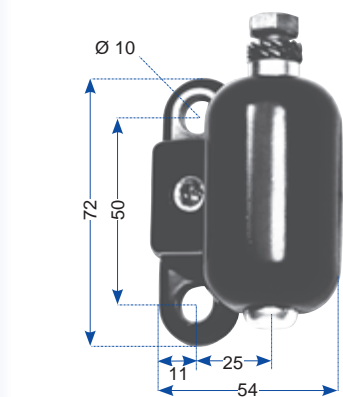
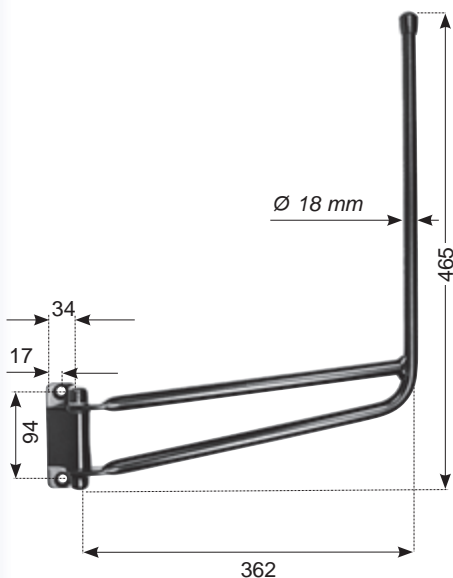

IVECO-Magirus

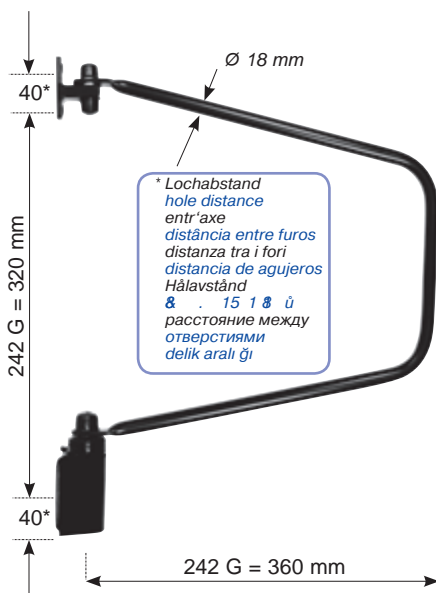

UNIVERSAL

252 A



Ø 18 mm

MEKRA

Beschreibung
description
descripción
descripção
descripción
Benamning
popis
описание
özellik



OE

58.2520.011H



350 x 465 x 18 ø

58.2520.012H



350 x 465 x 18 ø

- Winkelstellung stufenlos verstellbar (Friktion), Anschraubteile aus Alu-Druckguß
- angular position infinitely adjustable (friction), screw-on parts out of die cast aluminium
- réglage angle par friction sans intervalles, éléments de fixation en aluminium moulé
- Posição do ângulo ajustável sem graduação, elementos de fixação de alumínio fundidos sob pressão
- posizione regolabile (con frizione), parti filettate esterne alla pressofusione in alluminio

- posición del ángulo ajustable sin graduación, elementos de fijación de aluminio fundido a presión
- vinkel steglöst justerbar, monteringsdetalj av alu-gjutgods
- . 7. 5 8 *7
17 18 & . * -18 *1 . -18 *1 1& -7
- безступенчатая настройка угла наклона (фрикция)
- 15 . 1 5 1 5 . & ğ) . . 8 & . /
. . . / 7 /

260/1



MEKRA

Beschreibung
description
descripción
descripção
descripción
Benamning
popis
описание
özellik



OE

20.2600.111H



36 x 54 x 72

81.63731-0157 (MAN) * 220 999
(Fritzmeier)
269 56 77 (Faun)

20.2600.112H



36 x 54 x 72

81.63731-0158 (MAN) * 220 998
(Fritzmeier)
269 56 78 (Faun)

- Die Spiegelstange wird zwischen 2 extra starke Zahnscheiben mit einer Schraube M8 geklemmt und kann so beliebig eingestellt werden. Nach der Klemmung kann die Spiegelstange abgeklappt werden u. rastet wieder in die ursprüngliche Lage ein.
- The mirror holder is clamped between two extra strong grips with an M 8 screw and can thus be adjusted as required. After clamping the mirror arm can be swung out and then locks at the initial position.
- Le bras support est fixé entre deux rondelles dentées renforcées par une vis M 8 et réglage selon besoin. Après le serrage on peut totalement replier le bras de fixation qui crante dans sa position initiale.
- O suporte do espelho é preso entre dois grampos fortes, com um parafuso M8 e pode ser ajustado quando necessário. Depois de preso, o braço do espelho pode ser movido para fora e trava então na posição inicial.
- Il braccio è bloccato tra due arresti rinforzati con vite M 8 può essere posizionato in più modi. Dopo il fissaggio, il braccio può essere regolato e dopo il fissaggio, riportato nelle posizione originale.

- Se aprieta el brazo de espejo entre dos arandelas dentadas extrafuertes mediante un tornillo M 8. De esta manera se puede ajustarlo individualmente. Después del aprieto se puede plegar el brazo de espejo que vuelve encajarse en su posición inicial.
- Armen fästs mellan 2 extra starka klammer med M8 skruvar och kan då justeras efter eget önskemål. Efter montering kan spegelarmen justeras och låses tillbaka till ursprunglig position.
- 17 - . 5 8* 17 / / 5.
1 & 1 - / ú . 18 . é 5 8
15 8* 5 / ú & - 5 . 1 1 é 8 & 1
ú 8 & 1 . 1 *
- Брус зеркала зажимается между двумя особо толстыми шестерными пластинками с помощью винта М8 и может, таким образом, настраиваться по-любому.
- ayna tutucusu M 8 vidası ile ekstra kuvvetli bir şekilde sıkıştırılmıştır ve istendiği gibi ayarlanabilmektedir. Ayna kolu dışarı doğru döndürülebilir ve sonra ilk pozisyonuna geri döner.

242 A



Ø 18 mm

MEKRA

Beschreibung
description
descripción
descripção
descripción
Benamning
popis
описание
özellik



OE

58.2423.320H



400 x 360 x 18 ø

- Anschraubteile aus Stahlblech und Alu-Druckguß - federrastend
- Screw-on parts made out of sheet steel and die cast aluminium - with spring catch
- éléments de fixation en tôle d'acier et en aluminium moulé - crantage à ressorts
- suportes de fixação feitos em aço estampado e alumínio injetado sob pressão - com molas de retenção
- parti filettate esterne alla pressofusione in alluminio con moschettoni

- elementos de fijación de chapa de acero y de aluminio fundido a presión - enclavándose mediante muelle
- monteringsdetalj av plåt och gjutgods - med fjäderstopp
- 17 18 & . * -18 *1 . -18 *1 1& -7
. 7 7 18
- Навинчивающиеся детали из листовой стали и алюминиевой отливки
- vidalama parçaları sac çeliği ve alüminyum.



UNIVERSAL

255 A				Ø 20 mm
--------------	--	--	---	---------

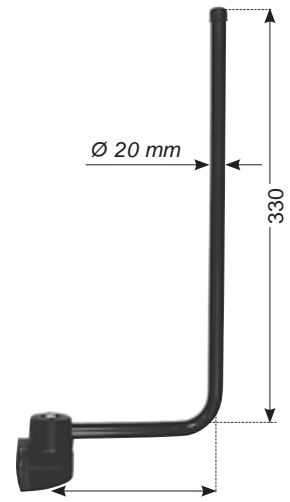
	Beschreibung description descripción descrizione descripción بەرنامینگ описание özellik		
58.2550.110	 90°  	330 x 120 x 20	







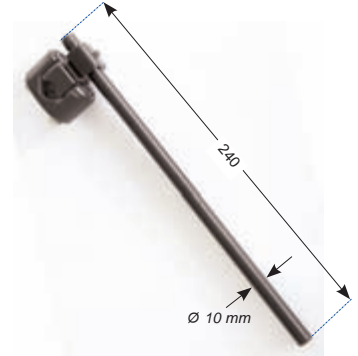



156/3 A				Ø 10 ⇨ 14-20 mm
----------------	--	--	---	-----------------

	Beschreibung description descripción descrizione descripción بەرنامینگ описание özellik		
11.1523.010	  	250 x 10	AZ100261 (John Deere)



260 A				Ø 18 ⇨ 18-20 mm
--------------	--	--	--	-----------------

	Beschreibung description descripción descrizione descripción بەرنامینگ описание özellik		
58.2600.010H	  	160 x 18	
58.2601.010	  	240 x 18	1905 520 00 (Neoplan)

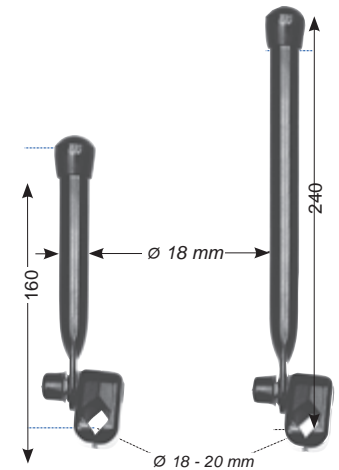

300 A				Ø 16 ⇨ 30-35 mm
--------------	--	--	---	-----------------

	Beschreibung description descripción descrizione descripción بەرنامینگ описание özellik		
11.3001.100	  	240 x 50 x 16	000 810 16 13 (Mercedes) ♦ 010 8832 (Scania)

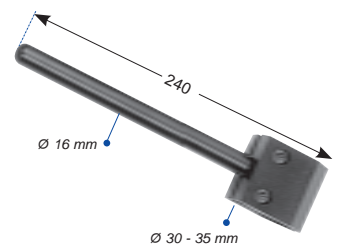

152 A				Ø 14 / 16 mm
--------------	--	--	---	--------------

	Beschreibung description descripción descrizione descripción بەرنامینگ описание özellik		
11.1523.212	  	120 x 31 x 14	423 459 81 (Iveco) ♦ 7031 0110 (Volvo)

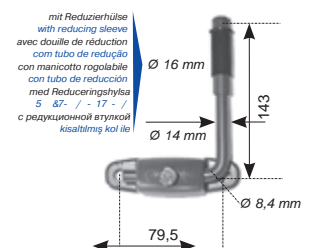

UNIVERSAL

UNIVERSAL

248 A



Ø 18 mm

MEKRA

Beschreibung
description
descripción
description
benamning
описаније
описаније



OE

58.2481.011H		58°	292 x 100 x 18 ø	
58.2481.012		122°	292 x 100 x 18 ø	
58.2484.612		103°	210 x 240 x 18 ø	357 810 67 14 (Mercedes)
58.2485.011H		150°	277 x 533 x 18 ø	
58.2485.012H		30°	277 x 533 x 18 ø	

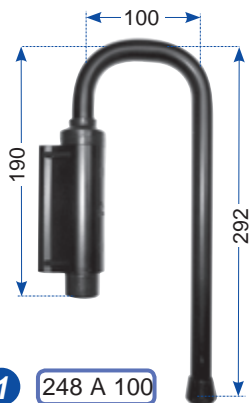

1 248 A 100

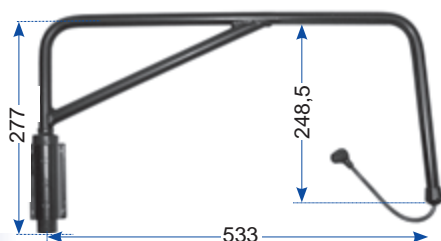

2 248 A 533

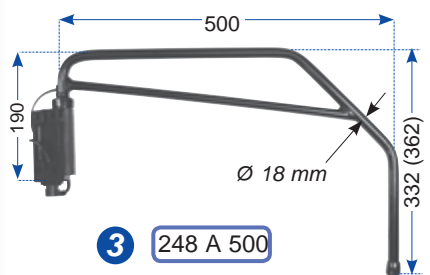

3 248 A 500

- Typen 248 A / 270:
Abnehmbare Spiegelhalter, federrastend
Raststellung indiv. einstellbar (Grundeinstellung 7 Tabelle)
Aufsteckteil: bei unbeheizten Stangen separat bestellen
- types 248 A / 270:
Removable steel tube mirror holders, with spring catch
Stop location individually adjustable (standard 7 column)
Mounting wedge / unheated holders: pls. order separately
- types 248 A / 270:
bras support tubulaire, amovible, crantage à ressorts
position de crantage adaptable individuellement
(standard 7 tableau)
Les semelles de fixation pour rétroviseurs non chauffants sont à commander séparément
- Tipos 248 A / 270:
Suportes tubular de aço removíveis, com mola de retenção. Posição de batente ajustável individualmente (padrão 7 coluna). Cunha de montagem e suportes não aquecidos: favor pedir separadamente.
- tipos 248 A / 270:
braccio, con moschettone; angolazione regolabile individualmente (posizione standard 7 tabella)
Supporto a cuneo per braccio non riscaldato deve essere ordinato separatamente.
- tipos 248 A / 270:
soporte desmontable, enclavándose mediante muelle
posición de enclavamiento individualmente ajustable (posición básica vea datos que aparecen en la vista)
Para barras no calentadas se tiene que pedir adicionalmente la cuña de fijación.
- typer 248 A / 270:
demonterbar hållare, fjäderstop;
stop individuellt justerbart (standardinställning 7 kolumn)
Kil för hållare utan värme beställs separat.
- typ 248 A / 270:
odnímatelný & - & 5 7 1817
& 8 & 7 . ě 5 8 . - . & 5 8 , 78 & 1
8 7. ě 5 ě - . 5 7 8* ř8 * & -ů / 75
1 , & 5 / 15 ě
- тип 248 A / 270:
снимающийся держатель зеркала с фиксируемой пружиной, позиция раstra устанавливается индивидуально (основная настройка - см. таблицу)
насадочный клин при не обогреваемых брусках заказывается отдельно
- Çıkarılabilir çelik boru ayna kolu, yaylı kilit mekanizmalı, ayarlanabilir (Standard sütuna bakınız). Bağlantı parçası / ısıtıcısız kol (lütfen ayrıca sipariş ediniz)

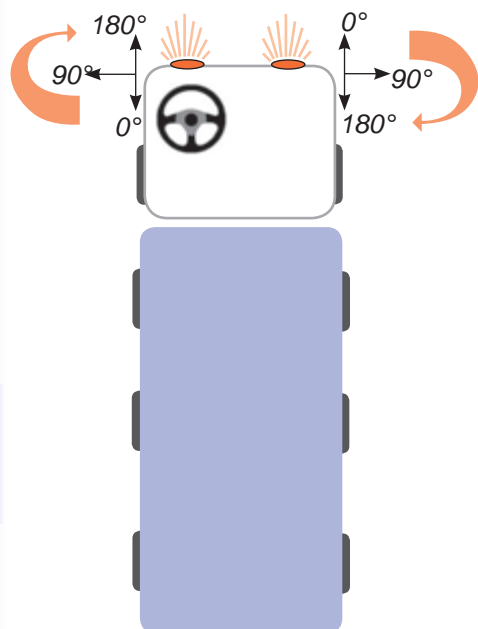

Definition: Winkelstellung der Spiegelstangen
definition: degree of angle of the mirror brackets
définition: angle de positionnement du bras de rétroviseur
definição: ângulos de montagem para braços de fixação
definizione: orientamento del braccio
definición: ángulo de soporte hacia vehículo
definition: Inställningen av vinkel på spegelarm
(* 18 5 8 & -ů ě * & .
Определение: угловая позиция брусков зеркала
açıklama : ayna kollarının açıları

UNIVERSAL

270 A



Ø 28 mm

MEKRA

Beschreibung
 description
 descripción
 descrizione
 descripción
 benjaminning
 ppplis
 omlkacivne
 ozealik



OE

1	58.2704.051H		90°	270 x 464 x 28 ø	
2	58.2704.048		90°	216 x 514 x 28 ø	HEO 627 810 M1 47 (EvoBus) * 1905 508 000 (Solaris)
	58.2704.044		90°	216 x 514 x 28 ø	7033 1060 (Volvo)
	58.2704.088		120°	216 x 514 x 28 ø	50.06.232.165 (Irisbus)
3	58.2704.070H		6°	732 x 327 x 28 ø	
	58.2704.086H		6°	732 x 327 x 28 ø	
	58.2704.093H		6°	732 x 327 x 28 ø	
4	58.2705.009		17°	668 x 350 x 28 ø	2050 5864 (Volvo)
	58.2705.007P *		17°	668 x 350 x 28 ø	2050 5863 (Volvo)
	58.2705.008		17°	668 x 350 x 28 ø	2050 5851 (Volvo)
	58.2705.003 *		17°	668 x 350 x 28 ø	7035 2000 (Volvo)
	58.2705.002		17°	668 x 350 x 28 ø	7030 9621 (Volvo)
	58.2705.001 *		17°	668 x 350 x 28 ø	7030 9620 (Volvo)
	61.2708.842H				150 5203 (Scania)

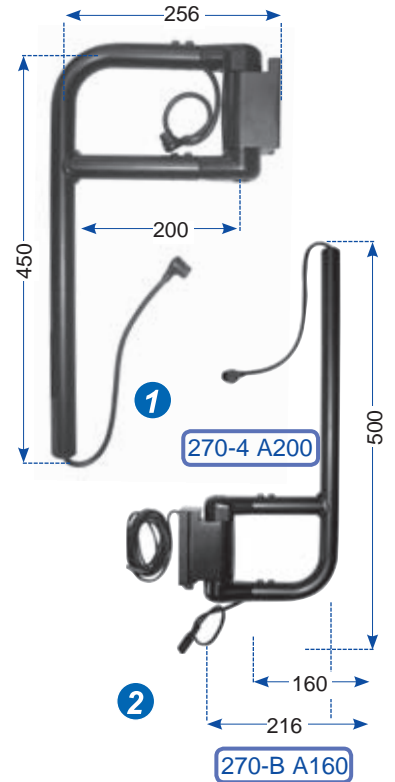

* mit zusätzlicher Strebe zur Montage eines Weitwinkelspiegels
 with additional support for the mounting of a wide angle mirror
 avec bras additionnel pour montage d'un rétroviseur grand angle
 com suporte adicional para a montagem para um espelho auxiliar
 con ulteriore supporto per il montaggio di uno specchio grand'angolo
 con soporte adicional para un espejo de gran ángulo
 Förberedd för montering av vidvinkelspegel
 s přidavnou vzpě 17 1 / 1 1-1 * *1 &
 с дополнительной распоркой для монтажа широкоугольного зеркала
 geniş görüş aynasının montajı için ek destekli

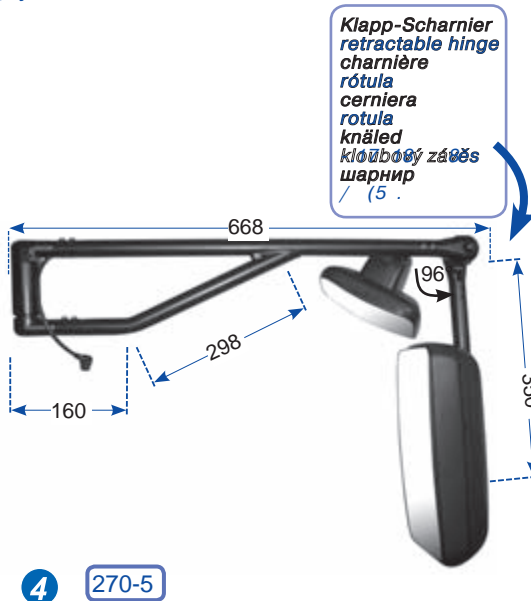
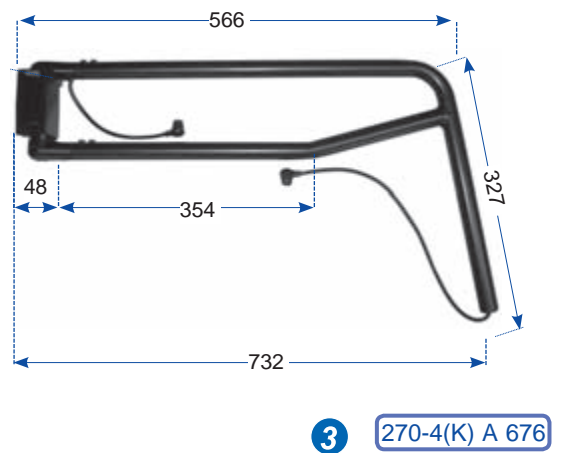

Klapp-Scharnier
 retractable hinge
 charnière
 rótula
 cerniera
 rotula
 knäled
 kloubový zářez
 шарнир
 / (5 .

Klappstange • hinged tube • bras rabattable • braço de fixação com rotula
 escamoteável • braccio flessibile (con cerniera) • soporte multidireccional
 hängande spegel-arm med knäled • 5-.1 & -
 складывающийся кронштейн • / (5 ..1 -1.

ALLGEMEINE GESCHÄFTSBEDINGUNGEN (AGB)

Allgemeine Bedingungen

Den Vertragsbeziehungen zwischen uns, Mekra Lang GmbH & Co. KG, und unseren Kunden liegen ausschließlich die nachfolgenden AGB zugrunde. Unsere Angebote richten sich ausschließlich an Unternehmer i.S.v. § 14 BGB. Abweichende Geschäftsbedingungen des Kunden werden, selbst bei Kenntnis, nicht Vertragsbestandteil. Unsere Angebote sind stets freibleibend. Unsere AGB gelten mit der Auftragserteilung, spätestens mit der Annahme der Ware als anerkannt. Diese AGB gelten bei ständigen Geschäftsbeziehungen auch für alle künftigen Geschäfte. Sollten einzelne Bestimmungen ganz oder teilweise unwirksam sein oder werden, so wird hierdurch die Gültigkeit der übrigen Bestimmungen nicht berührt. Die ganz oder teilweise unwirksame Regelung soll durch eine Regelung ersetzt werden, deren wirtschaftlicher Erfolg dem der unwirksamen möglichst nahe kommt.

Vertragsschluß und Preise

Mit der Bestellung einer Ware erklärt der Kunde verbindlich, die bestellte Ware erwerben zu wollen. Er ist an diese Erklärung zwei Wochen gebunden. Wir sind berechtigt, das in der Bestellung liegende Vertragsangebot innerhalb von zwei Wochen nach Eingang bei uns anzunehmen. Die Annahme kann schriftlich, elektronisch oder durch Auslieferung der Ware an den Kunden erklärt werden. Die Verpflichtungen im elektronischen Geschäftsverkehr gem. § 312e Abs. 1 Satz 1 Nr. 1 bis 3 und Satz 2 BGB werden ausgeschlossen.

Der Vertragsschluß erfolgt unter dem Vorbehalt der richtigen und rechtzeitigen Selbstbelieferung durch unsere Zulieferer. Dies gilt nur für den Fall, dass die Nichtbelieferung nicht von uns zu vertreten ist, insbesondere bei Abschluss eines kongruenten Deckungsgeschäftes mit unseren Zulieferern. Der Kunde wird über die Nichtverfügbarkeit der Leistung unverzüglich informiert und die Gegenleistung, soweit bereits geleistet, unverzüglich zurückerstattet.

Alle vertraglichen Zahlungsverpflichtungen sind ausschließlich in EURO zu erfüllen. Die Preise verstehen sich netto ab Werk bzw. Auslieferungslager. Fracht-, Verpackungs-, Einfuhrkosten, Zoll und sonstige Nebenabgaben gehen zu Lasten des Käufers. Im Inland erfolgen Lieferungen ab einem Warennettowert von EUR 600,- fracht- und verpackungsfrei.

Lieferzeit und Lieferverpflichtung

Für Umfang, Art und Zeitpunkt der Lieferung ist unsere schriftliche oder elektronische Auftragsbestätigung maßgebend. Teil-Lieferungen sind zulässig.

Eine Verpflichtung zur Einhaltung als verbindlich bezeichneter Lieferfristen wird nur unter der Voraussetzung eines ungestörten Betriebs- und Vertriebsablaufs übernommen; insbesondere in Fällen höherer Gewalt und sonstiger störender Ereignisse bei uns, bei unseren Lieferanten oder bei den Transportunternehmen, beispielsweise Betriebs- oder Verkehrsstörungen, Feuer, Überschwemmungen, Arbeitskräfte-, Energie- oder Verkehrsmangel, Streik, Aussperrung, behördliche Maßnahmen sowie technische oder technologische Umstände, welche die Auftragsausführung wesentlich erschweren, entbinden uns von der Pflicht zur rechtzeitigen Lieferung oder geben uns das Recht, unsere Lieferung ohne Nachlieferpflicht einzustellen. Sofern nichts Abweichendes vereinbart ist, sind wir berechtigt, bereits vor einem genannten Liefertermin zu leisten. Ebenso gilt, sofern nichts Abweichendes vereinbart ist, eine bis maximal zwei Wochen über einem genannten Liefertermin liegende Leistung unsererseits nicht als verspätet.

Lieferfristen gelten als eingehalten, wenn bis zu ihrem Ablauf die Ware das Werk oder Auslieferungslager verlassen hat oder dem Besteller die Anzeige unserer Versandbereitschaft zugegangen ist. Nachträgliche Änderungen des Vertrages verlängern die Lieferfristen angemessen.

Bei Verträgen, deren Erfüllung aus mehreren Lieferungen besteht, ist Nichterfüllung, oder mangelhafte oder verspätete Erfüllung einer Lieferung ohne Einfluss auf andere Lieferungen aus dem Vertrag.

Zahlungsverzug, der Antrag auf Eröffnung des Insolvenzverfahrens, die Abgabe einer eidesstattlichen Offenbarungsversicherung gemäß § 807 ZPO, eintretende Zahlungsschwierigkeiten oder das Bekanntwerden einer wesentlichen Verschlechterung der Vermögensverhältnisse des Bestellers berechtigen uns, Lieferungen sofort einzustellen und die Erfüllung laufender Verträge zu verweigern. Gleichzeitig sind wir berechtigt, noch nicht fällige Forderungen gegen den Besteller sofort fällig zu stellen.

Versand, Gefahrenübergang

Verpackung, Versandweg und Transportmittel sind im Falle des Fehlens besonderer Vereinbarungen unserer Wahl überlassen.

Die Gefahr des zufälligen Untergangs und der zufälligen Verschlechterung der Ware geht mit der Übergabe, beim Versendungskauf mit der Auslieferung der Sache an den Spediteur, den Frachtführer oder der sonst zur Ausführung der Versendung bestimmten Person oder Anstalt, auf den Käufer über. Der Übergabe steht es gleich, wenn der Käufer im Verzug der Annahme ist.

Ware aus Abrufaufträgen ist, wenn nicht anders vereinbart, innerhalb von 3 Monaten nach Erteilung der Auftragsbestätigung abzunehmen.

Versicherung gegen Bruch- und Transportrisiken werden nur auf besonderen Wunsch gegen Berechnung der Kosten übernommen.

Zoll und sonstige Spesen, gehen zu Lasten der Käufer. Die Unkosten für Bezahlung der zur Einfuhr in das Bestimmungsland notwendigen Papiere, gehen zu Lasten des Käufers.

Zahlung, Zahlungsbedingungen

Rechnungen sind zahlbar:

- innerhalb von 14 Tagen ab Rechnungsdatum mit 2 % Skonto vom Rechnungsendwert.
 - innerhalb von 30 Tagen ab Rechnungsdatum ohne Skonto vom Rechnungsendwert.
- Kassa - Skonto wird nur gewährt, wenn sämtliche Zahlungsverpflichtungen aus früheren Lieferungen erfüllt sind und der Rechnungsbetrag pünktlich bis zu den vorgenannten Fälligkeitstagen bei uns in bar vorliegt oder unserem Konto gutgeschrieben ist. Wechselhereingabe kann also nicht zur Gewährung von Kassa - Skonto führen. Bei barloser Zahlung, insbesondere auch bei Scheckhereingabe, kommt es auf den Zeitpunkt der Gutschrift an.

Bei Zahlung oder Gutschrift unter Vorbehalt, unter einer Bedingung oder sonstigen Einschränkungen kann Skonto nicht gewährt werden. Das Risiko des Zahlungsweges trägt der Besteller. Rechnungen für Werkzeuge sind ohne Skontoabzug sofort zahlbar.

Die Annahme von Wechseln und Schecks erfolgt nur erfüllungshalber. Entsprechende Gutschriften erfolgen nur unter Vorbehalt des Einganges des vollen Betrages. Die Hereinnahme von fremden oder eigenen Akzepten behalten wir uns vor. Kosten und Diskontospesen gehen zu Lasten des Bestellers. Eine Gewähr für Vorlage und Protest übernehmen wir nicht. Protesterhebung eigener Wechsel des Bestellers oder nicht sofortige Abdeckung protestierter Fremdwechsel ermächtigen uns, sämtliche noch laufende Wechsel zurückzugeben. Gleichzeitig sind wir berechtigt, nicht fällige Forderungen gegen den Besteller sofort fällig zu stellen. Vordatierte Schecks werden nicht angenommen.

Bei Überschreitung des Zahlungstermins werden Verzugszinsen in Höhe von 8 % über dem jeweiligen Basiszinssatz gem. § 247 BGB fällig. Die Geltendmachung eines weiteren Verzugschadens oder anderer Rechte bleibt vorbehalten.

Voraus- und Abschlagszahlungen werden nicht verzinst. Zur Aufrechnung oder Einbehaltung von Zahlungen ist der Besteller nur berechtigt, wenn seine Gegenforderung unbestritten oder rechtskräftig festgestellt ist. Der Kunde kann ein Zurückbehaltungsrecht nur ausüben, wenn sein Gegenanspruch auf demselben Vertragsverhältnis beruht.

Beim Ausgleich von Rechnungen sind vom Kunden seine Kundennummer und die Rechnungsnummer anzugeben. Verzögerungen oder Fehlbuchungen, die infolge Nichteinhaltung dieser Verpflichtungen eintreten, gehen zu Lasten des Kunden.

Eigentumsvorbehalt, Factoring

Die gelieferte Ware bleibt bis zur Bezahlung aller bestehenden Forderungen aus der Geschäftsverbindung mit dem Kunden unser Eigentum. Der Besteller ist im Rahmen des ordnungsgemäßen Geschäftsganges zur Weiterveräußerung der Vorbehaltsware berechtigt; eine Verpfändung oder Sicherungsübereignung ist ihm jedoch nicht gestattet. Bei einem Weiterverkauf von Vorbehaltsware auf Kredit ist er verpflichtet, unsere Rechte zu sichern.

Die Forderungen des Bestellers aus der Weiterveräußerung der Vorbehaltsware tritt dieser schon jetzt in Höhe des Rechnungsbetrages an uns ab; Wir nehmen diese Abtretung an. Ungeachtet der Abtretung ist der Besteller zur Einziehung solange berechtigt, als er seinen Verpflichtungen uns gegenüber aus dem zugrundeliegenden Vertragsverhältnis nachkommt und nicht in Vermögensverfall gerät. Andernfalls hat er auf unser Verlangen die zur Einziehung erforderlichen Angaben über die abgetretene Forderung zu machen und seinen Schuldner diese Abtretung anzuzeigen. Für diesen Fall behalten wir uns vor, die Forderung selbst einzuziehen.

Eine etwaige Be- oder Verarbeitung der Vorbehaltsware durch den Unternehmer erfolgt stets im Namen und im Auftrag für uns, ohne dass uns jedoch Verbindlichkeiten hieraus erwachsen dürfen. Bei der Verarbeitung der Vorbehaltsware mit anderen, uns nicht gehörenden Waren, steht uns der dabei entstandene Miteigentumsanteil an der neuen Sache im Verhältnis des Wertes der Vorbehaltsware zu der übrigen verarbeiteten Ware zu. Soweit hier und auch nachfolgend auf den Wert der Vorbehaltsware abgestellt ist, ergibt sich diese aus unserem Fakturaort.

Erwirbt der Besteller das Alleineigentum an der neuen Sache gemäß § 947 Abs. 2 BGB, so besteht Einigkeit darüber, dass er uns im Verhältnis des Wertes der verarbeiteten bzw. verbundenen oder vermischten Vorbehaltsware Miteigentum an der neuen Sache einräumt und diese unentgeltlich für uns bewahrt. Wird die Vorbehaltsware zusammen mit anderen Waren, und zwar gleichgültig, ob ohne oder nach Verarbeitung, Verbindung oder Vermischung weiter veräußert, so gilt die oben vereinbarte Vorausabtretung nur in Höhe des Wertes der Vorbehaltsware, die zusammen mit den anderen Waren weiterveräußert wird. Wir verpflichten uns, die uns nach den vorstehenden Bestimmungen zustehenden Sicherungen auf Verlangen insoweit freizugeben, als der Wert die zu sichernden Forderungen mit 20 % übersteigt. Über Zwangsvollstreckungsmaßnahmen Dritter in die Vorbehaltsware oder die im Voraus abgetretenen Forderungen hat uns der Besteller unverzüglich unter Übergabe der für eine Intervention notwendigen Unterlagen zu unterrichten. Daraus entstehende Interventionskosten sind vom Besteller zu tragen. Der Besteller hat die Vorbehaltsware ausreichend gegen Feuer und Einbruchdiebstahl zu versichern und uns dies auf Verlangen nachzuweisen.

Mängelansprüche

Die Gewährleistungsfrist beträgt 1 Jahr ab Ablieferung der Ware. Dies gilt nicht, wenn der Kunde uns den Mangel nicht rechtzeitig angezeigt hat i.S.v. Ziffer 3 dieser Bestimmungen.

Wir leisten für Mängel der Ware zunächst nach unserer Wahl Gewähr durch Nachbesserung oder Ersatzlieferung. Bei Fehlschlagen von Nachbesserung oder Ersatzlieferung kann der Kunde Rückgängigmachung des Vertrages oder Herabsetzung der Vergütung verlangen. Bei einer nur geringfügigen Vertragswidrigkeit, insbesondere bei nur geringfügigen Mängeln, steht dem Kunden jedoch kein Rücktrittsrecht zu.

Der Kunde hat offensichtliche Mängel unverzüglich, spätestens innerhalb von 7 Tagen nach Eingang der Ware unter sofortiger Einstellung etwaiger Bearbeitung schriftlich anzuzeigen. Andernfalls ist die Gewährleistung ausgeschlossen. Zur Fristwahrung genügt die rechtzeitige Absendung. Den Besteller trifft die volle Beweislast für sämtliche Anspruchsvoraussetzungen, insbesondere für den Mangel selbst, für den Zeitpunkt der Feststellung des Mangels und für die Rechtzeitigkeit der Mängelrüge.

Mängel, die auch bei sorgfältiger Prüfung innerhalb dieser Frist nicht entdeckt werden können, sind unverzüglich nach Entdeckung schriftlich zu rügen.

Wählt der Kunde wegen eines Rechts- oder Sachmangels nach gescheiteter Nacherfüllung den Rücktritt vom Vertrag, steht ihm daneben kein Schadensersatzanspruch wegen des Mangels zu. Wählt der Kunde nach gescheiteter Nacherfüllung Schadensersatz, verbietet die Ware beim Kunden, wenn ihm dies zumutbar ist. Der Schadensersatz beschränkt sich auf die Differenz zwischen Kaufpreis und Wert der mangelhaften Sache. Dies gilt nicht, wenn wir die Vertragsverletzung arglistig verursacht haben.

Ware, für die wir Ersatz geleistet haben, geht in unser Eigentum über.

Ansprüche bestehen nicht für solche Schäden, die dadurch entstanden sind, dass der Kunde schuldhaft

- den Kaufgegenstand ungeschädigt behandelt oder überanspricht hat oder
- den Kaufgegenstand in einer nicht genehmigten Weise verändert hat oder
- die Vorschriften der Montage- oder Betriebsanleitung nicht befolgt hat oder
- die Rüge- und Zustellungspflicht gemäß vorstehender Ziffern 3 und 4 verletzt hat oder
- den Kaufgegenstand nach Mangelbestellung weiterbenutzt hat.

Natürlicher Verschleiß ist von der Gewährleistung ausgenommen.

Haftung

Bei leicht fahrlässigen Pflichtverletzungen beschränkt sich unsere Haftung auf den nach der Art der Ware vorhersehbaren, vertragstypischen, unmittelbaren Durchschnittsschaden. Dies gilt auch bei leicht fahrlässigen Pflichtverletzungen unserer gesetzlichen Vertreter oder Erfüllungsgehilfen. Bei leicht fahrlässiger Verletzung unwesentlicher Vertragspflichten haften wir nicht.

Die Haftung aufgrund zugesicherter Eigenschaften sowie aufgrund Produkthaftung bleibt unberührt, ebenso bei uns zurechenbaren Körper- oder Gesundheitsschäden oder bei Verlust des Lebens des Kunden. Schadensersatzansprüche des Kunden wegen eines Mangels verjähren nach einem Jahr ab Anlieferung der Ware. Dies gilt nicht, wenn uns grobes Verschulden vorwerfbar ist, sowie im Falle von uns zurechenbaren Körper- und Gesundheitsschäden oder bei Verlust des Lebens des Kunden.

Rücknahme

Ordnungsgemäß bestellte und gelieferte Ware wird grundsätzlich nicht zurückgenommen. Ausnahmen bilden Rücknahmen, die mit uns abgesprochen wurden. Zusätzlich müssen folgende Voraussetzungen erfüllt werden:

Die Produkte müssen von uns oder von einem unserer Werkslager direkt bezogen worden sein. Einwandfrei und unveränderter Zustand der Ware. Grundsätzlich ist die Rücknahme nur dann möglich, wenn die zur Rückgabe vorgesehenen Teile noch im Lieferprogramm sind.

Rückversand muss „frei Haus“ an unser Werk Ergersheim oder an das zuständige Werkslager unter Angabe von Lieferendeckdatum und -Nummer erfolgen.

Wertabschlag bei Rücknahme:

Im 1. Jahr nach Liefertag	/. 10 % vom Lieferpreis
Im 2. Jahr nach Liefertag	/. 25 % vom Lieferpreis
zwischen 3. und 5. Jahr nach Liefertag	/. 50 % vom Lieferpreis
Ware älter als 5 Jahre	keine Rücknahme möglich.

Nach Erhalt der Teile erfolgt die technische Überprüfung und Erstellung der Gutschrift unter Berücksichtigung eines etwaigen Wertabschlages. Frachtkosten, sofern sie für den ursprünglichen Versand für uns entstanden sind, vermindern den Restwert.

Schutzrechte

Bei kundenspezifischen Sonderanfertigungen haftet der Besteller uns für die Freiheit von Schutzrechten Dritter der in Auftrag gegebenen Lieferungen, stellt uns von etwaigen Ansprüchen Dritter frei und hat uns etwaigen aus einer Verletzung dieser Pflicht resultierenden Schaden zu ersetzen.

Unsere Entwürfe und Konstruktionsvorschläge sind vertraulich zu behandeln und dürfen nicht an Dritte weitergegeben werden.

Sämtliche Zeichnungen, Konstruktionspläne und Muster, die dem Besteller zugegangen sind, bleiben unser geistiges Eigentum.

Erfüllungsort, Gerichtsstand, sonstige Vereinbarungen

Als Beschaffenheit der Ware gilt grundsätzlich nur die Produktbeschreibung des Herstellers als vereinbart. Öffentliche Äußerungen, Anpreisungen oder Werbung des Herstellers stellen daneben keine vertragsgemäße Beschaffenheitsangabe der Ware dar. Proben und Muster gelten als annähernde Anschauungsstücke für Qualität, Abmessungen und Farbe. Rechtsansprüche können hieraus nicht abgeleitet werden. Technische Änderungen sowie Änderungen in Form, Farbe und/oder Gewicht bleiben im Rahmen des Zumutbaren vorbehalten.

Erhält der Kunde eine mangelhafte Montageanleitung, sind wir lediglich zur Lieferung einer mangelfreien Montageanleitung verpflichtet und dies auch nur dann, wenn der Mangel der Montageanleitung der ordnungsgemäßen Montage entgegensteht.

Garantien im Rechtssinne erhält der Kunde durch uns nicht; Herstellergarantien bleiben hiervon unberührt.

Erfüllungsort für unsere Lieferungen ist bei Lieferung ab Werk das Lieferwerk, bei Lieferung ab Lager das Lager. Erfüllungsort für alle Zahlungen ist Fürth / Bayern.

Ausschließlicher Gerichtsstand für alle Streitigkeiten aus diesem Vertrag ist Fürth / Bayern, Deutschland. Dies gilt auch für evtl. Scheck- und Wechselklagen.

Es gilt das Recht der Bundesrepublik Deutschland. Die Bestimmungen des UN-Kaufrechts finden keine Anwendung. Es ist allein der Text der deutschsprachigen Fassung dieser Allgemeinen Geschäftsbedingungen maßgeblich.

Ergänzend gelten die mit den jeweiligen Preislisten bekannt gegebenen Sonderbedingungen unserer Produkte.

Der Besteller ist selbst dafür verantwortlich, die Eignung von Waren für den beabsichtigten Verwendungszweck zu prüfen.

Hinweis gemäß Bundesdatenschutzgesetz:

Die zur Auftragsabwicklung erforderlichen Kundendaten werden gespeichert.

Stand: 10/2007

GENERAL TERMS AND CONDITIONS OF SALE AND DELIVERY

General Provisions

The provisions of the contract between us and our customers solely underlie these general terms and conditions. Our offers are exclusively meant for entrepreneurs in the sense of Section 14 BGB (Civil Code). Deviating business terms of the client, even if they are known to us, will not become a part of the contract. Our offers are always subject to change without notice. Our General Terms and Conditions of Sale and Delivery are considered accepted upon placement of order, at the latest upon receipt of goods. These General Terms and Conditions of Sale and Delivery apply in the case of repeated business relations also for all future transactions. Should individual provisions be or become completely or partially ineffective, then the validity of the other provisions will thereby not be affected. The regulation which is completely or partially ineffective shall be substituted by a regulation whose economic success will be as close as possible to the ineffective one.

Prices

By ordering merchandise the client bindingly declares that he wants to buy the merchandise ordered. He will be bound to this statement for two weeks. We are entitled to accept the offer of a contract underlying the order within two weeks upon receipt of the latter by us. The acceptance may be declared in writing, electronically, or by delivery to the client.

The obligations in electronic commerce according to Section 312e par. 1 sentence 1 Nos. 1 to 3 and sentence 2 BGB are excluded.

The conclusion of the contract takes place subject to the correct and timely delivery by our sub suppliers to us. This applies only in case we are not responsible for the non-delivery, especially in case of the conclusion of a congruent hedging business transaction with our sub suppliers. The client will be informed about the nonavailability of the product without delay, and the equivalent, insofar as already paid, will be reimbursed immediately.

All contractual financial obligations are to be fulfilled solely in EURO.

Prices are understood to be net as ex factory or supply depot. Freight, packing and import costs, customs duties and other additional taxes are payable by the purchaser. Domestic deliveries within Germany are free of freight and packing from a net value of merchandise of 600,- EUR upward.

Period of Delivery and Supply Commitment

Our written or electronic order confirmation is decisive for extent, type, and date of the delivery. Partial shipments are allowed.

A liability in meeting delivery deadlines determined as binding shall only be accepted under the condition of undisturbed flow of operations and distribution, in particular in cases of acts of God and other disruptive events at our facilities or those of our suppliers or transport contractors, for example operational or traffic disruptions, fire, flooding, labour-, energy-, or traffic shortages, strikes, lockouts, official measures as well as technical or technological situations that considerably aggravate the execution of the contract, release us from liability in punctual delivery or give us the right to stop delivery without obligation for subsequent delivery.

If not agreed otherwise, we have the right to deliver earlier than the delivery deadline.

Delivery deadlines are considered met when the goods have left the works or dispatch depot or the purchaser has received notice by expiration of the deadline of our readiness to deliver. Subsequent alteration of contract is cause for a reasonable extension of delivery deadlines.

In the case of contracts whose performance consists of several deliveries, non-performance, defective or delayed performance of one delivery remains without influence upon the other deliveries of the contract. Default of payments, application for the opening of an insolvency proceeding, handing in of a state meant in lieu of an oath of disclosure in accordance with § 807 ZPO, temporary shortage of liquid funds, or public knowledge of a considerable deterioration of the financial circumstances of the purchaser entitles us to stop deliveries immediately and to deny performance of current contracts. At the same time we are entitled to make immediately due and payable those accounts receivable from the ordering company which are not due yet.

Shipment, Passage of Risk

Packing, shipping route and method of transportation remain at our discretion unless special agreements have been made.

The risk of accidental loss and accidental deterioration of the merchandise will pass over to the buyer upon handing it over, in case of a mail order purchase upon delivery of the matter to the forwarding agent, the carrier, or another person or institution determined to execute the shipment. If the buyer is overdue in accepting, this will be equal to a handing over of the merchandise.

Merchandise out of call orders shall be accepted within 3 months after issuance of the acknowledgement of order, unless otherwise agreed.

Insurance against breakage and transportation risks is only taken out upon special request and will be billed.

Customs duties and other expenses, also the costs for payment of the necessary papers for import into country of destination, are payable by the purchaser.

Payments, Terms of Payment

Invoicing are payable:

- within 14 days from date of invoice with 2 % cash discount of the invoice end value;
- within 30 days from date of invoice without cash discount of the invoice end value.

Cash discount is only granted when all payment commitments out of earlier deliveries have been fulfilled and the invoice amount has been punctually paid to us in cash or has been credited to our account by the aforementioned due dates. The drawing of a bill of exchange can thus not lead to the granting of a cash discount. In case of cashless payment, especially when a cheque is submitted, the date of the credit entry will be decisive. A cash discount cannot be granted in the case of payment or credit entry with limiting conditions or any other restrictions. The purchaser assumes all risks of method of payment. Invoices for tools are subject to immediate payment without cash discount.

Bills of exchange and checks are only accepted on account of payment. Corresponding credit entries are made only under the limiting condition of correct receipt of the complete amount due. We reserve the right to take in external or own acceptances. Costs and discount expenses are payable by the purchaser. We assume no responsibility for submission and protest. Protest imposed against the purchaser's own bills of exchange or non-immediate repayment of protested external bills of exchange entitles us to return all bills in circulation. At the same time we are entitled to make immediately due and payable those accounts receivable from the ordering company which are not due yet. Post-dated checks are not accepted. Interest on defaulted payment of 8% over the discount rate of the German Central Bank referred to in § 247 BGB shall be charged in the case of missed payment dates. The right of assertion of further damages caused by delayed performance and other claims remains reserved.

Advance and part payments are not subject to interest. The purchaser is only entitled to offset or withhold payment if his counterclaim is undisputed or has been determined legally binding. The client may execute a right of retention only if his counter claim is based on the same contractual relationship.

Customer and invoice numbers are to be given by the purchaser when invoices are balanced. Delays or incorrect booking resulting from failure to do so are payable by the purchaser.

Retention of Ownership, Factoring

The delivered goods remain our property until payment of all claims has been received. The purchaser has the right to resell the proviso goods within the scope of proper and orderly course of business; however, a pledge or transfer by way of security is not permissible. The purchaser is required to ensure our rights in the case of resale of proviso goods on credit.

The accounts receivable by the ordering company based on its resale of the merchandise subject to reservation are transferred to us in the amount of the invoice value at this time already. We hereby agree to accept this transfer. Regardless of the assignment, the purchaser retains the right to collect payment under the condition that he fulfils his responsibilities to us according to the underlying contractual relationship and does not fall into financial decline. Otherwise the purchaser must provide the information about the assignment necessary for collection upon our demand and notify his debtors of the assignment. In this case we reserve the right to collect the accounts receivable by ourselves.

A possible finishing or processing of the merchandise sold subject to reservation will always take place on our behalf and by order for us, without any obligations resulting for us from this, however. In the case of processing of proviso goods with other goods not belonging to us, we are entitled to the co-owner portion of the resulting product corresponding to the value of the proviso goods in relation to the other processed goods. Insofar as here and following the value of the proviso goods is referred to, it results out of our invoice value.

Should the purchaser acquire sole ownership of the new product according to § 947 paragraph 2 BGB, so is it agreed that the purchaser grants co-ownership in the proportion of the value of the processed, attached, or mixed proviso goods, and that he protects these rights free of charge.

In the case of resale of the proviso goods together with other goods, regardless of with or without processing, attachment or mixing, the assignment in advance agreed to above is valid only to the extent of the value of proviso goods that were resold together with the other goods. We are obligated to release on demand the securities entitled as provided above, when the value exceeds secured payments by 20 %. The purchaser must immediately notify us and provide the material necessary for an intervention in the case of compulsory execution by third parties against the proviso goods or the advance assigned claims. Intervention costs resulting there from are payable by the purchaser.

The ordering company has to adequately insure the merchandise sold subject to reservation against fire and burglary and has to prove this to us on demand.

Warranty

The warranty period is 1 year from the dispatch of the merchandise. This will not apply if the client has not reported the defect to us in time in the meaning of item 3 of these provisions.

First of all, we shall remedy a defect or make a substitute delivery at our discretion. In case of failure to rectify defects or to substitute deliver, the customer can demand rescission of the contract or reduction of compensation. In case there is only a minor contract violation, especially if there are only minor defects, the client will not have the right of cancellation, however.

The customer must notify us in writing of any obvious flaws immediately, at the latest within 7 days after receipt of goods, and must refrain from any eventual working of protested goods. Otherwise the warranty is excluded. The timely dispatch will suffice for the observance of the warranty deadline. The full burden of proof for all claim prerequisites rests with the ordering company, especially for the defect itself, for the date of the establishment of the defect, and for the timeliness of the complaint about the defect. Defects which could not be ascertained within this time span despite careful inspection are to be reported to us in writing immediately upon discovery.

If the client opts for a withdrawal from the contract because of a legal imperfection or a physical defect after a failed subsequent fulfillment, then he will not be additionally entitled to a claim for compensation because of the defect. If, after a failed subsequent fulfillment, the client opts for the compensation of the damage, then the merchandise will remain with the client if this can be expected of him.

The compensation is restricted to the difference between the purchase price and the value of the defective product. This will not apply if we caused the contract violation maliciously. Goods which we have replaced by us become our property.

Claims cannot be made for damages that resulted from the customer culpably

- improperly handling or overstressing the purchased item or
- altering the purchased item in an unapproved manner or
- not following the instructions of the mounting or operating manual or
- not observing the complaint and delivery responsibility according to Points 3 and 4 above or
- further using the purchased item after ascertaining the defect.

Natural wear and tear is excepted from the warranty.

Liability

In case of simply negligent violations of obligations our liability will be restricted to an average damage predictable for the type of merchandise, typical for such a contract, and immediate. This also applies in case of simply negligent duty violations of our legal representatives or employees. We shall not be held liable in case of a simply negligent violation of nonessential contract obligations.

The liability by virtue of warranted properties as well as due to product liability remains unaffected; the same applies in case of bodily harm or health impairment attributable to us or in the event of loss of life of the client.

Compensation claims of the client because of a defect will superannuate after one year from the delivery of the merchandise to the client. This will not apply if we may be charged with gross negligence as well as in case of bodily harm or health impairment attributable to us or in the event of loss of life of the client.

Returns

Properly ordered and delivered goods shall in broad principle not be taken back. Returns that have been arranged with us are the exception. In addition, the following prerequisites must be met:

The products must have been acquired directly from us or from one of our works depots. Flawless and unaltered condition of the goods. In principle, return shall only be possible when the articles in question are still in the program of delivery.

Return shipment must be „free domicile“ to our Ergersheim works or to the appropriate works depot with accompanying delivery note date and number.

Value reduction for returns:

in the first year after delivery date	.10 % of the contract price
in the second year after delivery date	.25 % of the contract price
between the 3rd & the 5th year after deliv. date	.50 % of the contract price
merchandise over five years old	no return possible

Technical inspection and completion of the credit slip shall be carried out under consideration of eventual value reduction upon receipt of the articles. Freight costs, insofar as any occurred to us for the original shipping, reduce the remaining value.

Industrial Property Rights

The ordering company is held liable to us for the exemption from industrial protection rights of third parties on custom-made articles ordered, indemnifies us against any possible claims of third parties and has to reimburse any damage to us possibly resulting from a violation of this obligation.

Our designs and design proposals are to be kept confidential and may not be passed on to third parties. All drawings, construction plans, and samples which the ordering company has received, will remain our intellectual property.

Place of Fulfillment and Jurisdiction, Other Agreements

On principle, the product description of the manufacturer is understood to be decisive for the characteristics of the goods. Public statements, sales talks, or advertisements made apart from this do not represent a contractual description of the characteristics of the goods. Samples and specimens serve as approximate illustrative articles for quality, measurements and colour. Legal claims cannot be inferred from this. Technical changes as well as alterations in shape, colour, and/or weight are reserved within the scope of what may be expected of a client.

If the client receives a faulty assembly instruction, we shall only be obliged to furnish a faultless assembly instruction, and this only if the fault of the assembly instruction is in contradiction with a proper assembly. The client does not receive warranties in the legal meaning from us; warranties of the manufacturers will remain unaffected by this.

Place of fulfillment for our deliveries ex works is the delivery works, for delivery ex storage the warehouse. Place of fulfillment for all payments is Fuert / Bavaria.

The exclusive place of jurisdiction for all litigations from this contract is Fuert / Bavaria, Germany.

This applies to lawsuits based on a cheque or bill of exchange, too.

The Law of the Federal Republic of Germany is governing these provisions. The provisions of the UN Purchase Law are not applied. The wording of the German-language version of our „General Terms and Conditions of Sale and Delivery“ only is decisive for these General Business Terms.

Additionally applicable are the special terms of our products published with the appropriate price lists.

The ordering company itself is responsible to examine the goods for the intended final usage.

German law (BDSG) requires us to inform you that all data of our clients are electronically saved.

status: 10/2007



Mekra Lang GmbH & Co. KG hat diesen Katalog sorgfältig verfasst. Das Unternehmen enthebt sich jeglicher Verantwortung für eventuelle Fehler oder Auslassungen hinsichtlich Schemen, Zeichnungen, Übereinstimmung mit O.E. Codes usw. und behält sich das Recht vor, ohne Ankündigung, am Inhalt Veränderungen vorzunehmen. Anmerkungen, Fehlerhinweise und weitere Anregungen seitens der Kunden werden gerne entgegen genommen, um die nächste Ausgabe des Kataloges effizienter zu gestalten.

Die Vervielfältigung, auch teilweise, des urheberrechtlich geschützten Inhalts des vorliegenden Kataloges ist ohne schriftliche Genehmigung durch die Mekra Lang GmbH & Co. KG untersagt.

Sämtliche im Katalog genannten Sachnummern der Fahrzeughersteller und deren Markennamen sowie Prüfnummern anderer Spiegelhersteller dienen lediglich zu Vergleichszwecken.



Mekra Lang GmbH & Co. KG has devoted its best attention to the editing of this catalogue; it nevertheless declines any responsibility for possible mistakes or omissions regarding figures, drawings, correspondence with O.E. codes etc. and it reserves the right to modify the contents without prior notice. Users' comments, reports of inaccuracies or any other suggestions which may in any way improve the next edition of this catalogue are warmly welcomed.

It is forbidden to reproduce, even partially, the contents of this catalogue without prior written consent of Mekra Lang GmbH & Co. KG, who will protect its right in accordance with the law.

All vehicle manufacturers' reference numbers, mentioned in the catalogue, as well as their brand names and approval numbers of other mirror manufacturers are only for identification purposes.

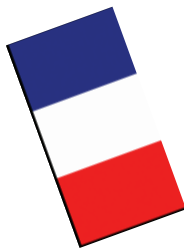

Mekra Lang GmbH & Co. KG a soigné avec une attention particulière la rédaction de ce catalogue; elle décline cependant toute responsabilité pour toute erreur ou omission éventuelle dans les schémas, les dessins, les correspondances avec les codes O.E., etc. et se réserve le droit d'en modifier le contenu sans obligation de communication préalable.

Les commentaires, les signalisations d'inexactitudes et toute autre suggestion des utilisateurs susceptibles de rendre la prochaine rédaction du catalogue plus efficace seront particulièrement appréciés.

Il est interdit de reproduire même partiellement le contenu de ce catalogue sans autorisation écrite préalable de Mekra Lang GmbH & Co. KG, qui protégera ses droits selon les termes de la loi.

Toutes les références d'origine ainsi que les noms des constructeurs des véhicules et les références (& numéros d'homologation) d'autres fabricants de rétroviseurs cités dans ce catalogue ne servent qu'à l'identification des produits.



Mekra Lang GmbH & Co. KG teve especial atenção à edição deste catálogo; não obstante, declina toda a responsabilidade por possíveis erros ou a omissões a respeito das fotos, desenhos, correspondência com códigos originais etc., e se reserva o direito de modificar seu conteúdo sem aviso prévio. Os comentários dos usuários, relatórios de inexactidão ou qualquer outra sugestão que puder melhorar a edição seguinte deste catálogo, serão bem-vindas.

É extremamente proibido a reprodução parcial ou total do conteúdo deste catálogo sem a expressa autorização por escrito de Mekra Lang GmbH & Co. KG.

Todos os números de referência e novos nomes dos fabricantes dos veículos, mencionados neste catálogo, bem como números de aprovação (homologação) dos fabricantes dos retrovisores apenas para fins de identificação.

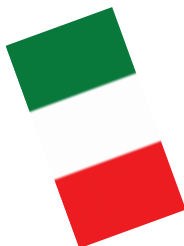

Mekra Lang GmbH & Co. KG ha curato con particolare attenzione la stesura del presente catalogo; declina comunque ogni responsabilità per eventuali errori od omissioni relativi a schemi, disegni, corrispondenze con i codici O.E. ecc. e si riserva il diritto di apportare modifiche al contenuto senza l'obbligo di dare preventiva comunicazione.

Sono particolarmente graditi, da parte degli utenti, commenti, segnalazioni di inesattezze e qualsiasi altro suggerimento atto a rendere più efficace la prossima edizione del catalogo.

È vietata la riproduzione, anche parziale, del contenuto del presente catalogo senza preventiva autorizzazione scritta della Mekra Lang GmbH & Co. KG, che tutelerà i propri diritti a termine di legge.

Tutti i riferimenti originali ed i marchi dei costruttori di veicoli, così come i numeri di omologazione di altri produttori di specchi hanno solo valore indicativo ai fini della identificazione del prodotto.



Mekra Lang GmbH & Co. KG ha cuidado con especial atención la redacción del presente catálogo; de todas maneras declina toda responsabilidad por ventuales errores u omisiones relativos a esquemas, diseños, correspondencia con los códigos O.E., etc., y se reserva el derecho de aportar modificaciones al contenido sin la obligación de previo aviso. Se agradecen especialmente los comentarios, las indicaciones de inexactitudes y cualquier otra sugerencia por parte de los usuarios que sean útiles para hacer más eficaz la próxima edición del catálogo.

Está prohibida la reproducción, total o parcial, del contenido del presente catálogo sin previa autorización escrita de Mekra Lang GmbH & Co. KG, que protegerá sus propios derechos con arreglo a la ley.

Todas las referencias de los fabricantes de vehículos, así como las marcas - mencionados en el catálogo - y números de homologaciones de otros fabricantes de retrovisores son únicamente con fines de identificación.



Mekra Lang GmbH & Co. KG har gjort sitt yttersta för att innehålllet i denna katalog ska vara så korrekt som möjligt. Mekra Lang reserverar sig dock för eventuella felaktigheter eller utelämnande av uppgifter vad det gäller ritningar bilder eller dylikt. Mekra Lang förbehåller sig rätten till ändringar utan förvarning. Läsarens kommentarer eller rapporter om felaktigheter alternativt förslag på sådant som kan förbättras till nästa utgåva, är varmt välkomna.

Det är förbjudet att helt eller delvis reproducera innehålllet i denna katalog utan skriftligt medgivande från Mekra Lang GmbH & Co. KG.

Specifika fordons- eller spegeltillverkarens referensnummer, varumärken eller EG-typgodkännandenummer är endast omnämnda för att underlätta identifikation.

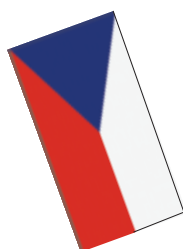

Mekra Lang GmbH & Co. KG pečlivě vyhotovila tento katalog, avšak odmítá jakoukoliv odpovědnost za možné chyby nebo vymechní obsahu, pokud jde o schémata, výkresy, shodu s originálními kódy atd. a vyhrazuje si právo bez předchozího upozornění měnit obsah. Poznámky, upozornění na chyby a další podněty ze strany zákazníků, které by zdokonalily další vydání tohoto katalogu jsou vítány.

Kopírování i částečné kopírování autorským právem chráněného obsahu tohoto katalogu je bez písemného souhlasu firmy Mekra Lang GmbH & Co. KG zakázáno.

Všechna výrobní čísla výrobců vozidel včetně jejich značek a homologační čísla jiných výrobců zpětných zrcadel uvedené v tomto katalogu slouží pouze k porovnávání.

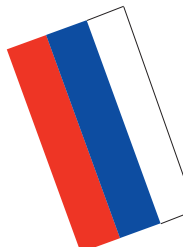

Фирма **Mekra Lang GmbH & Co KG** тщательно подготовила данный каталог. Фирма не несет ответственности за возможные ошибки или пропуски что касается схем и рисунков и соответствия с O.E., номерами и т.д., и оставляет за собой право без предварительного оглашения изменять содержание.

Мы охотно учтём замечания, информацию об ошибках и прочие пожелания со стороны клиентов, чтобы более эффективно организовать следующий выпуск каталога.

Все вышеперечисленные в каталоге номера производителей автомобилей, автомобильные марки, а также контрольные номера ЕС других производителей зеркал приведены для сравнения.



Mekra Lang GmbH & Co. KG bu katalogu oluşturmak için büyük bir özen göstermiş, OE kodlarındaki, çizimlerdeki, şekillerdeki, vb. olası hatalar için sorumluluğunu en aza indirmeye çalışmış ve haber vermeden değışiklik yapma hakkını saklı tutmuştur. Kullanıcıların yorumları, bildirecekleri tutarsızlıklar veya geliştirici önerileri bir sonraki basım için oldukça faydalı olacaktır.

Bu katalogun Mekra Lang GmbH & Co. KG'nin yazılı onayı olmadan tekrar basılması, kısmen veya tamamen kullanılması yasaktır. Böyle bir durumda Mekra Lang GmbH & Co. KG kanunî olarak haklarını savunacaktır.

Katalogda bahsedilen tüm üreticilerin referans numaraları, markaları ve diğer ayna üreticilerinin homologasyon numaraları sadece betimleme maksatlıdır.

**MEKRA Lang GmbH & Co.KG****Fertigung / Produktion**

Buchheimer Straße 4
D-91465 Ergersheim
Fon + 49 - 98 47 - 989-0
Fax + 49 - 98 47 - 989-200
info@mekra.de
www.mekra.de

Verwaltung und Sitz / Head office

Alfred-Nobel-Str. 55-57
D-90765 Fürth
Fon + 49 - 911 - 97 62-0
Fax + 49 - 911 - 97 62-120
info@mekra.de
www.mekra.de

**Lang MEKRA North America**

101 Tillessen Boulevard
Ridgeway, SC 29130
U.S.A.
Fon + 1 - 803 337 5264
Fax + 1 - 803 337 5265
sales@lang-mekra.com
www.lang-mekra.com

**MEKRA Lang Otomotiv Yan Sanayi A.S.**

Baskent Organize Sanayi Bölgesi
19. Cad. 160 Ada 11 Parsel
Maliköy Temelli
06910 Ankara
Türkiye
Fon + 90 - 312 640 12 16
Fax + 90 - 312 640 12 25
mekratrurkey@mekra-turkey.com
www.mekra-turkey.com

**Lang MEKRA do Brasil Ltda.**

Estrada do Péron 20 95
Distrito Industrial do Eden
Sorocaba (SP) 18013-972
Brazil
Fon + 55 - 15 3325 3320
Fax + 55 - 15 3325 3966
info@mekra.com.br
www.langmekra.com.br

**MEKRA France**

26 - 32 Avenue des Frères Lumière
Bâtiment G
78190 TRAPPES
France
Fon +33 - 1 - 30.47.43.85
Fax +33 - 1 - 30.47.45.16
info@mekra.fr
www.mekra.fr

**MEKRA UK Limited**

17, Willowbrook Road
Hambridge Trading Estate
Worthing, West Sussex
BN 148NA
United Kingdom
Fon + 44 (0) 1903 - 206106
Fax + 44 (0) 1903 - 214395
info@mekra.co.uk
www.mekra.co.uk

**MEKRA Lang International ČR spol. s.r.o.**

Družstevní 185
330 08 Zruč
Česka Republika
Fon + 420 - 377 824 893
Fax + 420 - 377 824 893
mekra@mekra.cz
www.mekra.cz

**Convex Hungaria Kft.**

Terv u. 10
9400 Sopron
Hungary
Fon + 36 - 99 512 750
Fax + 36 - 99 512 760
info@convex.hu
www.convex.hu

**Lang-Mekra Mexico S de RL de CV**

Av. Sendero Norte 510 bodega L
(Parque Ad Hoc) Col. Balcones de
Anahuac San Nicolas de los Garza,
N.L. CP. 66422
Mexico
Fon +1 803 337 4907
Fax +1 803 337 5265



DIN EN ISO 9001: 2000
ISO TS 16949: 2002
DIN EN ISO 14001: 2004

**Shanghai MEKRA Lang**

Vehicle Mirror Co. Ltd.
Ganxiang Town
Jinshan District
201518 Shanghai
P.R. China
Fon + 86 - 21 - 57 20 26 90 ext. 215
Fax + 86 - 21 - 57 20 26 92
service@mekra-lang.com.cn
www.mekra-lang.com.cn

Changchun MEKRA Lang

Fawer Vehicle Mirror Co. Ltd.
No. 1601, Guanggu Street
National High-Tech Industries
Development Area
Vehicle Industry Garden
Changchun / P.C 130012
P.R. China
Fon + 86 - 431 8555 6163
Fax + 86 - 431 8555 6159
changchun@mekra-lang.com

**Suntech Co. Ltd.**

1310, 13F, Byucksan Kyungin
Digital Valley II, 481-10
Gasam Dong, Kumchon Ku
Seoul City 153-783
Korea
Fon + 82 - 2 - 2113 - 1566
Fax + 82 - 2 - 2113 - 1580
info@sun-tech.com
www.sun-tech.com

**Mekra Global Mirrors Liaison office**

India Regus Business Centre,
Level-4, Augusta Point,
DLF Golf course Road,
Gurgaon-122001, Haryana
India
Fon +91-124-4354000
Fax +91-124-4354001
neeraj.vashishth@mekra.in
www.mekra.in

