

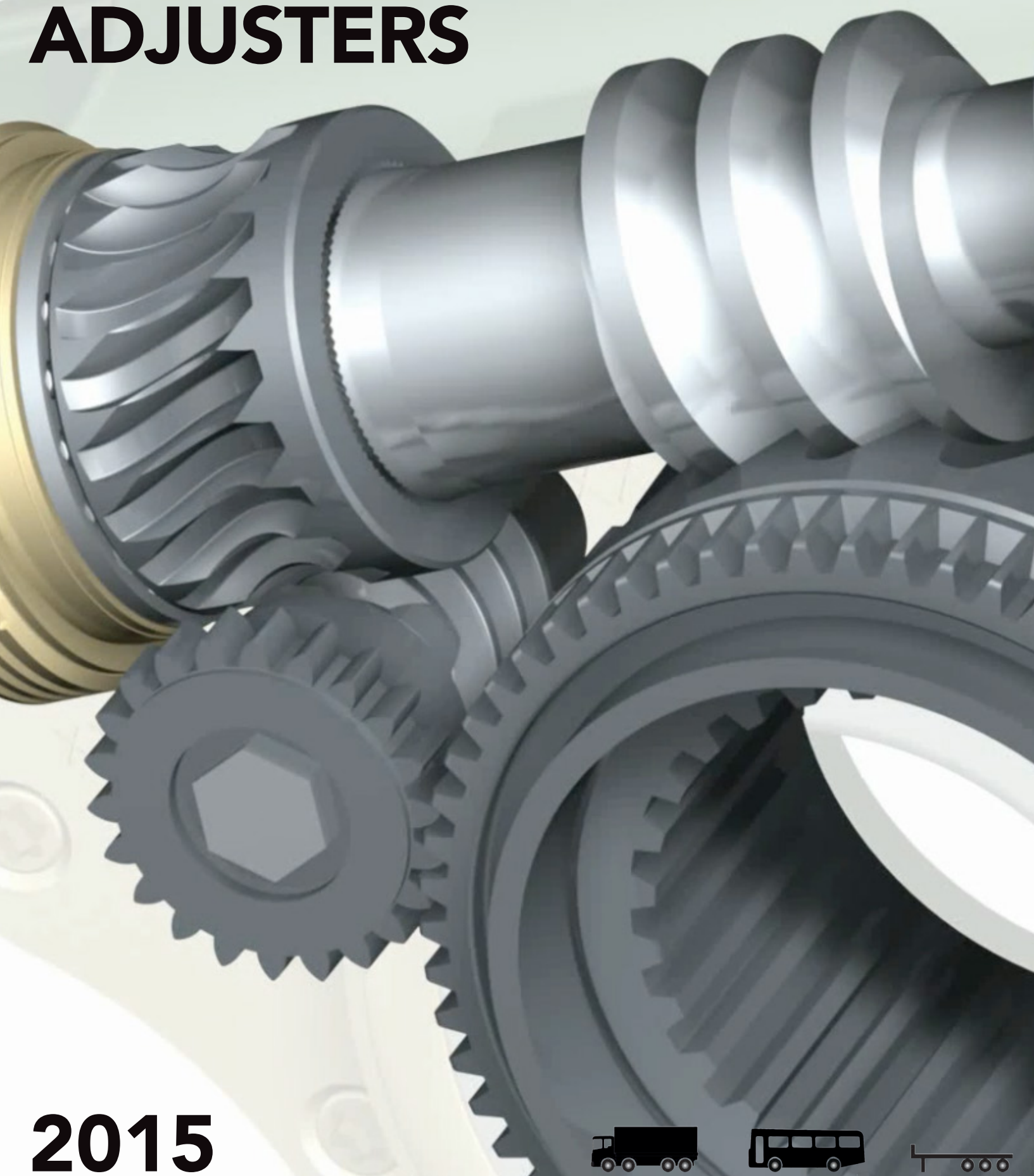

MEI SLACK ADJUSTERS



2015





CONTENTS

About MEI	4
What It Does	5
How It Works	6
Glossary	10
Identification	11
Trailer	12
Truck & Bus	28
Extended Range	99
Kits	100
Fitting	102
Maintenance	106
Warranty	108
Cross Reference	110
Notes	128
Terms & Conditions	131



ABOUT MEI



MEI (Madras Engineering Industries) factories are all certified to TS16949 by TÜV and vertical integration is key to our philosophy:

MEI Foundry Pillaipakkam	SG Iron casting for Housings
MEI Facility Ambattur	Critical component Production
MEI Facility Mahindra City	Assembly Lines
MEI Facility Maraimalai Nagar	Research & Development Centre

Producing slack adjusters since 1982, MEI is a specialist manufacturer, supplying to OEM and our Distributors throughout the world. Our state of the art in-house R&D centre continues to make patented improvements to our products, meaning we can offer industry leading warranty and full technical support.



WHAT IT DOES

The Automatic Slack Adjuster (ASA) is a vital part of the foundation brake. It acts as a lever, forming the connection between the actuator and the camshaft. The function of the ASA is to compensate for wear in both brake lining and brake drum while maintaining a constant stroke of the actuator.

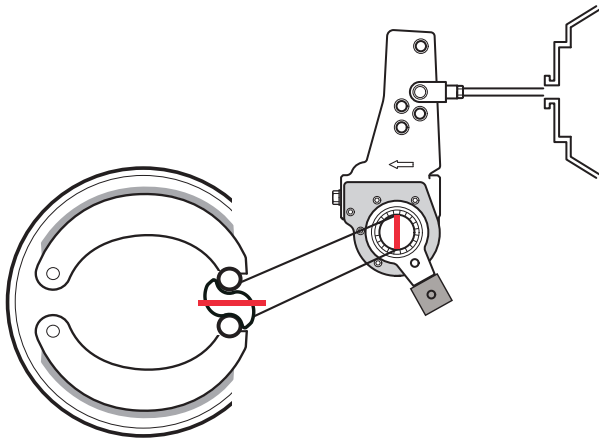

When the brake is applied the actuator moves the ASA forward. The worm wheel rotates the camshaft, in turn moving the brake lining toward the brake drum. This is the pre-set running clearance.

The ASA continues to move until the brake lining touches the drum. If lining and/or drum has worn the ASA mechanism engages and accounts for slack or wear in the system. This is the excess clearance for which adjustment is made.

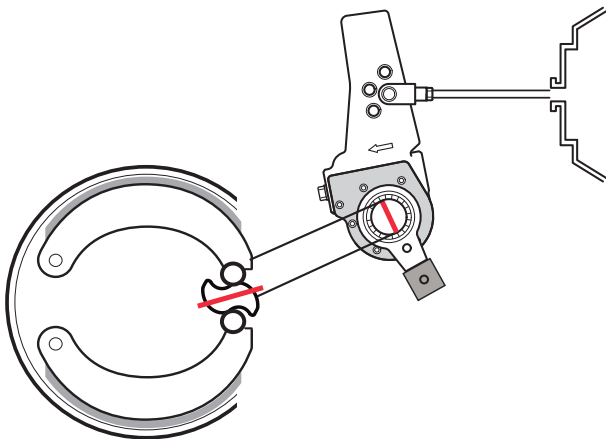

When the brake lining contacts the drum, the reacting force causes the ASA mechanism to dis-engage. This dis-engagement means adjustment is not made for any elasticity within the foundation brake.

When the brake is released the reacting force drops and the ASA mechanism re-engages. If excess clearance (wear) is in the system, the worm wheel in the mechanism will not return to its original position - it will have indexed. This means the camshaft will also have indexed, keeping a constant gap between lining and drum.

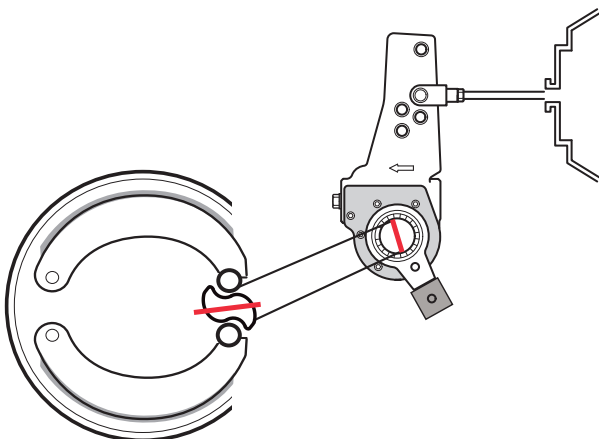

The ASA, however, does return to its original position, ensuring constant stroke is maintained.

HOW IT WORKS

Automatic Slack Adjuster

Parts Listing

- 1 Rivet
- 2 Bearing Retainer
- 3 Thrust Bearing
- 4 O Ring
- 5 Conical Clutch Assembly
 - 5a Conical Clutch Housing
 - 5b Wrap Spring
 - 5c Pinion
 - 5d Thrust Bush
- 6 Worm Shaft
- 7 Grease Nipple
- 8 Housing
- 9 Clevis Bush
- 10 Spring Seat
- 11 Coil Spring
- 12 Spring Retainer
- 13 Rack
- 14 Return Springs
 - 14a Outer
 - 14b Inner
- 15 O Ring Outer
- 16 Worm Wheel
- 17 O Ring Inner
- 18 Gasket
- 19 Control Unit Assembly
 - 19a Cover Plate
 - 19b Control Arm
 - 19c Control Disc
- 20 Cover Plate Screw
- 21 Grommet
- 22 Welch Plug

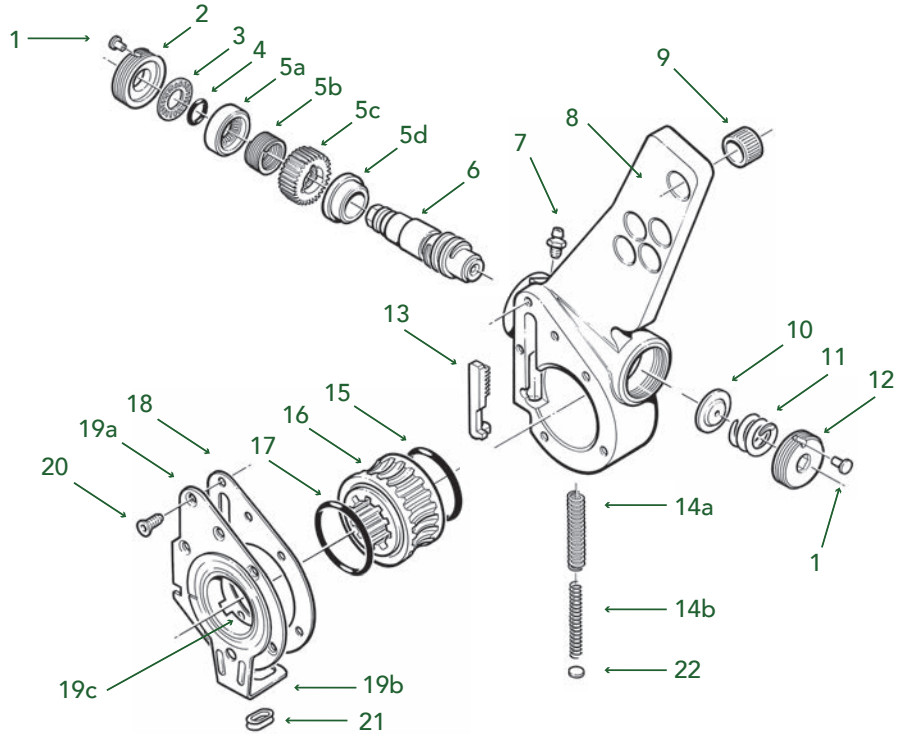

Start Position

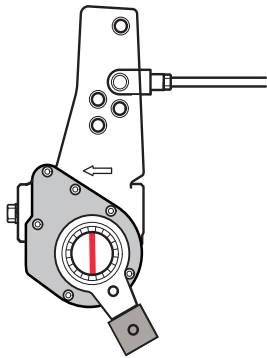

Pre-Set Running Clearance Phase

In the start position the toe of the rack touches the top of the cut-out. On the forward stroke the ASA rotates. The rotation of the ASA means the toe of the rack changes position and now touches the bottom of the cut-out. This is the Pre-Set Running Clearance – the rotation of the ASA when no adjustment occurs.

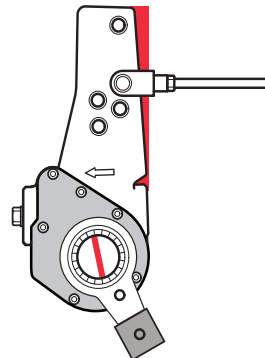

Forward Stroke



Excess Clearance Phase

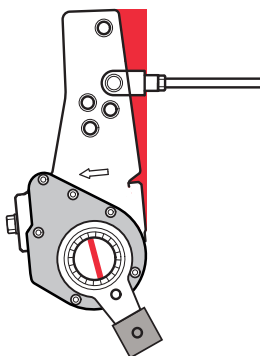

If there is Excess Clearance or wear, the stroke will be longer and the ASA will rotate further. The rack will remain touching the bottom of the cut-out throughout the forward stroke, therefore rotating the pinion in the slip direction of the one-way clutch assembly. As the pinion slips in this direction, the one-way clutch ensures that even though the conical clutch is engaged, the worm shaft does not rotate. The rotation of the pinion in this phase directly corresponds to the adjustment which will be made.

Forward Stroke

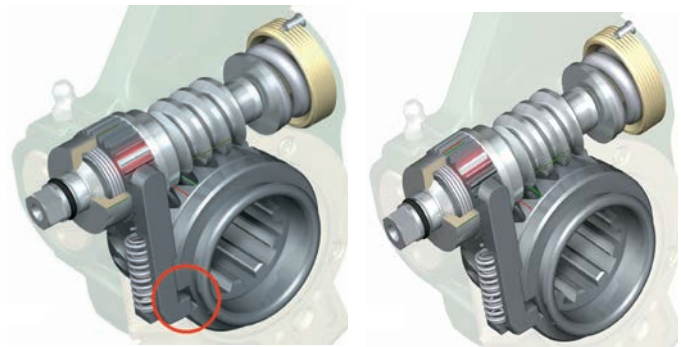

To see the full ASA and S-ASA animations please visit our website

HOW IT WORKS

Elasticity Phase

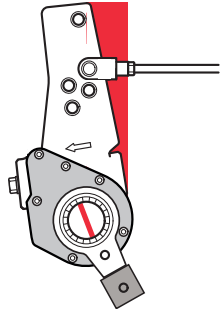

When the brake linings touch the brake drum the ASA continues to rotate due to Elasticity in the brake. The increasing camshaft torque acts through the worm wheel and worm shaft, the coil spring is compressed and the conical clutch disengages. The rack continues to turn the one-way clutch assembly, which now rotates freely being disengaged from the worm shaft.

Forward Stroke

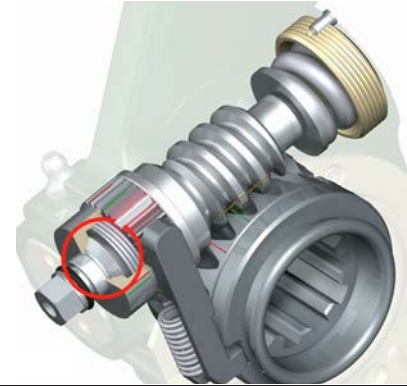

Elasticity Phase

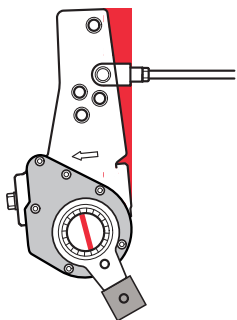

On the return stroke the ASA starts to rotate in the opposite direction. The rack is held down, keeping the same position in the cut-out, and rotates the one way clutch assembly, still disengaged from the worm shaft, in the opposite direction. As the brake linings move away from the brake drum the camshaft torque drops, the coil spring de-compresses and the conical clutch re-engages.

Return Stroke

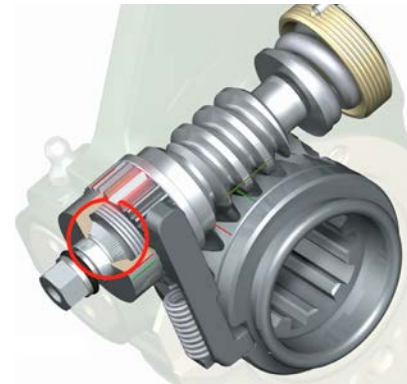

Pre-Set Running Clearance Phase

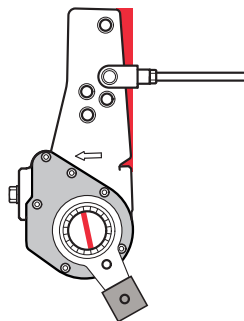

The rack moves with the housing during this phase, therefore the rack does not rotate the pinion. As the ASA rotates through the return stroke, the toe of the rack will move from the bottom to the top of the cut-out.

Return Stroke

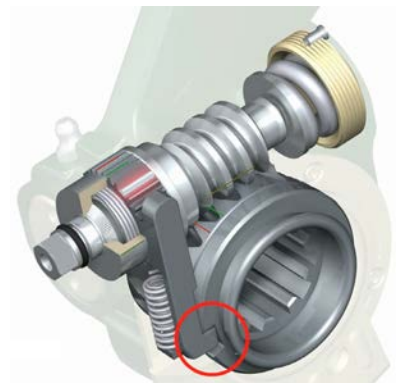

Adjustment Phase

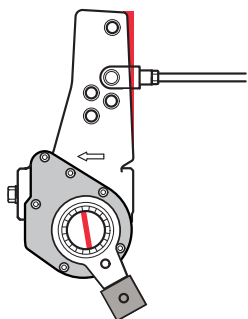

The ASA continues to rotate through the return stroke. Held by the cut-out, the rack drives the one-way clutch assembly. The conical clutch is engaged, so the worm shaft rotates and indexes the worm wheel within the housing. This in turn indexes the camshaft to a new position, meaning the Excess Clearance (slack) has been Adjusted and the pre-set running clearance maintained.

End Position

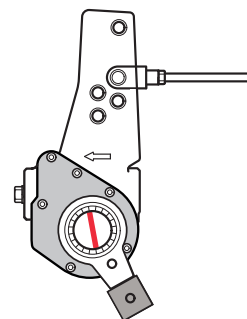

Return Stroke

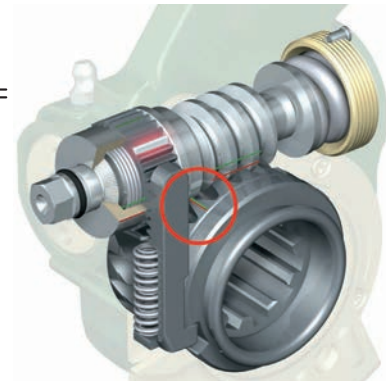

The ASA must return to its original position for Adjustment to be made. The Adjustment ratio of the ASA mechanism is such that Excess Clearance is not always adjusted for in a single brake application. Over a number of brake applications the correct clearance will be maintained.

HOW IT WORKS

Self Setting Automatic Slack Adjuster

Parts List

- 1 Rivet
- 2 Bearing Retainer
- 3 Thrust Bearing
- 4 O Ring
- 5 Clutch Worm Wheel
- 6 Main Worm Shaft
- 7 Housing
- 8 Grease Nipple
- 9 Clevis Bush
- 10 Spring Seat
- 11 Coil Spring
- 12 Spring Retainer
- 13 Regulator Assembly
 - 13a Regulator Pinion
 - 13b Regulator Worm Shaft
- 14 Retaining Spring
- 15 O Ring Outer
- 16 Main Worm Wheel
- 17 O Ring Inner
- 18 Gasket
- 19 Cover Plate Assembly
 - 19a Cover Plate
 - 19b Control Arm
 - 19c Control Worm Gear
- 20 Cover Plate Screw
- 21 Grommet

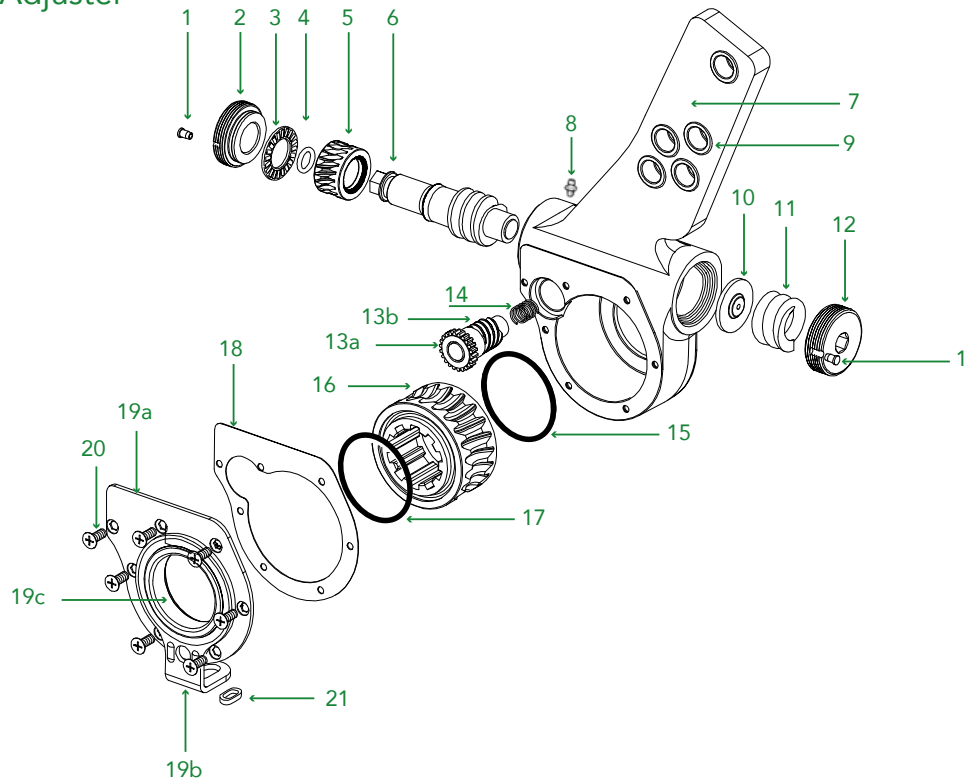

Start Position

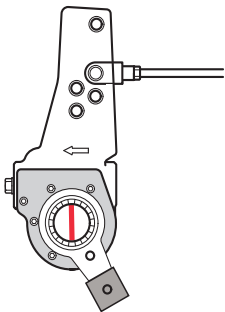

Pre-Set Running Clearance Phase

In the start position the cut-out slot in the regulator is open. On the forward stroke the S-ASA rotates. The rotation of the S-ASA closes the cut-out as the regulator pinion rotates but the regulator worm shaft is held by the engaged conical clutch. This is the Pre-Set Running Clearance – the S-ASA rotates but no adjustment occurs.

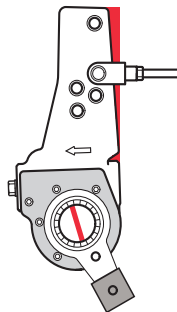

Forward Stroke

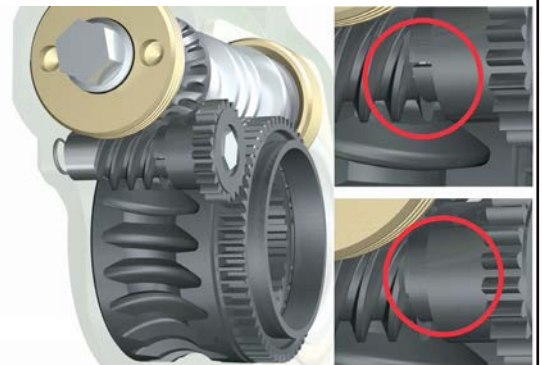

Excess Clearance Phase

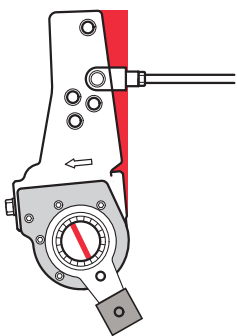

If there is Excess Clearance or wear, the stroke will be longer and the S-ASA will rotate further. With the slot now closed, the one-way clutch in the regulator rotates in the slip direction. As the conical clutch is engaged the regulator worm shaft and clutch worm wheel do not rotate. The rotation of the one-way clutch in the slip direction directly corresponds to the adjustment which will be made.

Forward Stroke

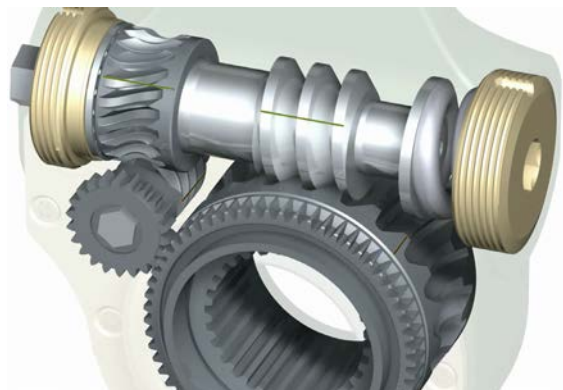

HOW IT WORKS

Elasticity Phase

Forward Stroke

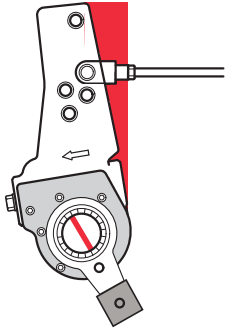

When the brake linings touch the brake drum the S-ASA continues to rotate due to Elasticity in the brake. The increasing camshaft torque acts through the main worm wheel and main worm shaft, the coil spring is compressed and the conical clutch disengages. The regulator worm shaft and clutch worm wheel then rotate freely because the one-way clutch is no longer under load and does not slip.

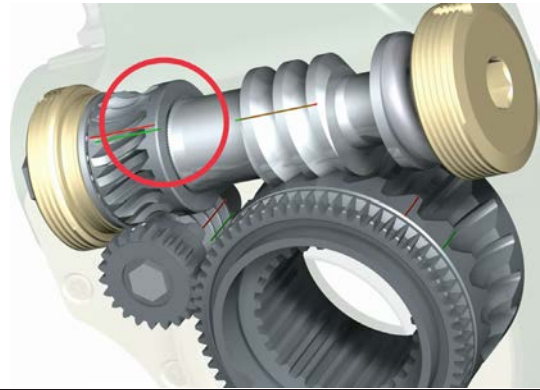

Elasticity Phase

Return Stroke

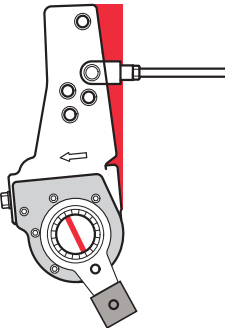

On the return stroke the S-ASA starts to rotate in the opposite direction. The conical clutch is still disengaged from the worm shaft so the regulator worm shaft and clutch worm wheel rotate freely. As the brake linings move away from the brake drum the camshaft torque drops, the coil spring de-compresses and the conical clutch re-engages.

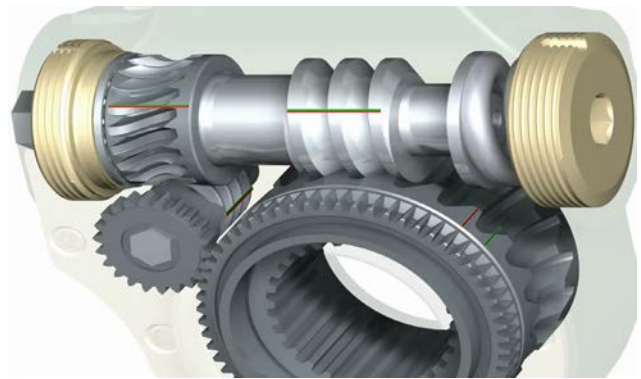

Pre-Set Running Clearance Phase

Return Stroke

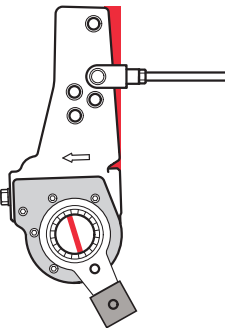

The S-ASA continues to rotate. The regulator worm shaft is held by the re-engaged conical clutch but the regulator pinion rotates, opening the slot.

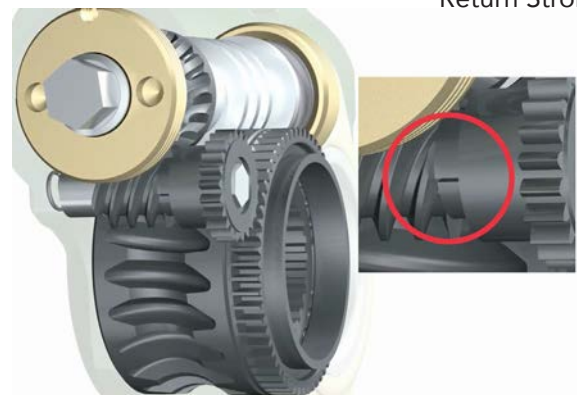

Adjustment Phase

End Position

Return Stroke

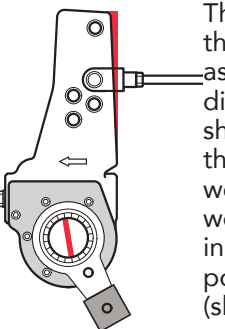

The S-ASA continues to rotate through the return stroke. The one-way clutch assembly is now rotating in the non-slip direction and drives the regulator worm shaft, rotating the clutch worm wheel. As the conical clutch is engaged the main worm shaft rotates and indexes the main worm wheel within the housing. This in turn indexes the camshaft to a new position, meaning the Excess Clearance (slack) has been Adjusted and the pre-set running clearance maintained.

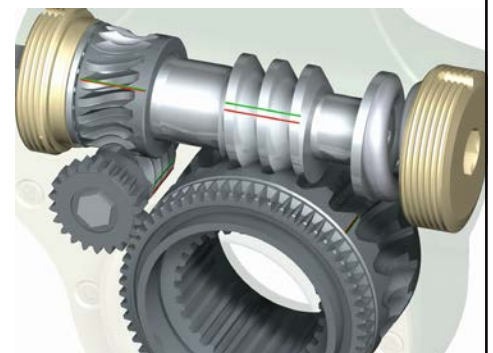
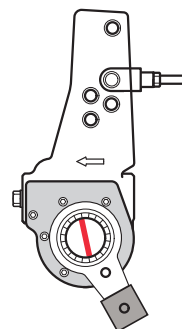

The S-ASA must return to its original position for Adjustment to be made. The Adjustment ratio of the S-ASA mechanism is such that Excess Clearance is not always adjusted for in a single brake application. Over a number of brake applications the correct clearance will be maintained.

GLOSSARY

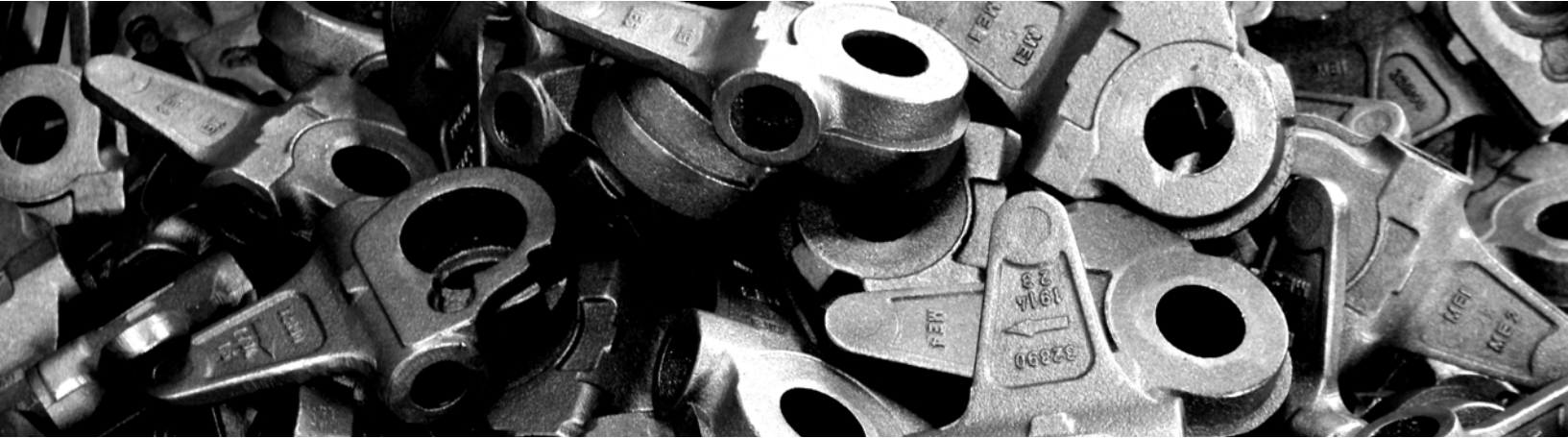

ASA	Automatic Slack Adjuster
Adjustment	Method whereby the Automatic Slack Adjuster maintains the correct Pre-Set Clearance
Alpha Angle	The installation angle of the Control Arm on the Slack Adjuster
Anchor Bracket	Used with Quick-Fit Control Arms
Anchor Pin	Used with Control Arms which bolt to the Anchor Point
Anchor Point	The bracket which connects the Control Arm of the Slack Adjuster to the vehicle
Camshaft	Connects the Slack Adjuster worm wheel to the brake shoes
Clevis Bush	The bush in the Housing where the actuator mates with the Slack Adjuster
Control Arm	The rotating arm connecting the Cover Plate to the Anchor Point
Control Unit	Combination of Cover Plate, Control Arm, Alpha Angle (ASA only) and Pre-Set Clearance
Cover Plate	Metal pressing which is screwed on to the Housing to protect the Mechanism
Fitting Kit	Loose parts supplied with the Slack Adjuster
Grease Nipple	All MEI Slack Adjusters are fitted with Grease Nipple to lubricate the Mechanism
Grommet	Plastic insert housed in Peg Bolt type Control Arms
Hex Nut	The 12mm nut which rotates as the Mechanism adjusts, being part of the Worm Shaft
Housing	Cast section which contains the Mechanism and extends to hold the Clevis Bush
Inclination	With Cover Plate facing and Hex Nut on your left, this is the angle of the Housing, taken from the vertical
MSA	Manual Slack Adjuster
Mechanism	The internal components of the Slack Adjuster which maintain the Pre-Set Clearance of the brake system
OEM	Original Equipment Manufacturer
Offset	With Hex Nut facing, this is the distance from centre of the Hex Nut to centre of the Housing where the Clevis Bush sits, taken from the vertical
Peg Bolt	Used with Control Arms incorporating a Grommet in the Anchor Point
Pre-Set Clearance	The distance between brake lining and brake drum specified by the vehicle manufacturer
Quick-Fit	Common Anchor Point type on trailers where the Control Arm sits in the slot of the Anchor Bracket
S-ASA	Self-setting Automatic Slack Adjuster
Spline	The mating teeth of the Camshaft and Slack Adjuster
Wear Indicator	Pointer which is fixed to and rotates with the Camshaft, showing brake lining wear
Worm Shaft	Part of the Mechanism which mates with the Worm Wheel and includes the Hex Nut
Worm Wheel	Part of the Mechanism which mates with the Worm Shaft and Camshaft

IDENTIFICATION

MEI Automatic Slack Adjusters (ASA) and Self-setting Automatic Slack adjusters (S-ASA) are identified by the part number which is marked on the cover plate.

After a long life in service or while still on the vehicle, it can be difficult to read the information on the cover plate. Therefore the following measurements can be taken to assist identification:

The cast housing has an identification mark, for MEI ASA this begins with T (eg T-32) and for MEI S-ASA this begins with S (eg S-43).

The cast housing can be straight or offset (A).

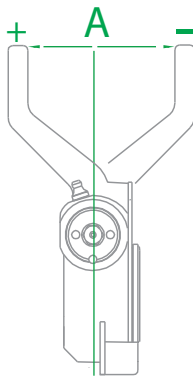

It can also be straight or inclined (B).

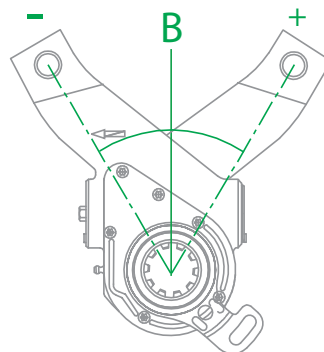

On MEI ASA the control arm angle can be checked (C).*

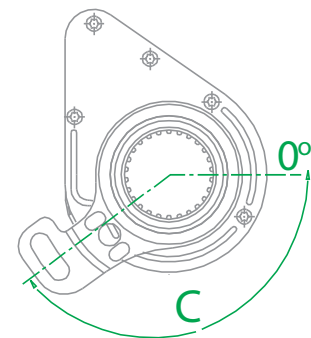

On both ASA and S-ASA the Anchor Point type will be Quick-Fit, Peg Bolt, or Anchor Pin (D).

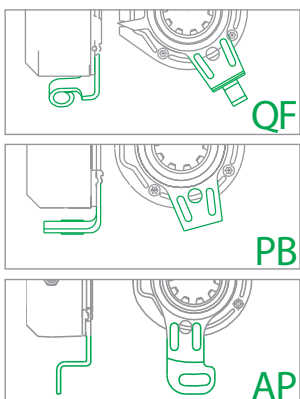

The number of teeth on the worm wheel which mates with the camshaft can be counted (E).

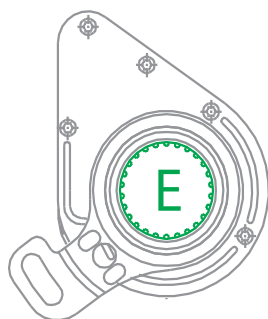

The clevis bush internal diameter (ID) can be measured (F).

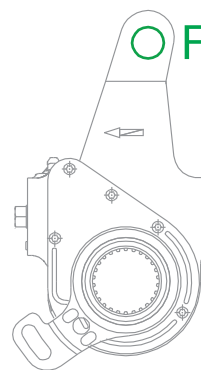

The distance from the centre of the worm wheel to the centre of the clevis hole can be checked (G).

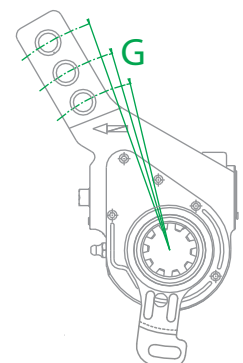

With the above information any MEI slack adjuster can be identified. In addition it is always useful to know the vehicle application and which wheel end the adjuster is fitted to.

*** For S-ASA this is Not Applicable as the control arm will work from any position within the working arc of the control arm.**

TRAILER

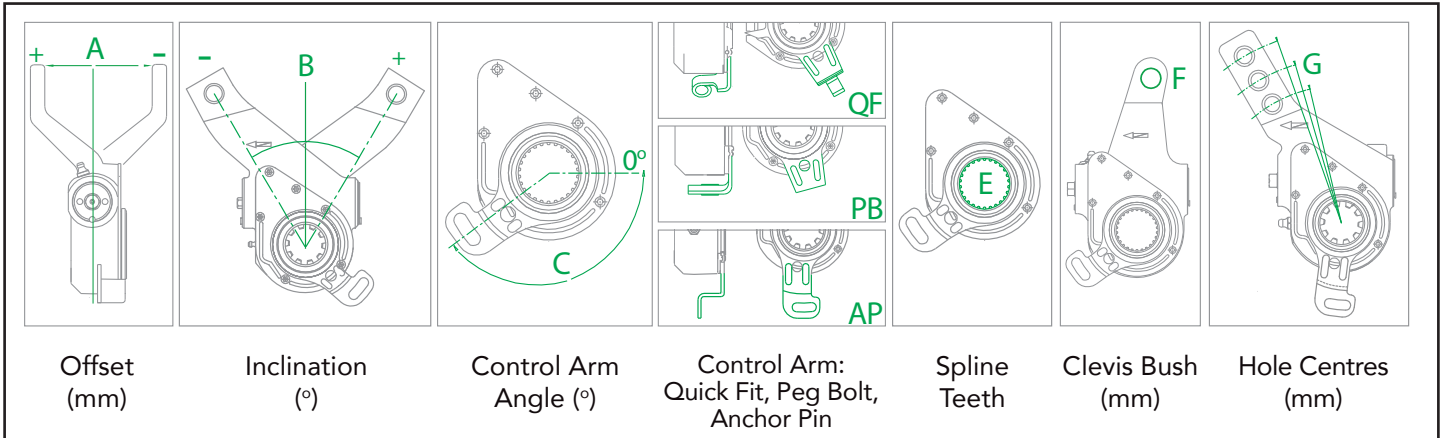

4W1000		Meritor					
Haldex: 72788							
OEM: 21229249							
Supplied With: K1000							
Axle Side:L&R				Other Side: 4W1000			
A	B	C	D	E	F		
0	+20	60°	QF	10	14.2		
G1	G2	G3	G4	G5	G6	G7	
115	127	140	153	205			

4W1005		BPW					
Haldex: 72875							
OEM: 0517482212							
Supplied With: K1030							
Axle Side:L&R				Other Side: 4W1005			
A	B	C	D	E	F		
0	+20	50°	QF	10	14.2		
G1	G2	G3	G4	G5	G6	G7	
120	135	150	165	180	250		

4W1010		BPW					
Haldex: 72876							
OEM: 0517482122							
Supplied With: K1030							
Axle Side:L&R				Other Side: 4W1010			
A	B	C	D	E	F		
0	+20	110°	QF	10	14.2		
G1	G2	G3	G4	G5	G6	G7	
120	135	150	165	180	250		

4W1015		Trailor					
Haldex: 79023							
OEM: 9002105							
Supplied With: K1020							
Axle Side:L&R				Other Side: 4W1015			
A	B	C	D	E	F		
0	+20	130°	QF	10	14.2		
G1	G2	G3	G4	G5	G6	G7	
125	150	180	210				

4W1020		Fruehauf					
Haldex: 79022							
OEM: AJB0743001							
Supplied With: K1020							
Axle Side:L&R				Other Side: 4W1020			
A	B	C	D	E	F		
0	+20	130°	QF	37	14.2		
G1	G2	G3	G4	G5	G6	G7	
105	129	153	215				

4W1025		SMB					
Haldex: 79004							
OEM: MO02416							
Supplied With: K1020							
Axle Side:L&R				Other Side: 4W1025			
A	B	C	D	E	F		
0	+20	130°	QF	10	14.2		
G1	G2	G3	G4	G5	G6	G7	
105	129	153	215				

TRAILER

4W1030

SAF



Haldex: 79005						
OEM: 4175024900						
Supplied With: K1030						
Axle Side:L&R			Other Side: 4W1030			
A	B	C	D	E	F	
0	+20	130°	QF	10	14.2	
G1	G2	G3	G4	G5	G6	G7
105	125	140	155	180	250	

4W1035

SAF



Haldex: 72948						
OEM: 4175039400						
Supplied With: K1030						
Axle Side:L&R			Other Side: 4W1035			
A	B	C	D	E	F	
0	+20	130°	QF	10	14.2	
G1	G2	G3	G4	G5	G6	G7
125	150	180	210	250		

4W1040

SAF



Haldex: 79035						
OEM: 4175024800						
Supplied With: K1030						
Axle Side:L&R			Other Side: 4W1040			
A	B	C	D	E	F	
0	+20	130°	QF	10	14.2	
G1	G2	G3	G4	G5	G6	G7
105	127	152	181	215		

4W1050

Fruehauf



Haldex: 72266						
OEM: AJB0092001						
Supplied With: K0270						
Axle Side:L&R			Other Side: 4W1050			
A	B	C	D	E	F	
0	+20	130°	PB	37	14.2	
G1	G2	G3	G4	G5	G6	G7
105	127	152	215			

4W1055

Meritor



Haldex: 72261						
OEM: 21217569						
Supplied With: K0270						
Axle Side:L&R			Other Side: 4W1055			
A	B	C	D	E	F	
0	+20	130°	PB	10	14.2	
G1	G2	G3	G4	G5	G6	G7
105	127	152	178	215		

4W1060

York



Haldex: 72268						
OEM: Y537146						
Supplied With: K0270						
Axle Side:L&R			Other Side: 4W1060			
A	B	C	D	E	F	
0	+20	130°	PB	10	12.9	
G1	G2	G3	G4	G5	G6	G7
105	127	152	178	215		

4W1065

Meritor



Haldex: 72256						
OEM:						
Supplied With: K0270						
Axle Side:L&R			Other Side: 4W1065			
A	B	C	D	E	F	
0	0	0°	PB	10	12.9	
G1	G2	G3	G4	G5	G6	G7
127	152	178	203			

4W1070

Meritor



Haldex: 72359						
OEM: 21217568						
Supplied With: K0270						
Axle Side:L&R			Other Side: 4W1070			
A	B	C	D	E	F	
0	+20	130°	PB	10	14.2	
G1	G2	G3	G4	G5	G6	G7
120	140	215				

TRAILER

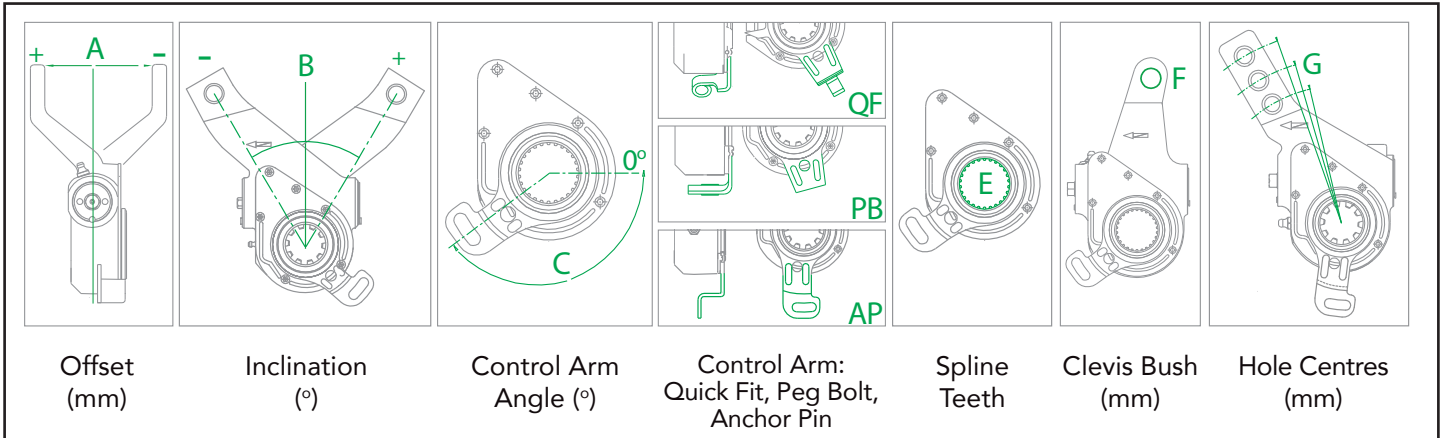

4W1075 SAF



Haldex: 72250						
OEM: 4175008501						
Supplied With: K0270						
Axle Side:L&R			Other Side: 4W1075			
A	B	C	D	E	F	
0	+20	130°	PB	10	14.2	
G1	G2	G3	G4	G5	G6	G7
125	150	180	210	250		

4W1080 SAF



Haldex: 70949						
OEM: 3434350202						
Supplied With:						
Axle Side:L&R			Other Side: 4W1080			
A	B	C	D	E	F	
0	+133	280°	AP	10	14.2	
G1	G2	G3	G4	G5	G6	G7
127	152	178	203			

4W1085 Assali Stufen



Haldex: 79097						
OEM: 21229280						
Supplied With:						
Axle Side:L			Other Side: 4W1090			
A	B	C	D	E	F	
-16	0	145°	AP	10	14.2	
G1	G2	G3	G4	G5	G6	G7
125	150	180				

4W1090 Assali Stufen



Haldex: 79098						
OEM: 21229281						
Supplied With:						
Axle Side:R			Other Side: 4W1085			
A	B	C	D	E	F	
+16	0	145°	AP	10	14.2	
G1	G2	G3	G4	G5	G6	G7
125	150	180				

4W1100 BPW



Haldex: 72282						
OEM:						
Supplied With: K0270						
Axle Side:L&R			Other Side: 4W1100			
A	B	C	D	E	F	
0	+20	115°	PB	10	14.2	
G1	G2	G3	G4	G5	G6	G7
105	127	152	178	215		

4W1105 BPW



Haldex: 72253						
OEM:						
Supplied With: K0270						
Axle Side:L&R			Other Side: 4W1105			
A	B	C	D	E	F	
0	+20	130°	PB	10	14.2	
G1	G2	G3	G4	G5	G6	G7
120	150	180	250			

TRAILER

4W1110

SAF



Haldex: 72239						
OEM: 4175014000						
Supplied With:						
Axle Side:R			Other Side: 4W1160			
A	B	C	D	E	F	
+25	-30	358°	AP	10	14.2	
G1	G2	G3	G4	G5	G6	G7
127	152	178				

4W1115

Assali Stefen



Haldex: 70802						
OEM: 21229250						
Supplied With: K0270						
Axle Side:R			Other Side: 4W1120			
A	B	C	D	E	F	
-38	0	110°	PB	10	14.2	
G1	G2	G3	G4	G5	G6	G7
152	178	203				

4W1120

Assali Stefen



Haldex: 70803						
OEM: 21229251						
Supplied With: K0270						
Axle Side:L			Other Side: 4W1115			
A	B	C	D	E	F	
+38	0	110°	PB	10	14.2	
G1	G2	G3	G4	G5	G6	G7
152	178	203				

4W1125

BPW



Haldex: 79502						
OEM:						
Supplied With:						
Axle Side:L&R			Other Side: 4W1125			
A	B	C	D	E	F	
0	0	20°	AP	10	14.2	
G1	G2	G3	G4	G5	G6	G7
125	150	180	210			

4W1130

SAF



Haldex: 79318						
OEM: 4175015000						
Supplied With:						
Axle Side:R			Other Side: 4W1135			
A	B	C	D	E	F	
+25	-30	90°	AP	10	14.2	
G1	G2	G3	G4	G5	G6	G7
127	152	178				

4W1135

SAF



Haldex: 79317						
OEM: 4175014900						
Supplied With:						
Axle Side:L			Other Side: 4W1130			
A	B	C	D	E	F	
-25	-30	90°	AP	10	14.2	
G1	G2	G3	G4	G5	G6	G7
127	152	178				

4W1140

SAF



Haldex: 79338						
OEM: 4175025200						
Supplied With: K0270						
Axle Side:			Other Side: 4W1145			
A	B	C	D	E	F	
-45	0	130°	PB	10	14.2	
G1	G2	G3	G4	G5	G6	G7
127	152					

4W1145

SAF



Haldex: 79339						
OEM: 4175025100						
Supplied With: K0270						
Axle Side:			Other Side: 4W1140			
A	B	C	D	E	F	
+45	0	130°	PB	10	14.2	
G1	G2	G3	G4	G5	G6	G7
127	152					

TRAILER

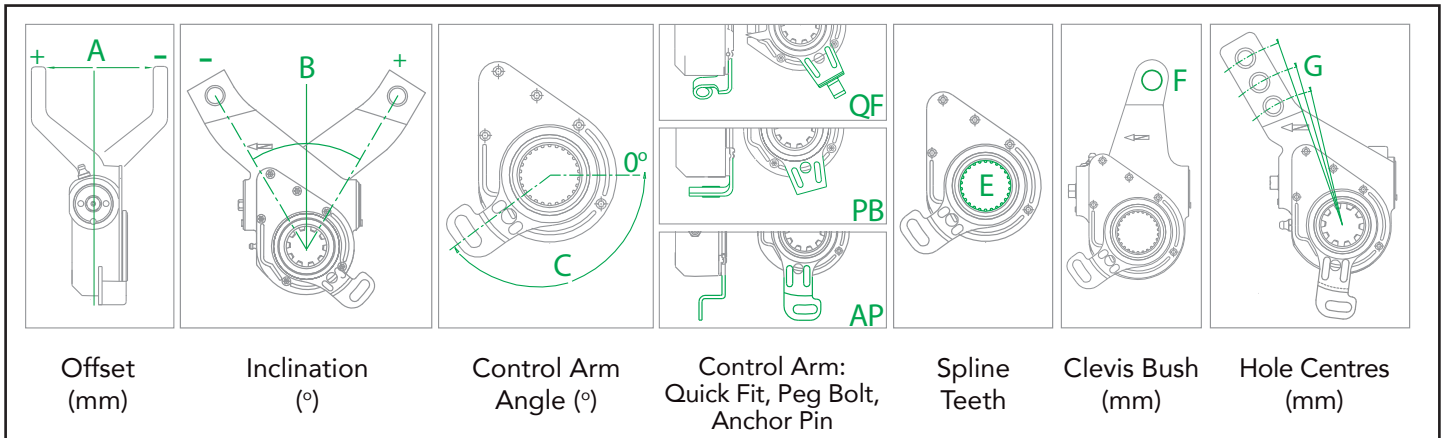

4W1150 **York**



Haldex: 72255						
OEM:						
Supplied With: K0270						
Axle Side:L&R			Other Side: 4W1150			
A	B	C	D	E	F	
0	+20	80°	PB	10	12.9	
G1	G2	G3	G4	G5	G6	G7
105	127	152	178	215		

4W1160 **SAF**



Haldex: 72238						
OEM: 4175013900						
Supplied With:						
Axle Side:L			Other Side: 4W1110			
A	B	C	D	E	F	
-25	-30	358°	AP	10	14.2	
G1	G2	G3	G4	G5	G6	G7
127	152	178				

4W1165 **Fruehauf**



Haldex: 72104						
OEM:						
Supplied With: K0270						
Axle Side:L&R			Other Side: 4W1165			
A	B	C	D	E	F	
0	+20	21°	PB	37	14.2	
G1	G2	G3	G4	G5	G6	G7
105	127	152	210			

4W1170 **Assali Stefen**



Haldex: 79183						
OEM: 21229290						
Supplied With: K0270						
Axle Side:L&R			Other Side: 4W1170			
A	B	C	D	E	F	
0	+20	130°	PB	10	14.2	
G1	G2	G3	G4	G5	G6	G7
127	140	152				

4W1175 **Fruehauf**



Haldex: 72103						
OEM: CF351148						
Supplied With: K0270						
Axle Side:L&R			Other Side: 4W1175			
A	B	C	D	E	F	
0	0	0°	PB	10	14.2	
G1	G2	G3	G4	G5	G6	G7
120	140	200				

4W1180 **Assali Stefen**



Haldex: 79160						
OEM: 21229289						
Supplied With: K0270						
Axle Side:L&R			Other Side: 4W1180			
A	B	C	D	E	F	
0	+20	130°	PB	10	14.2	
G1	G2	G3	G4	G5	G6	G7
105	125	140	155	180	250	

TRAILER

4W1185

Assali Stefen



Haldex: 79051						
OEM: 21229287						
Supplied With:						
Axle Side:L&R			Other Side: 4W1185			
A	B	C	D	E	F	
0	+20	145°	AP	10	14.2	
G1	G2	G3	G4	G5	G6	G7
105	127	152	178	215		

4W1205

Assali Stefen



Haldex: 79028						
OEM: 21229285						
Supplied With:						
Axle Side:R			Other Side: 4W1210			
A	B	C	D	E	F	
-38	0	145°	AP	10	14.2	
G1	G2	G3	G4	G5	G6	G7
152	178	203				

4W1210

Assali Stefen



Haldex: 79029						
OEM: 21229286						
Supplied With:						
Axle Side:L			Other Side: 4W1205			
A	B	C	D	E	F	
+38	0	145°	AP	10	14.2	
G1	G2	G3	G4	G5	G6	G7
152	178	203				

4W1215

BPW



Haldex: 70969						
OEM: 0517454420						
Supplied With: K0270						
Axle Side:R			Other Side: 4W1220			
A	B	C	D	E	F	
-29	0	110°	PB	10	14.2	
G1	G2	G3	G4	G5	G6	G7
150	175	200				

4W1220

BPW



Haldex: 70970						
OEM: 0517454410						
Supplied With: K0270						
Axle Side:L			Other Side: 4W1215			
A	B	C	D	E	F	
+29	0	110°	PB	10	14.2	
G1	G2	G3	G4	G5	G6	G7
150	175	200				

4W1225

Battaglini



Haldex: 79030						
OEM:						
Supplied With: K0270						
Axle Side:			Other Side: 4W1230			
A	B	C	D	E	F	
-29	0	90°	PB	10	14.2	
G1	G2	G3	G4	G5	G6	G7
150	180					

4W1230

Battaglini



Haldex: 79031						
OEM:						
Supplied With: K0270						
Axle Side:			Other Side: 4W1225			
A	B	C	D	E	F	
+29	0	90°	PB	10	14.2	
G1	G2	G3	G4	G5	G6	G7
150	180					

4W1235

Dong-A



Haldex: 79685						
OEM:						
Supplied With: K1000						
Axle Side:L&R			Other Side: 4W1235			
A	B	C	D	E	F	
0	0	60°	QF	10	12.9	
G1	G2	G3	G4	G5	G6	G7
140	165	190				

TRAILER

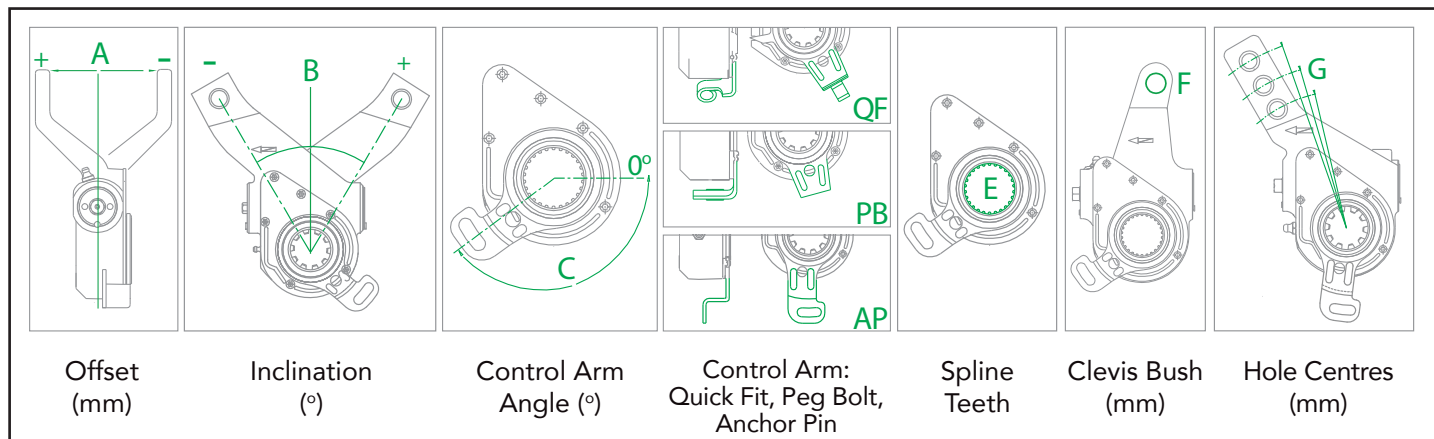

4W1240 **Cardi**



Haldex: 79111						
OEM:						
Supplied With: K1000						
Axle Side:L&R			Other Side: 4W1240			
A	B	C	D	E	F	
0	+20	60°	QF	8	14.2	
G1	G2	G3	G4	G5	G6	G7
120	135	150	165	180	250	

4W1245 **Assali Stefen**



Haldex: 79090						
OEM: 21229288						
Supplied With: K0270						
Axle Side:			Other Side: 4W1245			
A	B	C	D	E	F	
0	0	12°	PB	10	14.2	
G1	G2	G3	G4	G5	G6	G7
127	152	178	203			

4W1265 **SAF**



Haldex: 79006						
OEM: 4175024700						
Supplied With: K1030						
Axle Side:L&R			Other Side: 4W1265			
A	B	C	D	E	F	
0	+20	130°	QF	10	14.2	
G1	G2	G3	G4	G5	G6	G7
105	127	152				

4W1270 **Gigant**



Haldex: 79149						
OEM: 09319456						
Supplied With: K1030						
Axle Side:L&R			Other Side: 4W1270			
A	B	C	D	E	F	
0	+20	130°	QF	10	14.2	
G1	G2	G3	G4	G5	G6	G7
105	125	140	155	180	250	

4W1275 **Gigant**



Haldex: 79649						
OEM: 09319035						
Supplied With:						
Axle Side:L&R			Other Side: 4W1275			
A	B	C	D	E	F	
0	+20	110°	AP	10	14.2	
G1	G2	G3	G4	G5	G6	G7
105	120	135	150	165	180	250

4W1280 **Gigant**



Haldex: 79144						
OEM: 09319457						
Supplied With:						
Axle Side:			Other Side: 4W1285			
A	B	C	D	E	F	
-29	0	127°	AP	10	14.2	
G1	G2	G3	G4	G5	G6	G7
152	178					

TRAILER

4W1285

Gigant

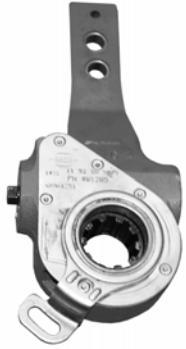

Haldex: 79145						
OEM: 09319458						
Supplied With:						
Axle Side:			Other Side: 4W1280			
A	B	C	D	E	F	
+29	0	127°	AP	10	14.2	
G1	G2	G3	G4	G5	G6	G7
152	178					

4W1300

SAF



Haldex: 79086						
OEM: 4175023700						
Supplied With:						
Axle Side:			Other Side: 4W1305			
A	B	C	D	E	F	
+35	0	144°	AP	10	14.2	
G1	G2	G3	G4	G5	G6	G7
130						

4W1305

SAF



Haldex: 79087						
OEM: 4175023800						
Supplied With:						
Axle Side:			Other Side: 4W1300			
A	B	C	D	E	F	
-35	0	144°	AP	10	14.2	
G1	G2	G3	G4	G5	G6	G7
130						

4W1310

Meritor



Haldex: 79503						
OEM:						
Supplied With:						
Axle Side:			Other Side: 4W1315			
A	B	C	D	E	F	
-25	+30	355°	AP	28	12.9	
G1	G2	G3	G4	G5	G6	G7
127	152					

4W1315

Meritor



Haldex: 79504						
OEM:						
Supplied With:						
Axle Side:			Other Side: 4W1310			
A	B	C	D	E	F	
+25	+30	355°	AP	28	12.9	
G1	G2	G3	G4	G5	G6	G7
127	152					

4W1320

Gigant



Haldex: 79138						
OEM: 09319459						
Supplied With:						
Axle Side:			Other Side: 4W1325			
A	B	C	D	E	F	
+60	+22.5	150°	AP	10	14.2	
G1	G2	G3	G4	G5	G6	G7
152	178	203				

4W1325

Gigant



Haldex: 79139						
OEM: 09319460						
Supplied With:						
Axle Side:			Other Side: 4W1320			
A	B	C	D	E	F	
-60	+22.5	150°	AP	10	14.2	
G1	G2	G3	G4	G5	G6	G7
152	178	203				

4W1330

SAF



Haldex: 79043						
OEM: 4175023500						
Supplied With:						
Axle Side:			Other Side: 4W1335			
A	B	C	D	E	F	
-38	0	144°	AP	10	14.2	
G1	G2	G3	G4	G5	G6	G7
152	178					

TRAILER

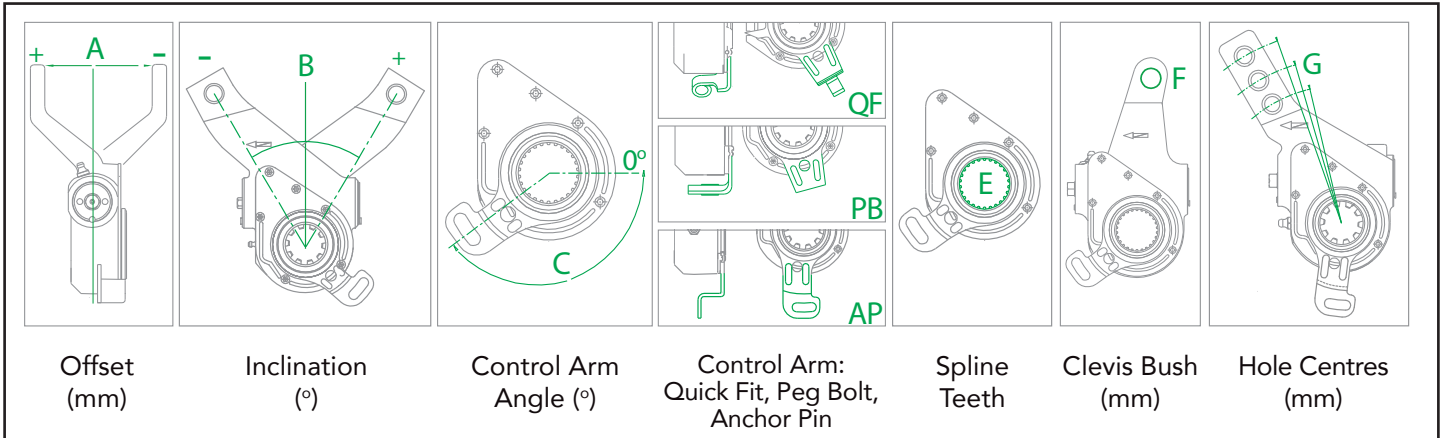

4W1335 SAF



Haldex: 79044						
OEM: 4175023600						
Supplied With:						
Axle Side:			Other Side: 4W1330			
A	B	C	D	E	F	
+38	0	144°	AP	10	14.2	
G1	G2	G3	G4	G5	G6	G7
152	178					

4W1340 SAF



Haldex: 72827						
OEM: 4175023000						
Supplied With:						
Axle Side:L&R			Other Side: 4W1340			
A	B	C	D	E	F	
0	+38	352°	AP	10	14.2	
G1	G2	G3	G4	G5	G6	G7
127	152	178				

6Y1500 BPW



Haldex: 80019						
OEM: 0517482212						
Supplied With: K1030						
Axle Side:L&R			Other Side: 6Y1500			
A	B	C	D	E	F	
0	+20	N/A	QF	10	14.2	
G1	G2	G3	G4	G5	G6	G7
120	135	150	165	180	250	

6Y1505 Meritor



Haldex: 80020						
OEM: 21229249						
Supplied With: K1000						
Axle Side:L&R			Other Side: 6Y1505			
A	B	C	D	E	F	
0	+20	N/A	QF	10	14.2	
G1	G2	G3	G4	G5	G6	G7
115	127	140	153	205		

6Y1510 Fruehauf



Haldex: 80021						
OEM: AJB0743001						
Supplied With: K1020						
Axle Side:L&R			Other Side: 6Y1510			
A	B	C	D	E	F	
0	+20	N/A	QF	37	14.2	
G1	G2	G3	G4	G5	G6	G7
105	127	153	215			

6Y1515 SAF



Haldex: 80022						
OEM: 4175024900						
Supplied With: K1030						
Axle Side:L&R			Other Side: 6Y1515			
A	B	C	D	E	F	
0	+20	N/A	QF	10	14.2	
G1	G2	G3	G4	G5	G6	G7
105	125	140	155	180	250	

TRAILER

6Y1520

SMB



Haldex: 80023						
OEM: MO02416						
Supplied With: K1020						
Axle Side:L&R			Other Side: 6Y1520			
A	B	C	D	E	F	
0	+20	N/A	QF	10	14.2	
G1	G2	G3	G4	G5	G6	G7
105	127	153	215			

6Y1525

Trailer



Haldex: 80024						
OEM: 9002105						
Supplied With: K1020						
Axle Side:L&R			Other Side: 6Y1525			
A	B	C	D	E	F	
0	+20	N/A	QF	10	14.2	
G1	G2	G3	G4	G5	G6	G7
125	150	180	210			

6Y1530

Henred



Haldex: 80037						
OEM:						
Supplied With: K1530						
Axle Side:L&R			Other Side: 6Y1530			
A	B	C	D	E	F	
0	+20	N/A	QF	37	12.9	
G1	G2	G3	G4	G5	G6	G7
125	150					

6Y1535

SAF



Haldex: 80041						
OEM: 4175026200						
Supplied With: K1030						
Axle Side:L&R			Other Side: 6Y1535			
A	B	C	D	E	F	
0	+20	N/A	QF	10	14.2	
G1	G2	G3	G4	G5	G6	G7
125	140	155	180			

6Y1550

Gigant



Haldex: 80108						
OEM: 09319434						
Supplied With: K1030						
Axle Side:L&R			Other Side: 6Y1550			
A	B	C	D	E	F	
0	+20	N/A	QF	10	14.2	
G1	G2	G3	G4	G5	G6	G7
105	120	135	150	165	180	250

6Y1560



Haldex: 80124						
OEM: 09319437						
Supplied With:						
Axle Side:			Other Side: 6Y1565			
A	B	C	D	E	F	
+29	0	N/A	AP	10	14.2	
G1	G2	G3	G4	G5	G6	G7
150	180					

6Y1565



Haldex: 80125						
OEM: 09319438						
Supplied With:						
Axle Side:			Other Side: 6Y1560			
A	B	C	D	E	F	
-29	0	N/A	AP	10	14.2	
G1	G2	G3	G4	G5	G6	G7
150	180					

6Y1570

Gigant



Haldex: 80126						
OEM: 09319439						
Supplied With: K1030						
Axle Side:L&R			Other Side: 6Y1570			
A	B	C	D	E	F	
0	+20	N/A	AP	10	14.2	
G1	G2	G3	G4	G5	G6	G7
105	120	135	150	165	180	

TRAILER

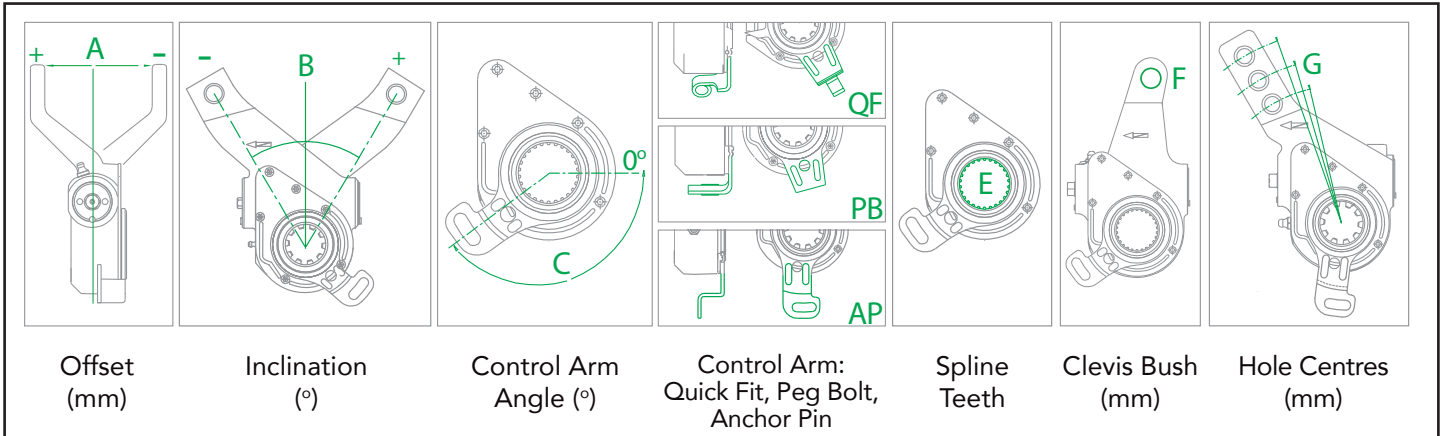

6Y1580		Gigant					
Haldex: 80134							
OEM: 09319440							
Supplied With:							
Axle Side:L&R				Other Side: 6Y1580			
A	B	C	D	E	F		
0	+20	N/A	AP	10	12.9		
G1	G2	G3	G4	G5	G6	G7	
125	150						

6Y1585		Henred					
Haldex: 80032							
OEM:							
Supplied With: K1530							
Axle Side:L&R				Other Side: 6Y1585			
A	B	C	D	E	F		
0	+20	N/A	QF	10	12.9		
G1	G2	G3	G4	G5	G6	G7	
125	150						

6Y1590		SAF					
Haldex: 80292							
OEM: 4175033100							
Supplied With:							
Axle Side:				Other Side: 6Y1595			
A	B	C	D	E	F		
0	+133	N/A	AP	10	14.2		
G1	G2	G3	G4	G5	G6	G7	
127	152	178	200				

6Y1595		SAF					
Haldex: 80293							
OEM: 4175032500							
Supplied With:							
Axle Side:				Other Side: 6Y1590			
A	B	C	D	E	F		
-25	-20	N/A	AP	10	14.2		
G1	G2	G3	G4	G5	G6	G7	
127	140	152					

6Y1600		SAF					
Haldex: 80294							
OEM: 4175032600							
Supplied With:							
Axle Side:L&R				Other Side: 6Y1600			
A	B	C	D	E	F		
+25	-20	N/A	AP	10	14.2		
G1	G2	G3	G4	G5	G6	G7	
127	140	152					

6Y1605		SAF					
Haldex: 80295							
OEM: 4175037400							
Supplied With: K1605							
Axle Side:L&R				Other Side: 6Y1605			
A	B	C	D	E	F		
0	+20	N/A	QF	10	14.2		
G1	G2	G3	G4	G5	G6	G7	
105	127	140	152	178			

TRAILER

6Y1610

SAF

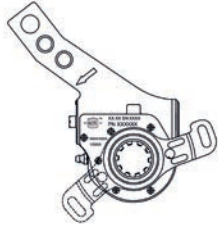

Haldex: 80296						
OEM: 4175032400						
Supplied With:						
Axle Side:L&R			Other Side: 6Y1610			
A	B	C	D	E	F	
0	-38	N/A	AP	10	14.2	
G1	G2	G3	G4	G5	G6	G7
127	152	178				

6Y1615

SAF

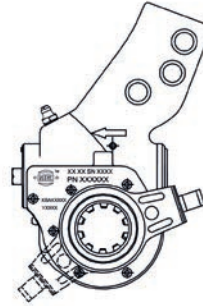

Haldex: 80297						
OEM: 4175032300						
Supplied With: K1605						
Axle Side:L&R			Other Side: 6Y1615			
A	B	C	D	E	F	
0	+20	N/A	QF	10	14.2	
G1	G2	G3	G4	G5	G6	G7
105	127	152				

6Y1620

SAF

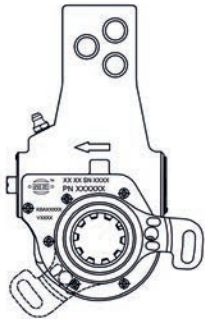

Haldex: 80302						
OEM: 4175032800						
Supplied With:						
Axle Side:			Other Side: 6Y1645			
A	B	C	D	E	F	
-36	0	N/A	AP	10	14.2	
G1	G2	G3	G4	G5	G6	G7
127	140	152				

6Y1625

SAF

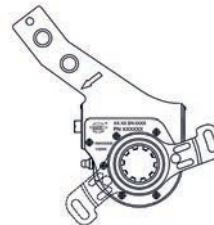

Haldex: 80322						
OEM: 4175031000						
Supplied With:						
Axle Side:L&R			Other Side: 6Y1625			
A	B	C	D	E	F	
0	-38	N/A	AP	10	14.2	
G1	G2	G3	G4	G5	G6	G7
127	165	187				

6Y1630

SAF

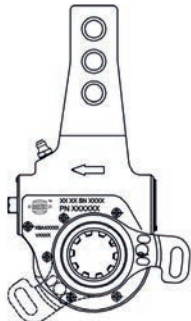

Haldex: 80331						
OEM: 4175033000						
Supplied With:						
Axle Side:			Other Side: 6Y1635			
A	B	C	D	E	F	
-16	0	N/A	AP	10	14.2	
G1	G2	G3	G4	G5	G6	G7
127	152	178				

6Y1635

SAF

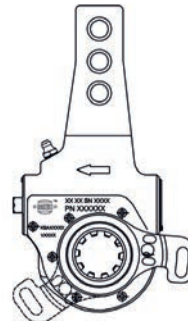

Haldex: 80332						
OEM: 4175032900						
Supplied With:						
Axle Side:			Other Side: 6Y1630			
A	B	C	D	E	F	
+16	0	N/A	AP	10	14.2	
G1	G2	G3	G4	G5	G6	G7
127	152	178				

6Y1640

SAF

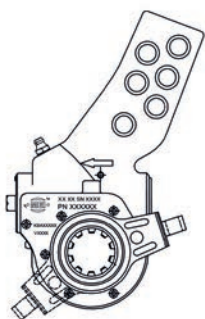

Haldex: 80018						
OEM: 4175037500						
Supplied With: K1605						
Axle Side:L&R			Other Side: 6Y1640			
A	B	C	D	E	F	
0	+20	N/A	QF	10	14.2	
G1	G2	G3	G4	G5	G6	G7
105	127	140	152	165	178	

6Y1645

SAF

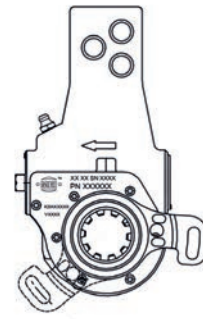

Haldex: 80303						
OEM: 4175032700						
Supplied With:						
Axle Side:			Other Side: 6Y1620			
A	B	C	D	E	F	
+36	0	N/A	AP	10	14.2	
G1	G2	G3	G4	G5	G6	G7
127	140	152				

TRAILER

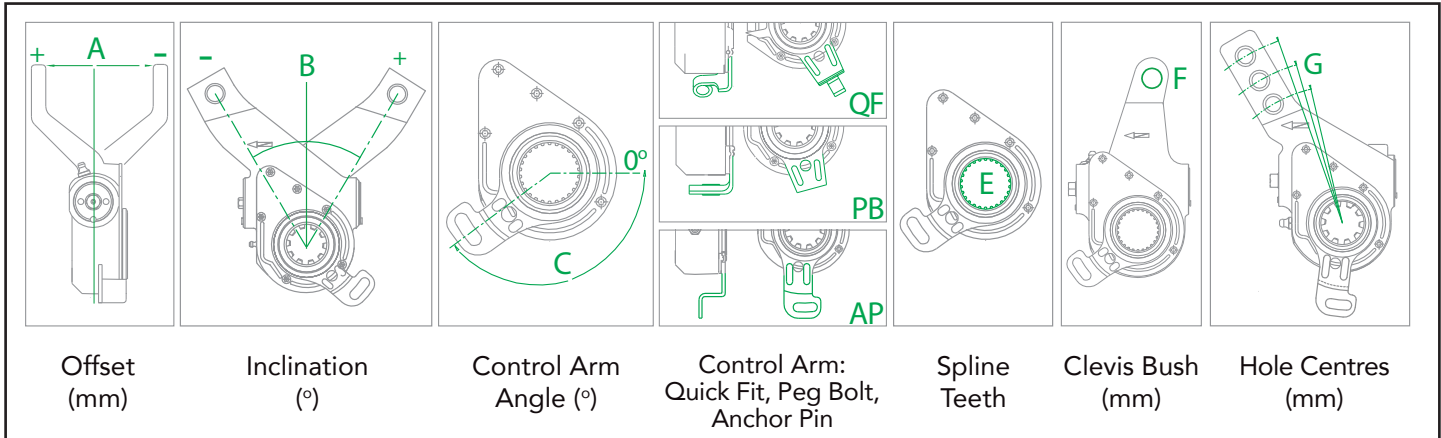

6Y1660 **Verpoort**

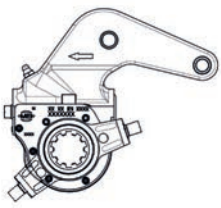

Haldex:						
OEM: GV12790						
Supplied With: K1000						
Axle Side:L&R			Other Side: 6Y1660			
A	B	C	D	E	F	
0	60	N/A	QF	10	12.9	
G1	G2	G3	G4	G5	G6	G7
122	165					

6Y1675 **Gigant**

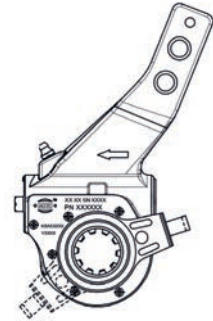

Haldex: 80380						
OEM: 09319468						
Supplied With: K1030						
Axle Side:			Other Side: 6Y1680			
A	B	C	D	E	F	
-60	+22	N/A	QF	10	14.2	
G1	G2	G3	G4	G5	G6	G7
150	180	203				

6Y1680 **Gigant**

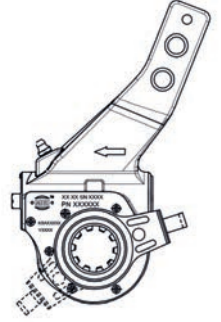

Haldex: 80381						
OEM: 09319467						
Supplied With: K1030						
Axle Side:			Other Side: 6Y1675			
A	B	C	D	E	F	
+60	+22	N/A	QF	10	14.2	
G1	G2	G3	G4	G5	G6	G7
150	180	203				

6Y1685 **Gigant**

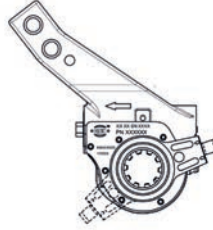

Haldex: 80409						
OEM: 09319446						
Supplied With: K1030						
Axle Side:L&R			Other Side: 6Y1685			
A	B	C	D	E	F	
0	-38	N/A	QF	10	14.2	
G1	G2	G3	G4	G5	G6	G7
130	150	180				

6Y1690 **Gigant**

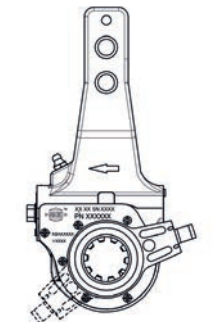

Haldex: 80382						
OEM: 09319441						
Supplied With: K1030						
Axle Side:			Other Side: 6Y1695			
A	B	C	D	E	F	
-29	0	N/A	QF	10	14.2	
G1	G2	G3	G4	G5	G6	G7
150	180	203				

6Y1695 **Gigant**

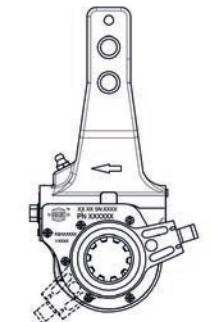

Haldex: 80383						
OEM: 09319442						
Supplied With: K1030						
Axle Side:			Other Side: 6Y1690			
A	B	C	D	E	F	
+29	0	N/A	QF	10	14.2	
G1	G2	G3	G4	G5	G6	G7
150	180	203				

TRAILER

6Y1700

Gigant



Haldex: 80384						
OEM: 09319449						
Supplied With: K1030						
Axle Side:			Other Side: 6Y1705			
A	B	C	D	E	F	
+29	0	N/A	QF	10	14.2	
G1	G2	G3	G4	G5	G6	G7
165	203					

6Y1705

Gigant

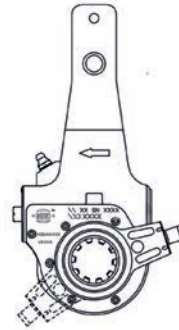

Haldex: 80385						
OEM: 09319448						
Supplied With: K1030						
Axle Side:			Other Side: 6Y1700			
A	B	C	D	E	F	
-29	0	N/A	QF	10	14.2	
G1	G2	G3	G4	G5	G6	G7
165	203					

6Y1710

Gigant

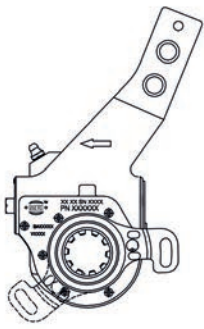

Haldex: 80122						
OEM: 09319447						
Supplied With:						
Axle Side:			Other Side: 6Y1730			
A	B	C	D	E	F	
+60	22	N/A	AP	10	14.2	
G1	G2	G3	G4	G5	G6	G7
150	180	203				

6Y1715

Gigant

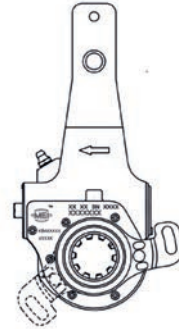

Haldex: 80129						
OEM: 09319444						
Supplied With:						
Axle Side:			Other Side: 6Y1720			
A	B	C	D	E	F	
+29	0	N/A	AP	10	14.2	
G1	G2	G3	G4	G5	G6	G7
165	203					

6Y1720

Gigant

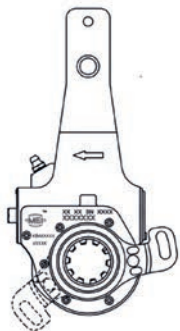

Haldex: 80130						
OEM: 09319445						
Supplied With:						
Axle Side:			Other Side: 6Y1715			
A	B	C	D	E	F	
-29	0	N/A	AP	10	14.2	
G1	G2	G3	G4	G5	G6	G7
165	203					

6Y1725

Gigant

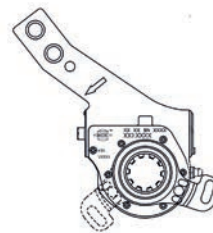

Haldex: 80136						
OEM: 09319443						
Supplied With:						
Axle Side:L&R			Other Side: 6Y1725			
A	B	C	D	E	F	
0	-38	N/A	AP	10	14.2	
G1	G2	G3	G4	G5	G6	G7
130	150	180				

6Y1730

Gigant

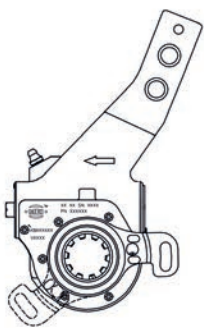

Haldex: 80123						
OEM: 09319450						
Supplied With:						
Axle Side:L&R			Other Side: 6Y1710			
A	B	C	D	E	F	
-60	22	N/A	AP	10	14.2	
G1	G2	G3	G4	G5	G6	G7
150	180	203				

TRAILER

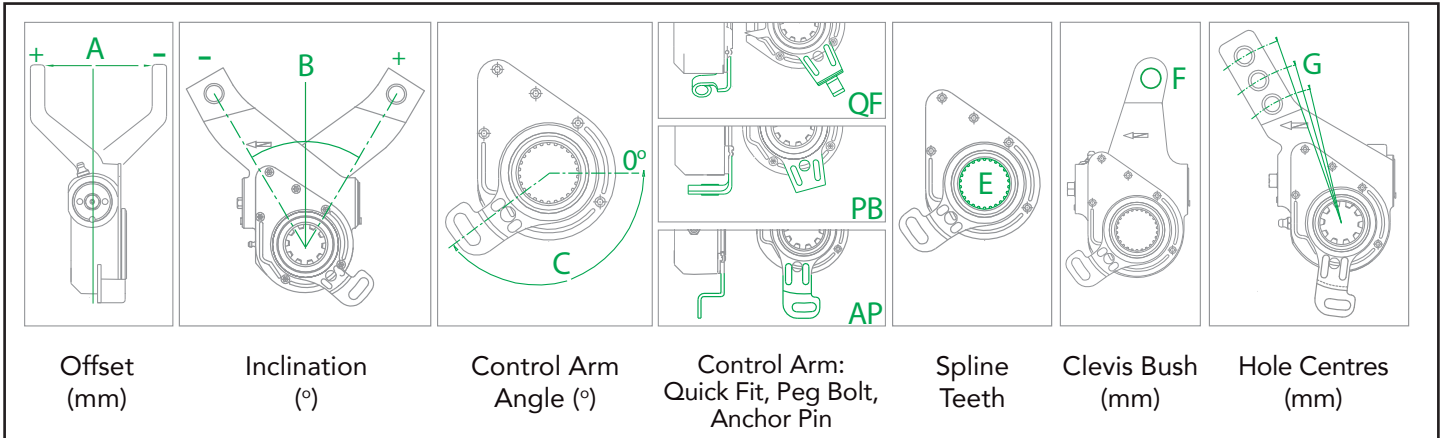

6Y8001 **BPW**



BPW Single: 0517482633						
BPW Pair: 0557482873						
Supplied With: K8000						
Axle Side:L&R			Other Side: 6Y8001			
A	B	C	D	E	F	
0	0	N/A	QF	10	14.2	
G1	G2	G3	G4	G5	G6	G7
120	135	150	165	180	215	250

6Y8011 **BPW**



BPW Single: 0517482213						
BPW Pair: 0557482433						
Supplied With: K8010						
Axle Side:L&R			Other Side: 6Y8011			
A	B	C	D	E	F	
0	0	N/A	QF	10	14.2	
G1	G2	G3	G4	G5	G6	G7
120	135	150	165	180	215	250

6Y8021 **BPW**



BPW Single: 0517482443						
BPW Pair: 0557483083						
Supplied With: K8010						
Axle Side:L&R			Other Side: 6Y8021			
A	B	C	D	E	F	
0	0	N/A	QF	10	14.2	
G1	G2	G3	G4	G5	G6	G7
120	135	150	165	180		

6Y8031 **BPW**



BPW Single: 0517482673						
BPW Pair: 0557483013						
Supplied With: K8000						
Axle Side:L&R			Other Side: 6Y8031			
A	B	C	D	E	F	
0	0	N/A	QF	10	14.2	
G1	G2	G3	G4	G5	G6	G7
120	135	150	165	180		

6Y8041 **BPW**



BPW Single: 0517483043						
BPW Pair: 0557482883						
Supplied With: K8040						
Axle Side:L&R			Other Side: 6Y8041			
A	B	C	D	E	F	
0	0	N/A	QF	10	14.2	
G1	G2	G3	G4	G5	G6	G7
120	135	150	165	180	215	250

6Y8051 **BPW**



BPW Single: 0517483053						
BPW Pair: 0557483073						
Supplied With: K8040						
Axle Side:L&R			Other Side: 6Y8051			
A	B	C	D	E	F	
0	0	N/A	QF	10	14.2	
G1	G2	G3	G4	G5	G6	G7
120	135	150	165	180	215	250

TRAILER

6Y8061

BPW



BPW Single: 0517482473						
BPW Pair: 0557482863						
Supplied With: K8060						
Axle Side:L&R			Other Side: 6Y8061			
A	B	C	D	E	F	
0	0	N/A	QF	10	14.2	
G1	G2	G3	G4	G5	G6	G7
120	135	150	165			

6Y8071

BPW



BPW Single: 0517488513						
BPW Pair: 0557488223						
Supplied With: K8010						
Axle Side:L&R			Other Side: 6Y8071			
A	B	C	D	E	F	
0	+16	N/A	QF	10	14.2	
G1	G2	G3	G4	G5	G6	G7
120	135	150	165	180		

6Y8082

BPW



BPW Single: 0517488953						
BPW Pair: 0557488323						
Supplied With: K8080						
Axle Side:L			Other Side: 6Y8083			
A	B	C	D	E	F	
+21	+12	N/A	QF	10	14.2	
G1	G2	G3	G4	G5	G6	G7
150	165	180	205			

6Y8083

BPW



BPW Single: 0517488963						
BPW Pair: 0557488323						
Supplied With: K8080						
Axle Side:R			Other Side: 6Y8082			
A	B	C	D	E	F	
-21	+12	N/A	QF	10	14.2	
G1	G2	G3	G4	G5	G6	G7
150	165	180	205			

6Y8092

BPW



BPW Single: 0517488683						
BPW Pair: 0557488233						
Supplied With: K8090						
Axle Side:L			Other Side: 6Y8093			
A	B	C	D	E	F	
+9	0	N/A	QF	10	14.2	
G1	G2	G3	G4	G5	G6	G7
150	165	180				

6Y8093

BPW



BPW Single: 0517488693						
BPW Pair: 0557488233						
Supplied With: K8090						
Axle Side:R			Other Side: 6Y8092			
A	B	C	D	E	F	
-9	0	N/A	QF	10	14.2	
G1	G2	G3	G4	G5	G6	G7
150	165	180				

6Y8102

BPW



BPW Single: 0517488703						
BPW Pair: 0557488243						
Supplied With: K8100						
Axle Side:L			Other Side: 6Y8103			
A	B	C	D	E	F	
+34	+43	N/A	QF	10	14.2	
G1	G2	G3	G4	G5	G6	G7
150	165	180	205			

6Y8103

BPW



BPW Single: 0517488713						
BPW Pair: 0557488243						
Supplied With: K8100						
Axle Side:R			Other Side: 6Y8102			
A	B	C	D	E	F	
-34	+43	N/A	QF	10	14.2	
G1	G2	G3	G4	G5	G6	G7
150	165	180	205			

TRUCK AND BUS

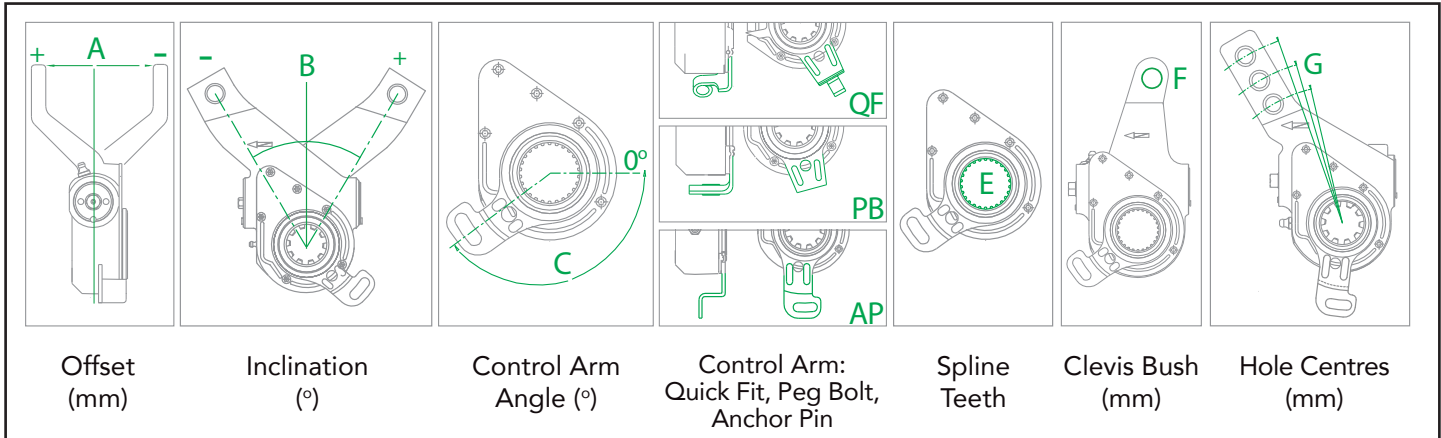

4W2000 **DAF Truck and Bus**



Haldex: 70823						
OEM:						
Supplied With: K0270						
Axle Side:L&R			Other Side: 4W2000			
A	B	C	D	E	F	
0	0	110°	PB	10	14.2	
G1	G2	G3	G4	G5	G6	G7
140						

4W2005 **DAF Truck and Bus**



Haldex: 70871						
OEM:						
Supplied With: K0270						
Axle Side:L&R			Other Side: 4W2005			
A	B	C	D	E	F	
0	-38	30°	PB	10	14.2	
G1	G2	G3	G4	G5	G6	G7
140						

4W2010 **DAF Truck**



Haldex: 72523						
OEM: 0159556						
Supplied With:						
Axle Side:L			Other Side: 4W2015			
A	B	C	D	E	F	
-38	0	155°	AP	10	14.2	
G1	G2	G3	G4	G5	G6	G7
140						

4W2015 **DAF Truck**



Haldex: 72524						
OEM: 0159557						
Supplied With:						
Axle Side:R			Other Side: 4W2010			
A	B	C	D	E	F	
+38	0	155°	AP	10	14.2	
G1	G2	G3	G4	G5	G6	G7
140						

4W2020 **DAF Truck**



Haldex: 72538						
OEM: 0159589						
Supplied With:						
Axle Side:R			Other Side: 4W2025			
A	B	C	D	E	F	
-45	-30	41°	AP	10	14.2	
G1	G2	G3	G4	G5	G6	G7
165						

4W2025 **DAF Truck**



Haldex: 72539						
OEM: 0159590						
Supplied With:						
Axle Side:L			Other Side: 4W2020			
A	B	C	D	E	F	
+45	-30	41°	AP	10	14.2	
G1	G2	G3	G4	G5	G6	G7
165						

TRUCK AND BUS

4W2030 **DAF Truck and Bus**



Haldex: 72534						
OEM: 0537538						
Supplied With:						
Axle Side:L&R			Other Side: 4W2030			
A	B	C	D	E	F	
0	0	339°	AP	10	14.2	
G1	G2	G3	G4	G5	G6	G7
140						

4W2035 **DAF Truck**



Haldex: 72543						
OEM: 0159562						
Supplied With:						
Axle Side:R			Other Side: 4W2105			
A	B	C	D	E	F	
-38	-34	0°	AP	10	14.2	
G1	G2	G3	G4	G5	G6	G7
165						

4W2040 **Mercedes Bus**



Haldex: 72059						
OEM: 3574200538						
Supplied With:						
Axle Side:L&R			Other Side: 4W2040			
A	B	C	D	E	F	
0	+37	0°	AP	26	14.2	
G1	G2	G3	G4	G5	G6	G7
145						

4W2045 **Mercedes Truck and Bus**



Haldex: 70954						
OEM: 6174200238						
Supplied With:						
Axle Side:L&R			Other Side: 4W2045			
A	B	C	D	E	F	
0	+133	84°	AP	26	14.2	
G1	G2	G3	G4	G5	G6	G7
145						

4W2050 **Mercedes Truck**



Haldex: 72594						
OEM: 6524200138						
Supplied With:						
Axle Side:R			Other Side: 4W2055			
A	B	C	D	E	F	
-37	+34	337°	AP	26	14.2	
G1	G2	G3	G4	G5	G6	G7
145						

4W2055 **Mercedes Truck**



Haldex: 72593						
OEM: 6524200038						
Supplied With:						
Axle Side:L			Other Side: 4W2050			
A	B	C	D	E	F	
+37	+34	337°	AP	26	14.2	
G1	G2	G3	G4	G5	G6	G7
146						

4W2060 **Mercedes Truck**



Haldex: 70953						
OEM: 6174200438						
Supplied With:						
Axle Side:R			Other Side: 4W2065			
A	B	C	D	E	F	
+56	+15	106°	AP	26	14.2	
G1	G2	G3	G4	G5	G6	G7
145						

4W2065 **Mercedes Truck**



Haldex: 70952						
OEM: 6174200338						
Supplied With:						
Axle Side:L			Other Side: 4W2060			
A	B	C	D	E	F	
-56	+15	106°	AP	26	14.2	
G1	G2	G3	G4	G5	G6	G7
145						

TRUCK AND BUS

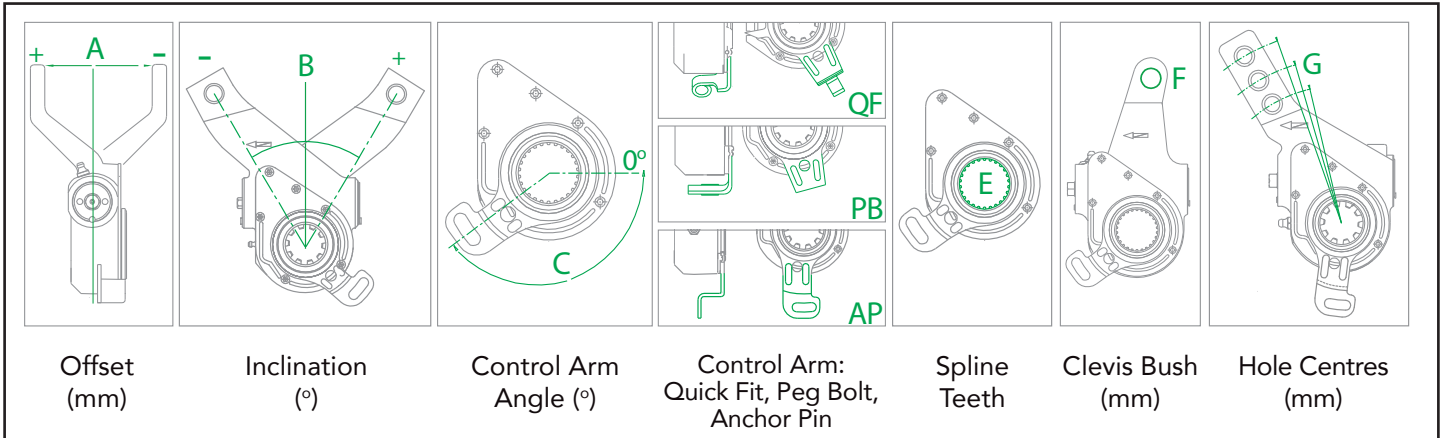

4W2070 **MAN Truck**



Haldex: 79208						
OEM: 81506106211						
Supplied With:						
Axle Side:L			Other Side: 4W2075			
A	B	C	D	E	F	
-56	+4	145°	AP	26	14.2	
G1	G2	G3	G4	G5	G6	G7
145						

4W2075 **MAN Truck**



Haldex: 79209						
OEM: 81506106210						
Supplied With:						
Axle Side:R			Other Side: 4W2070			
A	B	C	D	E	F	
+56	+4	145°	AP	26	14.2	
G1	G2	G3	G4	G5	G6	G7
145						

4W2080 **MAN Truck and Bus**



Haldex: 79212						
OEM: 81506106231						
Supplied With:						
Axle Side:L&R			Other Side: 4W2080			
A	B	C	D	E	F	
0	+133	74°	AP	26	14.2	
G1	G2	G3	G4	G5	G6	G7
145						

4W2085 **Kassbohrer**



Haldex: 72758						
OEM: 8238000835						
Supplied With: K0270						
Axle Side:L&R			Other Side: 4W2085			
A	B	C	D	E	F	
0	+20	110°	PB	37	14.2	
G1	G2	G3	G4	G5	G6	G7
120	135	150	165	180	250	

4W2090 **MAN Truck**



Haldex: 79211						
OEM: 81506106212						
Supplied With:						
Axle Side:R			Other Side: 4W2095			
A	B	C	D	E	F	
-18	+34	337°	AP	26	14.2	
G1	G2	G3	G4	G5	G6	G7
145						

4W2095 **MAN Truck**



Haldex: 79210						
OEM: 81506106213						
Supplied With:						
Axle Side:L			Other Side: 4W2090			
A	B	C	D	E	F	
+18	+34	337°	AP	26	14.2	
G1	G2	G3	G4	G5	G6	G7
145						

TRUCK AND BUS

4W2100 Mercedes Bus



Haldex: 70775						
OEM: 3074200338						
Supplied With:						
Axle Side:L&R			Other Side: 4W2100			
A	B	C	D	E	F	
0	+120	80°	AP	26	14.2	
G1	G2	G3	G4	G5	G6	G7
130						

4W2105 DAF Truck



Haldex: 72542						
OEM: 0159561						
Supplied With:						
Axle Side:L			Other Side: 4W2035			
A	B	C	D	E	F	
+38	-34	0°	AP	10	14.2	
G1	G2	G3	G4	G5	G6	G7
165						

4W2110 DAF Truck and Bus



Haldex: 72536						
OEM: 0159587						
Supplied With:						
Axle Side:L			Other Side: 4W2120			
A	B	C	D	E	F	
+38	-34	0°	AP	10	14.2	
G1	G2	G3	G4	G5	G6	G7
140						

4W2115 DAF Truck and Bus



Haldex: 72525						
OEM: 0159558						
Supplied With:						
Axle Side:L			Other Side: 4W2125			
A	B	C	D	E	F	
-38	0	339°	AP	10	14.2	
G1	G2	G3	G4	G5	G6	G7
140						

4W2120 DAF Truck and Bus



Haldex: 72537						
OEM: 0159588						
Supplied With:						
Axle Side:R			Other Side: 4W2110			
A	B	C	D	E	F	
-38	-34	0°	AP	10	14.2	
G1	G2	G3	G4	G5	G6	G7
140						

4W2125 DAF Truck and Bus



Haldex: 72526						
OEM: 0159559						
Supplied With:						
Axle Side:R			Other Side: 4W2115			
A	B	C	D	E	F	
+38	0	339°	AP	10	14.2	
G1	G2	G3	G4	G5	G6	G7
140						

4W2130 Mercedes Bus



Haldex: 72213						
OEM: 3014201138						
Supplied With:						
Axle Side:L&R			Other Side: 4W2130			
A	B	C	D	E	F	
0	-30	335°	AP	26	14.2	
G1	G2	G3	G4	G5	G6	G7
130						

4W2135 Mercedes Truck



Haldex: 72036						
OEM: 3834200438						
Supplied With:						
Axle Side:R			Other Side: 4W2140			
A	B	C	D	E	F	
+56	-5	9°	AP	26	14.2	
G1	G2	G3	G4	G5	G6	G7
145						

TRUCK AND BUS

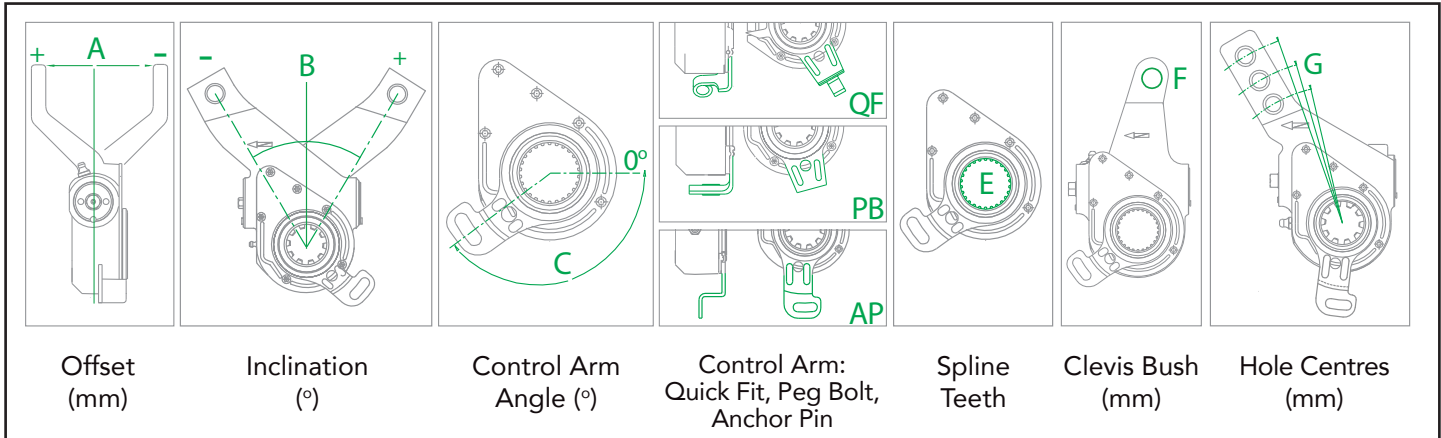

4W2140 Mercedes Truck



Haldex: 72037						
OEM: 3834200538						
Supplied With:						
Axle Side:L			Other Side: 4W2135			
A	B	C	D	E	F	
-56	-5	9°	AP	26	14.2	
G1	G2	G3	G4	G5	G6	G7
145						

4W2145 Mercedes Truck



Haldex: 72063						
OEM: 6194200138						
Supplied With:						
Axle Side:R			Other Side: 4W2165			
A	B	C	D	E	F	
-37	+34	343°	AP	26	14.2	
G1	G2	G3	G4	G5	G6	G7
145						

4W2150 Mercedes Truck



Haldex: 70867						
OEM: 3894200738						
Supplied With:						
Axle Side:L&R			Other Side: 4W2150			
A	B	C	D	E	F	
0	+133	72°	AP	26	14.2	
G1	G2	G3	G4	G5	G6	G7
145						

4W2155 Mercedes Truck



Haldex: 72174						
OEM: 3874200138						
Supplied With:						
Axle Side:R			Other Side: 4W2160			
A	B	C	D	E	F	
+56	+4	145°	AP	26	14.2	
G1	G2	G3	G4	G5	G6	G7
145						

4W2160 Mercedes Truck



Haldex: 72173						
OEM: 3874200038						
Supplied With:						
Axle Side:L			Other Side: 4W2155			
A	B	C	D	E	F	
-56	+4	145°	AP	26	14.2	
G1	G2	G3	G4	G5	G6	G7
143						

4W2165 Mercedes Truck



Haldex: 72062						
OEM: 6194200038						
Supplied With:						
Axle Side:L			Other Side: 4W2145			
A	B	C	D	E	F	
+37	+34	343°	AP	26	14.2	
G1	G2	G3	G4	G5	G6	G7
145						

TRUCK AND BUS

4W2170 Foden Truck



Haldex: 72181						
OEM: 2700021000						
Supplied With:						
Axle Side:L&R			Other Side: 4W2170			
A	B	C	D	E	F	
0	-38	355°	AP	28	12.9	
G1	G2	G3	G4	G5	G6	G7
140						

4W2175 Foden Truck



Haldex: 72199						
OEM: 2700046000						
Supplied With:						
Axle Side:L&R			Other Side: 4W2175			
A	B	C	D	E	F	
0	-38	324°	AP	28	12.9	
G1	G2	G3	G4	G5	G6	G7
127						

4W2180 Leyland Truck



Haldex: 72406						
OEM: ACU8347						
Supplied With:						
Axle Side:L&R			Other Side: 4W2180			
A	B	C	D	E	F	
0	0	80°	AP	10	12.9	
G1	G2	G3	G4	G5	G6	G7
133						

4W2185 Leyland Truck



Haldex: 72403						
OEM: ACU8344						
Supplied With:						
Axle Side:R			Other Side: 4W2190			
A	B	C	D	E	F	
-29	0	309°	AP	10	12.9	
G1	G2	G3	G4	G5	G6	G7
133						

4W2190 Leyland Truck



Haldex: 72404						
OEM: ACU8345						
Supplied With:						
Axle Side:L			Other Side: 4W2185			
A	B	C	D	E	F	
+29	0	309°	AP	10	12.9	
G1	G2	G3	G4	G5	G6	G7
133						

4W2195 Leyland Bus



Haldex: 72422						
OEM: BCU5536						
Supplied With: K0270						
Axle Side:L&R			Other Side: 4W2195			
A	B	C	D	E	F	
0	+26	111°	PB	10	12.9	
G1	G2	G3	G4	G5	G6	G7
165						

4W2200 Leyland Bus



Haldex: 72420						
OEM: BCU5534						
Supplied With: K0270						
Axle Side:L			Other Side: 4W2205			
A	B	C	D	E	F	
+16	+23	120°	PB	10	12.9	
G1	G2	G3	G4	G5	G6	G7
140						

4W2205 Leyland Bus



Haldex: 72421						
OEM: BCU5535						
Supplied With: K0270						
Axle Side:R			Other Side: 4W2200			
A	B	C	D	E	F	
-16	+23	120°	PB	10	12.9	
G1	G2	G3	G4	G5	G6	G7
140						

TRUCK AND BUS

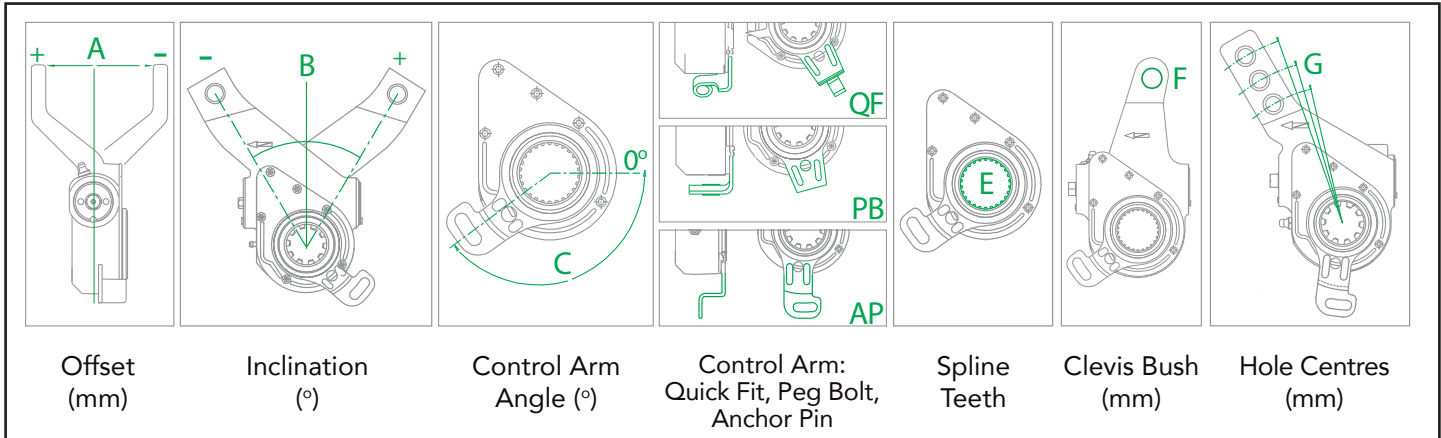

4W2210 Scania Truck and Bus



Haldex: 72664						
OEM: 1112830						
Supplied With:						
Axle Side:R			Other Side: 4W2215			
A	B	C	D	E	F	
-50	0	73°	AP	10	16.2	
G1	G2	G3	G4	G5	G6	G7
165						

4W2215 Scania Truck and Bus



Haldex: 72663						
OEM: 1112829						
Supplied With:						
Axle Side:L			Other Side: 4W2210			
A	B	C	D	E	F	
+50	0	73°	AP	10	16.2	
G1	G2	G3	G4	G5	G6	G7
165						

4W2220 Scania Truck and Bus



Haldex: 72660						
OEM: 1789561						
Supplied With:						
Axle Side:L			Other Side: 4W2260			
A	B	C	D	E	F	
+25	-42	308°	AP	10	16.2	
G1	G2	G3	G4	G5	G6	G7
165						

4W2225 Renault Truck and Bus



Haldex: 79015						
OEM: 5000789894						
Supplied With:						
Axle Side:L			Other Side: 4W2245			
A	B	C	D	E	F	
+38	+30	154°	AP	27	14.2	
G1	G2	G3	G4	G5	G6	G7
175						

4W2230 Renault Truck



Haldex: 79014						
OEM: 5010056686						
Supplied With:						
Axle Side:L			Other Side: 4W2240			
A	B	C	D	E	F	
-38	+30	65°	AP	27	14.2	
G1	G2	G3	G4	G5	G6	G7
175						

4W2235 Foden Truck



Haldex: 72180						
OEM: 2700020000						
Supplied With:						
Axle Side:L&R			Other Side: 4W2235			
A	B	C	D	E	F	
0	-38	355°	AP	28	12.9	
G1	G2	G3	G4	G5	G6	G7
127						

TRUCK AND BUS

4W2240 Renault Truck



Haldex: 79013						
OEM: 5010056685						
Supplied With:						
Axle Side:R			Other Side: 4W2230			
A	B	C	D	E	F	
+38	+30	65°	AP	27	14.2	
G1	G2	G3	G4	G5	G6	G7
175						

4W2245 Renault Truck and Bus



Haldex: 79016						
OEM: 5000789895						
Supplied With:						
Axle Side:R			Other Side: 4W2225			
A	B	C	D	E	F	
-38	+30	154°	AP	27	14.2	
G1	G2	G3	G4	G5	G6	G7
175						

4W2250 Scania Truck and Bus



Haldex: 72662						
OEM: 1789560						
Supplied With:						
Axle Side:L&R			Other Side: 4W2250			
A	B	C	D	E	F	
0	-38	308°	AP	10	16.2	
G1	G2	G3	G4	G5	G6	G7
165						

4W2255 Volvo Bus



Haldex: 72667						
OEM: 1135004						
Supplied With: K0270						
Axle Side:L&R			Other Side: 4W2255			
A	B	C	D	E	F	
0	0	150°	PB	10	12.9	
G1	G2	G3	G4	G5	G6	G7
140						

4W2260 Scania Truck and Bus



Haldex: 72661						
OEM: 1789562						
Supplied With:						
Axle Side:R			Other Side: 4W2220			
A	B	C	D	E	F	
-25	-42	308°	AP	10	16.2	
G1	G2	G3	G4	G5	G6	G7
165						

4W2265 Scania Truck and Bus



Haldex: 72745						
OEM: 218834						
Supplied With: K0270						
Axle Side:R			Other Side: 4W2270			
A	B	C	D	E	F	
-38	-34	305°	PB	10	16.2	
G1	G2	G3	G4	G5	G6	G7
165						

4W2270 Scania Truck and Bus



Haldex: 72744						
OEM: 218833						
Supplied With: K0270						
Axle Side:L			Other Side: 4W2265			
A	B	C	D	E	F	
+38	+34	305°	PB	10	16.2	
G1	G2	G3	G4	G5	G6	G7
165						

4W2275 Volvo Bus



Haldex: 72678						
OEM: 1196321						
Supplied With: K0270						
Axle Side:L&R			Other Side: 4W2275			
A	B	C	D	E	F	
0	0	170°	PB	10	12.9	
G1	G2	G3	G4	G5	G6	G7
140						

TRUCK AND BUS

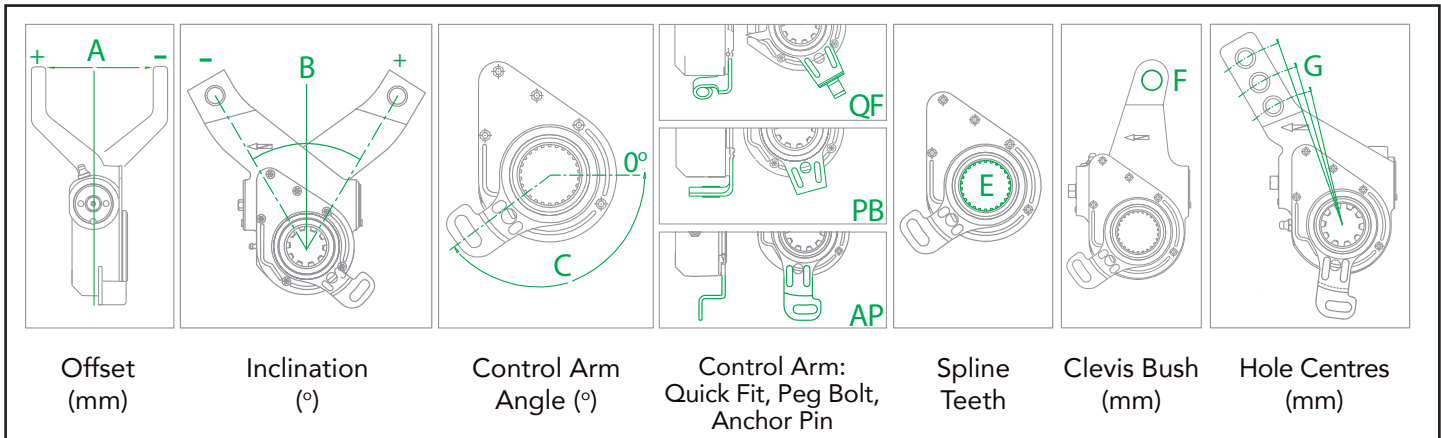

4W2280 **Volvo Bus**



Haldex: 72782						
OEM: 1195461						
Supplied With: K0270						
Axle Side:L			Other Side: 4W2300			
A	B	C	D	E	F	
+15	-24	6°	PB	10	12.9	
G1	G2	G3	G4	G5	G6	G7
145						

4W2285 **Volvo Bus**



Haldex: 72723						
OEM: 1136432						
Supplied With: K0270						
Axle Side:L			Other Side: 4W2290			
A	B	C	D	E	F	
+15	-24	6°	PB	10	12.9	
G1	G2	G3	G4	G5	G6	G7
135						

4W2290 **Volvo Bus**



Haldex: 72724						
OEM: 1136433						
Supplied With: K0270						
Axle Side:R			Other Side: 4W2285			
A	B	C	D	E	F	
-15	-24	6°	PB	10	12.9	
G1	G2	G3	G4	G5	G6	G7
135						

4W2295 **Volvo Bus**



Haldex: 72726						
OEM: 1196322						
Supplied With: K0270						
Axle Side:L&R			Other Side: 4W2295			
A	B	C	D	E	F	
0	0	170°	PB	10	12.9	
G1	G2	G3	G4	G5	G6	G7
152						

4W2300 **Volvo Bus**



Haldex: 72783						
OEM: 1195462						
Supplied With: K0270						
Axle Side:R			Other Side: 4W2280			
A	B	C	D	E	F	
-15	-24	6°	PB	10	12.9	
G1	G2	G3	G4	G5	G6	G7
145						

4W2305 **DAF Truck**



Haldex: 72540						
OEM: 0159591						
Supplied With:						
Axle Side:L&R			Other Side: 4W2305			
A	B	C	D	E	F	
0	-38	338°	AP	10	14.2	
G1	G2	G3	G4	G5	G6	G7
165						

TRUCK AND BUS

4W2310

MCW Bus



Haldex: 70893						
OEM: X1811183						
Supplied With: K0270						
Axle Side:L			Other Side: 4W2700			
A	B	C	D	E	F	
-38	0	75°	PB	10	12.9	
G1	G2	G3	G4	G5	G6	G7
140						

4W2315

Leyland Bus



Haldex: 70945						
OEM: ACU3629						
Supplied With: K0270						
Axle Side:L&R			Other Side: 4W2315			
A	B	C	D	E	F	
0	0	0°	PB	10	12.9	
G1	G2	G3	G4	G5	G6	G7
180						

4W2320

Leyland Bus



Haldex: 70626						
OEM: 10889962						
Supplied With: K0270						
Axle Side:L			Other Side: 4W2435			
A	B	C	D	E	F	
+16	+23	140°	PB	10	12.9	
G1	G2	G3	G4	G5	G6	G7
165						

4W2325

Dennis Bus



Haldex: 70859						
OEM: 611484						
Supplied With: K0270						
Axle Side:L&R			Other Side: 4W2325			
A	B	C	D	E	F	
0	0	75°	PB	10	12.9	
G1	G2	G3	G4	G5	G6	G7
140						

4W2330

Leyland Bus



Haldex: 70624						
OEM: 10901188						
Supplied With: K0270						
Axle Side:L&R			Other Side: 4W2330			
A	B	C	D	E	F	
0	+26	109°	PB	10	12.9	
G1	G2	G3	G4	G5	G6	G7
180						

4W2335

Dennis Bus



Haldex: 72367						
OEM: 651777						
Supplied With: K0270						
Axle Side:L&R			Other Side: 4W2335			
A	B	C	D	E	F	
0	0	15°	PB	10	12.9	
G1	G2	G3	G4	G5	G6	G7
140						

4W2340

Leyland Bus



Haldex: 72441						
OEM: BCU5769						
Supplied With: K0270						
Axle Side:L&R			Other Side: 4W2340			
A	B	C	D	E	F	
0	+26	25°	PB	10	12.9	
G1	G2	G3	G4	G5	G6	G7
165						

4W2345

Leyland Bus



Haldex: 72439						
OEM: BCU5767						
Supplied With: K0270						
Axle Side:L			Other Side: 4W2350			
A	B	C	D	E	F	
+16	+22.5	145°	PB	10	12.9	
G1	G2	G3	G4	G5	G6	G7
155						

TRUCK AND BUS

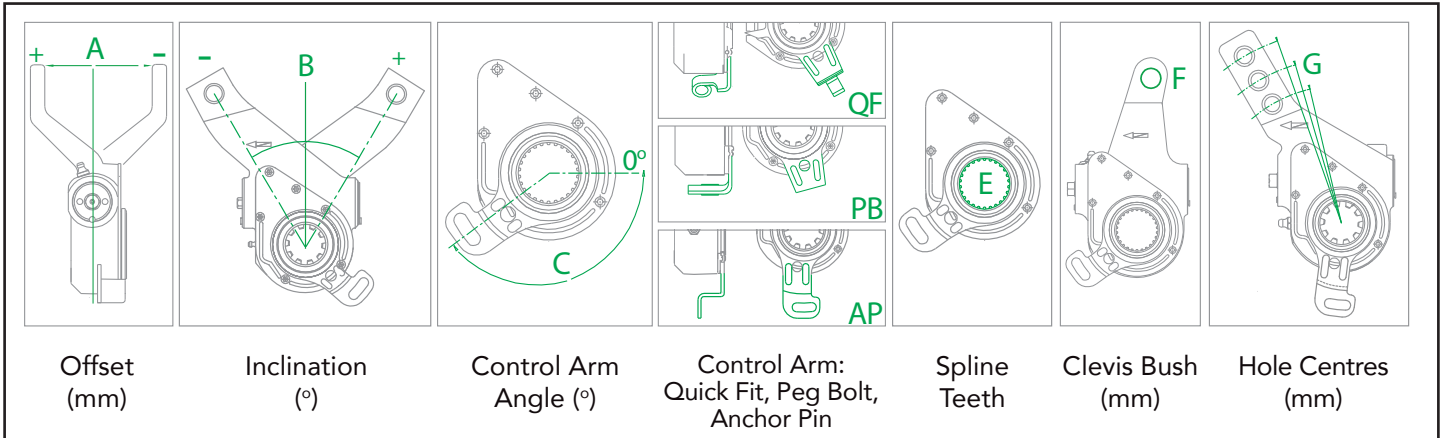

4W2350 **Leyland Bus**



Haldex: 72440						
OEM: BCU5768						
Supplied With: K0270						
Axle Side:R			Other Side: 4W2345			
A	B	C	D	E	F	
-16	+22.5	145°	PB	10	12.9	
G1	G2	G3	G4	G5	G6	G7
155						

4W2355 **Leyland Bus**



Haldex: 70583						
OEM: 10901199						
Supplied With: K0270						
Axle Side:R			Other Side: 4W2390			
A	B	C	D	E	F	
-16	0	110°	PB	10	12.9	
G1	G2	G3	G4	G5	G6	G7
165						

4W2360 **Scania Bus**



Haldex: 72825						
OEM: 1112839						
Supplied With:						
Axle Side:L			Other Side: 4W2595			
A	B	C	D	E	F	
+50	+22	84°	AP	10	16.2	
G1	G2	G3	G4	G5	G6	G7
165						

4W2365 **Leyland Bus**



Haldex: 70512						
OEM: 10907246						
Supplied With: K0270						
Axle Side:R			Other Side: 4W2655			
A	B	C	D	E	F	
+38	0	136°	PB	10	12.9	
G1	G2	G3	G4	G5	G6	G7
180						

4W2370 **Leyland Bus**



Haldex: 70634						
OEM: 10891012						
Supplied With: K0270						
Axle Side:L&R			Other Side: 4W2370			
A	B	C	D	E	F	
0	0	134°	PB	10	12.9	
G1	G2	G3	G4	G5	G6	G7
180						

4W2375 **Dennis Bus**



Haldex: 72364						
OEM: 651623						
Supplied With:						
Axle Side:L&R			Other Side: 4W2375			
A	B	C	D	E	F	
0	0	339°	AP	10	12.9	
G1	G2	G3	G4	G5	G6	G7
127						

TRUCK AND BUS

4W2380 Leyland Truck



Haldex: 72401						
OEM: ACU8342						
Supplied With:						
Axle Side:R			Other Side: 4W2385			
A	B	C	D	E	F	
-29	0	309°	AP	10	12.9	
G1	G2	G3	G4	G5	G6	G7
120						

4W2385 Leyland Truck



Haldex: 72402						
OEM: ACU8343						
Supplied With:						
Axle Side:L			Other Side: 4W2380			
A	B	C	D	E	F	
+29	0	309°	AP	10	12.9	
G1	G2	G3	G4	G5	G6	G7
120						

4W2390 Leyland Bus



Haldex: 70582						
OEM: 10901200						
Supplied With: K0270						
Axle Side:L			Other Side: 4W2355			
A	B	C	D	E	F	
+16	0	110°	PB	10	12.9	
G1	G2	G3	G4	G5	G6	G7
165						

4W2395 DAF Truck and Bus



Haldex: 72548						
OEM: 0159577						
Supplied With:						
Axle Side:L&R			Other Side: 4W2395			
A	B	C	D	E	F	
0	+133	120°	AP	10	14.2	
G1	G2	G3	G4	G5	G6	G7
140						

4W2400 DAF Truck and Bus



Haldex: 72608						
OEM: 0740321						
Supplied With:						
Axle Side:L			Other Side: 4W2425			
A	B	C	D	E	F	
-13	0	338°	AP	10	14.2	
G1	G2	G3	G4	G5	G6	G7
140						

4W2405 Hino Truck



Haldex: 12254						
OEM: 474801790						
Supplied With: K0270						
Axle Side:R			Other Side: 4W2410			
A	B	C	D	E	F	
-38	0	135°	PB	19	12.9	
G1	G2	G3	G4	G5	G6	G7
150						

4W2410 Hino Truck



Haldex: 12255						
OEM: 474901180						
Supplied With: K0270						
Axle Side:L			Other Side: 4W2405			
A	B	C	D	E	F	
+38	0	135°	PB	19	12.9	
G1	G2	G3	G4	G5	G6	G7
150						

4W2415 Hino Truck



Haldex: 12256						
OEM: 474801801						
Supplied With: K0270						
Axle Side:L&R			Other Side: 4W2415			
A	B	C	D	E	F	
0	0	0°	PB	19	12.9	
G1	G2	G3	G4	G5	G6	G7
150						

TRUCK AND BUS

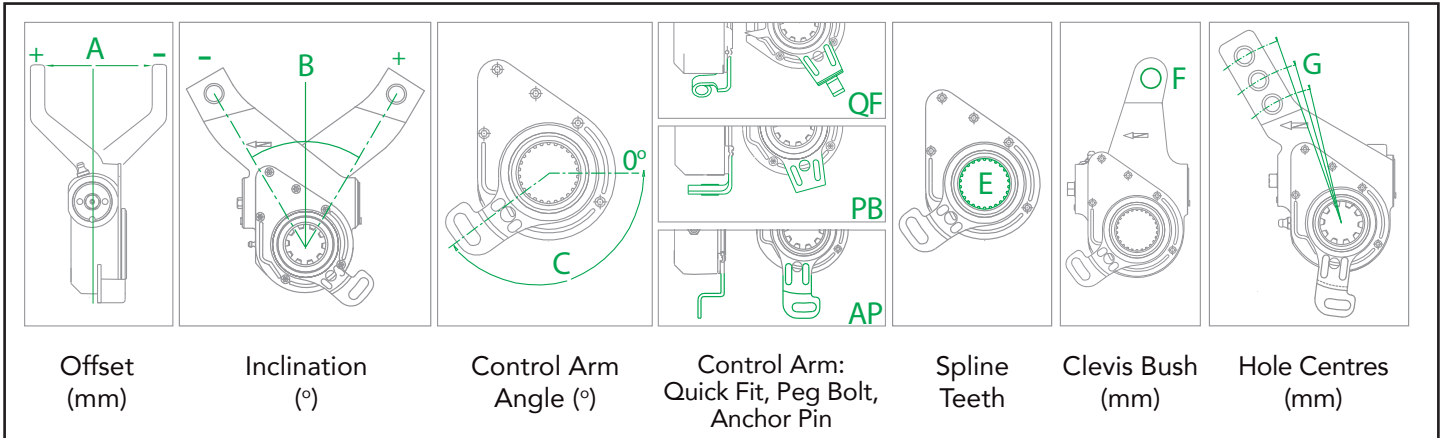

4W2420		Mercedes Truck and Bus					
	Haldex: 72596						
	OEM: 6524200238						
	Supplied With:						
	Axle Side:L&R			Other Side: 4W2420			
A	B	C	D	E	F		
0	+37	130°	AP	26	14.2		
G1	G2	G3	G4	G5	G6	G7	
145							

4W2425		DAF Truck and Bus					
	Haldex: 72609						
	OEM: 0740322						
	Supplied With:						
	Axle Side:R			Other Side: 4W2400			
A	B	C	D	E	F		
+13	0	338°	AP	10	14.2		
G1	G2	G3	G4	G5	G6	G7	
140							

4W2430		Leyland Bus					
	Haldex: 70532						
	OEM: 866101						
	Supplied With: K0270						
	Axle Side:L&R			Other Side: 4W2430			
A	B	C	D	E	F		
0	0	110°	PB	10	12.9		
G1	G2	G3	G4	G5	G6	G7	
203							

4W2435		Leyland Bus					
	Haldex: 70627						
	OEM: 10889963						
	Supplied With: K0270						
	Axle Side:R			Other Side: 4W2320			
A	B	C	D	E	F		
-16	+23	140°	PB	10	12.9		
G1	G2	G3	G4	G5	G6	G7	
165							

4W2440		Mercedes Bus					
	Haldex: 70706						
	OEM: 3054202638						
	Supplied With:						
	Axle Side:L&R			Other Side: 4W2440			
A	B	C	D	E	F		
0	-29	64°	AP	26	14.2		
G1	G2	G3	G4	G5	G6	G7	
115							

4W2445		Mercedes Truck					
	Haldex: 70753						
	OEM: 3894200338						
	Supplied With:						
	Axle Side:R			Other Side: 4W2765			
A	B	C	D	E	F		
+18	+34	343°	AP	26	14.2		
G1	G2	G3	G4	G5	G6	G7	
145							

TRUCK AND BUS

4W2450

Volvo Bus



Haldex: 70832						
OEM: 6863907						
Supplied With: K0270						
Axle Side:R			Other Side: 4W2455			
A	B	C	D	E	F	
-38	-34	305°	PB	10	12.9	
G1	G2	G3	G4	G5	G6	G7
150						

4W2455

Volvo Bus



Haldex: 70833						
OEM: 6863906						
Supplied With: K0270						
Axle Side:L			Other Side: 4W2450			
A	B	C	D	E	F	
+38	+34	305°	PB	10	12.9	
G1	G2	G3	G4	G5	G6	G7
150						

4W2460

Van Hool Bus



Haldex: 70905						
OEM: 633104590						
Supplied With:						
Axle Side:L&R			Other Side: 4W2460			
A	B	C	D	E	F	
0	0	4°	AP	10	14.2	
G1	G2	G3	G4	G5	G6	G7
150						

4W2465

Leyland Bus



Haldex: 70906						
OEM: ABU6924						
Supplied With:						
Axle Side:L&R			Other Side: 4W2465			
A	B	C	D	E	F	
0	0	51°	AP	10	12.9	
G1	G2	G3	G4	G5	G6	G7
140						

4W2470

Mercedes Truck



Haldex: 70918						
OEM: 3854201238						
Supplied With:						
Axle Side:R			Other Side: 4W2840			
A	B	C	D	E	F	
-56	+4	95°	AP	26	14.2	
G1	G2	G3	G4	G5	G6	G7
145						

4W2475

Leyland Bus



Haldex: 70943						
OEM: ACU3627						
Supplied With: K0270						
Axle Side:L			Other Side: 4W2480			
A	B	C	D	E	F	
+16	+23	130°	PB	10	12.9	
G1	G2	G3	G4	G5	G6	G7
155						

4W2480

Leyland Bus



Haldex: 70944						
OEM: ACU3628						
Supplied With: K0270						
Axle Side:R			Other Side: 4W2475			
A	B	C	D	E	F	
-16	+23	130°	PB	10	12.9	
G1	G2	G3	G4	G5	G6	G7
155						

4W2485

Volvo Bus



Haldex: 70977						
OEM: 8398386						
Supplied With: K0270						
Axle Side:L			Other Side: 4W2490			
A	B	C	D	E	F	
-38	0	330°	PB	10	12.9	
G1	G2	G3	G4	G5	G6	G7
152						

TRUCK AND BUS

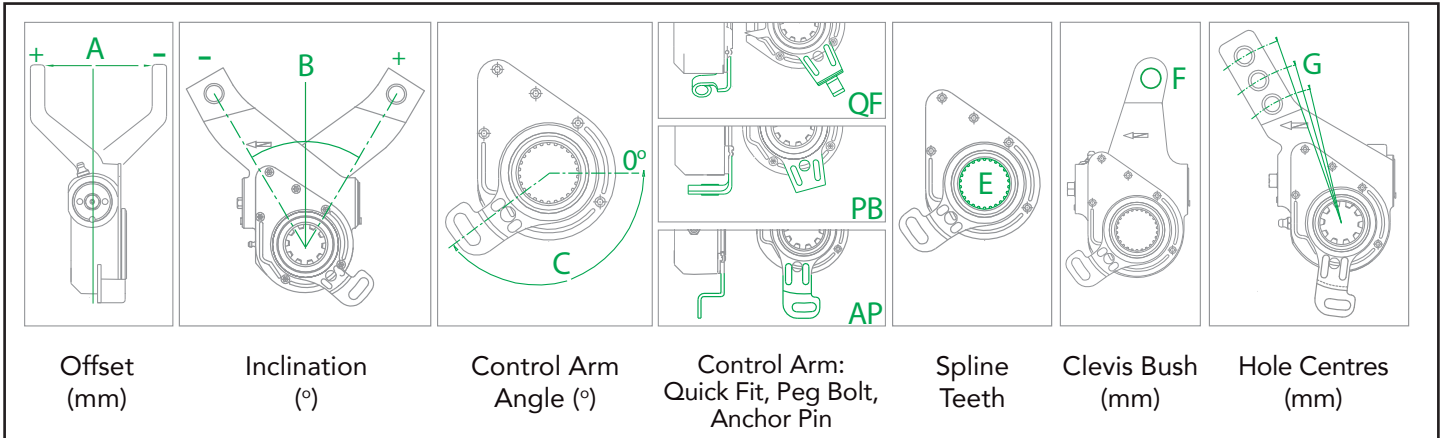

4W2490		Volvo Bus					
	Haldex: 70978						
	OEM: 8398385						
	Supplied With: K0270						
	Axle Side:R			Other Side: 4W2485			
	A	B	C	D	E	F	
+38	0	330°	PB	10	12.9		
G1	G2	G3	G4	G5	G6	G7	
152							

4W2495		Leyland Bus					
	Haldex: 72105						
	OEM: ACU6980						
	Supplied With: K0270						
	Axle Side:L			Other Side: 4W2500			
	A	B	C	D	E	F	
-16	0	85°	PB	10	12.9		
G1	G2	G3	G4	G5	G6	G7	
178							

4W2500		Leyland Bus					
	Haldex: 72106						
	OEM: ACU6981						
	Supplied With: K0270						
	Axle Side:R			Other Side: 4W2495			
	A	B	C	D	E	F	
+16	0	85°	PB	10	12.9		
G1	G2	G3	G4	G5	G6	G7	
178							

4W2505		Neoplan Bus					
	Haldex: 72203						
	OEM: B510643						
	Supplied With:						
	Axle Side:L			Other Side: 4W2510			
	A	B	C	D	E	F	
-25	-30	50°	AP	19	14.2		
G1	G2	G3	G4	G5	G6	G7	
145							

4W2510		Neoplan Bus					
	Haldex: 72204						
	OEM: B510642						
	Supplied With:						
	Axle Side:R			Other Side: 4W2505			
	A	B	C	D	E	F	
+25	-30	50°	AP	19	14.2		
G1	G2	G3	G4	G5	G6	G7	
145							

4W2515		DAF Bus					
	Haldex: 72535						
	OEM: 0159565						
	Supplied With:						
	Axle Side:L&R			Other Side: 4W2515			
	A	B	C	D	E	F	
0	-38	155°	AP	10	14.2		
G1	G2	G3	G4	G5	G6	G7	
140							

TRUCK AND BUS

4W2520

Scania Bus



Haldex: 72665						
OEM: 1112836						
Supplied With:						
Axle Side:R			Other Side: 4W2525			
A	B	C	D	E	F	
-50	0	60°	AP	10	16.2	
G1	G2	G3	G4	G5	G6	G7
165						

4W2525

Scania Bus



Haldex: 72666						
OEM: 1112835						
Supplied With:						
Axle Side:L			Other Side: 4W2520			
A	B	C	D	E	F	
+50	0	60°	AP	10	16.2	
G1	G2	G3	G4	G5	G6	G7
165						

4W2530

Volvo Truck



Haldex: 72668						
OEM: 1586190						
Supplied With: K0270						
Axle Side:L			Other Side: 4W2535			
A	B	C	D	E	F	
+38	-34	0°	PB	10	12.9	
G1	G2	G3	G4	G5	G6	G7
150						

4W2535

Volvo Truck



Haldex: 72669						
OEM: 1586191						
Supplied With: K0270						
Axle Side:R			Other Side: 4W2530			
A	B	C	D	E	F	
-38	-34	0°	PB	10	12.9	
G1	G2	G3	G4	G5	G6	G7
150						

4W2540

Volvo Truck



Haldex: 70923						
OEM: 1586192						
Supplied With: K0270						
Axle Side:R			Other Side: 4W2545			
A	B	C	D	E	F	
+38	-34	0°	PB	10	12.9	
G1	G2	G3	G4	G5	G6	G7
165						

4W2545

Volvo Truck



Haldex: 70924						
OEM: 1586193						
Supplied With: K0270						
Axle Side:L			Other Side: 4W2540			
A	B	C	D	E	F	
-38	-34	0°	PB	10	12.9	
G1	G2	G3	G4	G5	G6	G7
165						

4W2550

Volvo Truck



Haldex: 72673						
OEM: 1592872						
Supplied With: K0270						
Axle Side:R			Other Side: 4W2695			
A	B	C	D	E	F	
-13	0	90°	PB	10	12.9	
G1	G2	G3	G4	G5	G6	G7
140						

4W2555

Volvo Truck



Haldex: 72674						
OEM: 1592873						
Supplied With: K0270						
Axle Side:L			Other Side: 4W2560			
A	B	C	D	E	F	
+22	0	90°	PB	10	12.9	
G1	G2	G3	G4	G5	G6	G7
140						

TRUCK AND BUS

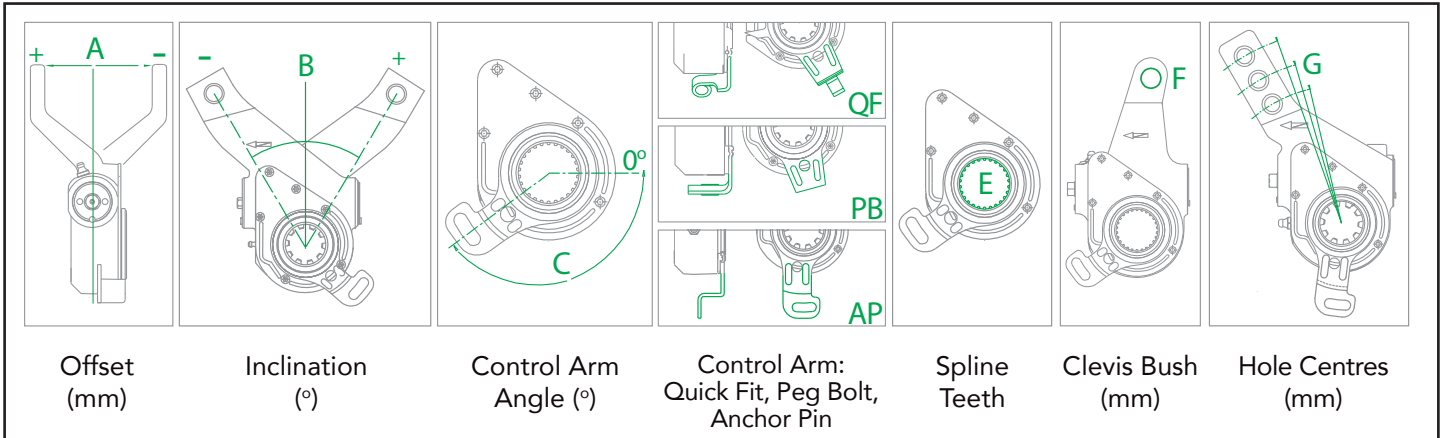

4W2560 **Volvo Truck**



Haldex: 72675						
OEM: 1592874						
Supplied With: K0270						
Axle Side:R			Other Side: 4W2555			
A	B	C	D	E	F	
-22	0	90°	PB	10	12.9	
G1	G2	G3	G4	G5	G6	G7
140						

4W2565 **Volvo Bus**



Haldex: 72715						
OEM: 1134295						
Supplied With: K0270						
Axle Side:L			Other Side: 4W2570			
A	B	C	D	E	F	
-22	0	60°	PB	10	12.9	
G1	G2	G3	G4	G5	G6	G7
133						

4W2570 **Volvo Bus**



Haldex: 72716						
OEM: 1134296						
Supplied With: K0270						
Axle Side:R			Other Side: 4W2565			
A	B	C	D	E	F	
+22	0	60°	PB	10	12.9	
G1	G2	G3	G4	G5	G6	G7
133						

4W2575 **Volvo Bus**



Haldex: 72717						
OEM: 1134293						
Supplied With: K0270						
Axle Side:L			Other Side: 4W2580			
A	B	C	D	E	F	
+13	0	90°	PB	10	12.9	
G1	G2	G3	G4	G5	G6	G7
127						

4W2580 **Volvo Bus**



Haldex: 72718						
OEM: 1134294						
Supplied With: K0270						
Axle Side:R			Other Side: 4W2575			
A	B	C	D	E	F	
-13	0	90°	PB	10	12.9	
G1	G2	G3	G4	G5	G6	G7
127						

4W2585 **Scania Truck and Bus**



Haldex: 72727						
OEM: 1789571						
Supplied With:						
Axle Side:R			Other Side: 4W2590			
A	B	C	D	E	F	
+16	+23	90°	AP	10	16.2	
G1	G2	G3	G4	G5	G6	G7
130						

TRUCK AND BUS

4W2590 **Scania Truck and Bus**



Haldex: 72728						
OEM: 1789572						
Supplied With:						
Axle Side:L			Other Side: 4W2585			
A	B	C	D	E	F	
-16	+23	90°	AP	10	16.2	
G1	G2	G3	G4	G5	G6	G7
130						

4W2595 **Scania Bus**



Haldex: 72826						
OEM: 1112840						
Supplied With:						
Axle Side:R			Other Side: 4W2360			
A	B	C	D	E	F	
-50	+22	84°	AP	10	16.2	
G1	G2	G3	G4	G5	G6	G7
165						

4W2600 **Scania Truck**



Haldex: 72892						
OEM: 394193						
Supplied With:						
Axle Side:L			Other Side: 4W2605			
A	B	C	D	E	F	
+50	0	85°	AP	10	16.2	
G1	G2	G3	G4	G5	G6	G7
130						

4W2605 **Scania Truck**



Haldex: 72893						
OEM: 394194						
Supplied With:						
Axle Side:R			Other Side: 4W2600			
A	B	C	D	E	F	
-50	0	85°	AP	10	16.2	
G1	G2	G3	G4	G5	G6	G7
130						

4W2610 **MAN Truck**



Haldex: 79205						
OEM: 81506106214						
Supplied With:						
Axle Side:R			Other Side: 4W2615			
A	B	C	D	E	F	
+56	+15	100°	AP	26	14.2	
G1	G2	G3	G4	G5	G6	G7
145						

4W2615 **MAN Truck**



Haldex: 79206						
OEM: 81506106215						
Supplied With:						
Axle Side:L			Other Side: 4W2610			
A	B	C	D	E	F	
-56	+15	100°	AP	26	14.2	
G1	G2	G3	G4	G5	G6	G7
145						

4W2620 **MAN Truck and Bus**



Haldex: 79223						
OEM: 81506106220						
Supplied With:						
Axle Side:R			Other Side: 4W2625			
A	B	C	D	E	F	
-45	+10	100°	AP	26	14.2	
G1	G2	G3	G4	G5	G6	G7
215						

4W2625 **MAN Truck and Bus**



Haldex: 79224						
OEM: 81506106221						
Supplied With:						
Axle Side:L			Other Side: 4W2620			
A	B	C	D	E	F	
+45	+10	100°	AP	26	14.2	
G1	G2	G3	G4	G5	G6	G7
215						

TRUCK AND BUS

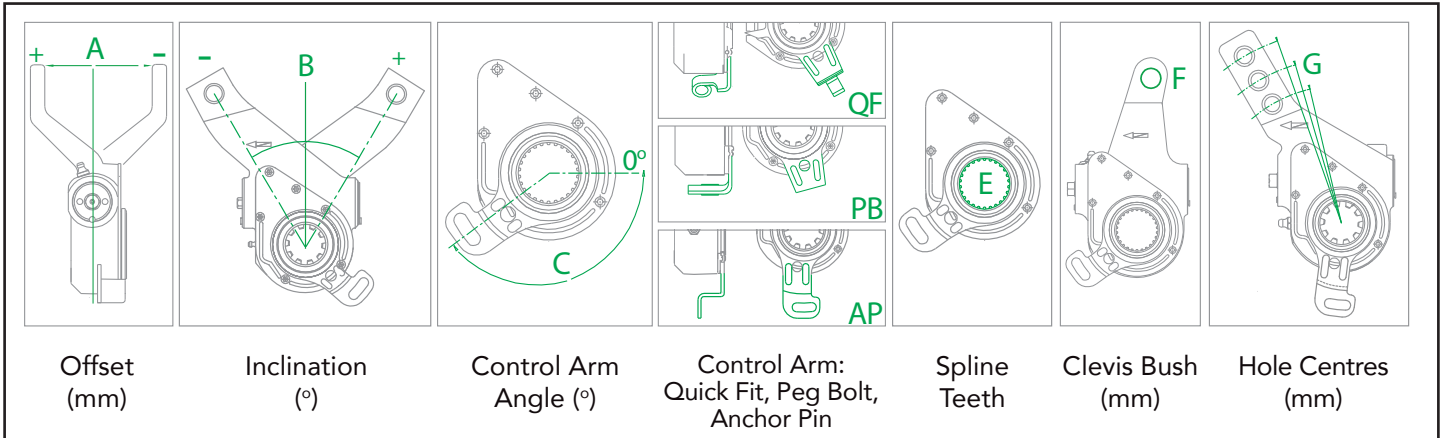

4W2630 Renault Truck



Haldex: 79296						
OEM: 5010098862						
Supplied With:						
Axle Side:L			Other Side: 4W2635			
A	B	C	D	E	F	
-56	+25	105°	AP	27	14.2	
G1	G2	G3	G4	G5	G6	G7
160						

4W2635 Renault Truck



Haldex: 79297						
OEM: 5010098863						
Supplied With:						
Axle Side:R			Other Side: 4W2630			
A	B	C	D	E	F	
+56	+25	105°	AP	27	14.2	
G1	G2	G3	G4	G5	G6	G7
160						

4W2640 Renault Truck

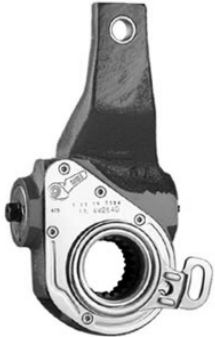

Haldex: 79299						
OEM: 5010216843						
Supplied With:						
Axle Side:L			Other Side: 4W2645			
A	B	C	D	E	F	
-38	0	12°	AP	27	14.2	
G1	G2	G3	G4	G5	G6	G7
160						

4W2645 Renault Truck



Haldex: 79300						
OEM: 5010216844						
Supplied With:						
Axle Side:R			Other Side: 4W2640			
A	B	C	D	E	F	
+38	0	12°	AP	27	14.2	
G1	G2	G3	G4	G5	G6	G7
160						

4W2650 Leyland Bus



Haldex: 70510						
OEM: 10907244						
Supplied With: K0270						
Axle Side:L&R			Other Side: 4W2650			
A	B	C	D	E	F	
0	0	135°	PB	10	12.9	
G1	G2	G3	G4	G5	G6	G7
115						

4W2655 Leyland Bus



Haldex: 70511						
OEM: 10907245						
Supplied With: K0270						
Axle Side:L			Other Side: 4W2365			
A	B	C	D	E	F	
-38	0	136°	PB	10	12.9	
G1	G2	G3	G4	G5	G6	G7
178						

TRUCK AND BUS

4W2660

Volvo Bus



Haldex: 72915						
OEM: 1136430						
Supplied With: K0270						
Axle Side:L			Other Side: 4W2665			
A	B	C	D	E	F	
+13	0	90°	PB	10	12.9	
G1	G2	G3	G4	G5	G6	G7
140						

4W2665

Volvo Bus



Haldex: 72916						
OEM: 1136431						
Supplied With: K0270						
Axle Side:R			Other Side: 4W2660			
A	B	C	D	E	F	
-13	0	90°	PB	10	12.9	
G1	G2	G3	G4	G5	G6	G7
140						

4W2670

Leyland Truck



Haldex: 72407						
OEM: ACU8348						
Supplied With:						
Axle Side:L&R			Other Side: 4W2670			
A	B	C	D	E	F	
0	0	80°	AP	10	12.9	
G1	G2	G3	G4	G5	G6	G7
140						

4W2675

DAF Truck



Haldex: 72541						
OEM: 0159592						
Supplied With:						
Axle Side:L&R			Other Side: 4W2675			
A	B	C	D	E	F	
0	-38	0°	AP	10	14.2	
G1	G2	G3	G4	G5	G6	G7
165						

4W2680

Neoplan Bus



Haldex: 72951						
OEM: 276525						
Supplied With: K0270						
Axle Side:L			Other Side: 4W2850			
A	B	C	D	E	F	
+50	0	73°	PB	10	16.2	
G1	G2	G3	G4	G5	G6	G7
165						

4W2685

Volvo Bus



Haldex: 72906						
OEM: 1135394						
Supplied With: K0270						
Axle Side:L			Other Side: 4W2690			
A	B	C	D	E	F	
+13	0	90°	PB	10	12.9	
G1	G2	G3	G4	G5	G6	G7
140						

4W2690

Volvo Bus



Haldex: 72907						
OEM: 1135395						
Supplied With: K0270						
Axle Side:R			Other Side: 4W2685			
A	B	C	D	E	F	
-13	0	90°	PB	10	12.9	
G1	G2	G3	G4	G5	G6	G7
140						

4W2695

Volvo Truck



Haldex: 72672						
OEM: 1592871						
Supplied With: K0270						
Axle Side:L			Other Side: 4W2550			
A	B	C	D	E	F	
+13	0	90°	PB	10	12.9	
G1	G2	G3	G4	G5	G6	G7
140						

TRUCK AND BUS

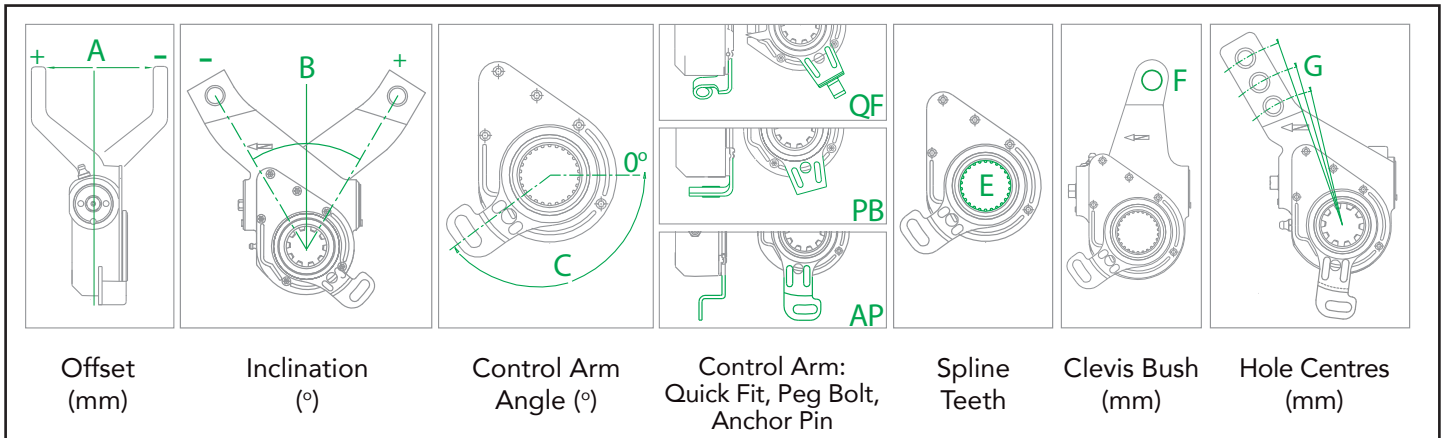

4W2700		MCW Bus					
	Haldex: 70894						
	OEM: X1811184						
	Supplied With: K0270						
	Axle Side:R			Other Side: 4W2310			
	A	B	C	D	E	F	
+38	0	75°	PB	10	12.9		
G1	G2	G3	G4	G5	G6	G7	
140							

4W2705		Volvo Truck					
	Haldex: 72676						
	OEM: 1592876						
	Supplied With: K0270						
	Axle Side:L&R			Other Side: 4W2705			
	A	B	C	D	E	F	
0	0	150°	PB	10	12.9		
G1	G2	G3	G4	G5	G6	G7	
152							

4W2710		Scania Truck and Bus					
	Haldex: 72654						
	OEM: 1112841						
	Supplied With:						
	Axle Side:L&R			Other Side: 4W2710			
	A	B	C	D	E	F	
0	0	308°	AP	10	16.2		
G1	G2	G3	G4	G5	G6	G7	
140	165						

4W2715		Mercedes Bus					
	Haldex: 72211						
	OEM: 3574201138						
	Supplied With:						
	Axle Side:L			Other Side: 4W2720			
	A	B	C	D	E	F	
-15	-14	356°	AP	26	14.2		
G1	G2	G3	G4	G5	G6	G7	
130							

4W2720		Mercedes Bus					
	Haldex: 72212						
	OEM: 3574201238						
	Supplied With:						
	Axle Side:R			Other Side: 4W2715			
	A	B	C	D	E	F	
+15	-14	356°	AP	26	14.2		
G1	G2	G3	G4	G5	G6	G7	
130							

4W2725		DAF Truck					
	Haldex: 72886						
	OEM: 1263485						
	Supplied With:						
	Axle Side:L			Other Side: 4W2730			
	A	B	C	D	E	F	
+60	-10	143°	AP	10	14.2		
G1	G2	G3	G4	G5	G6	G7	
145							

TRUCK AND BUS

4W2730

DAF Truck



Haldex: 72887						
OEM: 1263486						
Supplied With:						
Axle Side:R			Other Side: 4W2725			
A	B	C	D	E	F	
-60	-10	143°	AP	10	14.2	
G1	G2	G3	G4	G5	G6	G7
145						

4W2735

Scania Truck and Bus



Haldex: 79442						
OEM: 1789567						
Supplied With:						
Axle Side:L			Other Side: 4W2740			
A	B	C	D	E	F	
-65	0	85°	AP	10	16.2	
G1	G2	G3	G4	G5	G6	G7
165						

4W2740

Scania Truck and Bus



Haldex: 79443						
OEM: 1789568						
Supplied With:						
Axle Side:R			Other Side: 4W2735			
A	B	C	D	E	F	
+65	0	85°	AP	10	16.2	
G1	G2	G3	G4	G5	G6	G7
165						

4W2745

Iveco Truck



Haldex: 70810						
OEM: 4692759						
Supplied With:						
Axle Side:L&R			Other Side: 4W2745			
A	B	C	D	E	F	
0	0	14°	AP	8	12.9	
G1	G2	G3	G4	G5	G6	G7
160						

4W2750

Mercedes Truck



Haldex: 72038						
OEM: 6234200738						
Supplied With:						
Axle Side:R			Other Side: 4W2755			
A	B	C	D	E	F	
+60	+35	10°	AP	26	14.2	
G1	G2	G3	G4	G5	G6	G7
145						

4W2755

Mercedes Truck



Haldex: 72039						
OEM: 6234200638						
Supplied With:						
Axle Side:L			Other Side: 4W2750			
A	B	C	D	E	F	
-60	+35	10°	AP	26	14.2	
G1	G2	G3	G4	G5	G6	G7
145						

4W2760

DAF Truck



Haldex: 72530						
OEM: 0159560						
Supplied With:						
Axle Side:L&R			Other Side: 4W2760			
A	B	C	D	E	F	
0	-38	338°	AP	10	14.2	
G1	G2	G3	G4	G5	G6	G7
140						

4W2765

Mercedes Truck



Haldex: 70754						
OEM: 3894200438						
Supplied With:						
Axle Side:L			Other Side: 4W2445			
A	B	C	D	E	F	
-18	+34	343°	AP	26	14.2	
G1	G2	G3	G4	G5	G6	G7
145						

TRUCK AND BUS

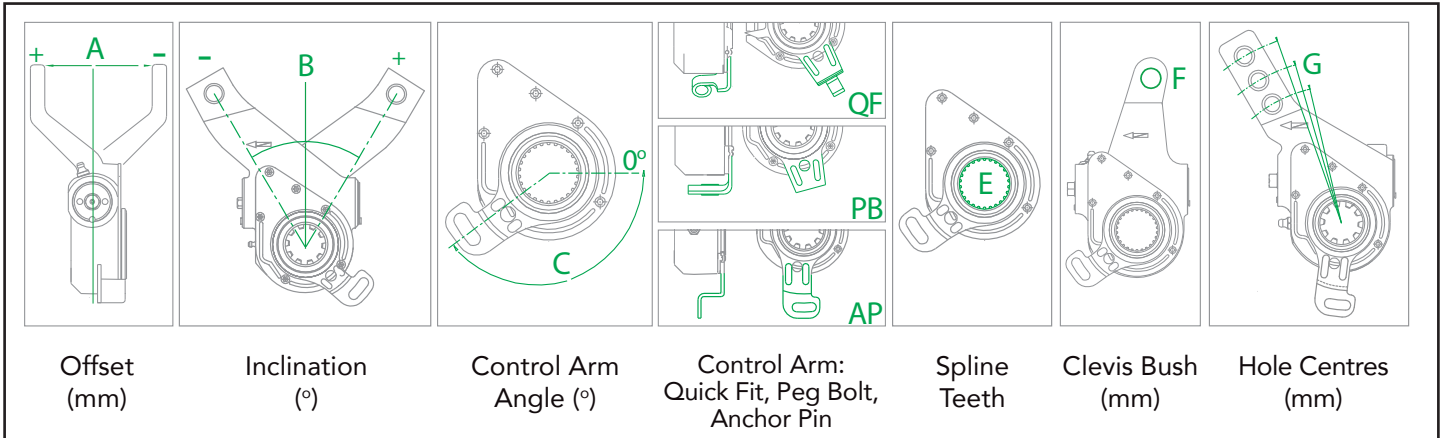

4W2770 **Saurer Truck**



Haldex: 70762						
OEM:						
Supplied With:						
Axle Side:L&R			Other Side: 4W2770			
A	B	C	D	E	F	
0	0	53°	AP	19	14.2	
G1	G2	G3	G4	G5	G6	G7
135	180					

4W2775 **Van Hool Bus**



Haldex: 72459						
OEM: 633104610						
Supplied With:						
Axle Side:L			Other Side: 4W2780			
A	B	C	D	E	F	
-22	0	4°	AP	19	14.2	
G1	G2	G3	G4	G5	G6	G7
160						

4W2780 **Van Hool Bus**



Haldex: 72460						
OEM: 633104620						
Supplied With:						
Axle Side:R			Other Side: 4W2775			
A	B	C	D	E	F	
+22	0	4°	AP	19	14.2	
G1	G2	G3	G4	G5	G6	G7
160						

4W2785 **Liaz Bus**



Haldex: 72688						
OEM: 070276010						
Supplied With:						
Axle Side:			Other Side: 4W2790			
A	B	C	D	E	F	
+56	+15	100°	AP	19	14.2	
G1	G2	G3	G4	G5	G6	G7
145						

4W2790 **Liaz Bus**



Haldex: 72689						
OEM: 070276011						
Supplied With:						
Axle Side:			Other Side: 4W2785			
A	B	C	D	E	F	
-56	+15	100°	AP	19	14.2	
G1	G2	G3	G4	G5	G6	G7
145						

4W2795 **Renault Truck**



Haldex: 79017						
OEM: 5000791212						
Supplied With:						
Axle Side:L			Other Side: 4W2800			
A	B	C	D	E	F	
+38	0	10°	AP	27	14.2	
G1	G2	G3	G4	G5	G6	G7
175						

TRUCK AND BUS

4W2800

Renault Truck



Haldex: 79018						
OEM: 5000791213						
Supplied With:						
Axle Side:R			Other Side: 4W2795			
A	B	C	D	E	F	
-38	0	10°	AP	27	14.2	
G1	G2	G3	G4	G5	G6	G7
175						

4W2805

DAF Truck and Bus



Haldex: 70824						
OEM: 9007271						
Supplied With: K0270						
Axle Side:R			Other Side: 4W2810			
A	B	C	D	E	F	
-38	0	110°	PB	10	14.2	
G1	G2	G3	G4	G5	G6	G7
140						

4W2810

DAF Truck and Bus



Haldex: 70825						
OEM: 9007272						
Supplied With: K0270						
Axle Side:L			Other Side: 4W2805			
A	B	C	D	E	F	
+38	0	110°	PB	10	14.2	
G1	G2	G3	G4	G5	G6	G7
140						

4W2815

Renault Truck and Bus



Haldex: 79007						
OEM: 5000787264						
Supplied With: K0270						
Axle Side:R			Other Side: 4W2820			
A	B	C	D	E	F	
+38	+30	155°	PB	27	14.2	
G1	G2	G3	G4	G5	G6	G7
175						

4W2820

Renault Truck and Bus



Haldex: 79008						
OEM: 5000787265						
Supplied With: K0270						
Axle Side:L			Other Side: 4W2815			
A	B	C	D	E	F	
-38	+30	155°	PB	27	14.2	
G1	G2	G3	G4	G5	G6	G7
175						

4W2825

Dennis Bus



Haldex: 70986						
OEM: 611485						
Supplied With:						
Axle Side:L&R			Other Side: 4W2825			
A	B	C	D	E	F	
0	0	157°	AP	10	12.9	
G1	G2	G3	G4	G5	G6	G7
140						

4W2830

Mercedes Bus



Haldex: 72070						
OEM: 3454200838						
Supplied With:						
Axle Side:			Other Side: 4W2950			
A	B	C	D	E	F	
+56	+4	103°	AP	26	14.2	
G1	G2	G3	G4	G5	G6	G7
145						

4W2835

Leyland Bus



Haldex: 70530						
OEM: 843685						
Supplied With:						
Axle Side:L&R			Other Side: 4W2835			
A	B	C	D	E	F	
0	0	155°	AP	10	12.9	
G1	G2	G3	G4	G5	G6	G7
180						

TRUCK AND BUS

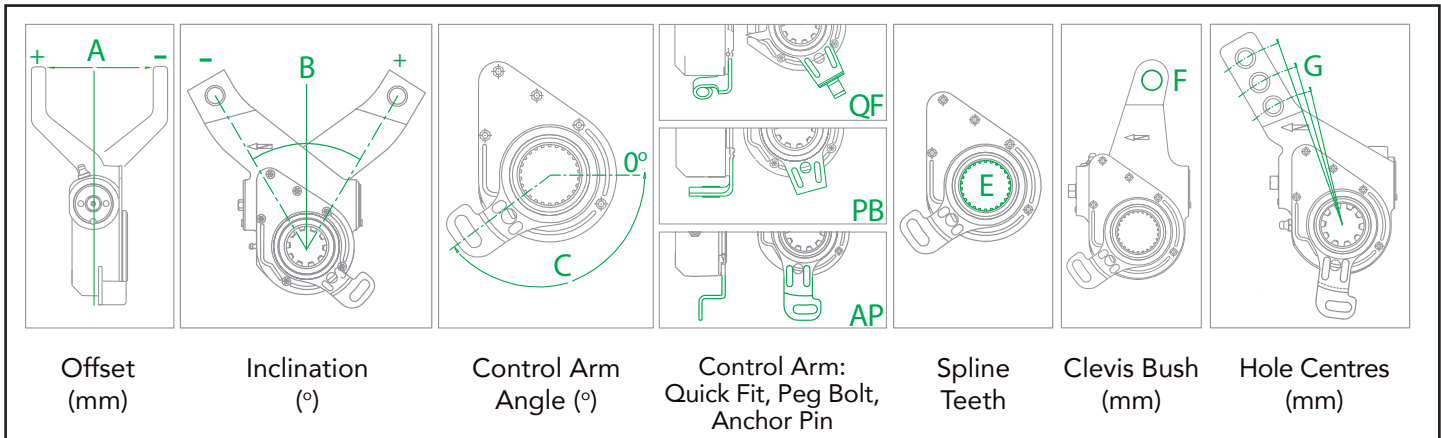

4W2840 Mercedes Truck



Haldex: 70917						
OEM: 3854201138						
Supplied With:						
Axle Side:L			Other Side: 4W2470			
A	B	C	D	E	F	
+56	+4	94°	AP	26	14.2	
G1	G2	G3	G4	G5	G6	G7
145						

4W2845 Neoplan Bus



Haldex: 72177						
OEM: 080250000						
Supplied With:						
Axle Side:L&R			Other Side: 4W2845			
A	B	C	D	E	F	
0	+120	80°	AP	19	14.2	
G1	G2	G3	G4	G5	G6	G7
130						

4W2850 Neoplan Bus

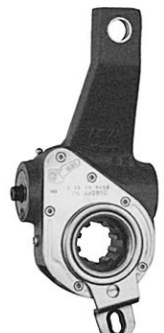

Haldex: 72952						
OEM: 276526						
Supplied With: K0270						
Axle Side:R			Other Side: 4W2680			
A	B	C	D	E	F	
-50	0	73°	PB	10	16.2	
G1	G2	G3	G4	G5	G6	G7
165						

4W2855 Mercedes Truck



Haldex: 72234						
OEM: 6194200238						
Supplied With:						
Axle Side:R			Other Side: 4W2990			
A	B	C	D	E	F	
+37	+34	336°	AP	26	14.2	
G1	G2	G3	G4	G5	G6	G7
145						

4W2860 MAN Bus



Haldex: 72326						
OEM: 633106650						
Supplied With:						
Axle Side:L&R			Other Side: 4W2860			
A	B	C	D	E	F	
0	0	50°	AP	19	14.2	
G1	G2	G3	G4	G5	G6	G7
152						

4W2865 Dennis Bus



Haldex: 72393						
OEM: 651777						
Supplied With: K0270						
Axle Side:L&R			Other Side: 4W2865			
A	B	C	D	E	F	
0	0	76°	PB	10	12.9	
G1	G2	G3	G4	G5	G6	G7
140						

TRUCK AND BUS

4W2870 Renault Truck and Bus



Haldex: 79628						
OEM: 5010067156						
Supplied With:						
Axle Side:			Other Side: 4W2875			
A	B	C	D	E	F	
-56	+25	90°	AP	27	14.2	
G1	G2	G3	G4	G5	G6	G7
175						

4W2875 Renault Truck and Bus



Haldex: 79629						
OEM: 5010067157						
Supplied With:						
Axle Side:			Other Side: 4W2870			
A	B	C	D	E	F	
+56	+25	90°	AP	27	14.2	
G1	G2	G3	G4	G5	G6	G7
175						

4W2880 DAF Truck



Haldex: 72546						
OEM: 0159569						
Supplied With:						
Axle Side:L&R			Other Side: 4W2880			
A	B	C	D	E	F	
0	0	0°	AP	10	16.2	
G1	G2	G3	G4	G5	G6	G7
140						

4W2885 Volvo Truck



Haldex: 72677						
OEM: 1592877						
Supplied With: K0270						
Axle Side:L&R			Other Side: 4W2885			
A	B	C	D	E	F	
0	0	150°	PB	10	12.9	
G1	G2	G3	G4	G5	G6	G7
140						

4W2890 Leyland Bus



Haldex: 70785						
OEM: CAL2240						
Supplied With: K0270						
Axle Side:R			Other Side: 4W2895			
A	B	C	D	E	F	
+13	0	90°	PB	10	12.9	
G1	G2	G3	G4	G5	G6	G7
170						

4W2895 Leyland Bus



Haldex: 70786						
OEM: CAL2241						
Supplied With: K0270						
Axle Side:L			Other Side: 4W2890			
A	B	C	D	E	F	
-13	0	90°	PB	10	12.9	
G1	G2	G3	G4	G5	G6	G7
170						

4W2900 Volvo Bus



Haldex: 72719						
OEM: 1134451						
Supplied With: K0270						
Axle Side:L			Other Side: 4W3210			
A	B	C	D	E	F	
+22	0	110°	PB	10	12.9	
G1	G2	G3	G4	G5	G6	G7
160						

4W2905 Renault Truck



Haldex: 79288						
OEM: 5010098831						
Supplied With:						
Axle Side:R			Other Side: 4W2910			
A	B	C	D	E	F	
+38	0	10°	AP	28	14.2	
G1	G2	G3	G4	G5	G6	G7
160						

TRUCK AND BUS

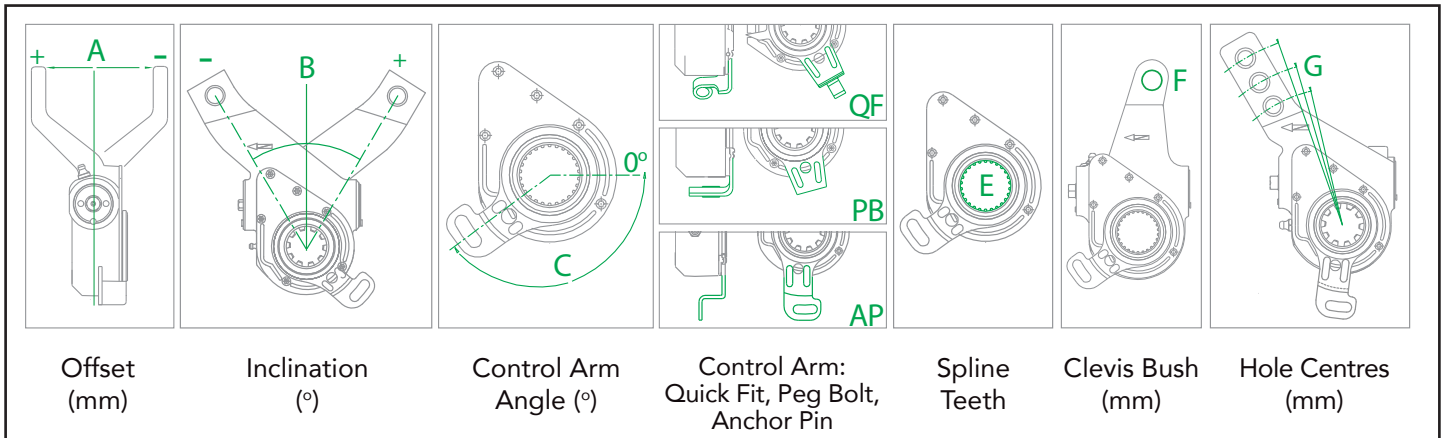

4W2910 Renault Truck



Haldex: 79289						
OEM: 5010098832						
Supplied With:						
Axle Side:L			Other Side: 4W2905			
A	B	C	D	E	F	
-38	0	10°	AP	28	14.2	
G1	G2	G3	G4	G5	G6	G7
160						

4W2915 Pegaso Truck and Bus



Haldex: 72804						
OEM: 914264						
Supplied With:						
Axle Side:L&R			Other Side: 4W2915			
A	B	C	D	E	F	
0	0	25°	AP	19	14.2	
G1	G2	G3	G4	G5	G6	G7
160						

4W2920 Renault Truck



Haldex: 79294						
OEM: 5010098860						
Supplied With:						
Axle Side:R			Other Side: 4W2925			
A	B	C	D	E	F	
-56	+25	35°	AP	27	14.2	
G1	G2	G3	G4	G5	G6	G7
160						

4W2925 Renault Truck



Haldex: 79295						
OEM: 5010098861						
Supplied With:						
Axle Side:L			Other Side: 4W2920			
A	B	C	D	E	F	
+56	+25	35°	AP	27	12.9	
G1	G2	G3	G4	G5	G6	G7
160						

4W2930 Mercedes Bus



Haldex: 72809						
OEM: 3574201338						
Supplied With:						
Axle Side:L			Other Side: 4W3155			
A	B	C	D	E	F	
-18	+34	105°	AP	26	14.2	
G1	G2	G3	G4	G5	G6	G7
130						

4W2935 DAB Bus



Haldex: 72854						
OEM:						
Supplied With:						
Axle Side:L			Other Side: 4W3065			
A	B	C	D	E	F	
+56	-5	10°	AP	19	14.2	
G1	G2	G3	G4	G5	G6	G7
145						

TRUCK AND BUS

4W2940 Renault Truck



Haldex: 79301						
OEM: 5010216904						
Supplied With:						
Axle Side:R			Other Side: 4W2945			
A	B	C	D	E	F	
+38	+30	136°	AP	27	14.2	
G1	G2	G3	G4	G5	G6	G7
160						

4W2945 Renault Truck



Haldex: 79302						
OEM: 5010216905						
Supplied With:						
Axle Side:L			Other Side: 4W2940			
A	B	C	D	E	F	
-38	+30	136°	AP	27	14.2	
G1	G2	G3	G4	G5	G6	G7
160						

4W2950 Mercedes Bus



Haldex: 72069						
OEM: 3454200738						
Supplied With:						
Axle Side:			Other Side: 4W2830			
A	B	C	D	E	F	
-56	+4	103°	AP	26	14.2	
G1	G2	G3	G4	G5	G6	G7
145						

4W2955 Optare Bus



Haldex: 79177						
OEM: L2220055						
Supplied With: K0270						
Axle Side:L&R			Other Side: 4W2955			
A	B	C	D	E	F	
0	-38	30°	PB	28	12.9	
G1	G2	G3	G4	G5	G6	G7
140						

4W2960 Van Hool Bus



Haldex: 72330						
OEM: 3177673						
Supplied With:						
Axle Side:L&R			Other Side: 4W2960			
A	B	C	D	E	F	
0	0	3°	AP	19	14.2	
G1	G2	G3	G4	G5	G6	G7
152						

4W2965 Kassbohrer Bus



Haldex: 70720						
OEM: 82830003040						
Supplied With: K0270						
Axle Side:L&R			Other Side: 4W2965			
A	B	C	D	E	F	
0	0	45°	PB	19	14.2	
G1	G2	G3	G4	G5	G6	G7
145						

4W2970 MCW Bus



Haldex: 70931						
OEM:						
Supplied With: K0270						
Axle Side:R			Other Side: 4W3170			
A	B	C	D	E	F	
+56	+4	75°	PB	10	12.9	
G1	G2	G3	G4	G5	G6	G7
140						

4W2975 Kassbohrer Bus



Haldex: 72592						
OEM: 82850002140						
Supplied With: K0270						
Axle Side:L			Other Side: 4W3575			
A	B	C	D	E	F	
+38	0	145°	PB	19	14.2	
G1	G2	G3	G4	G5	G6	G7
150						

TRUCK AND BUS

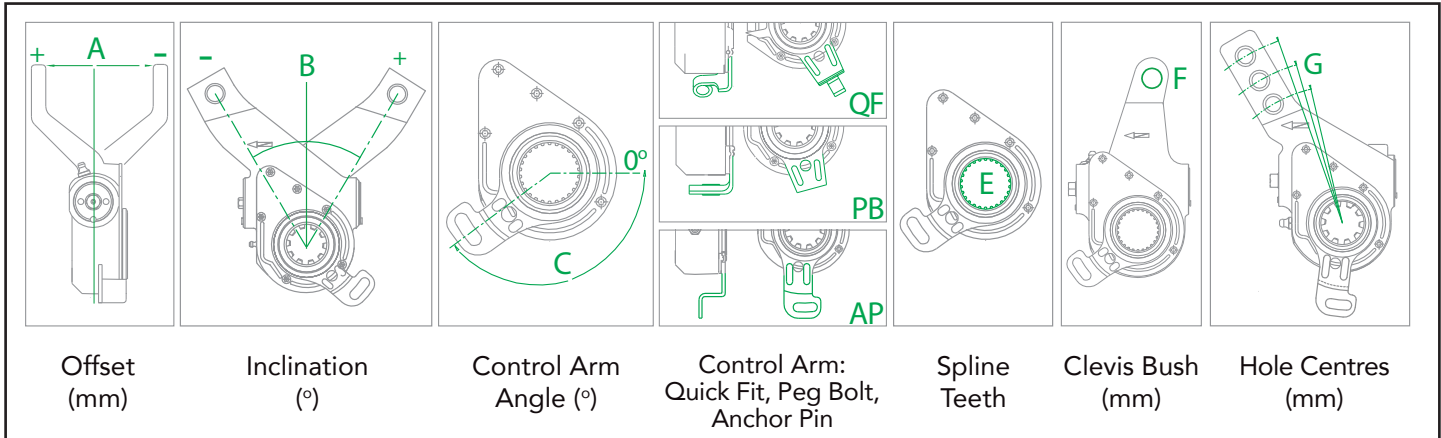

4W2980		Renault Truck					
	Haldex: 79019						
	OEM: 5010037900						
	Supplied With:						
	Axle Side:L&R			Other Side: 4W2980			
	A	B	C	D	E	F	
0	0	352°	AP	27	14.2		
G1	G2	G3	G4	G5	G6	G7	
140							

4W2985		Renault Bus					
	Haldex: 72145						
	OEM: 612051						
	Supplied With: K0270						
	Axle Side:L&R			Other Side: 4W2985			
	A	B	C	D	E	F	
0	0	17°	PB	10	12.9		
G1	G2	G3	G4	G5	G6	G7	
127							

4W2990		Mercedes Truck					
	Haldex: 72235						
	OEM: 6194200338						
	Supplied With:						
	Axle Side:L			Other Side: 4W2855			
	A	B	C	D	E	F	
-37	+34	336°	AP	26	14.2		
G1	G2	G3	G4	G5	G6	G7	
145							

4W2995		MCW Bus					
	Haldex: 72361						
	OEM: 653509						
	Supplied With: K0270						
	Axle Side:L&R			Other Side: 4W2995			
	A	B	C	D	E	F	
0	0	66°	PB	10	12.9		
G1	G2	G3	G4	G5	G6	G7	
115							

4W3000		DAF Bus					
	Haldex: 72816						
	OEM:						
	Supplied With: K0270						
	Axle Side:R			Other Side: 4W3005			
	A	B	C	D	E	F	
+38	0	75°	PB	10	14.2		
G1	G2	G3	G4	G5	G6	G7	
140							

4W3005		DAF Bus					
	Haldex: 72815						
	OEM:						
	Supplied With: K0270						
	Axle Side:L			Other Side: 4W3000			
	A	B	C	D	E	F	
-38	0	75°	PB	10	14.2		
G1	G2	G3	G4	G5	G6	G7	
140							

TRUCK AND BUS

4W3010 **Leyland Truck**



Haldex: 72405						
OEM: ACU8346						
Supplied With:						
Axle Side:L&R			Other Side: 4W3010			
A	B	C	D	E	F	
0	0	80°	AP	10	12.9	
G1	G2	G3	G4	G5	G6	G7
115						

4W3015 **Kassbohrer Bus**



Haldex: 72416						
OEM: 014265271135						
Supplied With: K0270						
Axle Side:L&R			Other Side: 4W3015			
A	B	C	D	E	F	
0	+20	110°	PB	37	14.2	
G1	G2	G3	G4	G5	G6	G7
120	150	180	250			

4W3020 **Ikarus Bus**



Haldex: 72853						
OEM:						
Supplied With: K0270						
Axle Side:L&R			Other Side: 4W3020			
A	B	C	D	E	F	
0	+20	95°	PB	20	14.2	
G1	G2	G3	G4	G5	G6	G7
155	175					

4W3025 **Foden Truck**



Haldex: 72457						
OEM:						
Supplied With: K0270						
Axle Side:L&R			Other Side: 4W3025			
A	B	C	D	E	F	
0	0	75°	PB	10	12.9	
G1	G2	G3	G4	G5	G6	G7
140						

4W3030 **Van Hool Bus**



Haldex: 72462						
OEM: 633104690						
Supplied With:						
Axle Side:R			Other Side: 4W3035			
A	B	C	D	E	F	
+22	0	120°	AP	19	14.2	
G1	G2	G3	G4	G5	G6	G7
150						

4W3035 **Van Hool Bus**



Haldex: 72461						
OEM: 633104700						
Supplied With:						
Axle Side:L			Other Side: 4W3030			
A	B	C	D	E	F	
-22	0	120°	AP	19	14.2	
G1	G2	G3	G4	G5	G6	G7
150						

4W3040 **Renault Truck**



Haldex: 79310						
OEM: 5010260117						
Supplied With:						
Axle Side:R			Other Side: 4W3045			
A	B	C	D	E	F	
-56	+25	144°	AP	27	14.2	
G1	G2	G3	G4	G5	G6	G7
160						

4W3045 **Renault Truck**



Haldex: 79311						
OEM: 5010260118						
Supplied With:						
Axle Side:L			Other Side: 4W3040			
A	B	C	D	E	F	
+56	+25	144°	AP	27	14.2	
G1	G2	G3	G4	G5	G6	G7
160						

TRUCK AND BUS

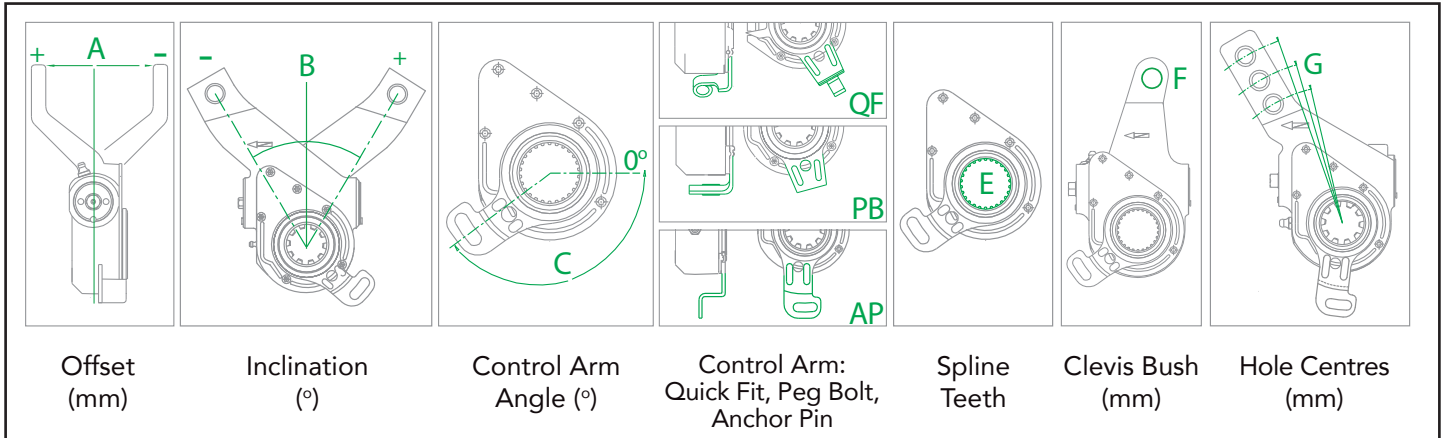

4W3050 Renault Truck



Haldex: 79309						
OEM: 5010260116						
Supplied With:						
Axle Side:R			Other Side: 4W3055			
A	B	C	D	E	F	
+56	+25	144°	AP	27	14.2	
G1	G2	G3	G4	G5	G6	G7
175						

4W3055 Renault Truck



Haldex: 79308						
OEM: 5010260115						
Supplied With:						
Axle Side:L			Other Side: 4W3050			
A	B	C	D	E	F	
-56	+25	144°	AP	27	14.2	
G1	G2	G3	G4	G5	G6	G7
175						

4W3060 Fiat Bus



Haldex: 70891						
OEM:						
Supplied With:						
Axle Side:L&R			Other Side: 4W3060			
A	B	C	D	E	F	
0	0	14°	AP	8	12.9	
G1	G2	G3	G4	G5	G6	G7
170						

4W3065 DAB Bus



Haldex: 72855						
OEM:						
Supplied With:						
Axle Side:R			Other Side: 4W2935			
A	B	C	D	E	F	
-56	-5	10°	AP	19	14.2	
G1	G2	G3	G4	G5	G6	G7
145						

4W3070 DAF Truck



Haldex: 72553						
OEM: 0159578						
Supplied With:						
Axle Side:L&R			Other Side: 4W3070			
A	B	C	D	E	F	
0	0	0°	AP	10	18	
G1	G2	G3	G4	G5	G6	G7
165						

4W3075 Mercedes Truck



Haldex: 72616						
OEM: 6194200638						
Supplied With:						
Axle Side:L			Other Side: 4W3080			
A	B	C	D	E	F	
+56	+15	122°	AP	26	14.2	
G1	G2	G3	G4	G5	G6	G7
145						

TRUCK AND BUS

4W3080 Mercedes Truck



Haldex: 72617						
OEM: 6194200738						
Supplied With:						
Axle Side:R			Other Side: 4W3075			
A	B	C	D	E	F	
-56	+15	122°	AP	26	14.2	
G1	G2	G3	G4	G5	G6	G7
145						

4W3085 Renault Bus



Haldex: 79020						
OEM: 5010013393						
Supplied With:						
Axle Side:L			Other Side: 4W3090			
A	B	C	D	E	F	
+38	+30	90°	AP	27	14.2	
G1	G2	G3	G4	G5	G6	G7
175						

4W3090 Renault Bus



Haldex: 79021						
OEM: 5010013394						
Supplied With:						
Axle Side:R			Other Side: 4W3085			
A	B	C	D	E	F	
-38	+30	90°	AP	27	14.2	
G1	G2	G3	G4	G5	G6	G7
175						

4W3095 Dennis Bus



Haldex: 72362						
OEM: 651626						
Supplied With: K0270						
Axle Side:L&R			Other Side: 4W3095			
A	B	C	D	E	F	
0	0	18°	PB	10	12.9	
G1	G2	G3	G4	G5	G6	G7
127						

4W3100 Foden Truck



Haldex: 72333						
OEM:						
Supplied With: K0270						
Axle Side:L&R			Other Side: 4W3100			
A	B	C	D	E	F	
0	0	17°	PB	10	12.9	
G1	G2	G3	G4	G5	G6	G7
140						

4W3105 Mercedes Truck



Haldex: 72597						
OEM: 6544200038						
Supplied With:						
Axle Side:L			Other Side: 4W3110			
A	B	C	D	E	F	
+50	+34	337°	AP	26	14.2	
G1	G2	G3	G4	G5	G6	G7
145						

4W3110 Mercedes Truck



Haldex: 72598						
OEM: 6544200138						
Supplied With:						
Axle Side:R			Other Side: 4W3105			
A	B	C	D	E	F	
-50	+34	337°	AP	26	14.2	
G1	G2	G3	G4	G5	G6	G7
145						

4W3115 MAN Bus



Haldex: 79225						
OEM: 81506106222						
Supplied With:						
Axle Side:L			Other Side: 4W3120			
A	B	C	D	E	F	
-15	+120	77°	AP	26	14.2	
G1	G2	G3	G4	G5	G6	G7
130						

TRUCK AND BUS

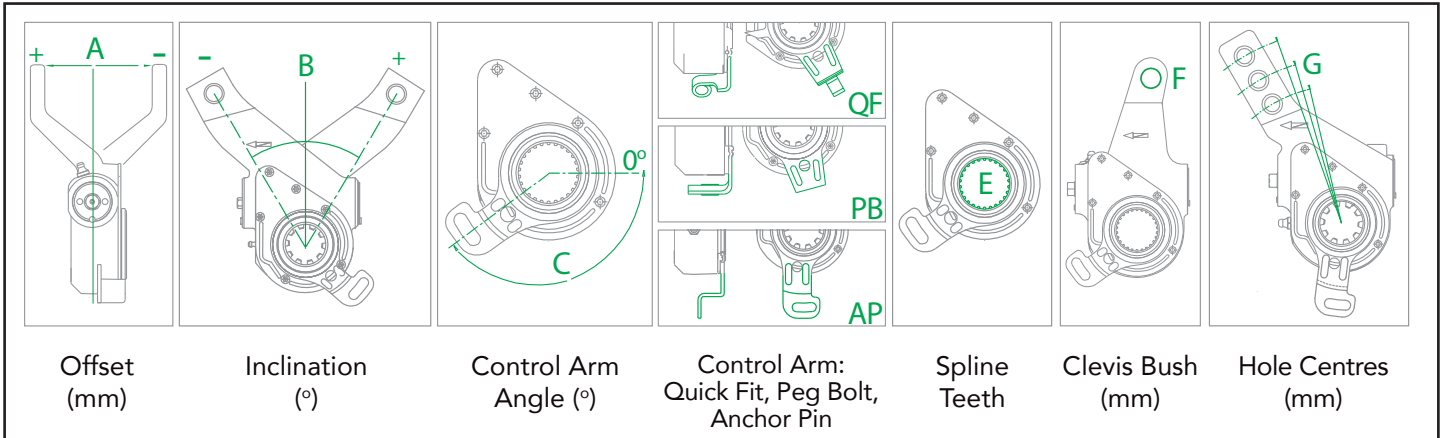

4W3120		MAN Bus					
	Haldex: 79226						
	OEM: 81506106223						
	Supplied With:						
	Axle Side:R			Other Side: 4W3115			
	A	B	C	D	E	F	
+15	+120	77°	AP	26	14.2		
G1	G2	G3	G4	G5	G6	G7	
130							

4W3125		Mercedes Bus					
	Haldex: 70772						
	OEM: 3074200138						
	Supplied With:						
	Axle Side:L			Other Side: 4W3130			
	A	B	C	D	E	F	
-15	-24	345°	AP	26	14.2		
G1	G2	G3	G4	G5	G6	G7	
115							

4W3130		Mercedes Bus					
	Haldex: 70771						
	OEM: 3074200238						
	Supplied With:						
	Axle Side:R			Other Side: 4W3125			
	A	B	C	D	E	F	
+15	-24	345°	AP	26	14.2		
G1	G2	G3	G4	G5	G6	G7	
115							

4W3135		Volvo Bus					
	Haldex: 72785						
	OEM: 1197966						
	Supplied With: K0270						
	Axle Side:R			Other Side: 4W3140			
	A	B	C	D	E	F	
-15	-24	6°	PB	10	12.9		
G1	G2	G3	G4	G5	G6	G7	
165							

4W3140		Volvo Bus					
	Haldex: 72784						
	OEM: 1197965						
	Supplied With: K0270						
	Axle Side:L			Other Side: 4W3135			
	A	B	C	D	E	F	
+15	-24	6°	PB	10	12.9		
G1	G2	G3	G4	G5	G6	G7	
165							

4W3145		Mercedes Truck					
	Haldex: 72040						
	OEM: 3854201738						
	Supplied With:						
	Axle Side:L			Other Side: 4W3150			
	A	B	C	D	E	F	
-42	+105	80°	AP	26	14.2		
G1	G2	G3	G4	G5	G6	G7	
145							

TRUCK AND BUS

4W3150 Mercedes Truck



Haldex: 72041						
OEM: 3854201838						
Supplied With:						
Axle Side:R			Other Side: 4W3145			
A	B	C	D	E	F	
+42	+105	80°	AP	26	14.2	
G1	G2	G3	G4	G5	G6	G7
145						

4W3155 Mercedes Bus



Haldex: 72810						
OEM: 3574201438						
Supplied With:						
Axle Side:R			Other Side: 4W2930			
A	B	C	D	E	F	
+18	+34	105°	AP	26	14.2	
G1	G2	G3	G4	G5	G6	G7
130						

4W3160 Iveco Bus



Haldex: 70809						
OEM: 4695754						
Supplied With:						
Axle Side:L&R			Other Side: 4W3160			
A	B	C	D	E	F	
0	0	45°	AP	8	12.9	
G1	G2	G3	G4	G5	G6	G7
160						

4W3165 MAN Truck



Haldex: 79227						
OEM: 81506106216						
Supplied With:						
Axle Side:L&R			Other Side: 4W3165			
A	B	C	D	E	F	
0	0	115°	AP	26	14.2	
G1	G2	G3	G4	G5	G6	G7
145						

4W3170 MCW Bus



Haldex: 70930						
OEM: X2210967						
Supplied With: K0270						
Axle Side:L			Other Side: 4W2970			
A	B	C	D	E	F	
-56	+4	75°	PB	10	12.9	
G1	G2	G3	G4	G5	G6	G7
140						

4W3175 Dennis Bus



Haldex: 79430						
OEM: 656995-105						
Supplied With:						
Axle Side:R			Other Side: 4W3180			
A	B	C	D	E	F	
+25	-30	50°	AP	19	14.2	
G1	G2	G3	G4	G5	G6	G7
145						

4W3180 Dennis Bus



Haldex: 79429						
OEM: 656995-104						
Supplied With:						
Axle Side:L			Other Side: 4W3175			
A	B	C	D	E	F	
-25	-30	50°	AP	19	14.2	
G1	G2	G3	G4	G5	G6	G7
145						

4W3185 MAN



Haldex: 79197						
OEM: 81506106189						
Supplied With:						
Axle Side:L			Other Side: 4W3190			
A	B	C	D	E	F	
-26	+11	90°	AP	26	14.2	
G1	G2	G3	G4	G5	G6	G7
215						

TRUCK AND BUS

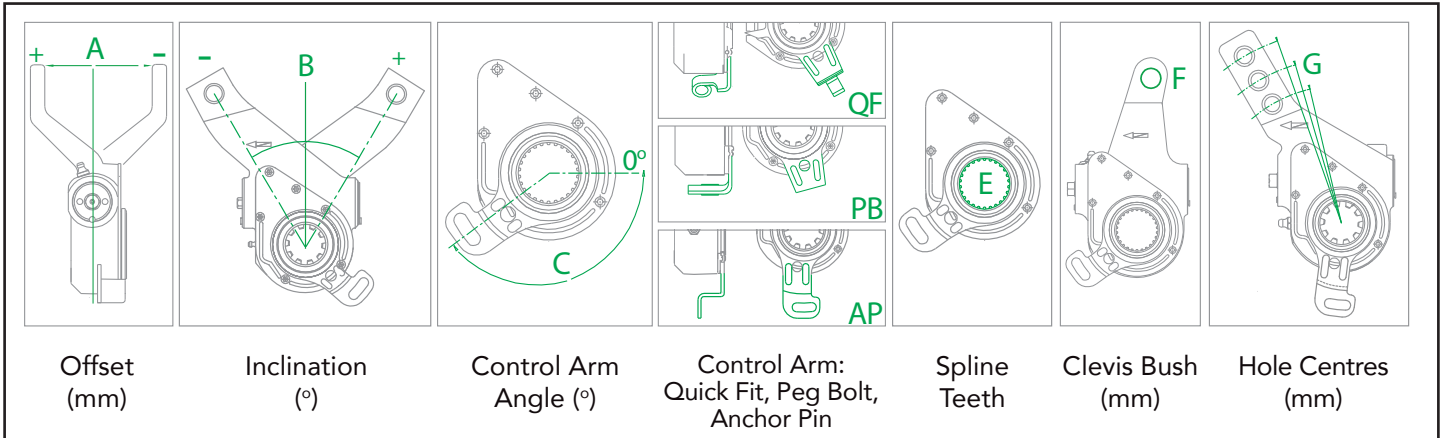

4W3190 **MAN**



Haldex: 79198						
OEM: 81506106190						
Supplied With:						
Axle Side:R			Other Side: 4W3185			
A	B	C	D	E	F	
+26	+11	90°	AP	26	14.2	
G1	G2	G3	G4	G5	G6	G7
215						

4W3195 **Renault Truck and Bus**



Haldex: 79150						
OEM: 5000785205						
Supplied With: K0270						
Axle Side:L			Other Side: 4W3200			
A	B	C	D	E	F	
+23	0	90°	PB	27	14.2	
G1	G2	G3	G4	G5	G6	G7
190						

4W3200 **Renault Truck and Bus**



Haldex: 79151						
OEM: 5000785206						
Supplied With: K0270						
Axle Side:R			Other Side: 4W3195			
A	B	C	D	E	F	
-23	0	90°	PB	27	14.2	
G1	G2	G3	G4	G5	G6	G7
190						

4W3205 **Renault Truck**



Haldex: 79011						
OEM: 5000445830						
Supplied With:						
Axle Side:L&R			Other Side: 4W3205			
A	B	C	D	E	F	
0	0	15°	AP	27	14.2	
G1	G2	G3	G4	G5	G6	G7
150						

4W3210 **Volvo Bus**



Haldex: 72720						
OEM: 1134452						
Supplied With: K0270						
Axle Side:R			Other Side: 4W2900			
A	B	C	D	E	F	
-22	0	110°	PB	10	12.9	
G1	G2	G3	G4	G5	G6	G7
160						

4W3215 **Renault Bus**



Haldex: 79153						
OEM: 5000785204						
Supplied With: K0270						
Axle Side:L			Other Side: 4W3220			
A	B	C	D	E	F	
+22	0	100°	PB	27	14.2	
G1	G2	G3	G4	G5	G6	G7
183						

TRUCK AND BUS

4W3220

Renault Bus



Haldex: 79152						
OEM: 5000785203						
Supplied With: K0270						
Axle Side:L			Other Side: 4W3215			
A	B	C	D	E	F	
-22	0	100°	PB	27	14.2	
G1	G2	G3	G4	G5	G6	G7
183						

4W3225

Van Hool Bus



Haldex: 72646						
OEM: 633106150						
Supplied With:						
Axle Side:			Other Side: 4W3230			
A	B	C	D	E	F	
-29	0	120°	AP	19	14.2	
G1	G2	G3	G4	G5	G6	G7
150						

4W3230

Van Hool Bus



Haldex: 72647						
OEM: 633106140						
Supplied With:						
Axle Side:			Other Side: 4W3225			
A	B	C	D	E	F	
+29	0	120°	AP	19	14.2	
G1	G2	G3	G4	G5	G6	G7
150						

4W3235

Renault Truck



Haldex: 79286						
OEM: 5010145883						
Supplied With:						
Axle Side:L			Other Side: 4W3240			
A	B	C	D	E	F	
+38	+30	65°	AP	27	14.2	
G1	G2	G3	G4	G5	G6	G7
160						

4W3240

Renault Truck



Haldex: 79287						
OEM: 5010145884						
Supplied With:						
Axle Side:R			Other Side: 4W3235			
A	B	C	D	E	F	
-38	+30	65°	AP	27	14.2	
G1	G2	G3	G4	G5	G6	G7
160						

4W3245

Scania Truck



Haldex: 72746						
OEM:						
Supplied With: K0270						
Axle Side:L			Other Side: 4W3250			
A	B	C	D	E	F	
-16	+23	101°	PB	10	12.9	
G1	G2	G3	G4	G5	G6	G7
130						

4W3250

Scania Truck



Haldex: 72747						
OEM:						
Supplied With: K0270						
Axle Side:R			Other Side: 4W3245			
A	B	C	D	E	F	
+16	+23	101°	PB	10	12.9	
G1	G2	G3	G4	G5	G6	G7
130						

4W3255

Kassbohrer Bus



Haldex: 72014						
OEM: 82830005520						
Supplied With: K0270						
Axle Side:L			Other Side: 4W3260			
A	B	C	D	E	F	
-38	0	90°	PB	19	14.2	
G1	G2	G3	G4	G5	G6	G7
160						

TRUCK AND BUS

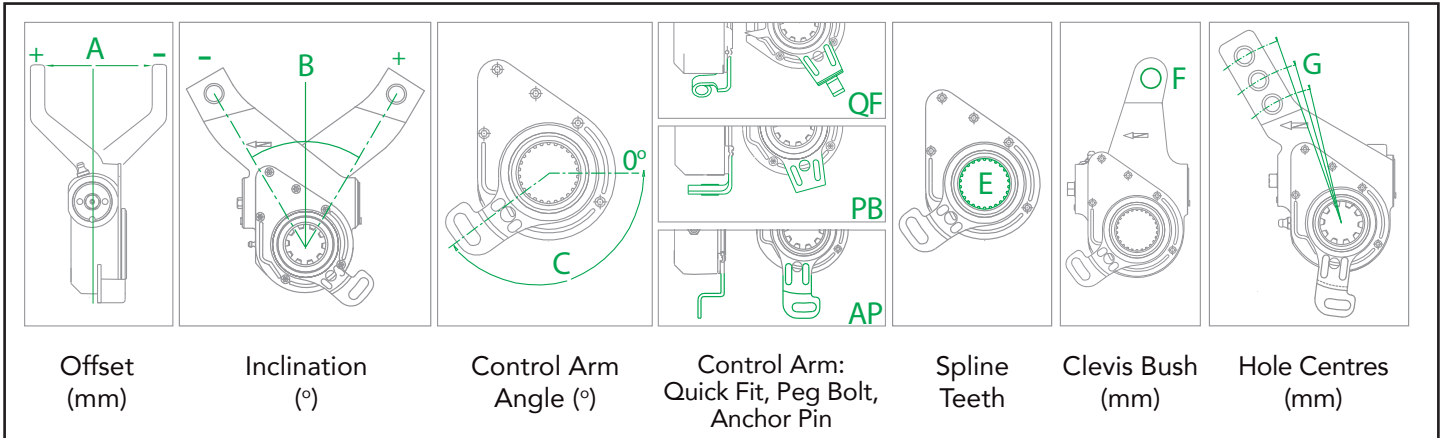

4W3260 **Kassbohrer Bus**



Haldex: 72015						
OEM: 82830005530						
Supplied With: K0270						
Axle Side:R			Other Side: 4W3255			
A	B	C	D	E	F	
+38	0	90°	PB	19	14.2	
G1	G2	G3	G4	G5	G6	G7
160						

4W3265 **MAN Bus**



Haldex: 79216						
OEM: 81506106206						
Supplied With:						
Axle Side:R			Other Side: 4W3270			
A	B	C	D	E	F	
-40	+28	100°	AP	26	14.2	
G1	G2	G3	G4	G5	G6	G7
130						

4W3270 **MAN Bus**



Haldex: 79217						
OEM: 81506106205						
Supplied With:						
Axle Side:L			Other Side: 4W3265			
A	B	C	D	E	F	
+40	+28	100°	AP	26	14.2	
G1	G2	G3	G4	G5	G6	G7
130						

4W3275 **Renault Bus**



Haldex: 79431						
OEM: 5000787230						
Supplied With: K0270						
Axle Side:L			Other Side: 4W3280			
A	B	C	D	E	F	
-45	+10	100°	PB	27	14.2	
G1	G2	G3	G4	G5	G6	G7
270						

4W3280 **Renault Bus**



Haldex: 79432						
OEM: 5000787231						
Supplied With: K0270						
Axle Side:R			Other Side: 4W3275			
A	B	C	D	E	F	
+45	+10	100°	PB	27	14.2	
G1	G2	G3	G4	G5	G6	G7
270						

4W3285 **Mercedes Truck and Bus**



Haldex: 70990						
OEM: 3764200038						
Supplied With:						
Axle Side:R			Other Side: 4W3290			
A	B	C	D	E	F	
-18	+34	115°	AP	26	14.2	
G1	G2	G3	G4	G5	G6	G7
145						

TRUCK AND BUS

4W3290 Mercedes Truck and Bus



Haldex: 70991						
OEM: 3764200138						
Supplied With:						
Axle Side:L			Other Side: 4W3285			
A	B	C	D	E	F	
+18	+34	115°	AP	26	14.2	
G1	G2	G3	G4	G5	G6	G7
145						

4W3295 ZF



Haldex: 72641						
OEM:						
Supplied With:						
Axle Side:L&R			Other Side: 4W3295			
A	B	C	D	E	F	
0	0	2°	AP	19	14.2	
G1	G2	G3	G4	G5	G6	G7
152						

4W3300 Foden Truck



Haldex: 72939						
OEM: 2700040000						
Supplied With: K0270						
Axle Side:L&R			Other Side: 4W3300			
A	B	C	D	E	F	
0	+20	355°	PB	28	12.9	
G1	G2	G3	G4	G5	G6	G7
125						

4W3305 Scania Truck and Bus



Haldex: 72656						
OEM: 219998						
Supplied With: K0270						
Axle Side:R			Other Side: 4W3310			
A	B	C	D	E	F	
-48	+23	78°	PB	10	12.9	
G1	G2	G3	G4	G5	G6	G7
150						

4W3310 Scania Truck and Bus



Haldex: 72655						
OEM: 219997						
Supplied With: K0270						
Axle Side:L			Other Side: 4W3305			
A	B	C	D	E	F	
+48	+23	78°	PB	10	12.9	
G1	G2	G3	G4	G5	G6	G7
150						

4W3315 Scania Bus



Haldex: 72955						
OEM: 321469						
Supplied With: K0270						
Axle Side:L			Other Side: 4W3320			
A	B	C	D	E	F	
+50	0	58°	PB	10	16.2	
G1	G2	G3	G4	G5	G6	G7
165						

4W3320 Scania Bus



Haldex: 72954						
OEM: 321470						
Supplied With: K0270						
Axle Side:R			Other Side: 4W3315			
A	B	C	D	E	F	
-50	0	58°	PB	10	16.2	
G1	G2	G3	G4	G5	G6	G7
165						

4W3325 Dennis Bus



Haldex: 79156						
OEM: 656007-30						
Supplied With:						
Axle Side:R			Other Side: 4W3330			
A	B	C	D	E	F	
-38	0	152°	AP	10	12.9	
G1	G2	G3	G4	G5	G6	G7
165						

TRUCK AND BUS

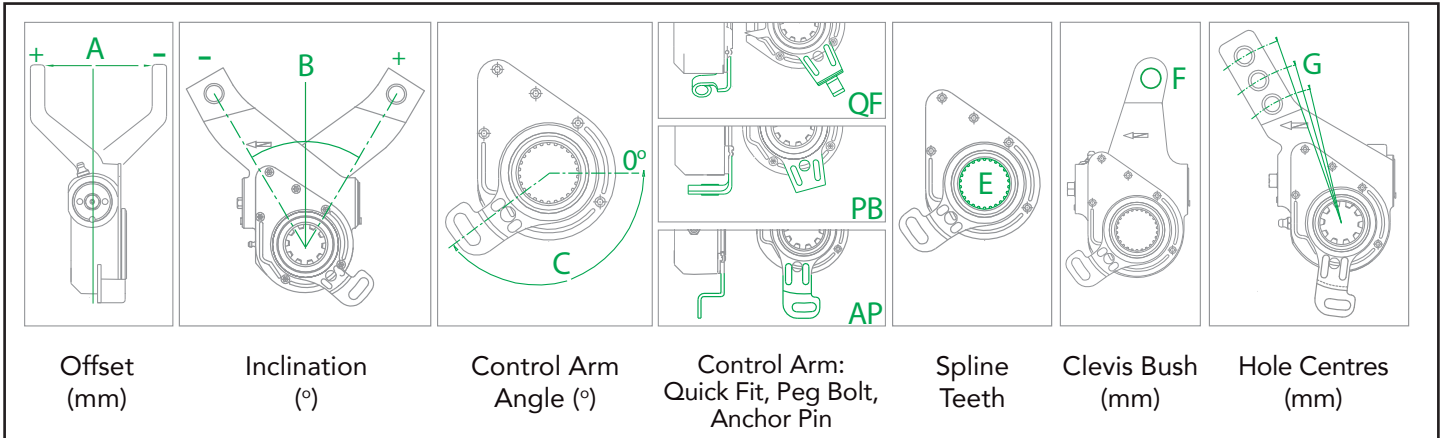

4W3330 **Dennis Bus**



Haldex: 79157						
OEM: 656007-29						
Supplied With:						
Axle Side:L			Other Side: 4W3325			
A	B	C	D	E	F	
+38	0	152°	AP	10	12.9	
G1	G2	G3	G4	G5	G6	G7
165						

4W3335 **MAN Bus**



Haldex: 79220						
OEM: 81506106203						
Supplied With:						
Axle Side:L			Other Side: 4W3340			
A	B	C	D	E	F	
+18	+34	105°	AP	26	14.2	
G1	G2	G3	G4	G5	G6	G7
130						

4W3340 **MAN Bus**



Haldex: 79219						
OEM: 81506106204						
Supplied With:						
Axle Side:R			Other Side: 4W3335			
A	B	C	D	E	F	
-18	+34	105°	AP	26	14.2	
G1	G2	G3	G4	G5	G6	G7
130						

4W3345 **MAN Bus**



Haldex: 79229						
OEM: 81506106229						
Supplied With:						
Axle Side:L			Other Side: 4W3350			
A	B	C	D	E	F	
+18	+34	55°	AP	26	14.2	
G1	G2	G3	G4	G5	G6	G7
130						

4W3350 **MAN Bus**



Haldex: 79228						
OEM: 81506106228						
Supplied With:						
Axle Side:R			Other Side: 4W3345			
A	B	C	D	E	F	
-18	+34	55°	AP	26	14.2	
G1	G2	G3	G4	G5	G6	G7
130						

4W3355 **Pegaso Bus**



Haldex: 72829						
OEM: 915286						
Supplied With:						
Axle Side:R			Other Side: 4W3360			
A	B	C	D	E	F	
-29	0	100°	AP	19	14.2	
G1	G2	G3	G4	G5	G6	G7
180						

TRUCK AND BUS

4W3360

Pegaso Bus



Haldex: 72830						
OEM: 915287						
Supplied With:						
Axle Side:L			Other Side: 4W3355			
A	B	C	D	E	F	
+29	0	100°	AP	19	14.2	
G1	G2	G3	G4	G5	G6	G7
180						

4W3365

Mercedes Bus



Haldex: 79185						
OEM: 3714200038						
Supplied With:						
Axle Side:L&R			Other Side: 4W3365			
A	B	C	D	E	F	
0	+37	114°	AP	26	14.2	
G1	G2	G3	G4	G5	G6	G7
145						

4W3370

MAN



Haldex: 79213						
OEM: 81506106208						
Supplied With:						
Axle Side:R			Other Side: 4W3375			
A	B	C	D	E	F	
+26	0	91°	AP	26	14.2	
G1	G2	G3	G4	G5	G6	G7
145						

4W3375

MAN



Haldex: 79214						
OEM: 81506106207						
Supplied With:						
Axle Side:L			Other Side: 4W3370			
A	B	C	D	E	F	
-26	0	91°	AP	26	14.2	
G1	G2	G3	G4	G5	G6	G7
145						

4W3380

Fiat Bus



Haldex: 70892						
OEM:						
Supplied With:						
Axle Side:L&R			Other Side: 4W3380			
A	B	C	D	E	F	
0	+20	152°	AP	8	12.9	
G1	G2	G3	G4	G5	G6	G7
180						

4W3385

Sicca Bus



Haldex: 70919						
OEM: 5001048						
Supplied With:						
Axle Side:L&R			Other Side: 4W3385			
A	B	C	D	E	F	
0	0	91°	AP	8	12.9	
G1	G2	G3	G4	G5	G6	G7
180						

4W3390

Leyland Bus



Haldex: 70987						
OEM: ACU4866						
Supplied With: K0270						
Axle Side:R			Other Side: 4W3395			
A	B	C	D	E	F	
-38	0	134°	PB	10	12.9	
G1	G2	G3	G4	G5	G6	G7
152						

4W3395

Leyland Bus



Haldex: 70988						
OEM: ACU4867						
Supplied With: K0270						
Axle Side:L			Other Side: 4W3390			
A	B	C	D	E	F	
+38	0	134°	PB	10	12.9	
G1	G2	G3	G4	G5	G6	G7
152						

TRUCK AND BUS

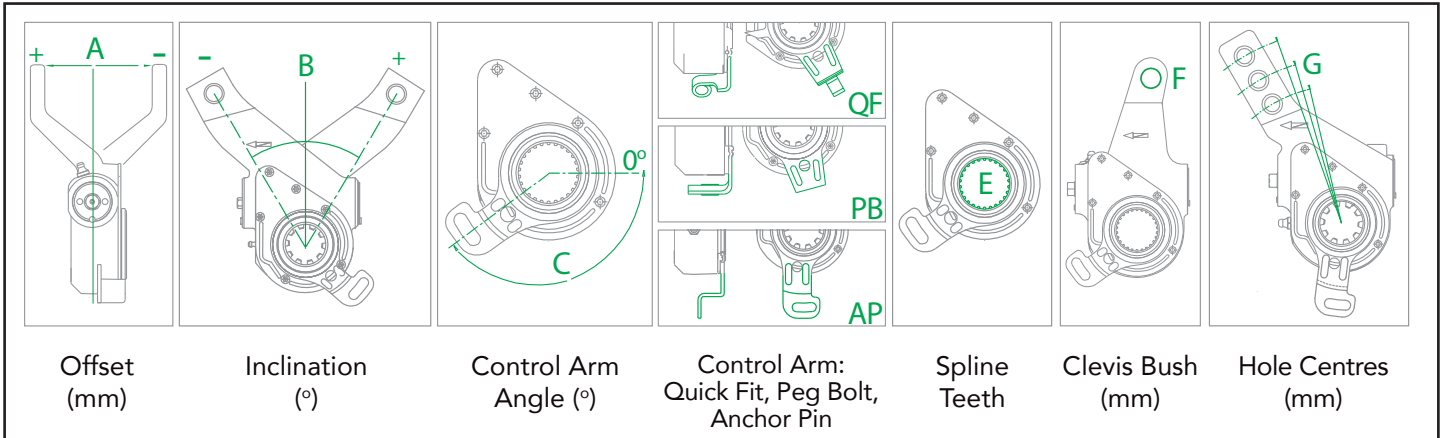

4W3400 **MAN Truck and Bus**



Haldex: 79207						
OEM: 81506106217						
Supplied With:						
Axle Side:L&R			Other Side: 4W3400			
A	B	C	D	E	F	
0	0	110°	AP	26	14.2	
G1	G2	G3	G4	G5	G6	G7
145						

4W3405 **Bova Bus**



Haldex: 11011						
OEM:						
Supplied With: K0270						
Axle Side:L&R			Other Side: 4W3405			
A	B	C	D	E	F	
0	0	150°	PB	10	14.2	
G1	G2	G3	G4	G5	G6	G7
140						

4W3410 **Van Hool Bus**



Haldex: 79163						
OEM: 10551439						
Supplied With:						
Axle Side:R			Other Side: 4W3415			
A	B	C	D	E	F	
-45	0	4°	AP	10	14.2	
G1	G2	G3	G4	G5	G6	G7
152						

4W3415 **Van Hool Bus**



Haldex: 79162						
OEM:						
Supplied With:						
Axle Side:L			Other Side: 4W3410			
A	B	C	D	E	F	
+45	0	4°	AP	10	14.2	
G1	G2	G3	G4	G5	G6	G7
152						

4W3420 **MAN Bus**



Haldex: 79218						
OEM: 81506106226						
Supplied With:						
Axle Side:L&R			Other Side: 4W3420			
A	B	C	D	E	F	
0	0	104°	AP	26	14.2	
G1	G2	G3	G4	G5	G6	G7
130						

4W3425 **DAF Truck**



Haldex: 79024						
OEM: 1282111						
Supplied With:						
Axle Side:L			Other Side: 4W3430			
A	B	C	D	E	F	
+12	-38	332°	AP	10	14.2	
G1	G2	G3	G4	G5	G6	G7
165						

TRUCK AND BUS

4W3430

DAF Truck



Haldex: 79025						
OEM: 1282112						
Supplied With:						
Axle Side:R			Other Side: 4W3425			
A	B	C	D	E	F	
-12	-38	332°	AP	10	14.2	
G1	G2	G3	G4	G5	G6	G7
165						

4W3435



Haldex: 72329						
OEM:						
Supplied With: K0270						
Axle Side:L&R			Other Side: 4W3435			
A	B	C	D	E	F	
0	0	31°	PB	10	12.9	
G1	G2	G3	G4	G5	G6	G7
127	155					

4W3440

Foden Truck



Haldex: 72417						
OEM:						
Supplied With:						
Axle Side:R			Other Side: 4W3445			
A	B	C	D	E	F	
-38	0	336°	AP	10	12.9	
G1	G2	G3	G4	G5	G6	G7
165						

4W3445

Foden Truck



Haldex: 72418						
OEM:						
Supplied With:						
Axle Side:L			Other Side: 4W3440			
A	B	C	D	E	F	
+38	0	336°	AP	10	12.9	
G1	G2	G3	G4	G5	G6	G7
165						

4W3450

Sisu



Haldex: 72429						
OEM: 1465300811						
Supplied With:						
Axle Side:L&R			Other Side: 4W3450			
A	B	C	D	E	F	
0	0	113°	AP	10	14.2	
G1	G2	G3	G4	G5	G6	G7
145						

4W3455

Sisu



Haldex: 72428						
OEM: 1465300611						
Supplied With:						
Axle Side:L&R			Other Side: 4W3455			
A	B	C	D	E	F	
0	0	44°	AP	10	14.2	
G1	G2	G3	G4	G5	G6	G7
145						

4W3460

Foden Truck



Haldex: 72568						
OEM:						
Supplied With:						
Axle Side:L&R			Other Side: 4W3460			
A	B	C	D	E	F	
0	0	337°	AP	10	12.9	
G1	G2	G3	G4	G5	G6	G7
165						

4W3465

Iveco Truck



Haldex: 72035						
OEM:						
Supplied With:						
Axle Side:L&R			Other Side: 4W3465			
A	B	C	D	E	F	
0	+139	340°	AP	8	12.9	
G1	G2	G3	G4	G5	G6	G7
190						

TRUCK AND BUS

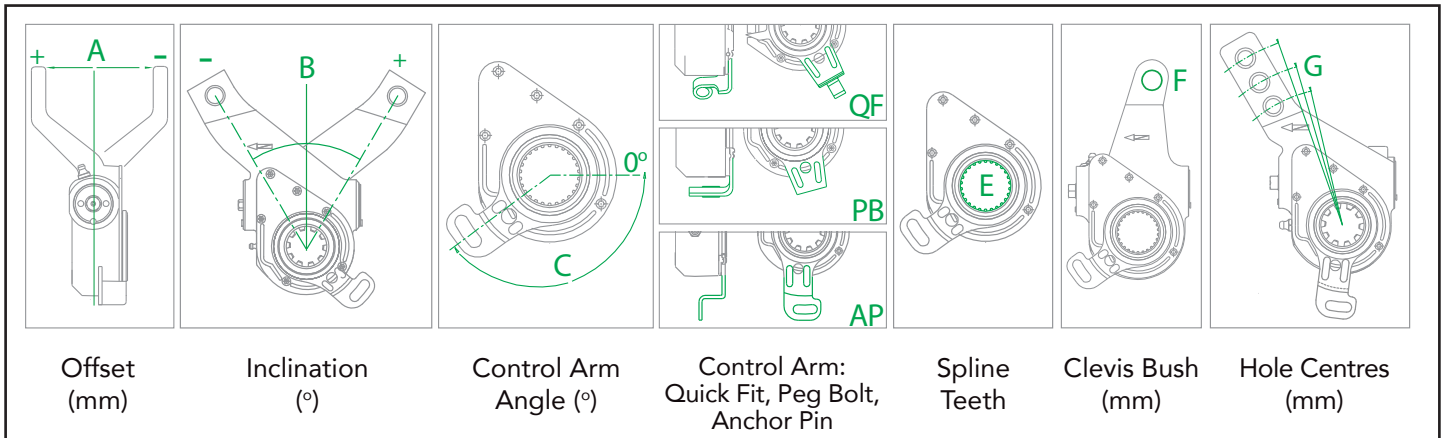

4W3470 **Iveco Truck**



Haldex: 72034						
OEM:						
Supplied With:						
Axle Side:	Other Side: 4W3475					
A	B	C	D	E	F	
+12	0	106°	AP	8	12.9	
G1	G2	G3	G4	G5	G6	G7
218						

4W3475 **Iveco Truck**



Haldex: 72033						
OEM:						
Supplied With:						
Axle Side:	Other Side: 4W3470					
A	B	C	D	E	F	
-12	0	106°	AP	8	12.9	
G1	G2	G3	G4	G5	G6	G7
218						

4W3480 **Mercedes Bus**



Haldex: 72178						
OEM: 3454201238						
Supplied With:						
Axle Side:L&R	Other Side: 4W3480					
A	B	C	D	E	F	
0	+172	152°	AP	26	14.2	
G1	G2	G3	G4	G5	G6	G7
145						

4W3485 **Renault Truck**



Haldex: 79304						
OEM: 5010260027						
Supplied With:						
Axle Side:L	Other Side: 4W3490					
A	B	C	D	E	F	
-38	0	352°	AP	28	14.2	
G1	G2	G3	G4	G5	G6	G7
160						

4W3490 **Renault Truck**



Haldex: 79305						
OEM: 5010260028						
Supplied With:						
Axle Side:R	Other Side: 4W3485					
A	B	C	D	E	F	
+38	0	352°	AP	28	14.2	
G1	G2	G3	G4	G5	G6	G7
160						

4W3495 **Iveco Bus**



Haldex: 70903						
OEM: 0178529						
Supplied With:						
Axle Side:L&R	Other Side: 4W3495					
A	B	C	D	E	F	
0	0	14°	AP	10	12.9	
G1	G2	G3	G4	G5	G6	G7
160						

TRUCK AND BUS

4W3500 **Iveco Bus**



Haldex: 72085						
OEM: 4940871						
Supplied With: K0270						
Axle Side:L&R			Other Side: 4W3500			
A	B	C	D	E	F	
0	0	31°	PB	10	12.9	
G1	G2	G3	G4	G5	G6	G7
133						

4W3505 **DAF Truck**



Haldex: 72586						
OEM: 0538470						
Supplied With:						
Axle Side:R			Other Side: 4W3510			
A	B	C	D	E	F	
-38	0	0°	AP	10	14.2	
G1	G2	G3	G4	G5	G6	G7
140						

4W3510 **DAF Truck**



Haldex: 72587						
OEM: 0538471						
Supplied With:						
Axle Side:L			Other Side: 4W3505			
A	B	C	D	E	F	
+38	0	0°	AP	10	14.2	
G1	G2	G3	G4	G5	G6	G7
140						

4W3515 **Renault**



Haldex: 72603						
OEM:						
Supplied With: K0270						
Axle Side:			Other Side: 4W3580			
A	B	C	D	E	F	
-60	+35	100°	PB	33	14.2	
G1	G2	G3	G4	G5	G6	G7
140						

4W3520 **Scania Truck**



Haldex: 72729						
OEM: 394195						
Supplied With:						
Axle Side:R			Other Side: 4W3525			
A	B	C	D	E	F	
+35	0	63°	AP	10	16.2	
G1	G2	G3	G4	G5	G6	G7
130						

4W3525 **Scania Truck**



Haldex: 72730						
OEM: 394196						
Supplied With:						
Axle Side:L			Other Side: 4W3520			
A	B	C	D	E	F	
-35	0	63°	AP	10	16.2	
G1	G2	G3	G4	G5	G6	G7
130						

4W3530

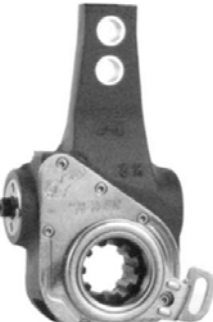

Haldex: 72817						
OEM:						
Supplied With:						
Axle Side:L&R			Other Side: 4W3530			
A	B	C	D	E	F	
0	0	16°	AP	10	14.2	
G1	G2	G3	G4	G5	G6	G7
125	150					

4W3535 **Pegaso Bus**



Haldex: 72831						
OEM: 914265						
Supplied With:						
Axle Side:L&R			Other Side: 4W3535			
A	B	C	D	E	F	
0	0	25°	AP	19	14.2	
G1	G2	G3	G4	G5	G6	G7
180						

TRUCK AND BUS

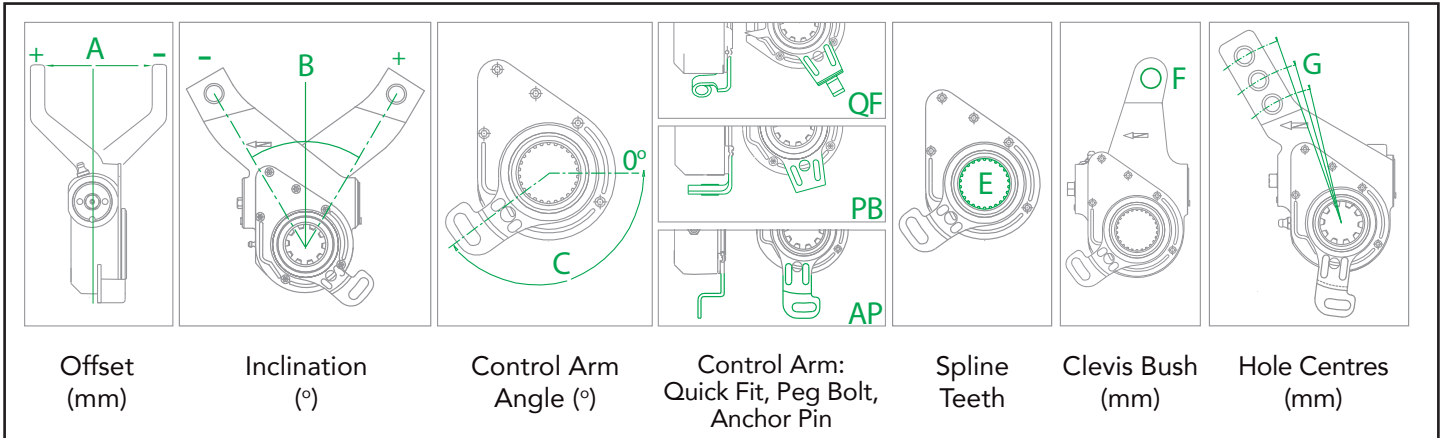

4W3540 Scania Truck and Bus



Haldex: 79348							
OEM: 1789564							
Supplied With:							
Axle Side:				Other Side: 4W3545			
A	B	C	D	E	F		
-25	+40	100°	AP	10	16.2		
G1	G2	G3	G4	G5	G6	G7	
165							

4W3545 Scania Truck and Bus



Haldex: 79347							
OEM: 1789563							
Supplied With:							
Axle Side:				Other Side: 4W3540			
A	B	C	D	E	F		
+25	+40	100°	AP	10	16.2		
G1	G2	G3	G4	G5	G6	G7	
165							

4W3550 Scania Truck and Bus



Haldex: 79105							
OEM: 1324357							
Supplied With:							
Axle Side:				Other Side: 4W3555			
A	B	C	D	E	F		
-75	0	55°	AP	10	16.2		
G1	G2	G3	G4	G5	G6	G7	
165							

4W3555 Scania Truck and Bus



Haldex: 79106							
OEM: 1324358							
Supplied With:							
Axle Side:				Other Side: 4W3550			
A	B	C	D	E	F		
+75	0	55°	AP	10	16.2		
G1	G2	G3	G4	G5	G6	G7	
165							

4W3560 Scania Truck and Bus



Haldex: 79454							
OEM:							
Supplied With:							
Axle Side:L&R				Other Side: 4W3560			
A	B	C	D	E	F		
0	0	105°	AP	24	14.2		
G1	G2	G3	G4	G5	G6	G7	
160							

4W3565 Scania Truck and Bus



Haldex: 79455							
OEM:							
Supplied With:							
Axle Side:				Other Side: 4W3570			
A	B	C	D	E	F		
-29	0	91°	AP	10	14.2		
G1	G2	G3	G4	G5	G6	G7	
160							

TRUCK AND BUS

4W3570



Haldex: 79456						
OEM:						
Supplied With:						
Axle Side:			Other Side: 4W3565			
A	B	C	D	E	F	
+29	0	91°	AP	10	14.2	
G1	G2	G3	G4	G5	G6	G7
160						

4W3575

Kassbohrer Bus



Haldex: 72591						
OEM: 82850002130						
Supplied With: K0270						
Axle Side:R			Other Side: 4W2975			
A	B	C	D	E	F	
-38	0	145°	PB	19	14.2	
G1	G2	G3	G4	G5	G6	G7
150						

4W3580

Renault



Haldex: 72604						
OEM:						
Supplied With: K0270						
Axle Side:			Other Side: 4W3515			
A	B	C	D	E	F	
+48	+23	100°	PB	33	14.2	
G1	G2	G3	G4	G5	G6	G7
140						

4W3585

Tatra Truck



Haldex: 72760						
OEM:						
Supplied With:						
Axle Side:			Other Side: 4W3590			
A	B	C	D	E	F	
-22	0	114°	AP	36	14.2	
G1	G2	G3	G4	G5	G6	G7
140						

4W3590

Tatra Truck



Haldex: 72759						
OEM:						
Supplied With:						
Axle Side:			Other Side: 4W3585			
A	B	C	D	E	F	
+22	0	114°	AP	36	14.2	
G1	G2	G3	G4	G5	G6	G7
140						

4W3595

Daewoo Bus



Haldex: 79250						
OEM:						
Supplied With:						
Axle Side:L			Other Side: 4W3600			
A	B	C	D	E	F	
+60	-28	5°	AP	25	16.2	
G1	G2	G3	G4	G5	G6	G7
150						

4W3600

Daewoo Bus



Haldex: 79251						
OEM:						
Supplied With:						
Axle Side:R			Other Side: 4W3595			
A	B	C	D	E	F	
-60	-28	5°	AP	25	16.2	
G1	G2	G3	G4	G5	G6	G7
150						

4W3605

Daewoo Bus



Haldex: 72858						
OEM:						
Supplied With:						
Axle Side:L&R			Other Side: 4W3605			
A	B	C	D	E	F	
0	0	42°	AP	25	16.2	
G1	G2	G3	G4	G5	G6	G7
150						

TRUCK AND BUS

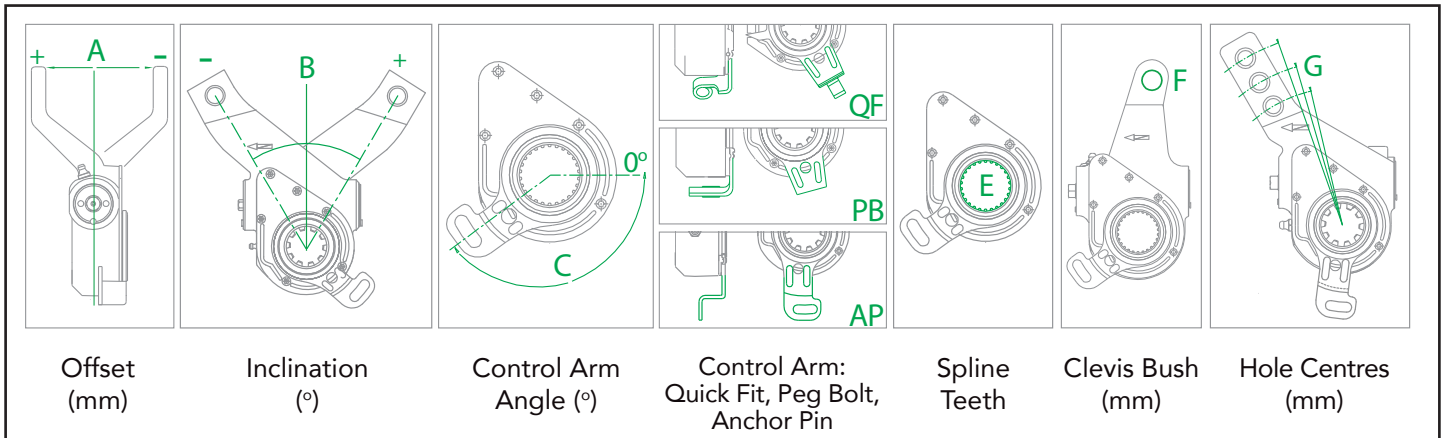

4W3610 **Kia Truck**



Haldex: 79071						
OEM: R9813F						
Supplied With:						
Axle Side:L&R			Other Side: 4W3610			
A	B	C	D	E	F	
0	0	60°	AP	10	12.9	
G1	G2	G3	G4	G5	G6	G7
165						

4W3615



Haldex: 79055						
OEM:						
Supplied With: K0270						
Axle Side:			Other Side:			
A	B	C	D	E	F	
+29	0	130°	PB	10	14.2	
G1	G2	G3	G4	G5	G6	G7
150	180					

4W3620 **Steyr Truck**



Haldex: 72643						
OEM:						
Supplied With:						
Axle Side:L&R			Other Side: 4W3620			
A	B	C	D	E	F	
0	0	151°	AP	10	12.9	
G1	G2	G3	G4	G5	G6	G7
140						

4W3625 **MAN Bus**



Haldex: 79215						
OEM: 81506106209						
Supplied With:						
Axle Side:L&R			Other Side: 4W3625			
A	B	C	D	E	F	
0	-38	30°	AP	26	14.2	
G1	G2	G3	G4	G5	G6	G7
130						

4W3630 **Steyr Truck**



Haldex: 72430						
OEM:						
Supplied With: K0270						
Axle Side:			Other Side: 4W3635			
A	B	C	D	E	F	
+38	0	30°	PB	28	12.9	
G1	G2	G3	G4	G5	G6	G7
150						

4W3635 **Steyr Truck**



Haldex: 72431						
OEM:						
Supplied With: K0270						
Axle Side:			Other Side: 4W3630			
A	B	C	D	E	F	
-38	0	30°	PB	28	12.9	
G1	G2	G3	G4	G5	G6	G7
150						

TRUCK AND BUS

4W3640 **Hyundai Truck and Bus**



Haldex: 72778						
OEM:						
Supplied With:						
Axle Side:L&R			Other Side: 4W3640			
A	B	C	D	E	F	
0	-38	25°	AP	10	16.2	
G1	G2	G3	G4	G5	G6	G7
145						

4W3645 **Iveco Bus**



Haldex: 72929						
OEM: 3231273						
Supplied With:						
Axle Side:			Other Side: 4W3650			
A	B	C	D	E	F	
+50	+22	141°	AP	19	14.2	
G1	G2	G3	G4	G5	G6	G7
150						

4W3650 **Iveco Bus**



Haldex: 72930						
OEM: 3231343						
Supplied With:						
Axle Side:			Other Side: 4W3645			
A	B	C	D	E	F	
-29	0	120°	AP	19	14.2	
G1	G2	G3	G4	G5	G6	G7
150						

4W3655 **DAF Truck**



Haldex: 72544						
OEM: 0159563						
Supplied With:						
Axle Side:L			Other Side: 4W3660			
A	B	C	D	E	F	
-56	+4	80°	AP	10	14.2	
G1	G2	G3	G4	G5	G6	G7
140						

4W3660 **DAF Truck**



Haldex: 72545						
OEM: 0159564						
Supplied With:						
Axle Side:R			Other Side: 4W3655			
A	B	C	D	E	F	
+56	+4	80°	AP	10	14.2	
G1	G2	G3	G4	G5	G6	G7
140						

4W3665 **DAF Truck**



Haldex: 72547						
OEM: 0159576						
Supplied With:						
Axle Side:L&R			Other Side: 4W3665			
A	B	C	D	E	F	
0	-38	41°	AP	10	14.2	
G1	G2	G3	G4	G5	G6	G7
165						

4W3670 **Liaz Truck**



Haldex: 72357						
OEM:						
Supplied With: K0270						
Axle Side:L			Other Side: 4W3675			
A	B	C	D	E	F	
-29	+38	31°	PB	26	14.2	
G1	G2	G3	G4	G5	G6	G7
150						

4W3675 **Liaz Truck**



Haldex: 72358						
OEM:						
Supplied With: K0270						
Axle Side:R			Other Side: 4W3670			
A	B	C	D	E	F	
+29	+38	31°	PB	26	14.2	
G1	G2	G3	G4	G5	G6	G7
150						

TRUCK AND BUS

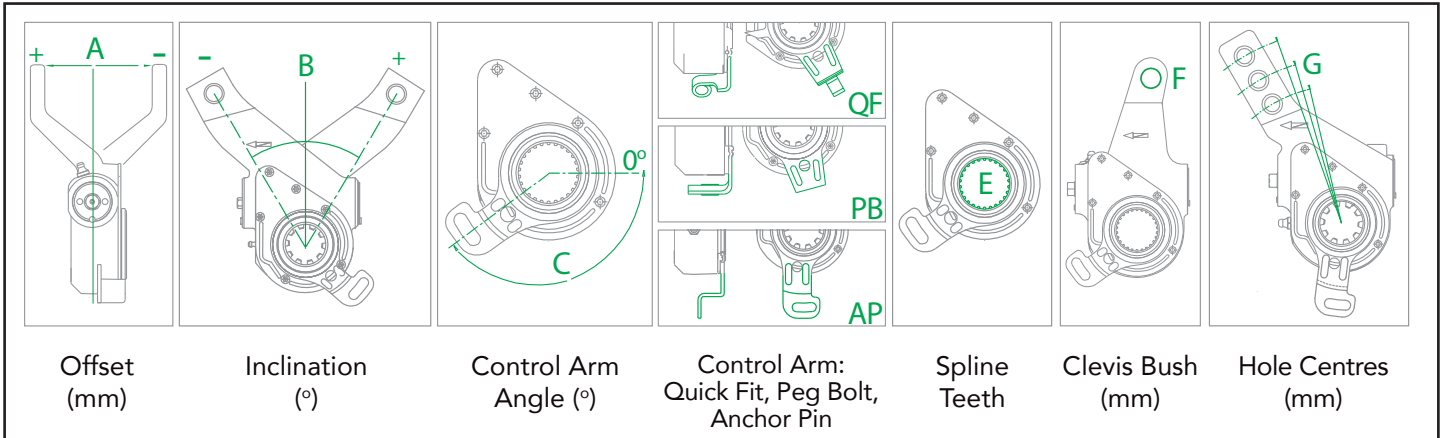

4W3680		Kassbohrer Bus					
	Haldex: 79040						
	OEM: 82850000900						
	Supplied With: K0270						
	Axle Side:L			Other Side: 4W3685			
	A	B	C	D	E	F	
-38	0	140°	PB	19	14.2		
G1	G2	G3	G4	G5	G6	G7	
175							

4W3685		Kassbohrer Bus					
	Haldex: 79041						
	OEM: 82850000890						
	Supplied With: K0270						
	Axle Side:R			Other Side: 4W3680			
	A	B	C	D	E	F	
+38	0	140°	PB	19	14.2		
G1	G2	G3	G4	G5	G6	G7	
175							

4W3690		MAN Truck					
	Haldex: 79221						
	OEM: 81506106219						
	Supplied With:						
	Axle Side:L			Other Side: 4W3695			
	A	B	C	D	E	F	
-26	+11	90°	AP	26	14.2		
G1	G2	G3	G4	G5	G6	G7	
215							

4W3695		MAN Truck					
	Haldex: 79222						
	OEM: 81506106218						
	Supplied With:						
	Axle Side:R			Other Side: 4W3690			
	A	B	C	D	E	F	
+26	+11	90°	AP	26	14.2		
G1	G2	G3	G4	G5	G6	G7	
215							

4W3700		DAF Truck					
	Haldex: 72704						
	OEM: 0755616						
	Supplied With:						
	Axle Side:			Other Side: 4W3705			
	A	B	C	D	E	F	
+60	-10	339°	AP	10	14.2		
G1	G2	G3	G4	G5	G6	G7	
145							

4W3705		DAF Truck					
	Haldex: 72705						
	OEM: 0755617						
	Supplied With:						
	Axle Side:			Other Side: 4W3700			
	A	B	C	D	E	F	
-60	-10	339°	AP	10	14.2		
G1	G2	G3	G4	G5	G6	G7	
145							

TRUCK AND BUS

4W3710

Volvo Truck



Haldex: 72725						
OEM: 1592875						
Supplied With: K0270						
Axle Side:L&R			Other Side: 4W3710			
A	B	C	D	E	F	
0	0	90°	PB	10	12.9	
G1	G2	G3	G4	G5	G6	G7
127						

4W3715

Scania Bus



Haldex: 72484						
OEM: 394183						
Supplied With:						
Axle Side:			Other Side: 4W3720			
A	B	C	D	E	F	
+35	0	75°	AP	10	14.2	
G1	G2	G3	G4	G5	G6	G7
130						

4W3720

Scania Bus



Haldex: 72485						
OEM: 394184						
Supplied With:						
Axle Side:			Other Side: 4W3715			
A	B	C	D	E	F	
-35	0	75°	AP	10	16.2	
G1	G2	G3	G4	G5	G6	G7
130						

4W3725

MAN Truck



Haldex: 79195						
OEM: 81506106161						
Supplied With:						
Axle Side:			Other Side: 4W3730			
A	B	C	D	E	F	
-56	-15	119°	AP	26	14.2	
G1	G2	G3	G4	G5	G6	G7
145						

4W3730

MAN Truck



Haldex: 79196						
OEM: 81506106160						
Supplied With:						
Axle Side:			Other Side: 4W3725			
A	B	C	D	E	F	
+56	-15	119°	AP	26	14.2	
G1	G2	G3	G4	G5	G6	G7
145						

4W3740

Sicca Bus



Haldex: 72419						
OEM:						
Supplied With:						
Axle Side:L&R			Other Side: 4W3740			
A	B	C	D	E	F	
0	0	100°	AP	8	12.9	
G1	G2	G3	G4	G5	G6	G7
180						

4W3745

Graziano Bus



Haldex: 79064						
OEM:						
Supplied With:						
Axle Side:R			Other Side: 4W3750			
A	B	C	D	E	F	
-22	0	65°	AP	19	14.2	
G1	G2	G3	G4	G5	G6	G7
150						

4W3750

Graziano Bus



Haldex: 79063						
OEM:						
Supplied With:						
Axle Side:L			Other Side: 4W3745			
A	B	C	D	E	F	
+22	0	65°	AP	19	14.2	
G1	G2	G3	G4	G5	G6	G7
150						

TRUCK AND BUS

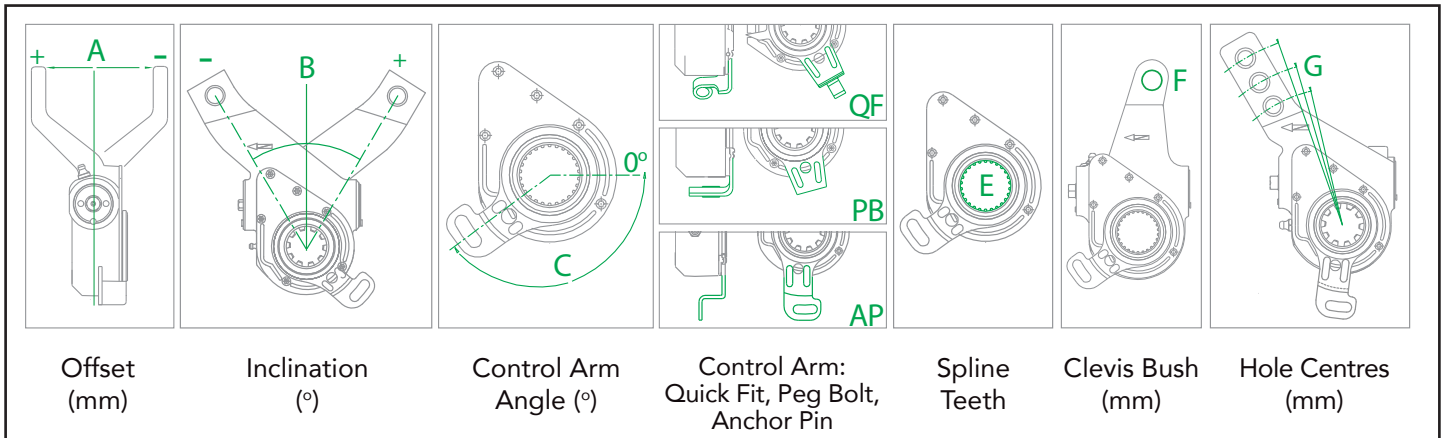

4W3755 Renault



Haldex: 79441						
OEM:						
Supplied With:						
Axle Side:			Other Side: 4W4200			
A	B	C	D	E	F	
+56	+25	350°	AP	27	14.2	
G1	G2	G3	G4	G5	G6	G7
160						

4W3760 DAB Bus



Haldex: 72680						
OEM: 0097775						
Supplied With:						
Axle Side:L			Other Side: 4W3790			
A	B	C	D	E	F	
-38	-34	35°	AP	10	14.2	
G1	G2	G3	G4	G5	G6	G7
140						

4W3765 Daewoo Truck and Bus



Haldex: 72856						
OEM:						
Supplied With:						
Axle Side:L			Other Side: 4W3770			
A	B	C	D	E	F	
+60	+23	130°	AP	25	16.2	
G1	G2	G3	G4	G5	G6	G7
150						

4W3770 Daewoo Truck and Bus



Haldex: 72857						
OEM:						
Supplied With:						
Axle Side:R			Other Side: 4W3765			
A	B	C	D	E	F	
-60	+23	130°	AP	25	16.2	
G1	G2	G3	G4	G5	G6	G7
150						

4W3775



Haldex: 72179						
OEM:						
Supplied With:						
Axle Side:L&R			Other Side: 4W3775			
A	B	C	D	E	F	
0	-38	348°	AP	10	12.9	
G1	G2	G3	G4	G5	G6	G7
127						

4W3780



Haldex: 70869						
OEM:						
Supplied With: K0270						
Axle Side:			Other Side:			
A	B	C	D	E	F	
-22	0	150°	PB	19	14.2	
G1	G2	G3	G4	G5	G6	G7
200						

TRUCK AND BUS

4W3790 **DAB Bus**



Haldex: 72679						
OEM: 0097774						
Supplied With:						
Axle Side:R			Other Side: 4W3760			
A	B	C	D	E	F	
+38	+34	37°	AP	10	14.2	
G1	G2	G3	G4	G5	G6	G7
140						

4W3795 **Mercedes Truck**



Haldex: 72054						
OEM: 6234200038						
Supplied With:						
Axle Side:L			Other Side: 4W3800			
A	B	C	D	E	F	
+60	-10	90°	AP	26	14.2	
G1	G2	G3	G4	G5	G6	G7
145						

4W3800 **Mercedes Truck**



Haldex: 72055						
OEM: 6234200138						
Supplied With:						
Axle Side:R			Other Side: 4W3795			
A	B	C	D	E	F	
-60	-10	90°	AP	26	14.2	
G1	G2	G3	G4	G5	G6	G7
145						

4W3805 **Volvo Bus**



Haldex: 72721						
OEM: 1134829						
Supplied With: K0270						
Axle Side:L			Other Side: 4W3810			
A	B	C	D	E	F	
+13	0	58°	PB	10	12.9	
G1	G2	G3	G4	G5	G6	G7
160						

4W3810 **Volvo Bus**



Haldex: 72722						
OEM: 1134830						
Supplied With: K0270						
Axle Side:R			Other Side: 4W3805			
A	B	C	D	E	F	
-13	0	58°	PB	10	12.9	
G1	G2	G3	G4	G5	G6	G7
160						

4W3815 **Mercedes Bus**



Haldex: 72811						
OEM: 3574201538						
Supplied With:						
Axle Side:L			Other Side: 4W3820			
A	B	C	D	E	F	
-18	+34	53°	AP	26	14.2	
G1	G2	G3	G4	G5	G6	G7
130						

4W3820 **Mercedes Bus**



Haldex: 72812						
OEM: 3574201638						
Supplied With:						
Axle Side:R			Other Side: 4W3815			
A	B	C	D	E	F	
+18	+34	53°	AP	26	14.2	
G1	G2	G3	G4	G5	G6	G7
130						

4W3825 **Renault Truck**



Haldex: 79009						
OEM: 5000788696						
Supplied With: K0270						
Axle Side:R			Other Side: 4W3830			
A	B	C	D	E	F	
+38	+30	155°	PB	27	14.2	
G1	G2	G3	G4	G5	G6	G7
175						

TRUCK AND BUS

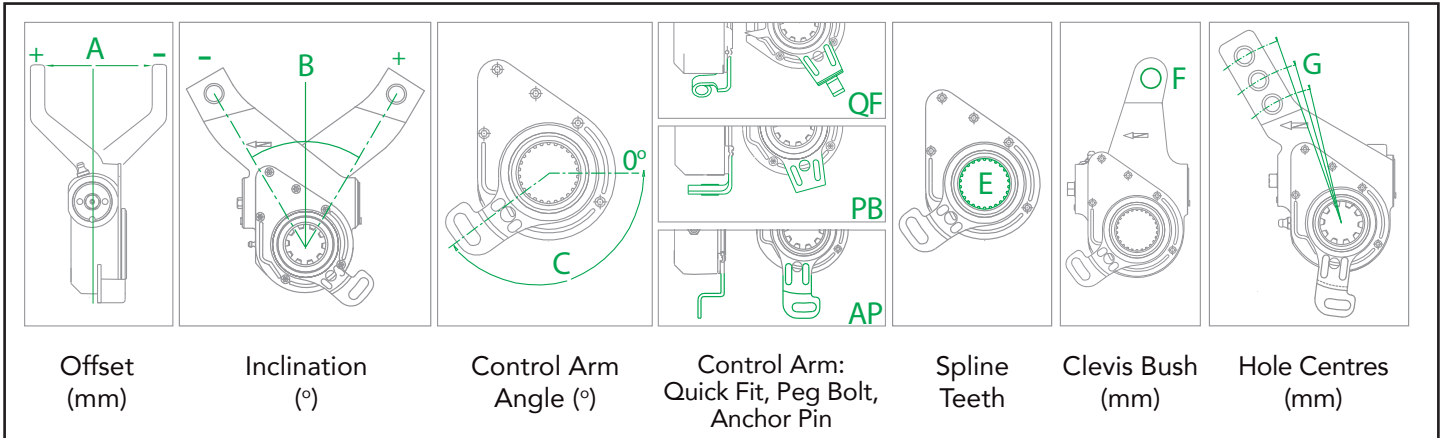

4W3830 Renault Truck



Haldex: 79010						
OEM: 5000788697						
Supplied With: K0270						
Axle Side:L			Other Side: 4W3825			
A	B	C	D	E	F	
-38	+30	155°	PB	27	14.2	
G1	G2	G3	G4	G5	G6	G7
175						

4W3835 Renault Truck



Haldex: 79012						
OEM: 5000445898						
Supplied With:						
Axle Side:L&R			Other Side: 4W3835			
A	B	C	D	E	F	
0	0	4°	AP	27	14.2	
G1	G2	G3	G4	G5	G6	G7
140						

4W3840 Renault Truck



Haldex: 79306						
OEM: 5010260023						
Supplied With:						
Axle Side:L			Other Side: 4W3845			
A	B	C	D	E	F	
-38	0	350°	AP	27	14.2	
G1	G2	G3	G4	G5	G6	G7
175						

4W3845 Renault Truck



Haldex: 79307						
OEM: 5010260024						
Supplied With:						
Axle Side:R			Other Side: 4W3840			
A	B	C	D	E	F	
+38	0	350°	AP	27	14.2	
G1	G2	G3	G4	G5	G6	G7
175						

4W3850 Renault Truck



Haldex: 79312						
OEM: 5010260379						
Supplied With:						
Axle Side:R			Other Side: 4W3855			
A	B	C	D	E	F	
+38	+30	63°	AP	27	14.2	
G1	G2	G3	G4	G5	G6	G7
175						

4W3855 Renault Truck



Haldex: 79313						
OEM: 5010260380						
Supplied With:						
Axle Side:L			Other Side: 4W3850			
A	B	C	D	E	F	
-38	+30	63°	AP	27	14.2	
G1	G2	G3	G4	G5	G6	G7
175						

TRUCK AND BUS

4W3860

Dongfeng Bus



Haldex: 79569						
OEM:						
Supplied With:						
Axle Side:L&R			Other Side: 4W3860			
A	B	C	D	E	F	
0	0	28°	AP	10	12.25	
G1	G2	G3	G4	G5	G6	G7
125						

4W3865

Dongfeng Bus



Haldex: 79567						
OEM:						
Supplied With: K0270						
Axle Side:L			Other Side: 4W3870			
A	B	C	D	E	F	
-50	0	90°	PB	10	12.25	
G1	G2	G3	G4	G5	G6	G7
130						

4W3870

Dongfeng Bus



Haldex: 79568						
OEM:						
Supplied With: K0270						
Axle Side:R			Other Side: 4W3865			
A	B	C	D	E	F	
+50	0	90°	PB	10	12.25	
G1	G2	G3	G4	G5	G6	G7
130						

4W3890

Mercedes Bus



Haldex: 72064						
OEM: 3074201738						
Supplied With: K0270						
Axle Side:L			Other Side: 4W3895			
A	B	C	D	E	F	
-63	-20	48°	PB	26	14.2	
G1	G2	G3	G4	G5	G6	G7
145						

4W3895

Mercedes Bus



Haldex: 72065						
OEM: 3074201838						
Supplied With: K0270						
Axle Side:R			Other Side: 4W3890			
A	B	C	D	E	F	
+63	+20	48°	PB	26	14.2	
G1	G2	G3	G4	G5	G6	G7
145						

4W3900

Liaz Bus



Haldex: 79056						
OEM:						
Supplied With:						
Axle Side:L&R			Other Side: 4W3900			
A	B	C	D	E	F	
0	0	76°	AP	20	14.2	
G1	G2	G3	G4	G5	G6	G7
175						

4W3905

Liaz Bus



Haldex: 79079						
OEM:						
Supplied With:						
Axle Side:L&R			Other Side: 4W3905			
A	B	C	D	E	F	
0	-38	50°	AP	20	14.2	
G1	G2	G3	G4	G5	G6	G7
175						

4W3910

Volvo Bus



Haldex: 79677						
OEM: 3193400						
Supplied With: K0270						
Axle Side:L			Other Side: 4W3915			
A	B	C	D	E	F	
-50	0	336°	PB	10	12.9	
G1	G2	G3	G4	G5	G6	G7
165						

TRUCK AND BUS

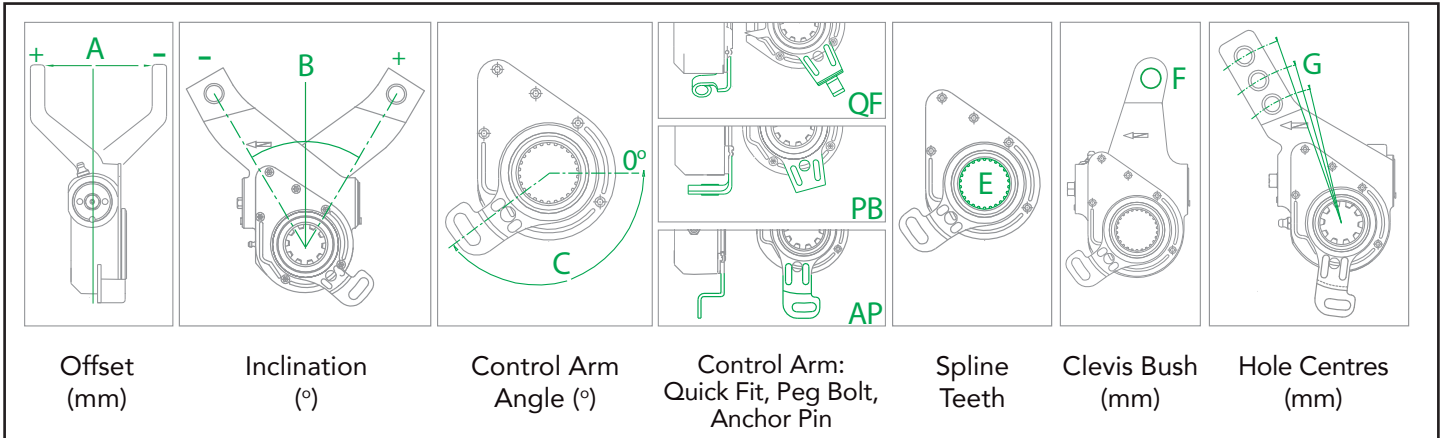

4W3915		Volvo Bus					
	Haldex: 79678						
	OEM: 3193401						
	Supplied With: K0270						
	Axle Side:R			Other Side: 4W3910			
	A	B	C	D	E	F	
+50	0	336°	PB	10	12.9		
G1	G2	G3	G4	G5	G6	G7	
165							

4W3920		Dongfeng Bus					
	Haldex: 79351						
	OEM:						
	Supplied With: K0270						
	Axle Side:L			Other Side: 4W3925			
	A	B	C	D	E	F	
+50	+22	130°	PB	14	12.25		
G1	G2	G3	G4	G5	G6	G7	
135	165						

4W3925		Dongfeng Bus					
	Haldex: 79352						
	OEM:						
	Supplied With: K0270						
	Axle Side:R			Other Side: 4W3920			
	A	B	C	D	E	F	
-50	+22	130°	PB	14	12.25		
G1	G2	G3	G4	G5	G6	G7	
135	165						

4W3930		Dongfeng Bus					
	Haldex: 79353						
	OEM:						
	Supplied With: K0270						
	Axle Side:L&R			Other Side: 4W3930			
	A	B	C	D	E	F	
0	-38	14°	PB	14	12.25		
G1	G2	G3	G4	G5	G6	G7	
135							

4W3935		Scania Bus					
	Haldex: 72953						
	OEM: 308677						
	Supplied With: K0270						
	Axle Side:L&R			Other Side: 4W3935			
	A	B	C	D	E	F	
0	0	305°	PB	10	16.2		
G1	G2	G3	G4	G5	G6	G7	
140	165						

4W3940		Iveco Bus					
	Haldex: 72425						
	OEM: 1042976						
	Supplied With: K0270						
	Axle Side:R			Other Side: 4W4020			
	A	B	C	D	E	F	
0	0	75°	PB	10	12.9		
G1	G2	G3	G4	G5	G6	G7	
145							

TRUCK AND BUS

4W3945 **Saurer Truck**



Haldex:						
OEM:						
Supplied With: K0270						
Axle Side:			Other Side:			
A	B	C	D	E	F	
-60	+23	114°	PB	19	14.2	
G1	G2	G3	G4	G5	G6	G7
150	180					

4W3950 **Liaz Bus**



Haldex: 72928						
OEM:						
Supplied With:						
Axle Side:L&R			Other Side: 4W3950			
A	B	C	D	E	F	
0	0	135°	AP	20	14.2	
G1	G2	G3	G4	G5	G6	G7
127	155					

4W3955 **Van Hool Bus**



Haldex: 72921						
OEM:						
Supplied With: K0270						
Axle Side:			Other Side: 4W3960			
A	B	C	D	E	F	
+60	-10	50°	PB	19	14.2	
G1	G2	G3	G4	G5	G6	G7
152						

4W3960 **Van Hool Bus**



Haldex: 72922						
OEM:						
Supplied With:						
Axle Side:			Other Side: 4W3955			
A	B	C	D	E	F	
-60	-10	50°	AP	19	14.2	
G1	G2	G3	G4	G5	G6	G7
152						

4W3965 **Sisu**



Haldex: 79396						
OEM: 5465302011						
Supplied With:						
Axle Side:			Other Side: 4W3970			
A	B	C	D	E	F	
-75	0	0°	AP	26	14.2	
G1	G2	G3	G4	G5	G6	G7
165						

4W3970 **Sisu**



Haldex: 79397						
OEM: 5465302021						
Supplied With:						
Axle Side:			Other Side: 4W3965			
A	B	C	D	E	F	
+75	0	0°	AP	26	14.2	
G1	G2	G3	G4	G5	G6	G7
165						

4W3975 **DAF Truck and Bus**



Haldex: 72833						
OEM: 1242597						
Supplied With:						
Axle Side:			Other Side: 4W3980			
A	B	C	D	E	F	
-29	0	155°	AP	10	14.2	
G1	G2	G3	G4	G5	G6	G7
165						

4W3980 **DAF Truck and Bus**



Haldex: 72834						
OEM: 1242598						
Supplied With:						
Axle Side:			Other Side: 4W3975			
A	B	C	D	E	F	
+29	0	155°	AP	10	14.2	
G1	G2	G3	G4	G5	G6	G7
165						

TRUCK AND BUS

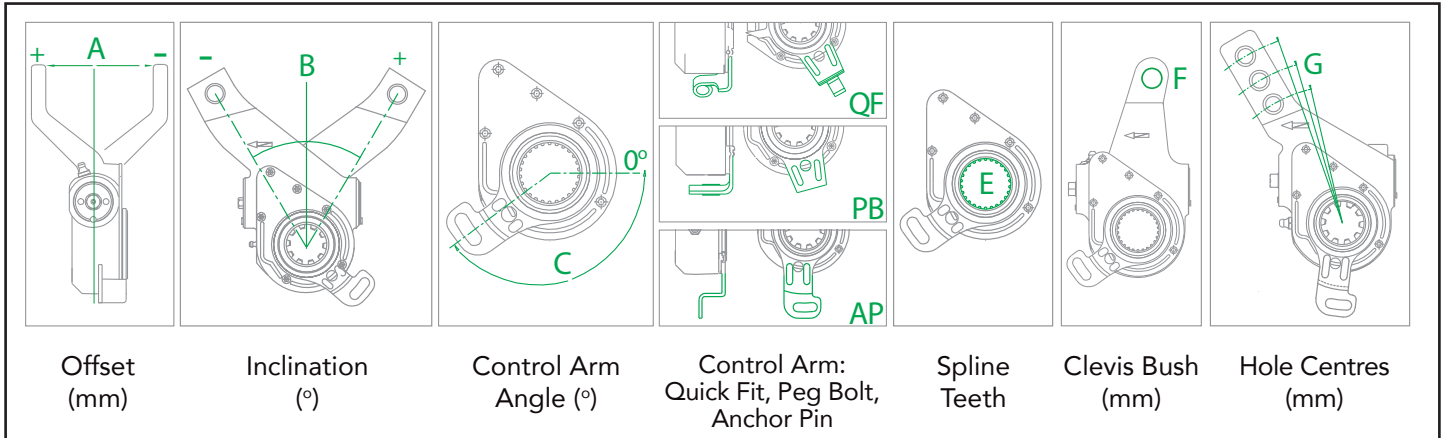

4W3995 **Panav**



Haldex: 72888						
OEM:						
Supplied With:						
Axle Side:L&R			Other Side: 4W3995			
A	B	C	D	E	F	
0	+20	73°	AP	20	14.2	
G1	G2	G3	G4	G5	G6	G7
150	175	200	225	250		

4W4000



Haldex: 79493						
OEM:						
Supplied With:						
Axle Side:			Other Side: 4W4005			
A	B	C	D	E	F	
-38	0	65°	AP	14	12.9	
G1	G2	G3	G4	G5	G6	G7
150						

4W4005



Haldex: 79494						
OEM:						
Supplied With:						
Axle Side:			Other Side: 4W4000			
A	B	C	D	E	F	
+38	0	65°	AP	14	12.9	
G1	G2	G3	G4	G5	G6	G7
150						

4W4010 **Mercedes Bus**



Haldex: 72060						
OEM: 3574200638						
Supplied With:						
Axle Side:R			Other Side: 4W4015			
A	B	C	D	E	F	
-15	-24	345°	AP	26	14.2	
G1	G2	G3	G4	G5	G6	G7
145						

4W4015 **Mercedes Bus**



Haldex: 72061						
OEM: 3574200738						
Supplied With:						
Axle Side:L			Other Side: 4W4010			
A	B	C	D	E	F	
+15	-24	345°	AP	26	14.2	
G1	G2	G3	G4	G5	G6	G7
145						

4W4020 **Saurer Truck**



Haldex:						
OEM:						
Supplied With:						
Axle Side:L			Other Side: 4W3945			
A	B	C	D	E	F	
+60	+23	114°	AP	19	14.2	
G1	G2	G3	G4	G5	G6	G7
150	180					

TRUCK AND BUS

4W4025

Karosa Bus



Haldex: 79059						
OEM:						
Supplied With:						
Axle Side:L			Other Side: 4W4030			
A	B	C	D	E	F	
-16	+7	0°	AP	26	14.2	
G1	G2	G3	G4	G5	G6	G7
240						

4W4030

Karosa Bus



Haldex: 79060						
OEM:						
Supplied With:						
Axle Side:R			Other Side: 4W4025			
A	B	C	D	E	F	
+16	+7	0°	AP	26	14.2	
G1	G2	G3	G4	G5	G6	G7
240						

4W4035

Karosa Bus



Haldex: 79057						
OEM:						
Supplied With: K0270						
Axle Side:L			Other Side: 4W4040			
A	B	C	D	E	F	
-22	0	25°	PB	26	14.2	
G1	G2	G3	G4	G5	G6	G7
170						

4W4040

Karosa Bus



Haldex: 79058						
OEM:						
Supplied With: K0270						
Axle Side:R			Other Side: 4W4035			
A	B	C	D	E	F	
+22	0	25°	PB	26	14.2	
G1	G2	G3	G4	G5	G6	G7
170						

4W4050

Kia Truck



Haldex: 72818						
OEM:						
Supplied With:						
Axle Side:L			Other Side: 4W4055			
A	B	C	D	E	F	
+60	+22.5	68°	AP	12	12.9	
G1	G2	G3	G4	G5	G6	G7
150						

4W4055

Kia Truck



Haldex: 72819						
OEM:						
Supplied With:						
Axle Side:R			Other Side: 4W4050			
A	B	C	D	E	F	
-60	+22.5	68°	AP	12	12.9	
G1	G2	G3	G4	G5	G6	G7
150						

4W4060

Hyundai Truck and Bus



Haldex: 72779						
OEM:						
Supplied With:						
Axle Side:L&R			Other Side: 4W4060			
A	B	C	D	E	F	
0	-38	352°	AP	10	16.2	
G1	G2	G3	G4	G5	G6	G7
135						

4W4065

Daewoo Bus



Haldex: 79412						
OEM:						
Supplied With: K0270						
Axle Side:L			Other Side: 4W4070			
A	B	C	D	E	F	
+60	+22.5	40°	PB	25	16.2	
G1	G2	G3	G4	G5	G6	G7
150						

TRUCK AND BUS

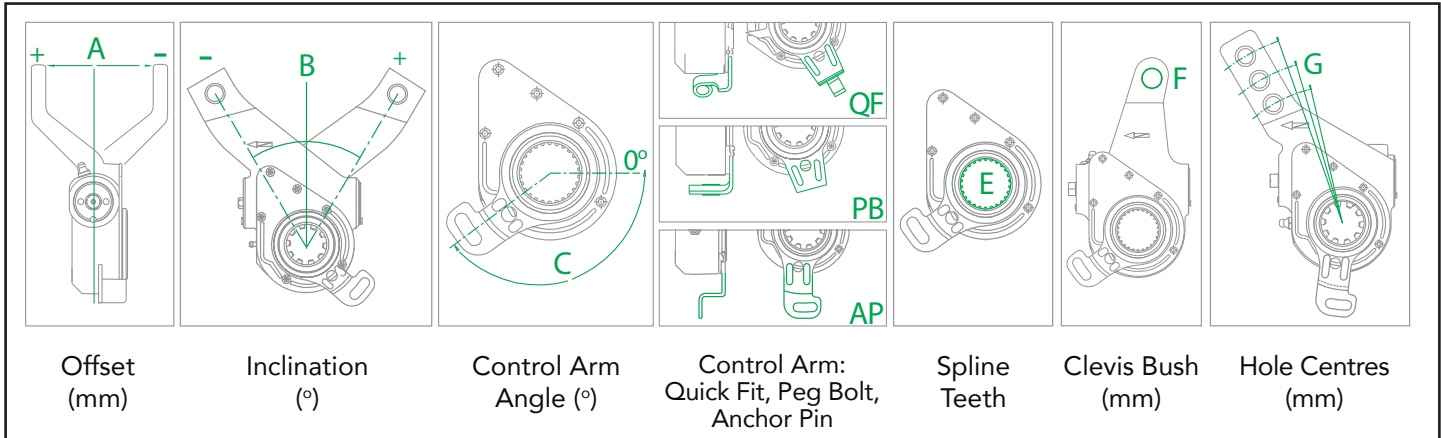

4W4070 **Daewoo Bus**



Haldex: 79413						
OEM:						
Supplied With: K0270						
Axle Side:R			Other Side: 4W4065			
A	B	C	D	E	F	
-60	+22.5	40°	PB	25	16.2	
G1	G2	G3	G4	G5	G6	G7
150						

4W4075 **Daewoo Truck and Bus**



Haldex: 79414						
OEM:						
Supplied With: K0270						
Axle Side:L			Other Side: 4W4080			
A	B	C	D	E	F	
+60	+22.5	130°	PB	25	16.2	
G1	G2	G3	G4	G5	G6	G7
150						

4W4080 **Daewoo Truck and Bus**



Haldex: 79415						
OEM:						
Supplied With: K0270						
Axle Side:R			Other Side: 4W4075			
A	B	C	D	E	F	
-60	+22.5	130°	PB	25	16.2	
G1	G2	G3	G4	G5	G6	G7
150						

4W4085 **Daewoo Bus**



Haldex: 79417						
OEM:						
Supplied With: K0270						
Axle Side:L			Other Side: 4W4090			
A	B	C	D	E	F	
+60	+28	5°	PB	25	16.2	
G1	G2	G3	G4	G5	G6	G7
150						

4W4090 **Daewoo Bus**



Haldex: 79418						
OEM:						
Supplied With: K0270						
Axle Side:R			Other Side: 4W4085			
A	B	C	D	E	F	
+60	+28	5°	PB	25	16.2	
G1	G2	G3	G4	G5	G6	G7
150						

4W4095 **Daewoo Bus**



Haldex: 79416						
OEM:						
Supplied With: K0270						
Axle Side:L&R			Other Side: 4W4095			
A	B	C	D	E	F	
0	0	40°	PB	25	16.2	
G1	G2	G3	G4	G5	G6	G7
150						

TRUCK AND BUS

4W4100 **Kia Truck**



Haldex: 72820						
OEM:						
Supplied With:						
Axle Side:L&R			Other Side: 4W4100			
A	B	C	D	E	F	
0	+38	52°	AP	14	12.9	
G1	G2	G3	G4	G5	G6	G7
150						

4W4105 **Hyundai Truck and Bus**



Haldex: 72772						
OEM:						
Supplied With:						
Axle Side:L			Other Side: 4W4110			
A	B	C	D	E	F	
+60	+34.5	150°	AP	10	14.2	
G1	G2	G3	G4	G5	G6	G7
145						

4W4110 **Hyundai Truck and Bus**



Haldex: 72773						
OEM:						
Supplied With:						
Axle Side:R			Other Side: 4W4105			
A	B	C	D	E	F	
+60	+34.5	150°	AP	10	14.2	
G1	G2	G3	G4	G5	G6	G7
145						

4W4115 **Renault Bus**



Haldex: 70542						
OEM:						
Supplied With: K0270						
Axle Side:L			Other Side: 4W4120			
A	B	C	D	E	F	
+33	0	90°	PB	27	14.2	
G1	G2	G3	G4	G5	G6	G7
260						

4W4120 **Renault Bus**



Haldex: 70543						
OEM:						
Supplied With: K0270						
Axle Side:R			Other Side: 4W4115			
A	B	C	D	E	F	
-33	0	90°	PB	27	14.2	
G1	G2	G3	G4	G5	G6	G7
260						

4W4125 **Renault Bus**



Haldex: 70975						
OEM:						
Supplied With: K0270						
Axle Side:L			Other Side: 4W4130			
A	B	C	D	E	F	
-12	0	90°	PB	27	14.2	
G1	G2	G3	G4	G5	G6	G7
240						

4W4130 **Renault Bus**



Haldex: 70976						
OEM:						
Supplied With: K0270						
Axle Side:R			Other Side: 4W4125			
A	B	C	D	E	F	
+12	0	90°	PB	27	14.2	
G1	G2	G3	G4	G5	G6	G7
240						

4W4135 **Foden Truck**



Haldex: 79133						
OEM:						
Supplied With: K0270						
Axle Side:L&R			Other Side: 4W4135			
A	B	C	D	E	F	
0	+20	355°	PB	28	12.9	
G1	G2	G3	G4	G5	G6	G7
140						

TRUCK AND BUS

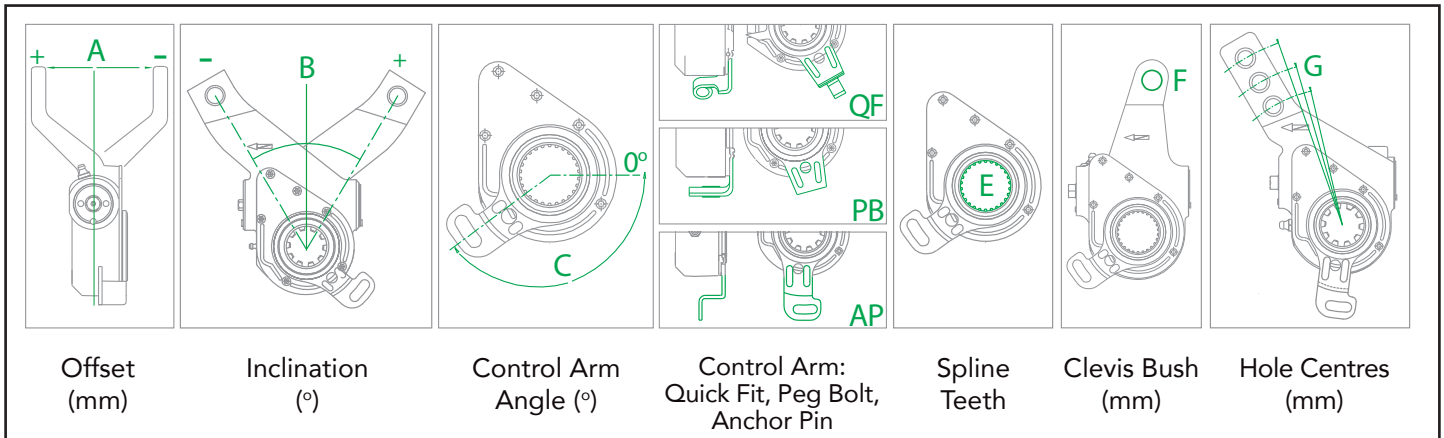

4W4140		Foden Truck					
	Haldex: 79184						
	OEM:						
	Supplied With:						
	Axle Side:L&R			Other Side: 4W4140			
A	B	C	D	E	F		
0	-38	75°	AP	28	12.9		
G1	G2	G3	G4	G5	G6	G7	
127							

4W4145		Foden Truck					
	Haldex: 79461						
	OEM:						
	Supplied With:						
	Axle Side:L&R			Other Side: 4W4145			
A	B	C	D	E	F		
0	-38	75°	AP	28	12.9		
G1	G2	G3	G4	G5	G6	G7	
140							

4W4170		Mercedes Truck					
	Haldex: 70870						
	OEM:						
	Supplied With:						
	Axle Side:L&R			Other Side: 4W4170			
A	B	C	D	E	F		
0	+120	114°	AP	26	14.2		
G1	G2	G3	G4	G5	G6	G7	
110							

4W4175		Volvo Bus					
	Haldex: 72695						
	OEM: 0755247						
	Supplied With:						
	Axle Side:L			Other Side: 4W4180			
A	B	C	D	E	F		
-56	+4	37°	AP	10	14.2		
G1	G2	G3	G4	G5	G6	G7	
145							

4W4180		Volvo Bus					
	Haldex: 72696						
	OEM: 0755248						
	Supplied With:						
	Axle Side:R			Other Side: 4W4175			
A	B	C	D	E	F		
+56	+4	37°	AP	10	14.2		
G1	G2	G3	G4	G5	G6	G7	
145							

4W4185		Volvo Bus					
	Haldex: 79436						
	OEM:						
	Supplied With: K0270						
	Axle Side:			Other Side: 4W4185			
A	B	C	D	E	F		
0	0	70°	PB	14	12.9		
G1	G2	G3	G4	G5	G6	G7	
150							

TRUCK AND BUS

4W4190 **Volvo Bus**



Haldex: 79713						
OEM: 3193402						
Supplied With: K0270						
Axle Side:			Other Side: 4W4195			
A	B	C	D	E	F	
-45	0	348°	PB	10	12.9	
G1	G2	G3	G4	G5	G6	G7
145						

4W4195 **Volvo Bus**



Haldex: 79714						
OEM: 3193403						
Supplied With: K0270						
Axle Side:			Other Side: 4W4190			
A	B	C	D	E	F	
+45	0	348°	PB	10	12.9	
G1	G2	G3	G4	G5	G6	G7
145						

4W4200 **Renault**



Haldex: 79440						
OEM:						
Supplied With:						
Axle Side:			Other Side: 4W3755			
A	B	C	D	E	F	
-56	+25	351°	AP	27	14.2	
G1	G2	G3	G4	G5	G6	G7
160						

4W4205 **Dennis Bus**



Haldex: 79265						
OEM:						
Supplied With:						
Axle Side:L			Other Side: 4W4210			
A	B	C	D	E	F	
+22	0	339°	AP	10	12.9	
G1	G2	G3	G4	G5	G6	G7
140						

4W4210 **Dennis Bus**



Haldex: 79266						
OEM:						
Supplied With:						
Axle Side:R			Other Side: 4W4205			
A	B	C	D	E	F	
-22	0	339°	AP	10	12.9	
G1	G2	G3	G4	G5	G6	G7
140						

4W4215 **Foden Truck**



Haldex: 79682						
OEM:						
Supplied With:						
Axle Side:			Other Side: 4W4215			
A	B	C	D	E	F	
0	-38	355°	AP	28	14.2	
G1	G2	G3	G4	G5	G6	G7
145						

4W4235 **Hyundai Truck**



Haldex: 79778						
OEM:						
Supplied With: K0270						
Axle Side:			Other Side:			
A	B	C	D	E	F	
-60	+22.5	130°	PB	25	16.2	
G1	G2	G3	G4	G5	G6	G7
150						

4W4240 **Hyundai Truck**

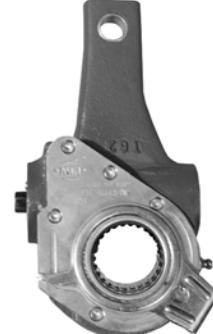

Haldex: 79779						
OEM:						
Supplied With: K0270						
Axle Side:			Other Side:			
A	B	C	D	E	F	
0	0	37°	PB	25	16.2	
G1	G2	G3	G4	G5	G6	G7
150						

TRUCK AND BUS

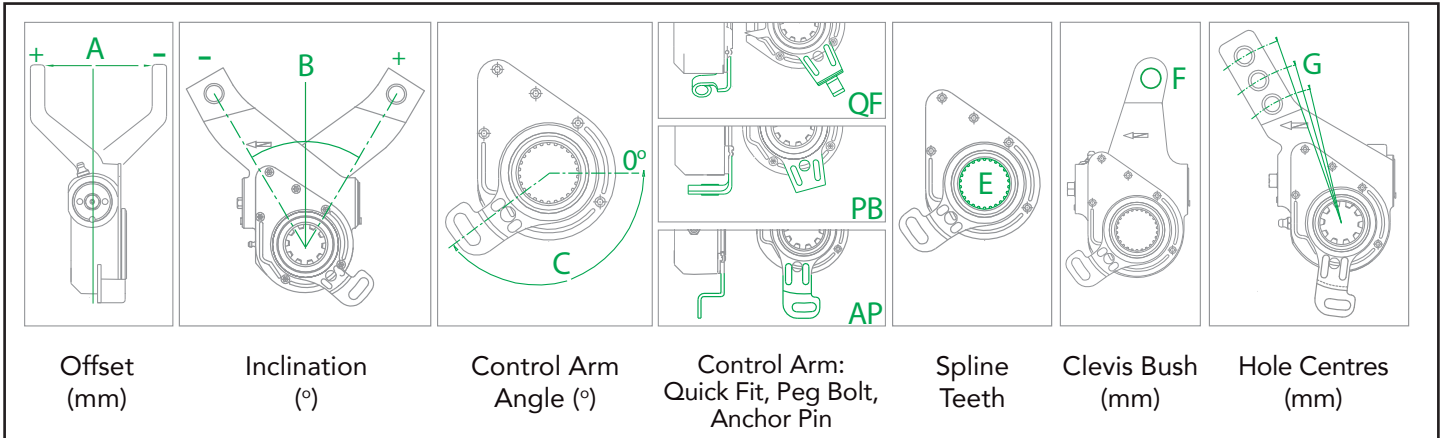

4W4245 **Hyundai Truck**



Haldex: 79780						
OEM:						
Supplied With: K0270						
Axle Side:			Other Side:			
A	B	C	D	E	F	
+60	+28	5°	PB	25	16.2	
G1	G2	G3	G4	G5	G6	G7
150						

4W4250 **Hyundai Truck**



Haldex: 79781						
OEM:						
Supplied With: K0270						
Axle Side:			Other Side:			
A	B	C	D	E	F	
+60	+28	5°	PB	25	16.2	
G1	G2	G3	G4	G5	G6	G7
150						

4W4255 **Volvo Bus**



Haldex: 79641						
OEM: 3136246						
Supplied With: K0270						
Axle Side:			Other Side: 4W4260			
A	B	C	D	E	F	
-29	0	90°	PB	10	12.9	
G1	G2	G3	G4	G5	G6	G7
185						

4W4260 **Volvo Bus**



Haldex: 79642						
OEM: 3136247						
Supplied With: K0270						
Axle Side:			Other Side: 4W4255			
A	B	C	D	E	F	
+29	0	90°	PB	10	12.9	
G1	G2	G3	G4	G5	G6	G7
185						

4W4265 **Rvi Bus**



Haldex: 79298						
OEM: 5010201995						
Supplied With:						
Axle Side:L&R			Other Side: 4W4265			
A	B	C	D	E	F	
0	0	90°	AP	28	14.2	
G1	G2	G3	G4	G5	G6	G7
160						

4W4270 **Rvi Bus**



Haldex: 79303						
OEM: 5010152965						
Supplied With:						
Axle Side:L&R			Other Side: 4W4270			
A	B	C	D	E	F	
0	0	103°	AP	27	14.2	
G1	G2	G3	G4	G5	G6	G7
190						

TRUCK AND BUS

4W4275



Haldex: 79368						
OEM:						
Supplied With:						
Axle Side:			Other Side:			
A	B	C	D	E	F	
+20	+45	124°	AP	10	16.2	
G1	G2	G3	G4	G5	G6	G7
165						

4W4280



Haldex: 79369						
OEM:						
Supplied With:						
Axle Side:			Other Side:			
A	B	C	D	E	F	
-20	+45	124°	AP	10	16.2	
G1	G2	G3	G4	G5	G6	G7
165						

4W4285



Haldex: 72872						
OEM:						
Supplied With:						
Axle Side:			Other Side:			
A	B	C	D	E	F	
0	+37	103°	AP	19	14.2	
G1	G2	G3	G4	G5	G6	G7
145						

4W4295



Haldex: 79577						
OEM:						
Supplied With:						
Axle Side:			Other Side: 4W4300			
A	B	C	D	E	F	
-75	0	120°	AP	10	14.2	
G1	G2	G3	G4	G5	G6	G7
165						

4W4305



Haldex: 72532						
OEM:						
Supplied With:						
Axle Side:			Other Side: 4W4310			
A	B	C	D	E	F	
-38	0	155°	AP	10	14.2	
G1	G2	G3	G4	G5	G6	G7
165						

4W4310



Haldex: 72533						
OEM:						
Supplied With:						
Axle Side:			Other Side: 4W4305			
A	B	C	D	E	F	
+38	0	155°	AP	10	14.2	
G1	G2	G3	G4	G5	G6	G7
165						

4W4315

Sisu Truck



Haldex: 79407						
OEM:						
Supplied With:						
Axle Side:			Other Side: 4W4320			
A	B	C	D	E	F	
-56	+25	122°	AP	26	14.2	
G1	G2	G3	G4	G5	G6	G7
165						

4W4320

Sisu Truck



Haldex: 79408						
OEM:						
Supplied With:						
Axle Side:			Other Side: 4W4315			
A	B	C	D	E	F	
+56	+25	122°	AP	26	14.2	
G1	G2	G3	G4	G5	G6	G7
165						

TRUCK AND BUS

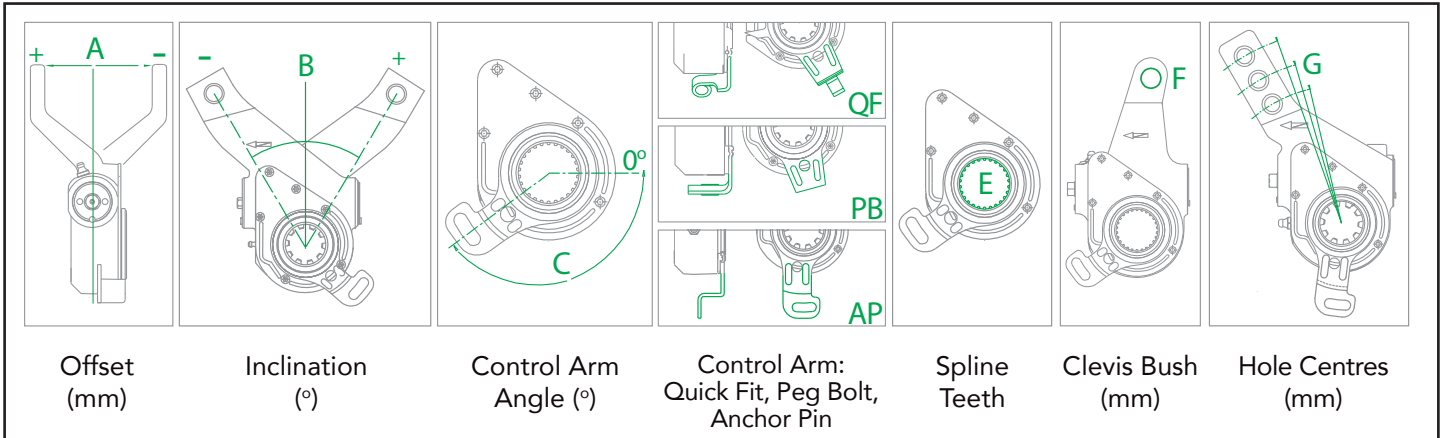

4W4350		Saurer Truck					
	Haldex: 70764						
	OEM:						
	Supplied With:						
	Axle Side:L&R			Other Side: 4W4350			
	A	B	C	D	E	F	
0	0	0°	AP	19	14.2		
G1	G2	G3	G4	G5	G6	G7	
135	180						

4W4355		Leyland Bus					
	Haldex: 72559						
	OEM:						
	Supplied With: K0270						
	Axle Side:L			Other Side: 4W4360			
	A	B	C	D	E	F	
-48	+22.5	130°	PB	10	12.9		
G1	G2	G3	G4	G5	G6	G7	
152							

4W4360		Leyland Bus					
	Haldex: 72560						
	OEM:						
	Supplied With: K0270						
	Axle Side:R			Other Side: 4W4355			
	A	B	C	D	E	F	
+48	+22.5	130°	PB	10	12.9		
G1	G2	G3	G4	G5	G6	G7	
152							

4W4365		Dennis Bus					
	Haldex: 72563						
	OEM:						
	Supplied With: K0270						
	Axle Side:L&R			Other Side: 4W4365			
	A	B	C	D	E	F	
0	0	0°	PB	10	12.9		
G1	G2	G3	G4	G5	G6	G7	
180							

4W4380		Sisu Truck					
	Haldex: 79002						
	OEM:						
	Supplied With:						
	Axle Side:			Other Side: 4W4385			
	A	B	C	D	E	F	
-56	+4	355°	AP	26	14.2		
G1	G2	G3	G4	G5	G6	G7	
145							

4W4385		Sisu Truck					
	Haldex: 79003						
	OEM:						
	Supplied With:						
	Axle Side:			Other Side: 4W4380			
	A	B	C	D	E	F	
+56	+4	355°	AP	26	14.2		
G1	G2	G3	G4	G5	G6	G7	
145							

TRUCK AND BUS

4W4390

Sisu Truck



Haldex: 72937						
OEM:						
Supplied With:						
Axle Side:			Other Side: 4W4395			
A	B	C	D	E	F	
-56	+4	100°	AP	26	14.2	
G1	G2	G3	G4	G5	G6	G7
145						

4W4395

Sisu Truck



Haldex: 72938						
OEM:						
Supplied With:						
Axle Side:			Other Side: 4W4390			
A	B	C	D	E	F	
+56	+4	100°	AP	26	14.2	
G1	G2	G3	G4	G5	G6	G7
145						

4W4415

Mercedes Bus



Haldex: 79637						
OEM: 0003520940						
Supplied With:						
Axle Side:			Other Side: 4W4420			
A	B	C	D	E	F	
-45	+30	50°	AP	19	14.2	
G1	G2	G3	G4	G5	G6	G7
145						

4W4420

Mercedes Bus



Haldex: 79638						
OEM: 0003520840						
Supplied With:						
Axle Side:			Other Side: 4W4415			
A	B	C	D	E	F	
+45	+30	50°	AP	19	14.2	
G1	G2	G3	G4	G5	G6	G7
145						

4W4425

Man Truck and Bus



Haldex: 79725						
OEM: 81506106246						
Supplied With:						
Axle Side:R			Other Side: 4W4430			
A	B	C	D	E	F	
-37	+34	339°	AP	26	14.2	
G1	G2	G3	G4	G5	G6	G7
145						

4W4430

Man Truck and Bus



Haldex: 79726						
OEM: 81506106247						
Supplied With:						
Axle Side:L			Other Side: 4W4425			
A	B	C	D	E	F	
+37	+34	339°	AP	26	14.2	
G1	G2	G3	G4	G5	G6	G7
145						

4W4435



Haldex: 72867						
OEM: 5801112932						
Supplied With:						
Axle Side:L			Other Side: 4W4440			
A	B	C	D	E	F	
+60	+22.5	142°	AP	26	14.2	
G1	G2	G3	G4	G5	G6	G7
160						

4W4440



Haldex: 72868						
OEM: 5801112933						
Supplied With:						
Axle Side:R			Other Side: 4W4435			
A	B	C	D	E	F	
-60	+22.5	142°	AP	26	14.2	
G1	G2	G3	G4	G5	G6	G7
160						

TRUCK AND BUS

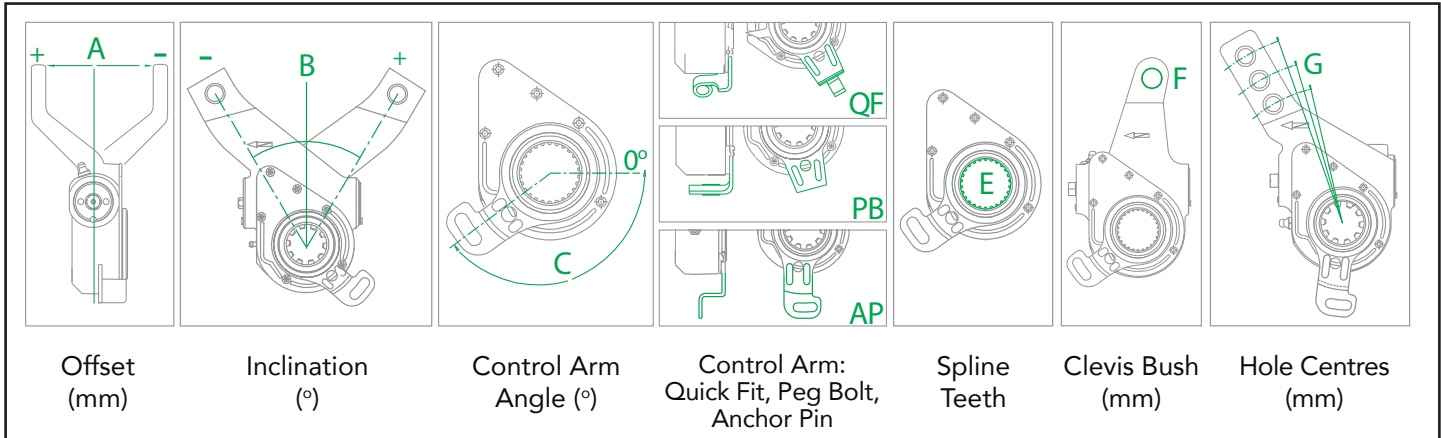

4W4445



Haldex: 79520						
OEM: 5801108076						
Supplied With:						
Axle Side:			Other Side: 4W4450			
A	B	C	D	E	F	
-29	0	71°	AP	26	14.2	
G1	G2	G3	G4	G5	G6	G7
150						

4W4450



Haldex: 79521						
OEM: 5801108078						
Supplied With:						
Axle Side:			Other Side: 4W4445			
A	B	C	D	E	F	
+29	0	71°	AP	26	14.2	
G1	G2	G3	G4	G5	G6	G7
150						

4W4455 Man Bus



Haldex: 79772						
OEM: 81506106250						
Supplied With:						
Axle Side:			Other Side: 4W4455			
A	B	C	D	E	F	
0	+37	106°	AP	26	14.2	
G1	G2	G3	G4	G5	G6	G7
130						

4W4460 Renault Truck



Haldex: 79683						
OEM:						
Supplied With:						
Axle Side:			Other Side: 4W4465			
A	B	C	D	E	F	
-38	0	350°	AP	27	14.2	
G1	G2	G3	G4	G5	G6	G7
160						

4W4465 Renault Truck



Haldex: 79684						
OEM:						
Supplied With:						
Axle Side:			Other Side: 4W4460			
A	B	C	D	E	F	
+38	0	350°	AP	27	14.2	
G1	G2	G3	G4	G5	G6	G7
160						

4W4470 Man Truck



Haldex: 79694						
OEM: 81506106224						
Supplied With:						
Axle Side:			Other Side: 4W4475			
A	B	C	D	E	F	
-35	-29	339°	AP	26	14.2	
G1	G2	G3	G4	G5	G6	G7
190						

TRUCK AND BUS

4W4475 **Man Truck**



Haldex: 79693						
OEM: 81506106225						
Supplied With:						
Axle Side:			Other Side: 4W4470			
A	B	C	D	E	F	
+35	-29	339°	AP	26	14.2	
G1	G2	G3	G4	G5	G6	G7
190						

4W4480 **Scania Truck**



Haldex: 79550						
OEM: 1789566						
Supplied With:						
Axle Side:			Other Side: 4W4485			
A	B	C	D	E	F	
-65	0	140°	AP	10	16.2	
G1	G2	G3	G4	G5	G6	G7
165						

4W4485 **Scania Truck**

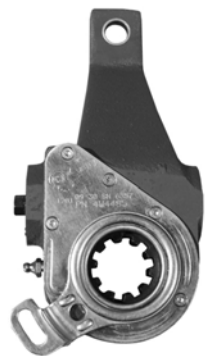

Haldex: 79551						
OEM: 1789565						
Supplied With:						
Axle Side:			Other Side: 4W4480			
A	B	C	D	E	F	
+65	0	140°	AP	10	16.2	
G1	G2	G3	G4	G5	G6	G7
165						

4W4490 **Renault Truck**



Haldex: 79535						
OEM: 5430053192						
Supplied With:						
Axle Side:L			Other Side: 4W4495			
A	B	C	D	E	F	
+38	+30	154°	AP	27	14.2	
G1	G2	G3	G4	G5	G6	G7
160						

4W4495 **Renault Truck**



Haldex: 79536						
OEM: 5430053193						
Supplied With:						
Axle Side:R			Other Side: 4W4490			
A	B	C	D	E	F	
-38	+30	154°	AP	27	14.2	
G1	G2	G3	G4	G5	G6	G7
160						

6Y6500 **Mercedes Truck**



Haldex: 80000						
OEM: 9454200238						
Supplied With:						
Axle Side:L			Other Side: 6Y6505			
A	B	C	D	E	F	
-56	+15		AP	26	14.2	
G1	G2	G3	G4	G5	G6	G7
145						

6Y6505 **Mercedes Truck**



Haldex: 80001						
OEM: 9454200338						
Supplied With:						
Axle Side:R			Other Side: 6Y6500			
A	B	C	D	E	F	
+56	+15		AP	26	14.2	
G1	G2	G3	G4	G5	G6	G7
145						

6Y6510 **Mercedes Truck**



Haldex: 80008						
OEM: 9454200038						
Supplied With:						
Axle Side:L			Other Side: 6Y6515			
A	B	C	D	E	F	
+37	+34		AP	26	14.2	
G1	G2	G3	G4	G5	G6	G7
145						

TRUCK AND BUS

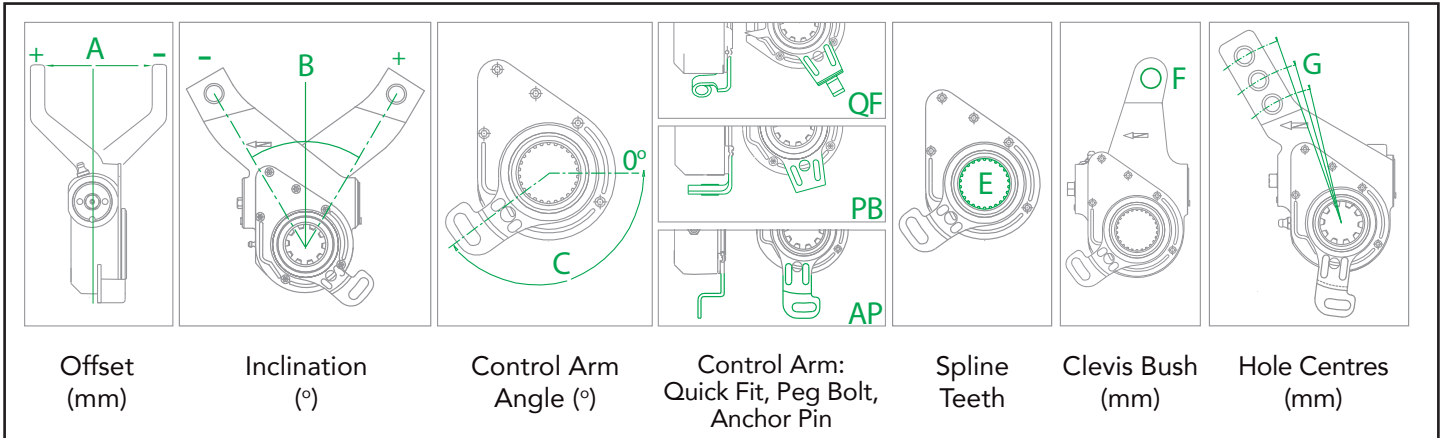

6Y6515 Mercedes Truck



Haldex: 80009						
OEM: 9454200138						
Supplied With:						
Axle Side:R			Other Side: 6Y6510			
A	B	C	D	E	F	
-37	+34		AP	26	14.2	
G1	G2	G3	G4	G5	G6	G7
145						

6Y6520 Mercedes Truck



Haldex: 80010						
OEM: 9454200838						
Supplied With:						
Axle Side:L			Other Side: 6Y6525			
A	B	C	D	E	F	
-56	-5		AP	26	14.2	
G1	G2	G3	G4	G5	G6	G7
145						

6Y6525 Mercedes Truck



Haldex: 80011						
OEM: 9454200738						
Supplied With:						
Axle Side:R			Other Side: 6Y6520			
A	B	C	D	E	F	
+56	-5		AP	26	14.2	
G1	G2	G3	G4	G5	G6	G7
145						

6Y6530 Mercedes Truck



Haldex: 80012						
OEM: 9454200538						
Supplied With:						
Axle Side:L			Other Side: 6Y6535			
A	B	C	D	E	F	
-42	+105		AP	26	14.2	
G1	G2	G3	G4	G5	G6	G7
145						

6Y6535 Mercedes Truck



Haldex: 80013						
OEM: 9454200638						
Supplied With:						
Axle Side:R			Other Side: 6Y6530			
A	B	C	D	E	F	
+42	+105		AP	26	14.2	
G1	G2	G3	G4	G5	G6	G7
145						

6Y6540 Mercedes Truck



Haldex: 80014						
OEM: 9454200438						
Supplied With:						
Axle Side:R			Other Side: 6Y6545			
A	B	C	D	E	F	
+56	+15		AP	26	14.2	
G1	G2	G3	G4	G5	G6	G7
145						

TRUCK AND BUS

6Y6545

Mercedes Truck



Haldex: 80030						
OEM: 9454200938						
Supplied With:						
Axle Side:L			Other Side: 6Y6540			
A	B	C	D	E	F	
-56	+15		AP	26	14.2	
G1	G2	G3	G4	G5	G6	G7
145						

6Y6600



Haldex: 80133						
OEM:						
Supplied With:						
Axle Side:			Other Side:			
A	B	C	D	E	F	
0	+20		AP	10	14.2	
G1	G2	G3	G4	G5	G6	G7
130						

6Y6620

Man Truck



Haldex: 80176						
OEM: 81506106263						
Supplied With:						
Axle Side:L			Other Side: 6Y6720			
A	B	C	D	E	F	
-56	+15		AP	26	14.2	
G1	G2	G3	G4	G5	G6	G7
145						

6Y6625

Man Truck



Haldex: 80183						
OEM: 81506106266						
Supplied With:						
Axle Side:R			Other Side:			
A	B	C	D	E	F	
+56	+15		AP	26	14.2	
G1	G2	G3	G4	G5	G6	G7
145						

6Y6630

Man Truck



Haldex: 80180						
OEM: 81506106261						
Supplied With:						
Axle Side:L			Other Side: 6Y6660			
A	B	C	D	E	F	
-56	-5		AP	26	14.2	
G1	G2	G3	G4	G5	G6	G7
145						

6Y6660

Man Truck



Haldex: 80181						
OEM: 81506106262						
Supplied With:						
Axle Side:R			Other Side: 6Y6630			
A	B	C	D	E	F	
+56	-5		AP	26	14.2	
G1	G2	G3	G4	G5	G6	G7
145						

6Y6720

Man Truck



Haldex: 80177						
OEM: 81506106264						
Supplied With:						
Axle Side:R			Other Side: 6Y6620			
A	B	C	D	E	F	
+56	+15		AP	26	14.2	
G1	G2	G3	G4	G5	G6	G7
145						

6Y6725

Man Truck



Haldex: 80178						
OEM: 81506106259						
Supplied With:						
Axle Side:L			Other Side: 6Y6730			
A	B	C	D	E	F	
+37	+34		AP	26	14.2	
G1	G2	G3	G4	G5	G6	G7
145						

TRUCK AND BUS

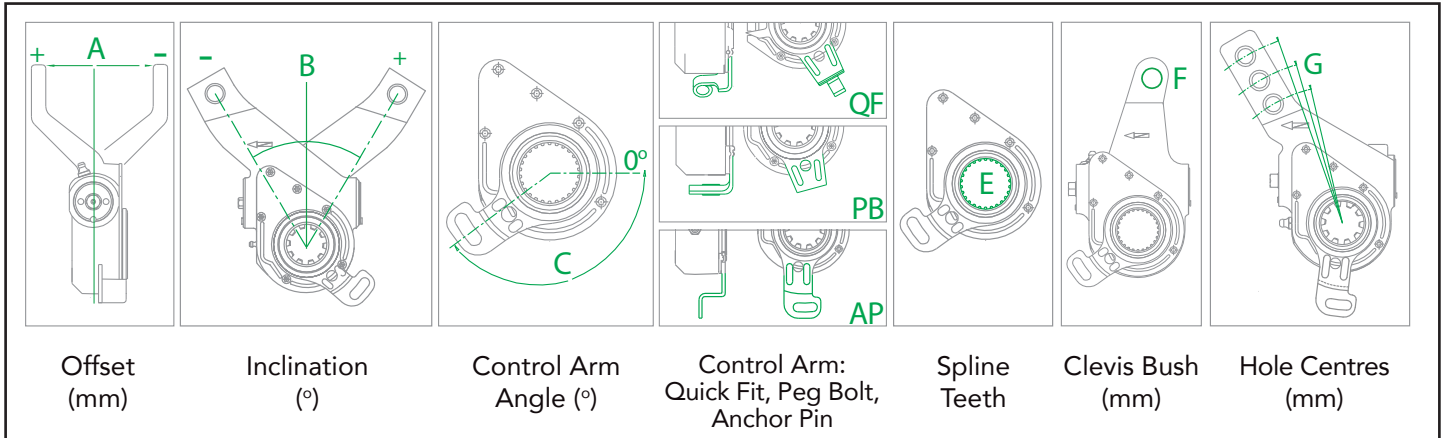

6Y6730		Man Truck					
	Haldex: 80179						
	OEM: 81506106260						
	Supplied With:						
	Axle Side:R			Other Side: 6Y6725			
	A	B	C	D	E	F	
-37	+34		AP	26	14.2		
G1	G2	G3	G4	G5	G6	G7	
145							

EXTENDED RANGE

1

2

MEI produces a full range of Automatic and Self-setting Automatic Slack Adjusters for North American applications.

3

4

5

6

7

8

9

10

11

12

13

14

15

16

17

18

19

20

21

22

23

24

25

26

27

28

29

30

31

32

33

34

35

36

37

38

39

40

41

42

43

44

45

46

47

48

49

50

51

52

53

54

55

56

57

58

59

60

61

62

63

64

65

66

67

68

69

70

71

72

73

74

75

76

77

78

79

80

81

82

83

84

85

86

87

88

89

90

91

92

93

94

95

96

97

98

99

100

MEI produces a full range of Manual Slack Adjusters In the DeWe Brand.

KITS & ACCESSORIES

K1000



K1020

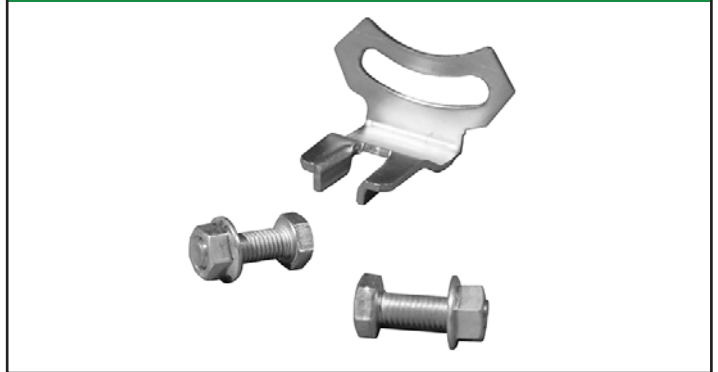

K1030



K1530



K1605



K8000



K8010



K8040



KITS & ACCESSORIES

K8060



K8080



K8090



K8100



K0900



K0910



K0200

K0270



K0300

K0310

K0320



12.9 mm

14 mm

16 mm

FITTING INSTRUCTIONS

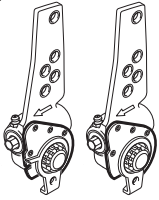

ASA



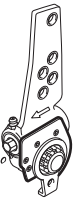

S-ASA



Installation instructions are common to ASA (Automatic Slack Adjuster) and S-ASA (Self-setting Automatic Slack Adjuster).

Do not use air wrenches or hammers. Their use will damage the product, prevent correct function and will void the warranty.

1

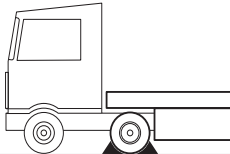
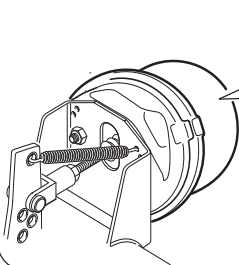

+ Min 6 Bar

Text in green is offered as advice.

If you have any questions about the fitting instructions, or require further advice, please email technical@meibrakes.com

1. Ensure the vehicle is securely chocked before releasing the parking brake. Cage the spring brake or use a minimum hold off pressure of 90 psi (6 bar).

2

A



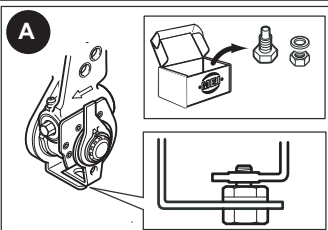

B

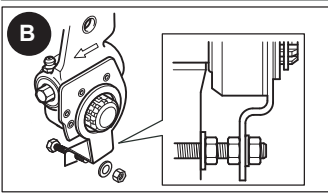

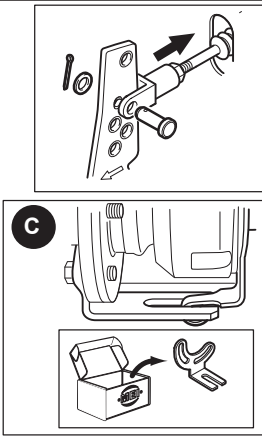
C

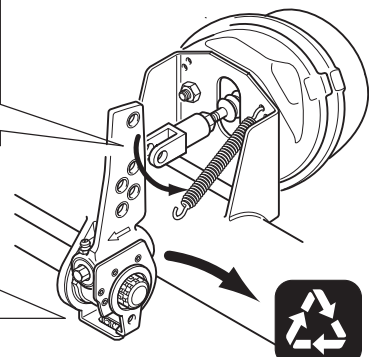



2. Remove the old slack adjuster, clevis pin, washer and split pins. Replace used parts with the new ones provided.

2a. Always replace Peg Bolt with the new one provided.

2b. Inspect Anchor Pins and replace if worn or damaged.

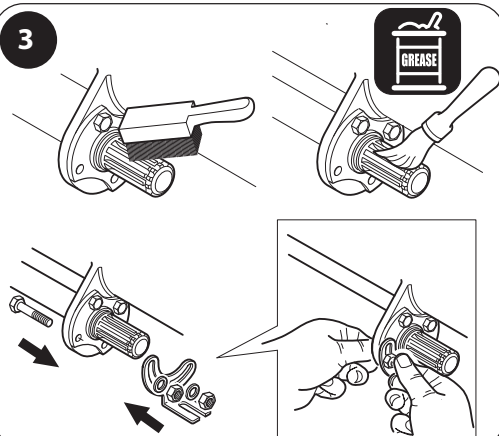

2c. Always replace Anchor Bracket with the new one provided.

3



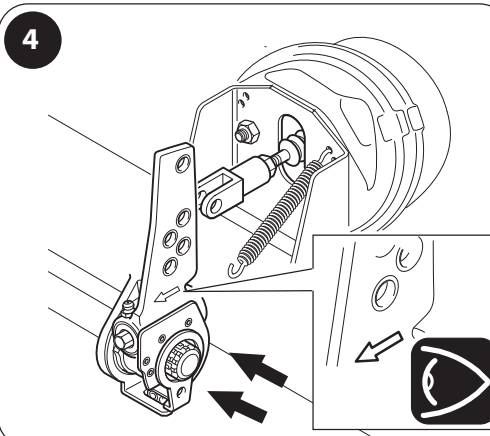

3. Clean and grease cam splines. Fit the anchor point by hand prior to final set up.

4

4. Slide the slack adjuster on to the cam spline, locating the control arm in the anchor point at the same time.

 'The adjuster only works in the direction of the cast arrow on the housing'

FITTING INSTRUCTIONS

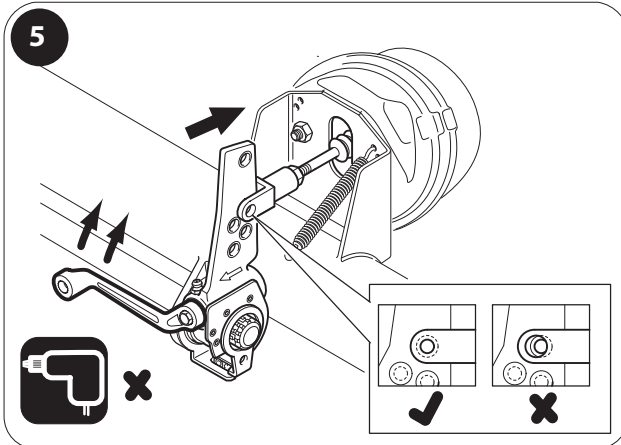

5. Using a socket wrench wind in the adjuster so that the clevis hole on the adjuster lines up with the clevis on the actuator.

😊 'Do not pull the push rod to fit the pin. If required, de-adjust and start again, ensuring the clevis hole and clevis line up'

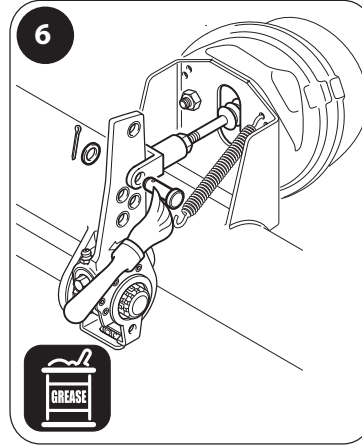

6. Grease the clevis pin before fitting. The clevis pin should slide into the holes without effort.

😊 'If necessary, slacken off the lock nut on the clevis to achieve an easy fit and re-tighten afterwards'

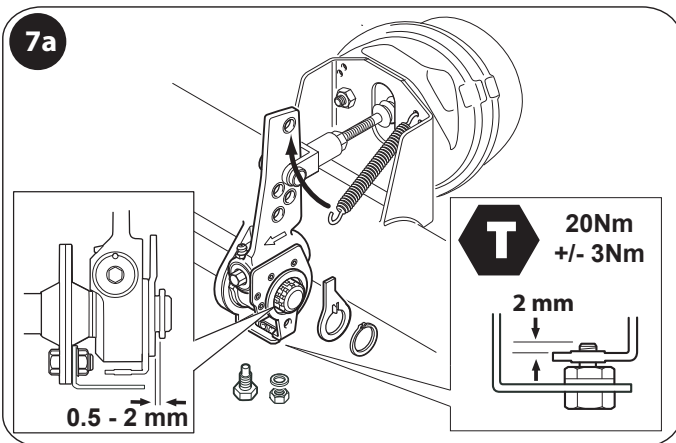

7a. Fit wear indicator and return spring where present. Fit shim washers to ensure the gap prescribed. When fitting Peg Bolts ensure they protrude through the control arm grommet and tighten as prescribed.

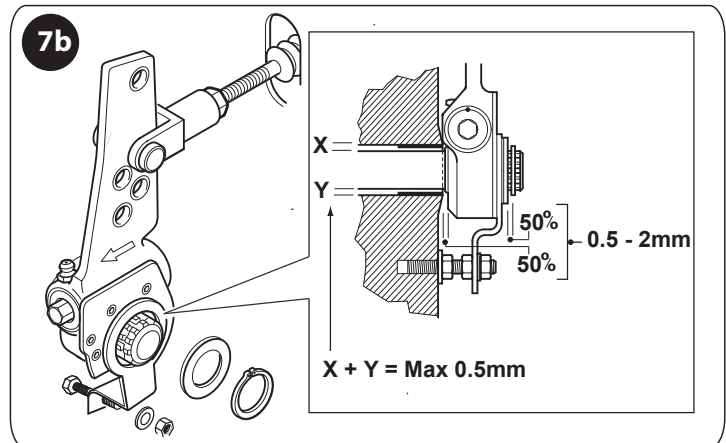

7b. Replace cam bearings where there is excessive movement – the maximum allowable is 0.5mm.

😊 'More movement will weaken the control arm or anchor points, disabling the adjustment'

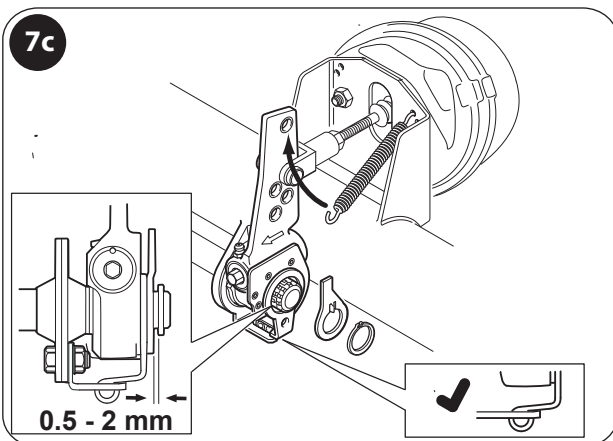

7c. The control arm should always locate fully in the anchor bracket slot.

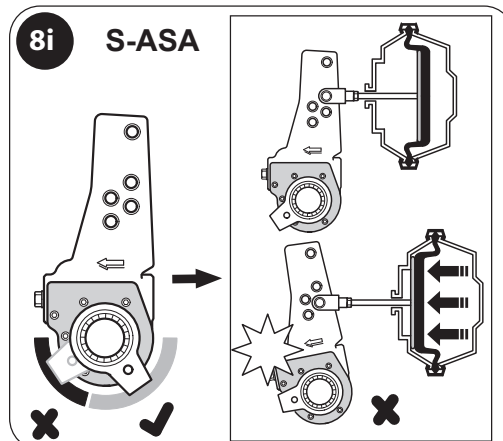

8i. When installing S-ASA the control arm and anchor point must allow free and full articulation of the adjuster.

😊 'Incorrect installation can lead to clashing with surrounding chassis or components'

FITTING INSTRUCTIONS

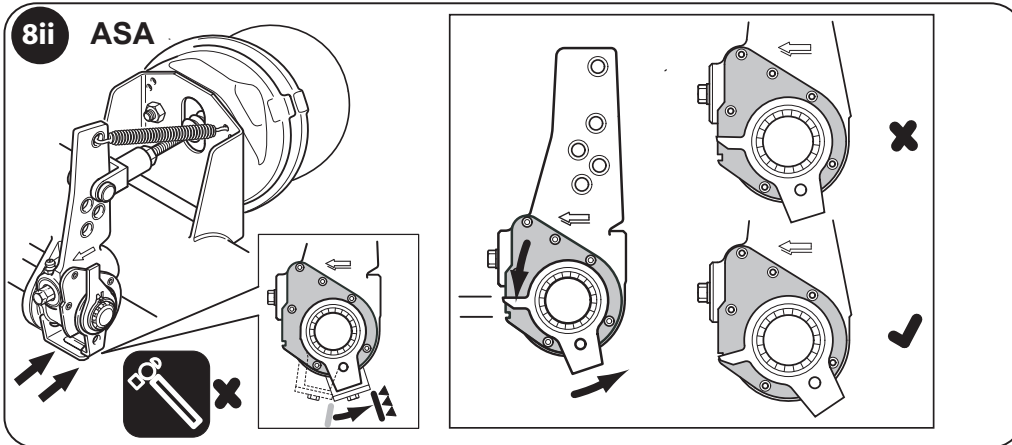

8ii. When installing ASA the control arm and anchor point must be set in the correct position, as indicated by the arrow on the control arm. This is in the same rotational direction as the arrow on the housing.

☺ 'This ensures the correct running clearance is maintained by the ASA'

On some ASA a setting indicator and notch on the control plate are provided as a visual aid. The setting indicator should line up with the notch when correctly installed.

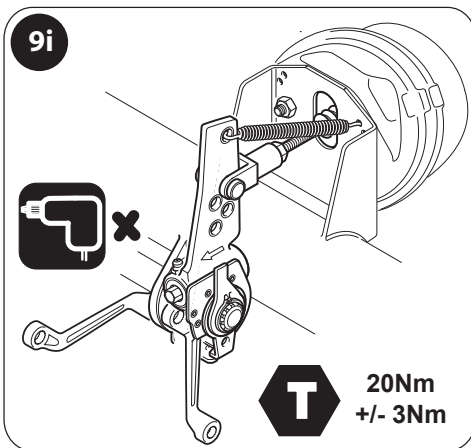

9i. Once the installation is complete, anchor points should be tightened using the prescribed torque.

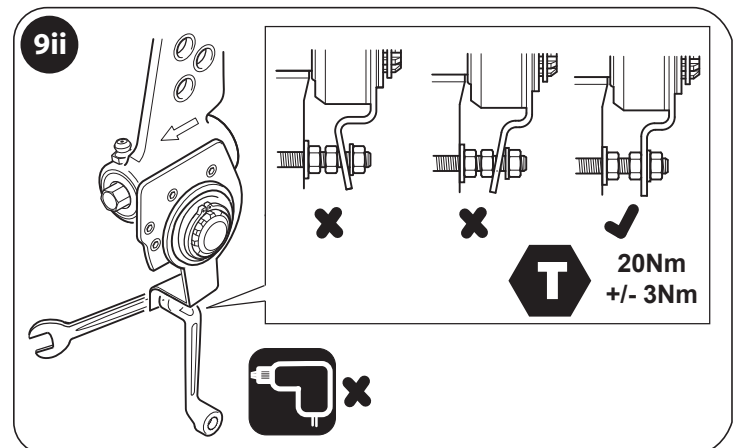

9ii. Control arm must not be bent during tightening of the anchor pin.

☺ 'There should be no stress on any fixing point or clevis. Stress on the anchor points can cause fatigue and eventual fracture, disabling correct function'

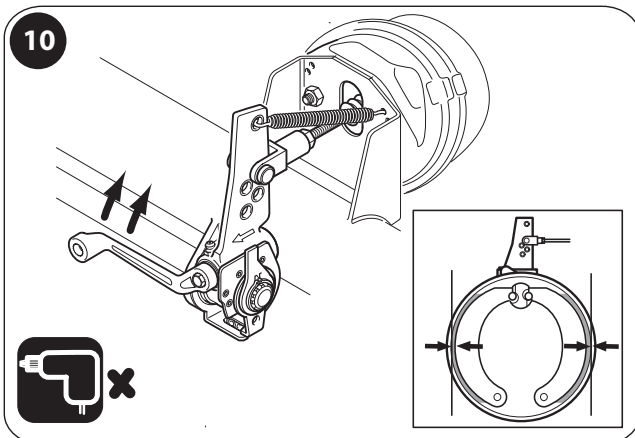

10. Manually adjust the brake by putting a socket wrench on to the hex nut and turning until the brake linings touch the brake drum.

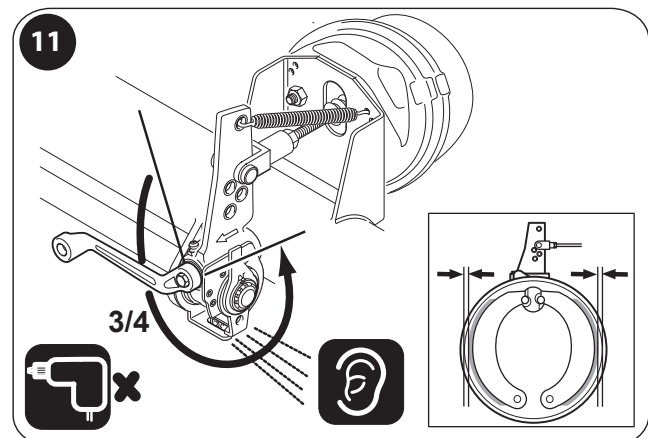

11. De-adjust the brake by turning the socket wrench in the opposite direction by $\frac{3}{4}$ of a turn.

☺ 'You should hear a clicking noise'

FITTING INSTRUCTIONS

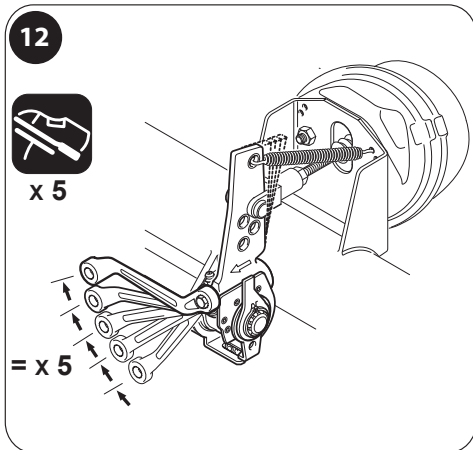

12. Apply and release the service brake. The hexagon should index clockwise on the release stroke.

☺ 'This is best seen by leaving a wrench or socket mounted indicator on the hex nut'

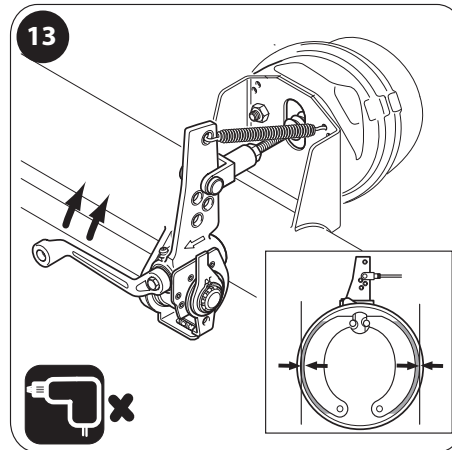

13. The function test now complete, re-set the brake by putting a socket wrench on to the hex nut and turning until the brake linings touch the brake drum.

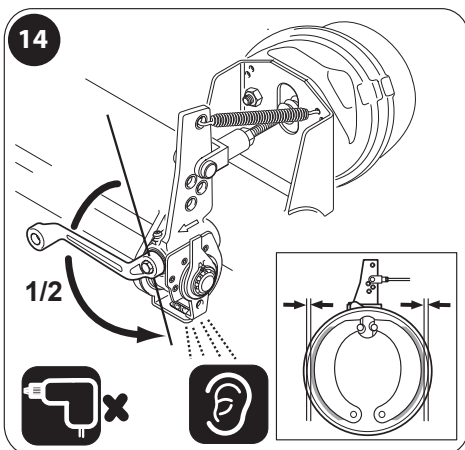

14. De-adjust the brake by turning the socket wrench in the opposite direction by $\frac{1}{2}$ a turn.

☺ 'This allows the brake drum to rotate freely'

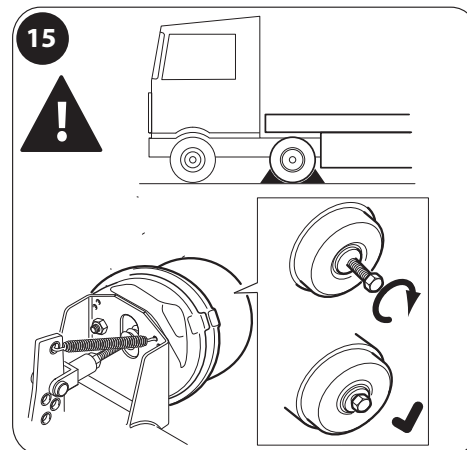

15. Uncage the spring brake and apply the parking brake prior to removing the chocks from the vehicle.

For a full list of fitting and maintenance instructions please visit our website.

MAINTENANCE

Always ensure the vehicle is securely chocked before releasing the parking brake. Cage the spring brake or use a minimum hold off pressure of 90 psi (6 bar).

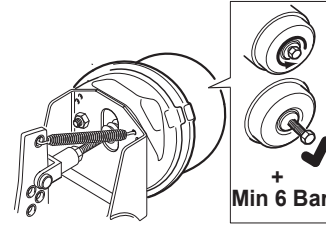
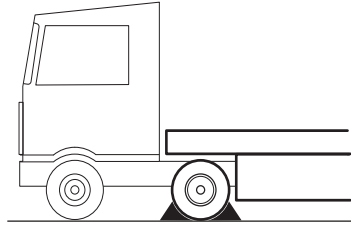

REGULAR CHECK

Automatic Slack Adjusters should maintain a constant stroke of the actuator. At regular service intervals, appropriate to the application, the following checks should be made:

Apply the brake. Observe the stroke length of the actuator.

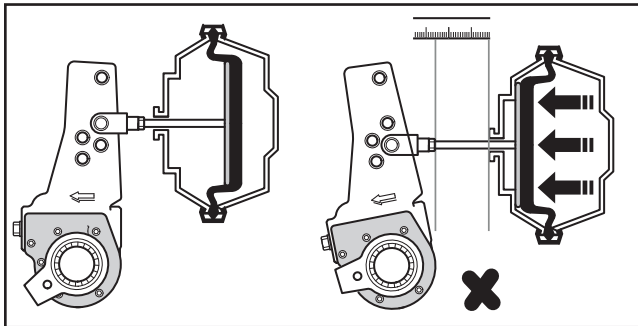

The stroke should not exceed 2/3 of the maximum stroke of the actuator. If the stroke is more than 2/3 of maximum stroke, carry out the annual check.

Examine the foundation brake system for seized brake shoes and cam rollers. If no other causes of excess stroke are found, replace the slack adjuster.



Check the anchor point and the condition of the control arm. If the anchor point is loose, re-fit it.

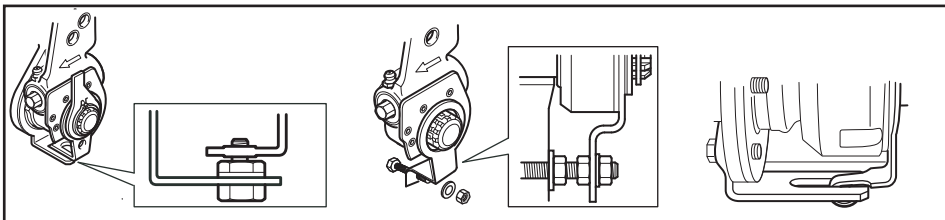

If the control arm is bent or cracked replace the slack adjuster.

Check the condition of the camshaft journal and bush. If there is more than 0.5mm gap replace the camshaft and bush.

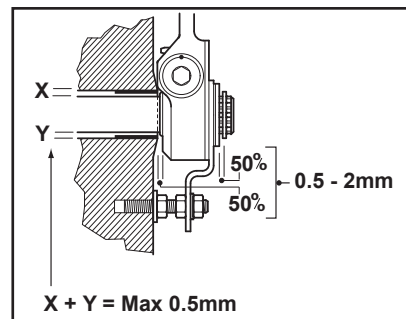
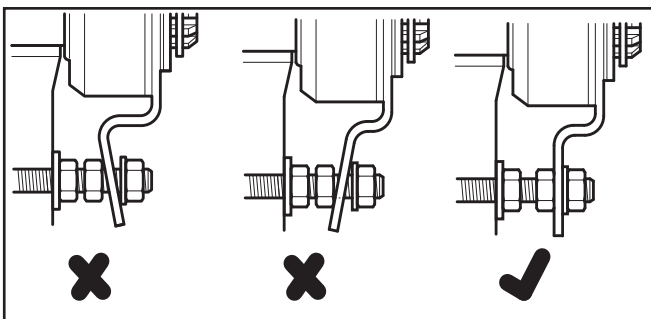

MEI Automatic and Self-setting Automatic Slack Adjusters should be lubricated every 10,000 km.

MAINTENANCE

ANNUAL CHECK

The following check should be made annually for truck and trailer applications. For city bus applications it should be carried out every quarter.

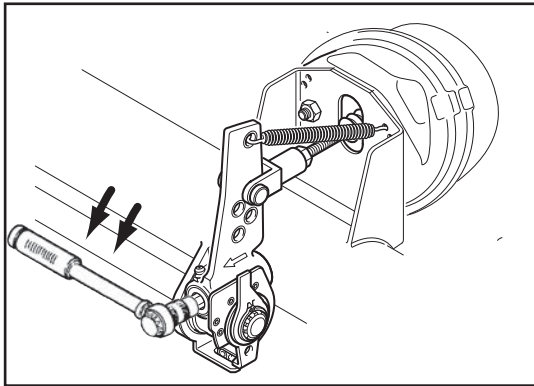

Using a torque wrench, rotate the hex nut in anti-clockwise direction:



There should be an audible clicking sound.

Repeat the operation to ensure the clutch is engaged.

The torque required to turn the hex nut must be 18Nm.



If there is no clicking sound or the torque required is less than 18Nm replace the slack adjuster.

Using a socket wrench or socket mounted indicator, rotate the hex nut 270° in anti-clockwise direction.

Apply the brake 5 times.

The wrench or indicator will move in a clockwise direction on each application of the brake.

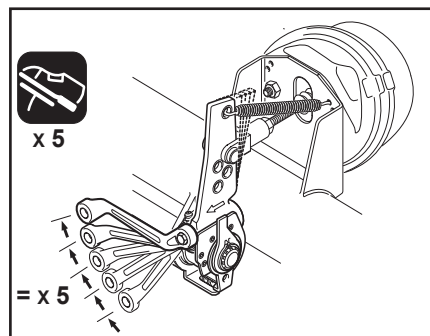
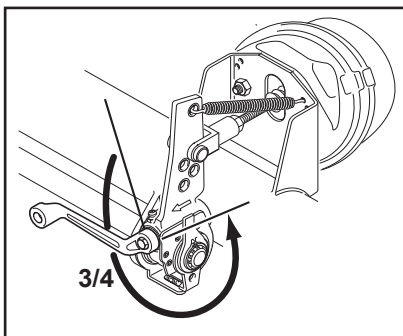

If the wrench or indicator does not move replace the slack adjuster.



After any service or maintenance, always reset the brake:

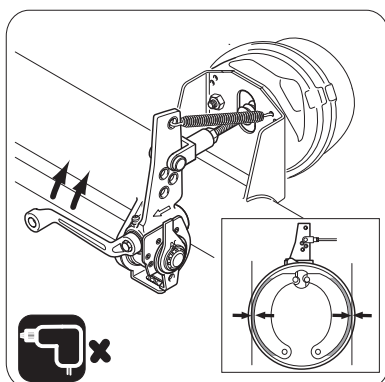

Re-set the brake by putting a socket wrench on to the hex nut and turning until the brake linings touch the brake drum.

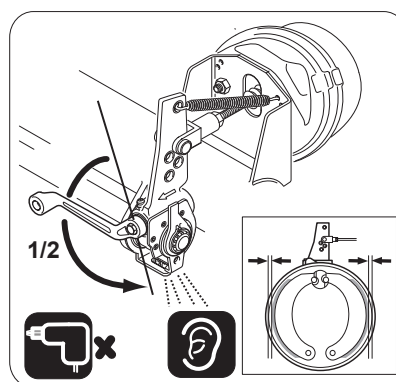

De-adjust the brake by turning the socket wrench in the opposite direction by 1/2 a turn.

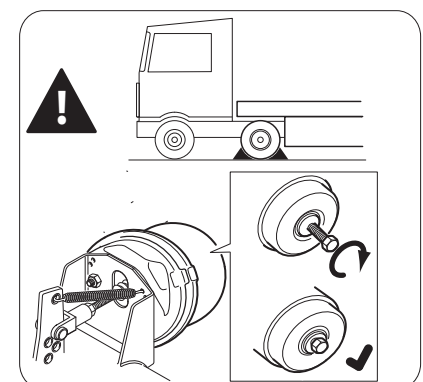

Uncage the spring brake and apply the parking brake prior to removing the chocks from the vehicle.

Note that MEI Automatic and Self-setting Automatic Slack Adjusters cannot compensate for other defects within the braking system. Worn or missing return springs, loose wheel bearings, defective actuators, worn camshaft journals, camshaft bushes or camshaft rollers and worn anchor pins must all be rectified for the brake system to function properly.



WARRANTY



MEI warrants that MEI Automatic Slack Adjusters and Self-setting Automatic Slack Adjusters, when installed and maintained on vehicles in accordance with MEI Installation and Maintenance instructions, will be free of defect in material or workmanship under normal use and service for the period and distance indicated:

Truck and Trailer on highway	3 years	300,000km
Truck and Trailer off highway	1 year	100,000km
City Bus	1 year	100,000km

Warranty period is from Date of Manufacture, as indicated on the cover plate:

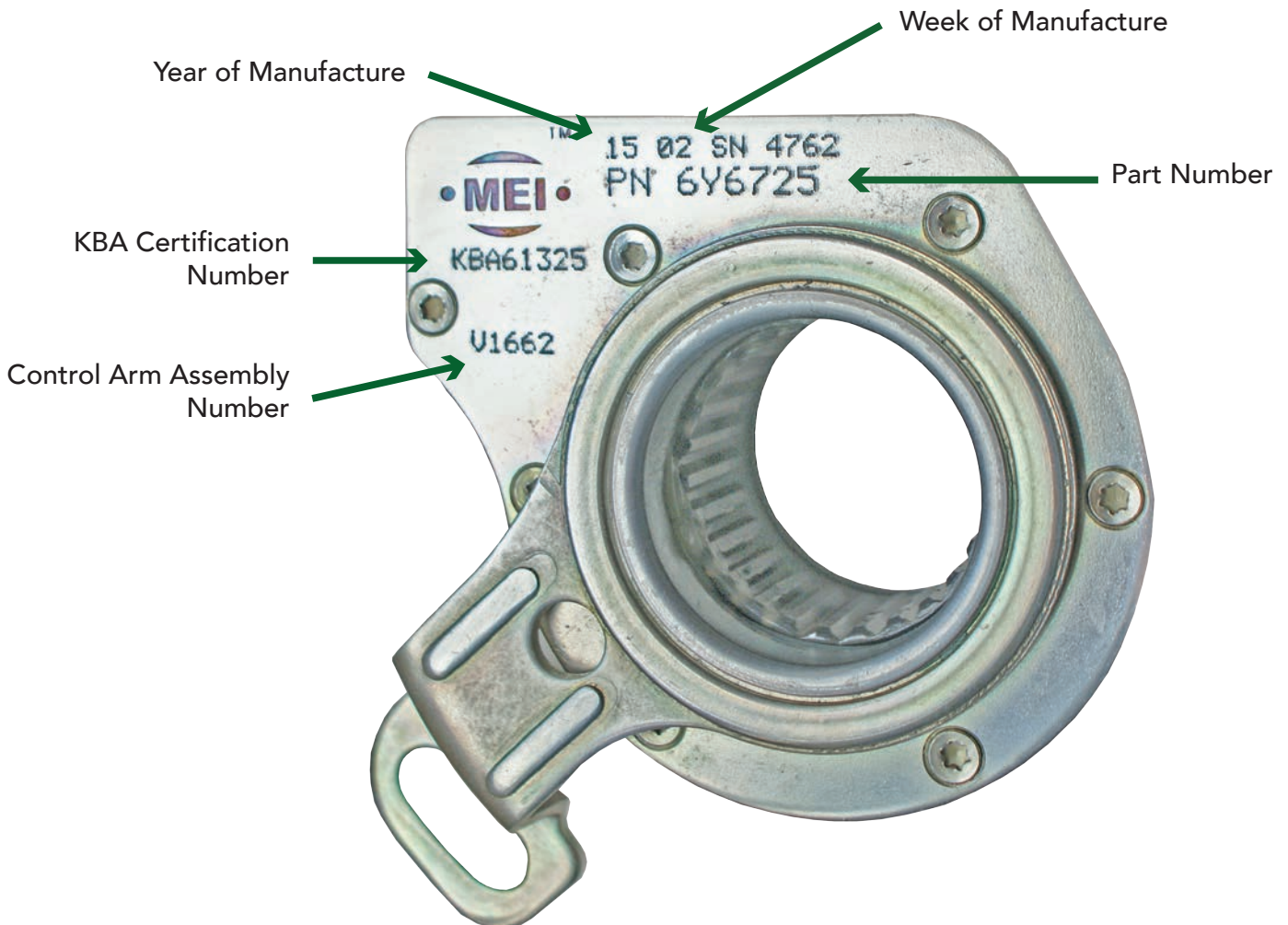

WARRANTY



Automatic and Self-setting Automatic Slack Adjusters cannot compensate for other deficiencies in the brake system. Before returning please check for:

- Correct Installation
- Regular Maintenance
- Loose Wheel Bearings
- Worn Cam Bushes and Cam bearings
- Defective Brake Chambers
- Missing or worn Return Springs

All claims must be made within the warranty period. The MEI slack adjuster must be returned for examination, together with detail of the fault found, distance in service and application.

MEI warranty does not cover parts which fail due to incorrect installation or abuse. MEI does not accept liability for any consequential losses arising from the failure of the unit.





CROSS REFERENCE

HALDEX - MEI

HALDEX	MEI	PAGE	HALDEX	MEI	PAGE	HALDEX	MEI	PAGE
11011	4W3405	68	70894	4W2700	48	72062	4W2165	32
12254	4W2405	39	70903	4W3495	70	72063	4W2145	32
12255	4W2410	39	70905	4W2460	41	72064	4W3890	81
12256	4W2415	39	70906	4W2465	41	72065	4W3895	81
70510	4W2650	46	70917	4W2840	52	72069	4W2950	55
70511	4W2655	46	70918	4W2470	41	72070	4W2830	51
70512	4W2365	38	70919	4W3385	67	72085	4W3500	71
70530	4W2835	51	70923	4W2540	43	72103	4W1175	16
70532	4W2430	40	70924	4W2545	43	72104	4W1165	16
70542	4W4115	87	70930	4W3170	61	72105	4W2495	42
70543	4W4120	87	70931	4W2970	55	72106	4W2500	42
70582	4W2390	39	70943	4W2475	41	72145	4W2985	56
70583	4W2355	38	70944	4W2480	41	72173	4W2160	32
70624	4W2330	37	70945	4W2315	37	72174	4W2155	32
70626	4W2320	37	70949	4W1080	14	72177	4W2845	52
70627	4W2435	40	70952	4W2065	29	72178	4W3480	70
70634	4W2370	38	70953	4W2060	29	72179	4W3775	78
70706	4W2440	40	70954	4W2045	29	72180	4W2235	34
70720	4W2965	55	70969	4W1215	17	72181	4W2170	33
70753	4W2445	40	70970	4W1220	17	72199	4W2175	33
70754	4W2765	49	70975	4W4125	87	72203	4W2505	42
70762	4W2770	50	70976	4W4130	87	72204	4W2510	42
70764	4W4350	92	70977	4W2485	41	72211	4W2715	48
70771	4W3130	60	70978	4W2490	42	72212	4W2720	48
70772	4W3125	60	70986	4W2825	51	72213	4W2130	31
70775	4W2100	31	70987	4W3390	67	72234	4W2855	52
70785	4W2890	53	70988	4W3395	67	72235	4W2990	56
70786	4W2895	53	70990	4W3285	64	72238	4W1160	16
70802	4W1115	15	70991	4W3290	65	72239	4W1110	15
70803	4W1120	15	72014	4W3255	63	72250	4W1075	14
70809	4W3160	61	72015	4W3260	64	72253	4W1105	14
70810	4W2745	49	72033	4W3475	70	72255	4W1150	16
70823	4W2000	28	72034	4W3470	70	72256	4W1065	13
70824	4W2805	51	72035	4W3465	69	72261	4W1055	13
70825	4W2810	51	72036	4W2135	31	72266	4W1050	13
70832	4W2450	41	72037	4W2140	32	72268	4W1060	13
70833	4W2455	41	72038	4W2750	49	72282	4W1100	14
70859	4W2325	37	72039	4W2755	49	72326	4W2860	52
70867	4W2150	32	72040	4W3145	60	72329	4W3435	69
70869	4W3780	78	72041	4W3150	61	72330	4W2960	55
70870	4W4170	88	72054	4W3795	79	72333	4W3100	59
70871	4W2005	28	72055	4W3800	79	72357	4W3670	75
70891	4W3060	58	72059	4W2040	29	72358	4W3675	75
70892	4W3380	67	72060	4W4010	84	72359	4W1070	13
70893	4W2310	37	72061	4W4015	84	72361	4W2995	56

CROSS REFERENCE

HALDEX - MEI

HALDEX	MEI	PAGE	HALDEX	MEI	PAGE	HALDEX	MEI	PAGE
72362	4W3095	59	72539	4W2025	28	72668	4W2530	43
72364	4W2375	38	72540	4W2305	36	72669	4W2535	43
72367	4W2335	37	72541	4W2675	47	72672	4W2695	47
72393	4W2865	52	72542	4W2105	31	72673	4W2550	43
72401	4W2380	39	72543	4W2035	29	72674	4W2555	43
72402	4W2385	39	72544	4W3655	75	72675	4W2560	44
72403	4W2185	33	72545	4W3660	75	72676	4W2705	48
72404	4W2190	33	72546	4W2880	53	72677	4W2885	53
72405	4W3010	57	72547	4W3665	75	72678	4W2275	35
72406	4W2180	33	72548	4W2395	39	72679	4W3790	79
72407	4W2670	47	72553	4W3070	58	72680	4W3760	78
72416	4W3015	57	72559	4W4355	92	72688	4W2785	50
72417	4W3440	69	72560	4W4360	92	72689	4W2790	50
72418	4W3445	69	72563	4W4365	92	72695	4W4175	88
72419	4W3740	77	72568	4W3460	69	72696	4W4180	88
72420	4W2200	33	72586	4W3505	71	72704	4W3700	76
72421	4W2205	33	72587	4W3510	71	72705	4W3705	76
72422	4W2195	33	72591	4W3575	73	72715	4W2565	44
72425	4W3940	82	72592	4W2975	55	72716	4W2570	44
72428	4W3455	69	72593	4W2055	29	72717	4W2575	44
72429	4W3450	69	72594	4W2050	29	72718	4W2580	44
72430	4W3630	74	72596	4W2420	40	72719	4W2900	53
72431	4W3635	74	72597	4W3105	59	72720	4W3210	62
72439	4W2345	37	72598	4W3110	60	72721	4W3805	79
72440	4W2350	38	72603	4W3515	71	72722	4W3810	79
72441	4W2340	37	72604	4W3580	73	72723	4W2285	36
72457	4W3025	57	72608	4W2400	39	72724	4W2290	36
72459	4W2775	50	72609	4W2425	40	72725	4W3710	77
72460	4W2780	50	72616	4W3075	58	72726	4W2295	36
72461	4W3035	57	72617	4W3080	59	72727	4W2585	44
72462	4W3030	57	72641	4W3295	65	72728	4W2590	45
72484	4W3715	77	72643	4W3620	74	72729	4W3520	71
72485	4W3720	77	72646	4W3225	63	72730	4W3525	71
72523	4W2010	28	72647	4W3230	63	72744	4W2270	35
72524	4W2015	28	72654	4W2710	48	72745	4W2265	35
72525	4W2115	31	72655	4W3310	65	72746	4W3245	63
72526	4W2125	31	72656	4W3305	65	72747	4W3250	63
72530	4W2760	49	72660	4W2220	34	72758	4W2085	30
72532	4W4305	91	72661	4W2260	35	72759	4W3590	73
72533	4W4310	91	72662	4W2250	35	72760	4W3585	73
72534	4W2030	29	72663	4W2215	34	72772	4W4105	87
72535	4W2515	42	72664	4W2210	34	72773	4W4110	87
72536	4W2110	31	72665	4W2520	43	72778	4W3640	75
72537	4W2120	31	72666	4W2525	43	72779	4W4060	85
72538	4W2020	28	72667	4W2255	35	72782	4W2280	36



CROSS REFERENCE

HALDEX - MEI

HALDEX	MEI	PAGE	HALDEX	MEI	PAGE	HALDEX	MEI	PAGE
72783	4W2300	36	72928	4W3950	83	79051	4W1185	17
72784	4W3140	60	72929	4W3645	75	79055	4W3615	74
72785	4W3135	60	72930	4W3650	75	79056	4W3900	81
72788	4W1000	12	72937	4W4390	93	79057	4W4035	85
72804	4W2915	54	72938	4W4395	93	79058	4W4040	85
72809	4W2930	54	72939	4W3300	65	79059	4W4025	85
72810	4W3155	61	72948	4W1035	13	79060	4W4030	85
72811	4W3815	79	72951	4W2680	47	79063	4W3750	77
72812	4W3820	79	72952	4W2850	52	79064	4W3745	77
72815	4W3005	56	72953	4W3935	82	79071	4W3610	74
72816	4W3000	56	72954	4W3320	65	79079	4W3905	81
72817	4W3530	71	72955	4W3315	65	79086	4W1300	19
72818	4W4050	85	79002	4W4380	92	79087	4W1305	19
72819	4W4055	85	79003	4W4385	92	79090	4W1245	18
72820	4W4100	87	79004	4W1025	12	79097	4W1085	14
72825	4W2360	38	79005	4W1030	13	79098	4W1090	14
72826	4W2595	45	79006	4W1265	18	79105	4W3550	72
72827	4W1340	20	79007	4W2815	51	79106	4W3555	72
72829	4W3355	66	79008	4W2820	51	79111	4W1240	18
72830	4W3360	67	79009	4W3825	79	79133	4W4135	87
72831	4W3535	71	79010	4W3830	80	79138	4W1320	19
72833	4W3975	83	79011	4W3205	62	79139	4W1325	19
72834	4W3980	83	79012	4W3835	80	79144	4W1280	18
72853	4W3020	57	79013	4W2240	35	79145	4W1285	19
72854	4W2935	54	79014	4W2230	34	79149	4W1270	18
72855	4W3065	58	79015	4W2225	34	79150	4W3195	62
72856	4W3765	78	79016	4W2245	35	79151	4W3200	62
72857	4W3770	78	79017	4W2795	50	79152	4W3220	63
72858	4W3605	73	79018	4W2800	51	79153	4W3215	62
72867	4W4435	93	79019	4W2980	56	79156	4W3325	65
72868	4W4440	93	79020	4W3085	59	79157	4W3330	66
72872	4W4285	91	79021	4W3090	59	79160	4W1180	16
72875	4W1005	12	79022	4W1020	12	79162	4W3415	68
72876	4W1010	12	79023	4W1015	12	79163	4W3410	68
72886	4W2725	48	79024	4W3425	68	79177	4W2955	55
72887	4W2730	49	79025	4W3430	69	79183	4W1170	16
72888	4W3995	84	79028	4W1205	17	79184	4W4140	88
72892	4W2600	45	79029	4W1210	17	79185	4W3365	67
72893	4W2605	45	79030	4W1225	17	79195	4W3725	77
72906	4W2685	47	79031	4W1230	17	79196	4W3730	77
72907	4W2690	47	79035	4W1040	13	79197	4W3185	61
72915	4W2660	47	79040	4W3680	76	79198	4W3190	62
72916	4W2665	47	79041	4W3685	76	79205	4W2610	45
72921	4W3955	83	79043	4W1330	19	79206	4W2615	45
72922	4W3960	83	79044	4W1335	20	79207	4W3400	68

CROSS REFERENCE

HALDEX - MEI

HALDEX	MEI	PAGE	HALDEX	MEI	PAGE	HALDEX	MEI	PAGE
79208	4W2070	30	79309	4W3050	58	79520	4W4445	94
79209	4W2075	30	79310	4W3040	57	79521	4W4450	94
79210	4W2095	30	79311	4W3045	57	79535	4W4490	95
79211	4W2090	30	79312	4W3850	80	79536	4W4495	95
79212	4W2080	30	79313	4W3855	80	79550	4W4480	95
79213	4W3370	67	79317	4W1135	15	79551	4W4485	95
79214	4W3375	67	79318	4W1130	15	79567	4W3865	81
79215	4W3625	74	79338	4W1140	15	79568	4W3870	81
79216	4W3265	64	79339	4W1145	15	79569	4W3860	81
79217	4W3270	64	79347	4W3545	72	79577	4W4295	91
79218	4W3420	68	79348	4W3540	72	79628	4W2870	53
79219	4W3340	66	79351	4W3920	82	79629	4W2875	53
79220	4W3335	66	79352	4W3925	82	79637	4W4415	93
79221	4W3690	76	79353	4W3930	82	79638	4W4420	93
79222	4W3695	76	79368	4W4275	91	79641	4W4255	90
79223	4W2620	45	79369	4W4280	91	79642	4W4260	90
79224	4W2625	45	79396	4W3965	83	79649	4W1275	18
79225	4W3115	60	79397	4W3970	83	79677	4W3910	81
79226	4W3120	60	79407	4W4315	91	79678	4W3915	82
79227	4W3165	61	79408	4W4320	91	79682	4W4215	89
79228	4W3350	66	79412	4W4065	85	79683	4W4460	94
79229	4W3345	66	79413	4W4070	86	79684	4W4465	94
79250	4W3595	73	79414	4W4075	86	79685	4W1235	17
79251	4W3600	73	79415	4W4080	86	79693	4W4475	95
79265	4W4205	89	79416	4W4095	86	79694	4W4470	94
79266	4W4210	89	79417	4W4085	86	79713	4W4190	89
79286	4W3235	63	79418	4W4090	86	79714	4W4195	89
79287	4W3240	63	79429	4W3180	61	79725	4W4425	93
79288	4W2905	53	79430	4W3175	61	79726	4W4430	93
79289	4W2910	54	79431	4W3275	64	79772	4W4455	94
79294	4W2920	54	79432	4W3280	64	79778	4W4235	89
79295	4W2925	54	79436	4W4185	88	79779	4W4240	89
79296	4W2630	46	79440	4W4200	89	79780	4W4245	90
79297	4W2635	46	79441	4W3755	78	79781	4W4250	90
79298	4W4265	90	79442	4W2735	49	80000	6Y6500	95
79299	4W2640	46	79443	4W2740	49	80001	6Y6505	95
79300	4W2645	46	79454	4W3560	72	80008	6Y6510	95
79301	4W2940	55	79455	4W3565	72	80009	6Y6515	96
79302	4W2945	55	79456	4W3570	73	80010	6Y6520	96
79303	4W4270	90	79461	4W4145	88	80011	6Y6525	96
79304	4W3485	70	79493	4W4000	84	80012	6Y6530	96
79305	4W3490	70	79494	4W4005	84	80013	6Y6535	96
79306	4W3840	80	79502	4W1125	15	80014	6Y6540	96
79307	4W3845	80	79503	4W1310	19	80018	6Y1640	23
79308	4W3055	58	79504	4W1315	19	80019	6Y1500	20



CROSS REFERENCE

HALDEX - MEI

HALDEX	MEI	PAGE
80020	6Y1505	20
80021	6Y1510	20
80022	6Y1515	20
80023	6Y1520	21
80024	6Y1525	21
80030	6Y6545	97
80032	6Y1585	22
80037	6Y1530	21
80041	6Y1535	21
80108	6Y1550	21
80122	6Y1710	25
80123	6Y1730	25
80124	6Y1560	21
80125	6Y1565	21
80126	6Y1570	21
80129	6Y1715	25
80130	6Y1720	25
80133	6Y6600	97
80134	6Y1580	22
80136	6Y1725	25
80176	6Y6620	97
80177	6Y6720	97
80178	6Y6725	97
80179	6Y6730	98
80180	6Y6630	97
80181	6Y6660	97
80183	6Y6625	97
80292	6Y1590	22
80293	6Y1595	22
80294	6Y1600	22
80295	6Y1605	22
80296	6Y1610	23
80297	6Y1615	23
80302	6Y1620	23
80303	6Y1645	23
80322	6Y1625	23
80331	6Y1630	23
80332	6Y1635	23
80380	6Y1675	24
80381	6Y1680	24
80382	6Y1690	24
80383	6Y1695	24
80384	6Y1700	25
80385	6Y1705	25
80409	6Y1685	24

CROSS REFERENCE

MEI - HALDEX

MEI	HALDEX	PAGE	MEI	HALDEX	PAGE	MEI	HALDEX	PAGE
4W1000	72788	12	4W1270	79149	18	4W2160	72173	32
4W1005	72875	12	4W1275	79649	18	4W2165	72062	32
4W1010	72876	12	4W1280	79144	18	4W2170	72181	33
4W1015	79023	12	4W1285	79145	19	4W2175	72199	33
4W1020	79022	12	4W1300	79086	19	4W2180	72406	33
4W1025	79004	12	4W1305	79087	19	4W2185	72403	33
4W1030	79005	13	4W1310	79503	19	4W2190	72404	33
4W1035	72948	13	4W1315	79504	19	4W2195	72422	33
4W1040	79035	13	4W1320	79138	19	4W2200	72420	33
4W1050	72266	13	4W1325	79139	19	4W2205	72421	33
4W1055	72261	13	4W1330	79043	19	4W2210	72664	34
4W1060	72268	13	4W1335	79044	20	4W2215	72663	34
4W1065	72256	13	4W1340	72827	20	4W2220	72660	34
4W1070	72359	13	4W2000	70823	28	4W2225	79015	34
4W1075	72250	14	4W2005	70871	28	4W2230	79014	34
4W1080	70949	14	4W2010	72523	28	4W2235	72180	34
4W1085	79097	14	4W2015	72524	28	4W2240	79013	35
4W1090	79098	14	4W2020	72538	28	4W2245	79016	35
4W1100	72282	14	4W2025	72539	28	4W2250	72662	35
4W1105	72253	14	4W2030	72534	29	4W2255	72667	35
4W1110	72239	15	4W2035	72543	29	4W2260	72661	35
4W1115	70802	15	4W2040	72059	29	4W2265	72745	35
4W1120	70803	15	4W2045	70954	29	4W2270	72744	35
4W1125	79502	15	4W2050	72594	29	4W2275	72678	35
4W1130	79318	15	4W2055	72593	29	4W2280	72782	36
4W1135	79317	15	4W2060	70953	29	4W2285	72723	36
4W1140	79338	15	4W2065	70952	29	4W2290	72724	36
4W1145	79339	15	4W2070	79208	30	4W2295	72726	36
4W1150	72255	16	4W2075	79209	30	4W2300	72783	36
4W1160	72238	16	4W2080	79212	30	4W2305	72540	36
4W1165	72104	16	4W2085	72758	30	4W2310	70893	37
4W1170	79183	16	4W2090	79211	30	4W2315	70945	37
4W1175	72103	16	4W2095	79210	30	4W2320	70626	37
4W1180	79160	16	4W2100	70775	31	4W2325	70859	37
4W1185	79051	17	4W2105	72542	31	4W2330	70624	37
4W1205	79028	17	4W2110	72536	31	4W2335	72367	37
4W1210	79029	17	4W2115	72525	31	4W2340	72441	37
4W1215	70969	17	4W2120	72537	31	4W2345	72439	37
4W1220	70970	17	4W2125	72526	31	4W2350	72440	38
4W1225	79030	17	4W2130	72213	31	4W2355	70583	38
4W1230	79031	17	4W2135	72036	31	4W2360	72825	38
4W1235	79685	17	4W2140	72037	32	4W2365	70512	38
4W1240	79111	18	4W2145	72063	32	4W2370	70634	38
4W1245	79090	18	4W2150	70867	32	4W2375	72364	38
4W1265	79006	18	4W2155	72174	32	4W2380	72401	39



CROSS REFERENCE

MEI - HALDEX

MEI	HALDEX	PAGE	MEI	HALDEX	PAGE	MEI	HALDEX	PAGE
4W2385	72402	39	4W2610	79205	45	4W2835	70530	51
4W2390	70582	39	4W2615	79206	45	4W2840	70917	52
4W2395	72548	39	4W2620	79223	45	4W2845	72177	52
4W2400	72608	39	4W2625	79224	45	4W2850	72952	52
4W2405	12254	39	4W2630	79296	46	4W2855	72234	52
4W2410	12255	39	4W2635	79297	46	4W2860	72326	52
4W2415	12256	39	4W2640	79299	46	4W2865	72393	52
4W2420	72596	40	4W2645	79300	46	4W2870	79628	53
4W2425	72609	40	4W2650	70510	46	4W2875	79629	53
4W2430	70532	40	4W2655	70511	46	4W2880	72546	53
4W2435	70627	40	4W2660	72915	47	4W2885	72677	53
4W2440	70706	40	4W2665	72916	47	4W2890	70785	53
4W2445	70753	40	4W2670	72407	47	4W2895	70786	53
4W2450	70832	41	4W2675	72541	47	4W2900	72719	53
4W2455	70833	41	4W2680	72951	47	4W2905	79288	53
4W2460	70905	41	4W2685	72906	47	4W2910	79289	54
4W2465	70906	41	4W2690	72907	47	4W2915	72804	54
4W2470	70918	41	4W2695	72672	47	4W2920	79294	54
4W2475	70943	41	4W2700	70894	48	4W2925	79295	54
4W2480	70944	41	4W2705	72676	48	4W2930	72809	54
4W2485	70977	41	4W2710	72654	48	4W2935	72854	54
4W2490	70978	42	4W2715	72211	48	4W2940	79301	55
4W2495	72105	42	4W2720	72212	48	4W2945	79302	55
4W2500	72106	42	4W2725	72886	48	4W2950	72069	55
4W2505	72203	42	4W2730	72887	49	4W2955	79177	55
4W2510	72204	42	4W2735	79442	49	4W2960	72330	55
4W2515	72535	42	4W2740	79443	49	4W2965	70720	55
4W2520	72665	43	4W2745	70810	49	4W2970	70931	55
4W2525	72666	43	4W2750	72038	49	4W2975	72592	55
4W2530	72668	43	4W2755	72039	49	4W2980	79019	56
4W2535	72669	43	4W2760	72530	49	4W2985	72145	56
4W2540	70923	43	4W2765	70754	49	4W2990	72235	56
4W2545	70924	43	4W2770	70762	50	4W2995	72361	56
4W2550	72673	43	4W2775	72459	50	4W3000	72816	56
4W2555	72674	43	4W2780	72460	50	4W3005	72815	56
4W2560	72675	44	4W2785	72688	50	4W3010	72405	57
4W2565	72715	44	4W2790	72689	50	4W3015	72416	57
4W2570	72716	44	4W2795	79017	50	4W3020	72853	57
4W2575	72717	44	4W2800	79018	51	4W3025	72457	57
4W2580	72718	44	4W2805	70824	51	4W3030	72462	57
4W2585	72727	44	4W2810	70825	51	4W3035	72461	57
4W2590	72728	45	4W2815	79007	51	4W3040	79310	57
4W2595	72826	45	4W2820	79008	51	4W3045	79311	57
4W2600	72892	45	4W2825	70986	51	4W3050	79309	58
4W2605	72893	45	4W2830	72070	51	4W3055	79308	58

CROSS REFERENCE

MEI - HALDEX

MEI	HALDEX	PAGE	MEI	HALDEX	PAGE	MEI	HALDEX	PAGE
4W3060	70891	58	4W3285	70990	64	4W3510	72587	71
4W3065	72855	58	4W3290	70991	65	4W3515	72603	71
4W3070	72553	58	4W3295	72641	65	4W3520	72729	71
4W3075	72616	58	4W3300	72939	65	4W3525	72730	71
4W3080	72617	59	4W3305	72656	65	4W3530	72817	71
4W3085	79020	59	4W3310	72655	65	4W3535	72831	71
4W3090	79021	59	4W3315	72955	65	4W3540	79348	72
4W3095	72362	59	4W3320	72954	65	4W3545	79347	72
4W3100	72333	59	4W3325	79156	65	4W3550	79105	72
4W3105	72597	59	4W3330	79157	66	4W3555	79106	72
4W3110	72598	60	4W3335	79220	66	4W3560	79454	72
4W3115	79225	60	4W3340	79219	66	4W3565	79455	72
4W3120	79226	60	4W3345	79229	66	4W3570	79456	73
4W3125	70772	60	4W3350	79228	66	4W3575	72591	73
4W3130	70771	60	4W3355	72829	66	4W3580	72604	73
4W3135	72785	60	4W3360	72830	67	4W3585	72760	73
4W3140	72784	60	4W3365	79185	67	4W3590	72759	73
4W3145	72040	60	4W3370	79213	67	4W3595	79250	73
4W3150	72041	61	4W3375	79214	67	4W3600	79251	73
4W3155	72810	61	4W3380	70892	67	4W3605	72858	73
4W3160	70809	61	4W3385	70919	67	4W3610	79071	74
4W3165	79227	61	4W3390	70987	67	4W3615	79055	74
4W3170	70930	61	4W3395	70988	67	4W3620	72643	74
4W3175	79430	61	4W3400	79207	68	4W3625	79215	74
4W3180	79429	61	4W3405	11011	68	4W3630	72430	74
4W3185	79197	61	4W3410	79163	68	4W3635	72431	74
4W3190	79198	62	4W3415	79162	68	4W3640	72778	75
4W3195	79150	62	4W3420	79218	68	4W3645	72929	75
4W3200	79151	62	4W3425	79024	68	4W3650	72930	75
4W3205	79011	62	4W3430	79025	69	4W3655	72544	75
4W3210	72720	62	4W3435	72329	69	4W3660	72545	75
4W3215	79153	62	4W3440	72417	69	4W3665	72547	75
4W3220	79152	63	4W3445	72418	69	4W3670	72357	75
4W3225	72646	63	4W3450	72429	69	4W3675	72358	75
4W3230	72647	63	4W3455	72428	69	4W3680	79040	76
4W3235	79286	63	4W3460	72568	69	4W3685	79041	76
4W3240	79287	63	4W3465	72035	69	4W3690	79221	76
4W3245	72746	63	4W3470	72034	70	4W3695	79222	76
4W3250	72747	63	4W3475	72033	70	4W3700	72704	76
4W3255	72014	63	4W3480	72178	70	4W3705	72705	76
4W3260	72015	64	4W3485	79304	70	4W3710	72725	77
4W3265	79216	64	4W3490	79305	70	4W3715	72484	77
4W3270	79217	64	4W3495	70903	70	4W3720	72485	77
4W3275	79431	64	4W3500	72085	71	4W3725	79195	77
4W3280	79432	64	4W3505	72586	71	4W3730	79196	77



CROSS REFERENCE

MEI - HALDEX

MEI	HALDEX	PAGE	MEI	HALDEX	PAGE	MEI	HALDEX	PAGE
4W3740	72419	77	4W4000	79493	84	4W4270	79303	90
4W3745	79064	77	4W4005	79494	84	4W4275	79368	91
4W3750	79063	77	4W4010	72060	84	4W4280	79369	91
4W3755	79441	78	4W4015	72061	84	4W4285	72872	91
4W3760	72680	78	4W4025	79059	85	4W4295	79577	91
4W3765	72856	78	4W4030	79060	85	4W4305	72532	91
4W3770	72857	78	4W4035	79057	85	4W4310	72533	91
4W3775	72179	78	4W4040	79058	85	4W4315	79407	91
4W3780	70869	78	4W4050	72818	85	4W4320	79408	91
4W3790	72679	79	4W4055	72819	85	4W4350	70764	92
4W3795	72054	79	4W4060	72779	85	4W4355	72559	92
4W3800	72055	79	4W4065	79412	85	4W4360	72560	92
4W3805	72721	79	4W4070	79413	86	4W4365	72563	92
4W3810	72722	79	4W4075	79414	86	4W4380	79002	92
4W3815	72811	79	4W4080	79415	86	4W4385	79003	92
4W3820	72812	79	4W4085	79417	86	4W4390	72937	93
4W3825	79009	79	4W4090	79418	86	4W4395	72938	93
4W3830	79010	80	4W4095	79416	86	4W4415	79637	93
4W3835	79012	80	4W4100	72820	87	4W4420	79638	93
4W3840	79306	80	4W4105	72772	87	4W4425	79725	93
4W3845	79307	80	4W4110	72773	87	4W4430	79726	93
4W3850	79312	80	4W4115	70542	87	4W4435	72867	93
4W3855	79313	80	4W4120	70543	87	4W4440	72868	93
4W3860	79569	81	4W4125	70975	87	4W4445	79520	94
4W3865	79567	81	4W4130	70976	87	4W4450	79521	94
4W3870	79568	81	4W4135	79133	87	4W4455	79772	94
4W3890	72064	81	4W4140	79184	88	4W4460	79683	94
4W3895	72065	81	4W4145	79461	88	4W4465	79684	94
4W3900	79056	81	4W4170	70870	88	4W4470	79694	94
4W3905	79079	81	4W4175	72695	88	4W4475	79693	95
4W3910	79677	81	4W4180	72696	88	4W4480	79550	95
4W3915	79678	82	4W4185	79436	88	4W4485	79551	95
4W3920	79351	82	4W4190	79713	89	4W4490	79535	95
4W3925	79352	82	4W4195	79714	89	4W4495	79536	95
4W3930	79353	82	4W4200	79440	89	6Y1500	80019	20
4W3935	72953	82	4W4205	79265	89	6Y1505	80020	20
4W3940	72425	82	4W4210	79266	89	6Y1510	80021	20
4W3950	72928	83	4W4215	79682	89	6Y1515	80022	20
4W3955	72921	83	4W4235	79778	89	6Y1520	80023	21
4W3960	72922	83	4W4240	79779	89	6Y1525	80024	21
4W3965	79396	83	4W4245	79780	90	6Y1530	80037	21
4W3970	79397	83	4W4250	79781	90	6Y1535	80041	21
4W3975	72833	83	4W4255	79641	90	6Y1550	80108	21
4W3980	72834	83	4W4260	79642	90	6Y1560	80124	21
4W3995	72888	84	4W4265	79298	90	6Y1565	80125	21

CROSS REFERENCE

MEI - HALDEX

MEI	HALDEX	PAGE
6Y1570	80126	21
6Y1580	80134	22
6Y1585	80032	22
6Y1590	80292	22
6Y1595	80293	22
6Y1600	80294	22
6Y1605	80295	22
6Y1610	80296	23
6Y1615	80297	23
6Y1620	80302	23
6Y1625	80322	23
6Y1630	80331	23
6Y1635	80332	23
6Y1640	80018	23
6Y1645	80303	23
6Y1675	80380	24
6Y1680	80381	24
6Y1685	80409	24
6Y1690	80382	24
6Y1695	80383	24
6Y1700	80384	25
6Y1705	80385	25
6Y1710	80122	25
6Y1715	80129	25
6Y1720	80130	25
6Y1725	80136	25
6Y1730	80123	25
6Y6500	80000	95
6Y6505	80001	95
6Y6510	80008	95
6Y6515	80009	96
6Y6520	80010	96
6Y6525	80011	96
6Y6530	80012	96
6Y6535	80013	96
6Y6540	80014	96
6Y6545	80030	97
6Y6600	80133	97
6Y6620	80176	97
6Y6625	80183	97
6Y6630	80180	97
6Y6660	80181	97
6Y6720	80177	97
6Y6725	80178	97
6Y6730	80179	98



CROSS REFERENCE

OEM - MEI

OEM	MEI	PAGE	OEM	MEI	PAGE	OEM	MEI	PAGE
0003520840	4W4420	93	0537538	4W2030	29	09319459	4W1320	19
0003520940	4W4415	93	0538470	4W3505	71	09319460	4W1325	19
0097774	4W3790	79	0538471	4W3510	71	09319467	6Y1680	24
0097775	4W3760	78	0557482433	6Y8011	26	09319468	6Y1675	24
014265271135	4W3015	57	0557482863	6Y8061	27	1042976	4W3940	82
0159556	4W2010	28	0557482873	6Y8001	26	10551439	4W3410	68
0159557	4W2015	28	0557482883	6Y8041	26	10889962	4W2320	37
0159558	4W2115	31	0557483013	6Y8031	26	10889963	4W2435	40
0159559	4W2125	31	0557483073	6Y8051	26	10891012	4W2370	38
0159560	4W2760	49	0557483083	6Y8021	26	10901188	4W2330	37
0159561	4W2105	31	0557488223	6Y8071	27	10901199	4W2355	38
0159562	4W2035	29	0557488233	6Y8092	27	10901200	4W2390	39
0159563	4W3655	75	0557488233	6Y8093	27	10907244	4W2650	46
0159564	4W3660	75	0557488243	6Y8102	27	10907245	4W2655	46
0159565	4W2515	42	0557488243	6Y8103	27	10907246	4W2365	38
0159569	4W2880	53	0557488323	6Y8082	27	1112829	4W2215	34
0159576	4W3665	75	0557488323	6Y8083	27	1112830	4W2210	34
0159577	4W2395	39	070276010	4W2785	50	1112835	4W2525	43
0159578	4W3070	58	070276011	4W2790	50	1112836	4W2520	43
0159587	4W2110	31	0740321	4W2400	39	1112839	4W2360	38
0159588	4W2120	31	0740322	4W2425	40	1112840	4W2595	45
0159589	4W2020	28	0755247	4W4175	88	1112841	4W2710	48
0159590	4W2025	28	0755248	4W4180	88	1134293	4W2575	44
0159591	4W2305	36	0755616	4W3700	76	1134294	4W2580	44
0159592	4W2675	47	0755617	4W3705	76	1134295	4W2565	44
0178529	4W3495	70	080250000	4W2845	52	1134296	4W2570	44
0517454410	4W1220	17	09319035	4W1275	18	1134451	4W2900	53
0517454420	4W1215	17	09319434	6Y1550	21	1134452	4W3210	62
0517482122	4W1010	12	09319437	6Y1560	21	1134829	4W3805	79
0517482212	4W1005	12	09319438	6Y1565	21	1134830	4W3810	79
0517482212	6Y1500	20	09319439	6Y1570	21	1135004	4W2255	35
0517482213	6Y8011	26	09319440	6Y1580	22	1135394	4W2685	47
0517482443	6Y8021	26	09319441	6Y1690	24	1135395	4W2690	47
0517482473	6Y8061	27	09319442	6Y1695	24	1136430	4W2660	47
0517482633	6Y8001	26	09319443	6Y1725	25	1136431	4W2665	47
0517482673	6Y8031	26	09319444	6Y1715	25	1136432	4W2285	36
0517483043	6Y8041	26	09319445	6Y1720	25	1136433	4W2290	36
0517483053	6Y8051	26	09319446	6Y1685	24	1195461	4W2280	36
0517488513	6Y8071	27	09319447	6Y1710	25	1195462	4W2300	36
0517488683	6Y8092	27	09319448	6Y1705	25	1196321	4W2275	35
0517488693	6Y8093	27	09319449	6Y1700	25	1196322	4W2295	36
0517488703	6Y8102	27	09319450	6Y1730	25	1197965	4W3140	60
0517488713	6Y8103	27	09319456	4W1270	18	1197966	4W3135	60
0517488953	6Y8082	27	09319457	4W1280	18	1242597	4W3975	83
0517488963	6Y8083	27	09319458	4W1285	19	1242598	4W3980	83

Cross Reference

Manufacturers' and other wholesaler's part numbers used in this catalogue are for cross reference purposes only and do not imply anything about the origin or manufacturer of the product.

CROSS REFERENCE

OEM - MEI

OEM	MEI	PAGE	OEM	MEI	PAGE	OEM	MEI	PAGE
1263485	4W2725	48	218834	4W2265	35	3834200538	4W2140	32
1263486	4W2730	49	219997	4W3310	65	3854201138	4W2840	52
1282111	4W3425	68	219998	4W3305	65	3854201238	4W2470	41
1282112	4W3430	69	2700020000	4W2235	34	3854201738	4W3145	60
1324357	4W3550	72	2700021000	4W2170	33	3854201838	4W3150	61
1324358	4W3555	72	2700040000	4W3300	65	3874200038	4W2160	32
1465300611	4W3455	69	2700046000	4W2175	33	3874200138	4W2155	32
1465300811	4W3450	69	276525	4W2680	47	3894200338	4W2445	40
1586190	4W2530	43	276526	4W2850	52	3894200438	4W2765	49
1586191	4W2535	43	3014201138	4W2130	31	3894200738	4W2150	32
1586192	4W2540	43	3054202638	4W2440	40	394183	4W3715	77
1586193	4W2545	43	3074200138	4W3125	60	394184	4W3720	77
1592871	4W2695	47	3074200238	4W3130	60	394193	4W2600	45
1592872	4W2550	43	3074200338	4W2100	31	394194	4W2605	45
1592873	4W2555	43	3074201738	4W3890	81	394195	4W3520	71
1592874	4W2560	44	3074201838	4W3895	81	394196	4W3525	71
1592875	4W3710	77	308677	4W3935	82	4175008501	4W1075	14
1592876	4W2705	48	3136246	4W4255	90	4175013900	4W1160	16
1592877	4W2885	53	3136247	4W4260	90	4175014000	4W1110	15
1789560	4W2250	35	3177673	4W2960	55	4175014900	4W1135	15
1789561	4W2220	34	3193400	4W3910	81	4175015000	4W1130	15
1789562	4W2260	35	3193401	4W3915	82	4175023000	4W1340	20
1789563	4W3545	72	3193402	4W4190	89	4175023500	4W1330	19
1789564	4W3540	72	3193403	4W4195	89	4175023600	4W1335	20
1789565	4W4485	95	321469	4W3315	65	4175023700	4W1300	19
1789566	4W4480	95	321470	4W3320	65	4175023800	4W1305	19
1789567	4W2735	49	3231273	4W3645	75	4175024700	4W1265	18
1789568	4W2740	49	3231343	4W3650	75	4175024800	4W1040	13
1789571	4W2585	44	3434350202	4W1080	14	4175024900	4W1030	13
1789572	4W2590	45	3454200738	4W2950	55	4175024900	6Y1515	20
21217568	4W1070	13	3454200838	4W2830	51	4175025100	4W1145	15
21217569	4W1055	13	3454201238	4W3480	70	4175025200	4W1140	15
21229249	4W1000	12	3574200538	4W2040	29	4175026200	6Y1535	21
21229249	6Y1505	20	3574200638	4W4010	84	4175031000	6Y1625	23
21229250	4W1115	15	3574200738	4W4015	84	4175032300	6Y1615	23
21229251	4W1120	15	3574201138	4W2715	48	4175032400	6Y1610	23
21229280	4W1085	14	3574201238	4W2720	48	4175032500	6Y1595	22
21229281	4W1090	14	3574201338	4W2930	54	4175032600	6Y1600	22
21229285	4W1205	17	3574201438	4W3155	61	4175032700	6Y1645	23
21229286	4W1210	17	3574201538	4W3815	79	4175032800	6Y1620	23
21229287	4W1185	17	3574201638	4W3820	79	4175032900	6Y1635	23
21229288	4W1245	18	3714200038	4W3365	67	4175033000	6Y1630	23
21229289	4W1180	16	3764200038	4W3285	64	4175033100	6Y1590	22
21229290	4W1170	16	3764200138	4W3290	65	4175037400	6Y1605	22
218833	4W2270	35	3834200438	4W2135	31	4175037500	6Y1640	23



CROSS REFERENCE

OEM - MEI

OEM	MEI	PAGE	OEM	MEI	PAGE	OEM	MEI	PAGE
4175039400	4W1035	13	5010260023	4W3840	80	651777	4W2865	52
4692759	4W2745	49	5010260024	4W3845	80	6524200038	4W2055	29
4695754	4W3160	61	5010260027	4W3485	70	6524200138	4W2050	29
474801790	4W2405	39	5010260028	4W3490	70	6524200238	4W2420	40
474801801	4W2415	39	5010260115	4W3055	58	653509	4W2995	56
474901180	4W2410	39	5010260116	4W3050	58	6544200038	4W3105	59
4940871	4W3500	71	5010260117	4W3040	57	6544200138	4W3110	60
5000445830	4W3205	62	5010260118	4W3045	57	656007-29	4W3330	66
5000445898	4W3835	80	5010260379	4W3850	80	656007-30	4W3325	65
5000785203	4W3220	63	5010260380	4W3855	80	656995-104	4W3180	61
5000785204	4W3215	62	5430053192	4W4490	95	656995-105	4W3175	61
5000785205	4W3195	62	5430053193	4W4495	95	6863906	4W2455	41
5000785206	4W3200	62	5465302011	4W3965	83	6863907	4W2450	41
5000787230	4W3275	64	5465302021	4W3970	83	81506106160	4W3730	77
5000787231	4W3280	64	5801108076	4W4445	94	81506106161	4W3725	77
5000787264	4W2815	51	5801108078	4W4450	94	81506106189	4W3185	61
5000787265	4W2820	51	5801112932	4W4435	93	81506106190	4W3190	62
5000788696	4W3825	79	5801112933	4W4440	93	81506106203	4W3335	66
5000788697	4W3830	80	611484	4W2325	37	81506106204	4W3340	66
5000789894	4W2225	34	611485	4W2825	51	81506106205	4W3270	64
5000789895	4W2245	35	612051	4W2985	56	81506106206	4W3265	64
5000791212	4W2795	50	6174200238	4W2045	29	81506106207	4W3375	67
5000791213	4W2800	51	6174200338	4W2065	29	81506106208	4W3370	67
5001048	4W3385	67	6174200438	4W2060	29	81506106209	4W3625	74
5010013393	4W3085	59	6194200038	4W2165	32	81506106210	4W2075	30
5010013394	4W3090	59	6194200138	4W2145	32	81506106211	4W2070	30
5010037900	4W2980	56	6194200238	4W2855	52	81506106212	4W2090	30
5010056685	4W2240	35	6194200338	4W2990	56	81506106213	4W2095	30
5010056686	4W2230	34	6194200638	4W3075	58	81506106214	4W2610	45
5010067156	4W2870	53	6194200738	4W3080	59	81506106215	4W2615	45
5010067157	4W2875	53	6234200038	4W3795	79	81506106216	4W3165	61
5010098831	4W2905	53	6234200138	4W3800	79	81506106217	4W3400	68
5010098832	4W2910	54	6234200638	4W2755	49	81506106218	4W3695	76
5010098860	4W2920	54	6234200738	4W2750	49	81506106219	4W3690	76
5010098861	4W2925	54	633104590	4W2460	41	81506106220	4W2620	45
5010098862	4W2630	46	633104610	4W2775	50	81506106221	4W2625	45
5010098863	4W2635	46	633104620	4W2780	50	81506106222	4W3115	60
5010145883	4W3235	63	633104690	4W3030	57	81506106223	4W3120	60
5010145884	4W3240	63	633104700	4W3035	57	81506106224	4W4470	94
5010152965	4W4270	90	633106140	4W3230	63	81506106225	4W4475	95
5010201995	4W4265	90	633106150	4W3225	63	81506106226	4W3420	68
5010216843	4W2640	46	633106650	4W2860	52	81506106228	4W3350	66
5010216844	4W2645	46	651623	4W2375	38	81506106229	4W3345	66
5010216904	4W2940	55	651626	4W3095	59	81506106231	4W2080	30
5010216905	4W2945	55	651777	4W2335	37	81506106246	4W4425	93

CROSS REFERENCE

OEM - MEI

OEM	MEI	PAGE	OEM	MEI	PAGE
81506106247	4W4430	93	ACU6980	4W2495	42
81506106250	4W4455	94	ACU6981	4W2500	42
81506106259	6Y6725	97	ACU8342	4W2380	39
81506106260	6Y6730	98	ACU8343	4W2385	39
81506106261	6Y6630	97	ACU8344	4W2185	33
81506106262	6Y6660	97	ACU8345	4W2190	33
81506106263	6Y6620	97	ACU8346	4W3010	57
81506106264	6Y6720	97	ACU8347	4W2180	33
81506106266	6Y6625	97	ACU8348	4W2670	47
8238000835	4W2085	30	AJB0092001	4W1050	13
82830003040	4W2965	55	AJB0743001	4W1020	12
82830005520	4W3255	63	AJB0743001	6Y1510	20
82830005530	4W3260	64	B510642	4W2510	42
82850000890	4W3685	76	B510643	4W2505	42
82850000900	4W3680	76	BCU5534	4W2200	33
82850002130	4W3575	73	BCU5535	4W2205	33
82850002140	4W2975	55	BCU5536	4W2195	33
8398385	4W2490	42	BCU5767	4W2345	37
8398386	4W2485	41	BCU5768	4W2350	38
843685	4W2835	51	BCU5769	4W2340	37
866101	4W2430	40	CAL2240	4W2890	53
9002105	4W1015	12	CAL2241	4W2895	53
9002105	6Y1525	21	CF351148	4W1175	16
9007271	4W2805	51	GV12790	6Y1660	24
9007272	4W2810	51	L2220055	4W2955	55
914264	4W2915	54	MO02416	4W1025	12
914265	4W3535	71	MO02416	6Y1520	21
915286	4W3355	66	R9813F	4W3610	74
915287	4W3360	67	X1811183	4W2310	37
9454200038	6Y6510	95	X1811184	4W2700	48
9454200138	6Y6515	96	X2210967	4W3170	61
9454200238	6Y6500	95	Y537146	4W1060	13
9454200338	6Y6505	95			
9454200438	6Y6540	96			
9454200538	6Y6530	96			
9454200638	6Y6535	96			
9454200738	6Y6525	96			
9454200838	6Y6520	96			
9454200938	6Y6545	97			
ABU6924	4W2465	41			
ACU3627	4W2475	41			
ACU3628	4W2480	41			
ACU3629	4W2315	37			
ACU4866	4W3390	67			
ACU4867	4W3395	67			



CROSS REFERENCE

MEI - OEM

MEI	OEM	PAGE	MEI	OEM	PAGE	MEI	OEM	PAGE
4W1000	21229249	12	4W1340	4175023000	20	4W2230	5010056686	34
4W1005	0517482212	12	4W2010	0159556	28	4W2235	2700020000	34
4W1010	0517482122	12	4W2015	0159557	28	4W2240	5010056685	35
4W1015	9002105	12	4W2020	0159589	28	4W2245	5000789895	35
4W1020	AJB0743001	12	4W2025	0159590	28	4W2250	1789560	35
4W1025	MO02416	12	4W2030	0537538	29	4W2255	1135004	35
4W1030	4175024900	13	4W2035	0159562	29	4W2260	1789562	35
4W1035	4175039400	13	4W2040	3574200538	29	4W2265	218834	35
4W1040	4175024800	13	4W2045	6174200238	29	4W2270	218833	35
4W1050	AJB0092001	13	4W2050	6524200138	29	4W2275	1196321	35
4W1055	21217569	13	4W2055	6524200038	29	4W2280	1195461	36
4W1060	Y537146	13	4W2060	6174200438	29	4W2285	1136432	36
4W1070	21217568	13	4W2065	6174200338	29	4W2290	1136433	36
4W1075	4175008501	14	4W2070	81506106211	30	4W2295	1196322	36
4W1080	3434350202	14	4W2075	81506106210	30	4W2300	1195462	36
4W1085	21229280	14	4W2080	81506106231	30	4W2305	0159591	36
4W1090	21229281	14	4W2085	8238000835	30	4W2310	X1811183	37
4W1110	4175014000	15	4W2090	81506106212	30	4W2315	ACU3629	37
4W1115	21229250	15	4W2095	81506106213	30	4W2320	10889962	37
4W1120	21229251	15	4W2100	3074200338	31	4W2325	611484	37
4W1130	4175015000	15	4W2105	0159561	31	4W2330	10901188	37
4W1135	4175014900	15	4W2110	0159587	31	4W2335	651777	37
4W1140	4175025200	15	4W2115	0159558	31	4W2340	BCU5769	37
4W1145	4175025100	15	4W2120	0159588	31	4W2345	BCU5767	37
4W1160	4175013900	16	4W2125	0159559	31	4W2350	BCU5768	38
4W1170	21229290	16	4W2130	3014201138	31	4W2355	10901199	38
4W1175	CF351148	16	4W2135	3834200438	31	4W2360	1112839	38
4W1180	21229289	16	4W2140	3834200538	32	4W2365	10907246	38
4W1185	21229287	17	4W2145	6194200138	32	4W2370	10891012	38
4W1205	21229285	17	4W2150	3894200738	32	4W2375	651623	38
4W1210	21229286	17	4W2155	3874200138	32	4W2380	ACU8342	39
4W1215	0517454420	17	4W2160	3874200038	32	4W2385	ACU8343	39
4W1220	0517454410	17	4W2165	6194200038	32	4W2390	10901200	39
4W1245	21229288	18	4W2170	2700021000	33	4W2395	0159577	39
4W1265	4175024700	18	4W2175	2700046000	33	4W2400	0740321	39
4W1270	09319456	18	4W2180	ACU8347	33	4W2405	474801790	39
4W1275	09319035	18	4W2185	ACU8344	33	4W2410	474901180	39
4W1280	09319457	18	4W2190	ACU8345	33	4W2415	474801801	39
4W1285	09319458	19	4W2195	BCU5536	33	4W2420	6524200238	40
4W1300	4175023700	19	4W2200	BCU5534	33	4W2425	0740322	40
4W1305	4175023800	19	4W2205	BCU5535	33	4W2430	866101	40
4W1320	09319459	19	4W2210	1112830	34	4W2435	10889963	40
4W1325	09319460	19	4W2215	1112829	34	4W2440	3054202638	40
4W1330	4175023500	19	4W2220	1789561	34	4W2445	3894200338	40
4W1335	4175023600	20	4W2225	5000789894	34	4W2450	6863907	41

CROSS REFERENCE

MEI - OEM

MEI	OEM	PAGE	MEI	OEM	PAGE	MEI	OEM	PAGE
4W2455	6863906	41	4W2680	276525	47	4W2910	5010098832	54
4W2460	633104590	41	4W2685	1135394	47	4W2915	914264	54
4W2465	ABU6924	41	4W2690	1135395	47	4W2920	5010098860	54
4W2470	3854201238	41	4W2695	1592871	47	4W2925	5010098861	54
4W2475	ACU3627	41	4W2700	X1811184	48	4W2930	3574201338	54
4W2480	ACU3628	41	4W2705	1592876	48	4W2940	5010216904	55
4W2485	8398386	41	4W2710	1112841	48	4W2945	5010216905	55
4W2490	8398385	42	4W2715	3574201138	48	4W2950	3454200738	55
4W2495	ACU6980	42	4W2720	3574201238	48	4W2955	L2220055	55
4W2500	ACU6981	42	4W2725	1263485	48	4W2960	3177673	55
4W2505	B510643	42	4W2730	1263486	49	4W2965	82830003040	55
4W2510	B510642	42	4W2735	1789567	49	4W2975	82850002140	55
4W2515	0159565	42	4W2740	1789568	49	4W2980	5010037900	56
4W2520	1112836	43	4W2745	4692759	49	4W2985	612051	56
4W2525	1112835	43	4W2750	6234200738	49	4W2990	6194200338	56
4W2530	1586190	43	4W2755	6234200638	49	4W2995	653509	56
4W2535	1586191	43	4W2760	0159560	49	4W3010	ACU8346	57
4W2540	1586192	43	4W2765	3894200438	49	4W3015	014265271135	57
4W2545	1586193	43	4W2775	633104610	50	4W3030	633104690	57
4W2550	1592872	43	4W2780	633104620	50	4W3035	633104700	57
4W2555	1592873	43	4W2785	070276010	50	4W3040	5010260117	57
4W2560	1592874	44	4W2790	070276011	50	4W3045	5010260118	57
4W2565	1134295	44	4W2795	5000791212	50	4W3050	5010260116	58
4W2570	1134296	44	4W2800	5000791213	51	4W3055	5010260115	58
4W2575	1134293	44	4W2805	9007271	51	4W3070	0159578	58
4W2580	1134294	44	4W2810	9007272	51	4W3075	6194200638	58
4W2585	1789571	44	4W2815	5000787264	51	4W3080	6194200738	59
4W2590	1789572	45	4W2820	5000787265	51	4W3085	5010013393	59
4W2595	1112840	45	4W2825	611485	51	4W3090	5010013394	59
4W2600	394193	45	4W2830	3454200838	51	4W3095	651626	59
4W2605	394194	45	4W2835	843685	51	4W3105	6544200038	59
4W2610	81506106214	45	4W2840	3854201138	52	4W3110	6544200138	60
4W2615	81506106215	45	4W2845	080250000	52	4W3115	81506106222	60
4W2620	81506106220	45	4W2850	276526	52	4W3120	81506106223	60
4W2625	81506106221	45	4W2855	6194200238	52	4W3125	3074200138	60
4W2630	5010098862	46	4W2860	633106650	52	4W3130	3074200238	60
4W2635	5010098863	46	4W2865	651777	52	4W3135	1197966	60
4W2640	5010216843	46	4W2870	5010067156	53	4W3140	1197965	60
4W2645	5010216844	46	4W2875	5010067157	53	4W3145	3854201738	60
4W2650	10907244	46	4W2880	0159569	53	4W3150	3854201838	61
4W2655	10907245	46	4W2885	1592877	53	4W3155	3574201438	61
4W2660	1136430	47	4W2890	CAL2240	53	4W3160	4695754	61
4W2665	1136431	47	4W2895	CAL2241	53	4W3165	81506106216	61
4W2670	ACU8348	47	4W2900	1134451	53	4W3170	X2210967	61
4W2675	0159592	47	4W2905	5010098831	53	4W3175	656995-105	61



CROSS REFERENCE

MEI - OEM

MEI	OEM	PAGE	MEI	OEM	PAGE	MEI	OEM	PAGE
4W3180	656995-104	61	4W3450	1465300811	69	4W3835	5000445898	80
4W3185	81506106189	61	4W3455	1465300611	69	4W3840	5010260023	80
4W3190	81506106190	62	4W3480	3454201238	70	4W3845	5010260024	80
4W3195	5000785205	62	4W3485	5010260027	70	4W3850	5010260379	80
4W3200	5000785206	62	4W3490	5010260028	70	4W3855	5010260380	80
4W3205	5000445830	62	4W3495	0178529	70	4W3890	3074201738	81
4W3210	1134452	62	4W3500	4940871	71	4W3895	3074201838	81
4W3215	5000785204	62	4W3505	0538470	71	4W3910	3193400	81
4W3220	5000785203	63	4W3510	0538471	71	4W3915	3193401	82
4W3225	633106150	63	4W3520	394195	71	4W3935	308677	82
4W3230	633106140	63	4W3525	394196	71	4W3940	1042976	82
4W3235	5010145883	63	4W3535	914265	71	4W3965	5465302011	83
4W3240	5010145884	63	4W3540	1789564	72	4W3970	5465302021	83
4W3255	82830005520	63	4W3545	1789563	72	4W3975	1242597	83
4W3260	82830005530	64	4W3550	1324357	72	4W3980	1242598	83
4W3265	81506106206	64	4W3555	1324358	72	4W4010	3574200638	84
4W3270	81506106205	64	4W3575	82850002130	73	4W4015	3574200738	84
4W3275	5000787230	64	4W3610	R9813F	74	4W4175	0755247	88
4W3280	5000787231	64	4W3625	81506106209	74	4W4180	0755248	88
4W3285	3764200038	64	4W3645	3231273	75	4W4190	3193402	89
4W3290	3764200138	65	4W3650	3231343	75	4W4195	3193403	89
4W3300	2700040000	65	4W3655	0159563	75	4W4255	3136246	90
4W3305	219998	65	4W3660	0159564	75	4W4260	3136247	90
4W3310	219997	65	4W3665	0159576	75	4W4265	5010201995	90
4W3315	321469	65	4W3680	82850000900	76	4W4270	5010152965	90
4W3320	321470	65	4W3685	82850000890	76	4W4415	0003520940	93
4W3325	656007-30	65	4W3690	81506106219	76	4W4420	0003520840	93
4W3330	656007-29	66	4W3695	81506106218	76	4W4425	81506106246	93
4W3335	81506106203	66	4W3700	0755616	76	4W4430	81506106247	93
4W3340	81506106204	66	4W3705	0755617	76	4W4435	5801112932	93
4W3345	81506106229	66	4W3710	1592875	77	4W4440	5801112933	93
4W3350	81506106228	66	4W3715	394183	77	4W4445	5801108076	94
4W3355	915286	66	4W3720	394184	77	4W4450	5801108078	94
4W3360	915287	67	4W3725	81506106161	77	4W4455	81506106250	94
4W3365	3714200038	67	4W3730	81506106160	77	4W4470	81506106224	94
4W3370	81506106208	67	4W3760	0097775	78	4W4475	81506106225	95
4W3375	81506106207	67	4W3790	0097774	79	4W4480	1789566	95
4W3385	5001048	67	4W3795	6234200038	79	4W4485	1789565	95
4W3390	ACU4866	67	4W3800	6234200138	79	4W4490	5430053192	95
4W3395	ACU4867	67	4W3805	1134829	79	4W4495	5430053193	95
4W3400	81506106217	68	4W3810	1134830	79	6Y1500	0517482212	20
4W3410	10551439	68	4W3815	3574201538	79	6Y1505	21229249	20
4W3420	81506106226	68	4W3820	3574201638	79	6Y1510	AJB0743001	20
4W3425	1282111	68	4W3825	5000788696	79	6Y1515	4175024900	20
4W3430	1282112	69	4W3830	5000788697	80	6Y1520	MO02416	21

Cross Reference

Manufacturers' and other wholesaler's part numbers used in this catalogue are for cross reference purposes only and do not imply anything about the origin or manufacturer of the product.

CROSS REFERENCE

MEI - OEM

MEI	OEM	PAGE	MEI	OEM	PAGE
6Y1525	9002105	21	6Y6660	81506106262	97
6Y1535	4175026200	21	6Y6720	81506106264	97
6Y1550	09319434	21	6Y6725	81506106259	97
6Y1560	09319437	21	6Y6730	81506106260	98
6Y1565	09319438	21	6Y8001	0517482633	26
6Y1570	09319439	21	6Y8001	0557482873	26
6Y1580	09319440	22	6Y8011	0517482213	26
6Y1590	4175033100	22	6Y8011	0557482433	26
6Y1595	4175032500	22	6Y8021	0517482443	26
6Y1600	4175032600	22	6Y8021	0557483083	26
6Y1605	4175037400	22	6Y8031	0517482673	26
6Y1610	4175032400	23	6Y8031	0557483013	26
6Y1615	4175032300	23	6Y8041	0517483043	26
6Y1620	4175032800	23	6Y8041	0557482883	26
6Y1625	4175031000	23	6Y8051	0517483053	26
6Y1630	4175033000	23	6Y8051	0557483073	26
6Y1635	4175032900	23	6Y8061	0517482473	27
6Y1640	4175037500	23	6Y8061	0557482863	27
6Y1645	4175032700	23	6Y8071	0517488513	27
6Y1660	GV12790	24	6Y8071	0557488223	27
6Y1675	09319468	24	6Y8082	0517488953	27
6Y1680	09319467	24	6Y8082	0557488323	27
6Y1685	09319446	24	6Y8083	0517488963	27
6Y1690	09319441	24	6Y8083	0557488323	27
6Y1695	09319442	24	6Y8092	0517488683	27
6Y1700	09319449	25	6Y8092	0557488233	27
6Y1705	09319448	25	6Y8093	0517488693	27
6Y1710	09319447	25	6Y8093	0557488233	27
6Y1715	09319444	25	6Y8102	0517488703	27
6Y1720	09319445	25	6Y8102	0557488243	27
6Y1725	09319443	25	6Y8103	0517488713	27
6Y1730	09319450	25	6Y8103	0557488243	27
6Y6500	9454200238	95			
6Y6505	9454200338	95			
6Y6510	9454200038	95			
6Y6515	9454200138	96			
6Y6520	9454200838	96			
6Y6525	9454200738	96			
6Y6530	9454200538	96			
6Y6535	9454200638	96			
6Y6540	9454200438	96			
6Y6545	9454200938	97			
6Y6620	81506106263	97			
6Y6625	81506106266	97			
6Y6630	81506106261	97			



NOTES

NOTES



NOTES



Contact:
+ 44 (0) 114 2564601
sales@meibrakes.com