

D24W/D30W Water Heater

Installation
Troubleshooting &
Parts Manual



For Heater Models

D24W

25 1869 01 00 00
25 1870 01 00 00 (NP)
25 1869 05 00 00 (C)
25 1870 05 00 00 (C) (NP)

D30W

25 1871 01 00 00
25 1872 01 00 00 (NP)
25 1871 05 00 00 (C)
25 1872 05 00 00 (C) (NP)

(C) - Compact
(NP)-Nozzle Preheat

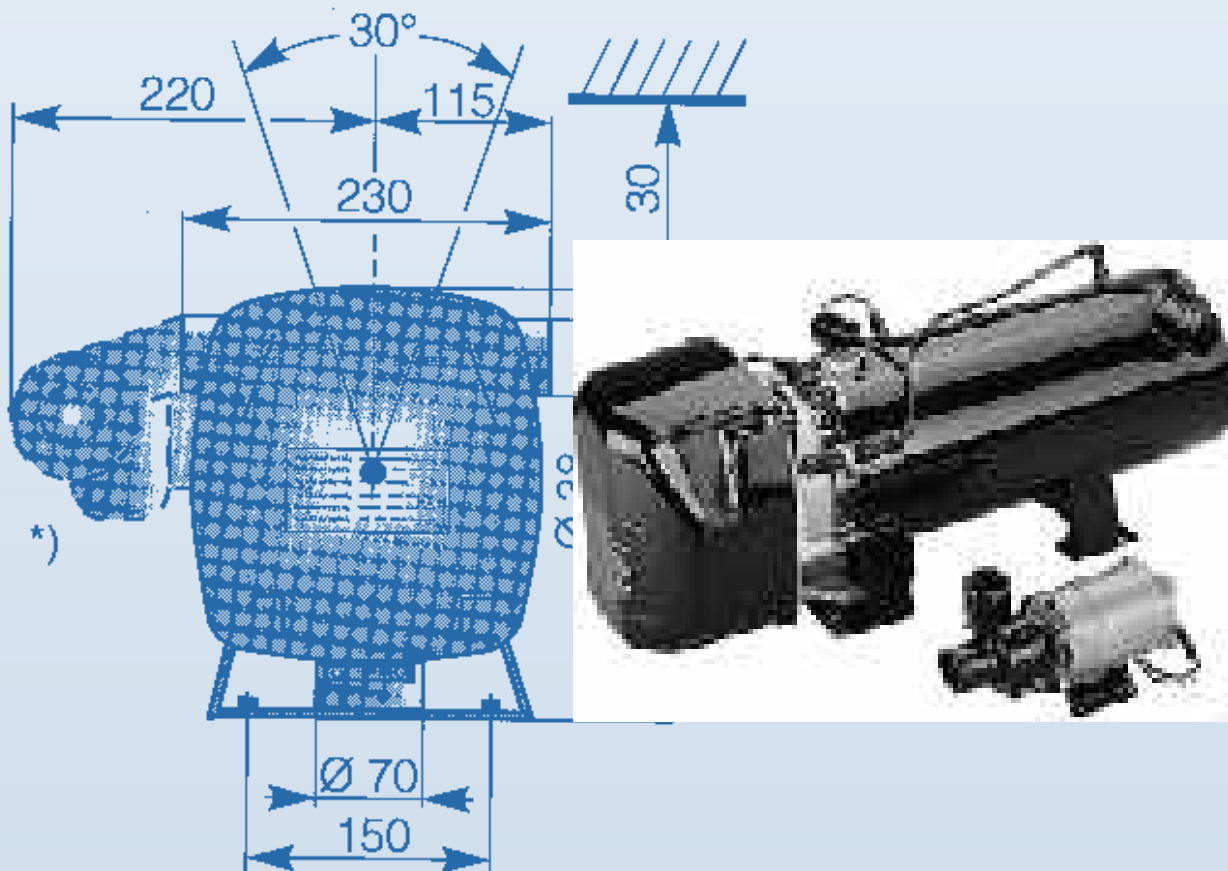

May 1997

This publication was correct at the time of going to print. However, Espar Inc. has a policy of continuous improvement and reserves the right to amend any specifications without prior notice.

Table of Contents

I. Introduction	<ol style="list-style-type: none">1. Heater Warnings2. Introduction3. Specifications4. Heater Components5. Principal Dimensions	Page 1-5
II. Installation Procedures	<ol style="list-style-type: none">1. Heater Location2. Heater Mounting3. Heater Plumbing4. Fuel System5. Electrical Connections6. Exhaust & Intake Connections7. Operating Switches	Page 5-15
III. Heater Operation	<ol style="list-style-type: none">1. Pre-Start Procedures2. Start-Up3. Running4. Switching Off5. Safety Equipment6. Operational Flow Chart7. Wiring Diagrams Model # 25 1869 01/05 25 1871 01/05 25 1870 01/05 25 1872 01/05	Page 15-19
IV. Maintenance, Troubleshooting & Repairs	<ol style="list-style-type: none">1. Recommended Periodic Maintenance2. Troubleshooting3. Fuel Quantity Test4. Adjusting the combustion air5. Dismantling the water pump6. Repair Steps	Page 20-31
VII. Heater Components	<ol style="list-style-type: none">1. Parts Diagram2. Description & Part #'s	Page 32-39

Special Notes

Note: Highlight areas requiring special attention or clarification.

Caution: *Indicates that personal injury or damage to equipment may occur unless specific guidelines are followed.*



Warning: Indicates that serious or fatal injury may result if specific guidelines are not followed.

1. Heater Warnings



Warning To Installer

- Correct installation of this heater is necessary to ensure safe and proper operation. Read and understand this manual before attempting to install the heater. **Failure to follow all these instructions could cause serious or fatal injury**



Warning - Explosion Hazard

- Heater must be turned off while re-fueling.
- Do not install heater in enclosed areas where combustible fumes may be present.
- Do not install heaters in engine compartments of gasoline powered boats.



Warning - Fire Hazard

- Install the exhaust system so it will maintain a minimum distance of 2" from any flammable or heat sensitive material.
- Ensure that the fuel system is intact and there are no leaks.



Warning - Asphyxiation Hazard

- Route the heater exhaust so that exhaust fumes cannot enter any passenger compartments.
- If running exhaust components through an enclosed compartment, ensure that it is vented to the outside.



Warning - Safety Hazard on Coolant Heaters Used With Improper Antifreeze Mixtures

- The use of Espar coolant heaters requires that the coolant in the system to be heated contain a proper mixture of water and antifreeze to prevent coolant from freezing or slushing.
- If the coolant becomes slushy or frozen, the heater's coolant pump cannot move the coolant causing a blockage of the circulating system. Once this occurs, pressure will build up rapidly in the heater and the coolant hose will either burst or blow off at the connection point to the heater.
- This situation could cause engine damage and/or personal injury. Extreme care should be taken to ensure a proper mixture of water and antifreeze is used in the coolant system.
- Refer to the engine manufacturer's or coolant manufacturer's recommendations for your specific requirements.

Note: During electrical welding work on the vehicle disconnect the power to the heater in order to protect the control unit.



2. Introduction

Espar's D24W / D30W Coolant Heater

Quality engineered to provide a dependable means of heating, the Espar D24W and D30W are diesel fired coolant heaters capable of putting out between 82,000 to 102,000 BTU's/hr.

The heater pumps coolant from the engine, heats it and returns it to the engine. By routing the hot coolant through heat exchangers it is also possible to heat the interior of the vehicle. It is also possible to route the coolant through stainless steel tubing to pre-heat hydraulic fluid and fuel in off-road applications.

Since the heater runs on diesel fuel and 24 volt power, it is able to perform this completely independently of the vehicle engine. A temperature regulating switch in the unit regulates the coolant temperature between a low of 149°F (65°C) and a high of 176°F (80°C) by automatically cycling the heater.

The D24W /D30W can be operated from the vehicle cab by an on/off

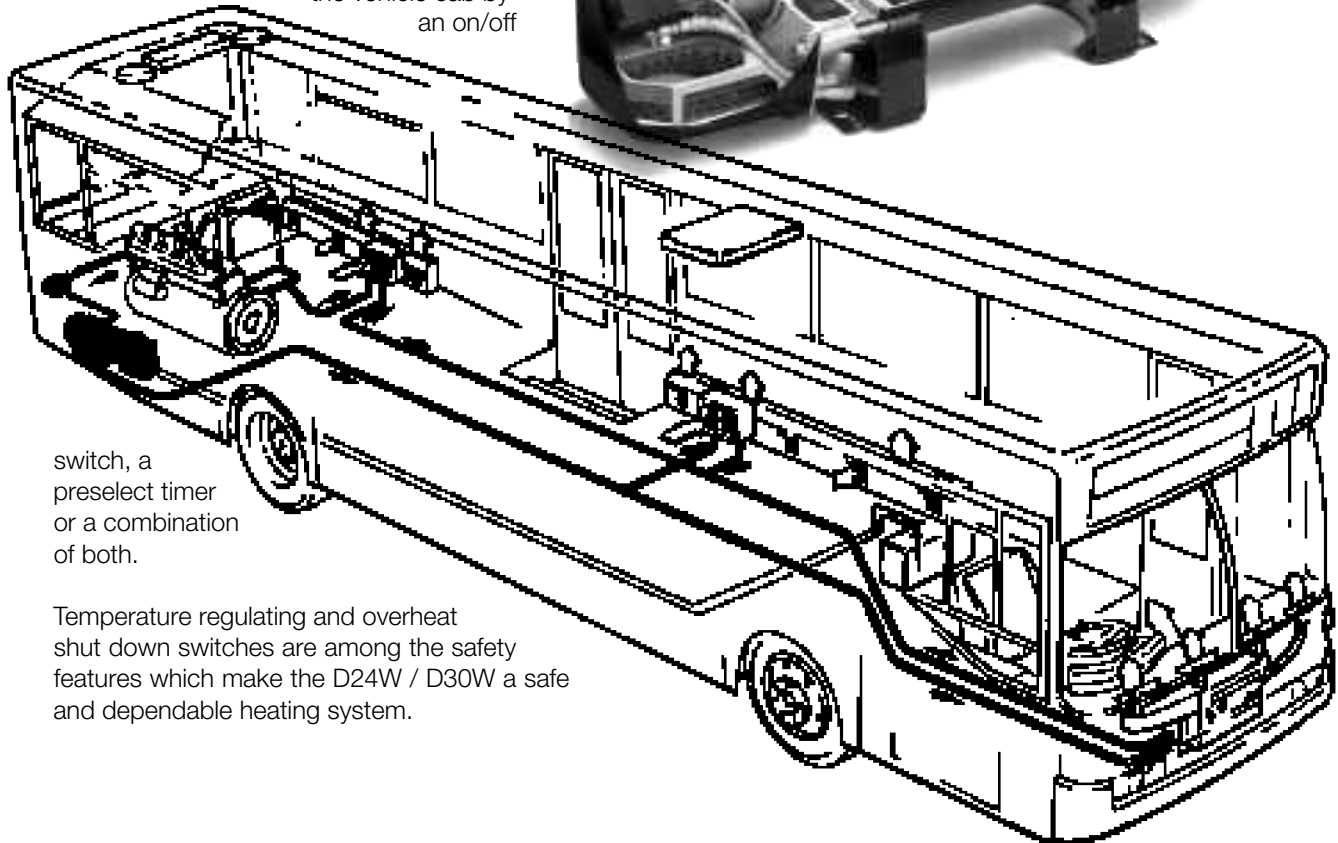

switch, a preselect timer or a combination of both.

Temperature regulating and overheat shut down switches are among the safety features which make the D24W / D30W a safe and dependable heating system.

3. Specifications - heater

Model (24V)	D24W	D30W
Heat output ($\pm 10\%$)	82,000 BTU (24Kw)	102,000 BTU (30Kw)
Current draw ($\pm 10\%$) (without water pump)	5 amps	5.5 amps
Fuel consumption ($\pm 10\%$)	2.90 l/hr (0.76 gal/hr)	3.65 l/hr (0.96 gal/hr)
Operating Voltage Range		
Minimum Voltage	20V	20V
Maximum Voltage	28V	28V
Working pressure	0.4 - 2.0 bar 6-29 psi	0.4 - 2.0 bar 6-29 psi
Water capacity	2.6 l	2.6 l
Ambient temperature (minimum)	-40°C to +70° C	-40°C to +70° C
Overheat temperature Shutdown ($\pm 5\%$)	221°F (105°C)	
Weight	55 lbs. (25 kg.)	
Controls available	On/Off switch, 99hr. timer or 7 day timer.	

Specifications - water pump

	Standard	High capacity
Voltage	24 V \pm 20%	24 V \pm 20%
Current draw	4.6 amps	10.4 amps
Water throughput	5000 l/hr - 200mbar	6000 l/hr - 200mbar

Note: The heater is equipped with a high voltage cutout as well a low voltage cutout.



4. Heater Components

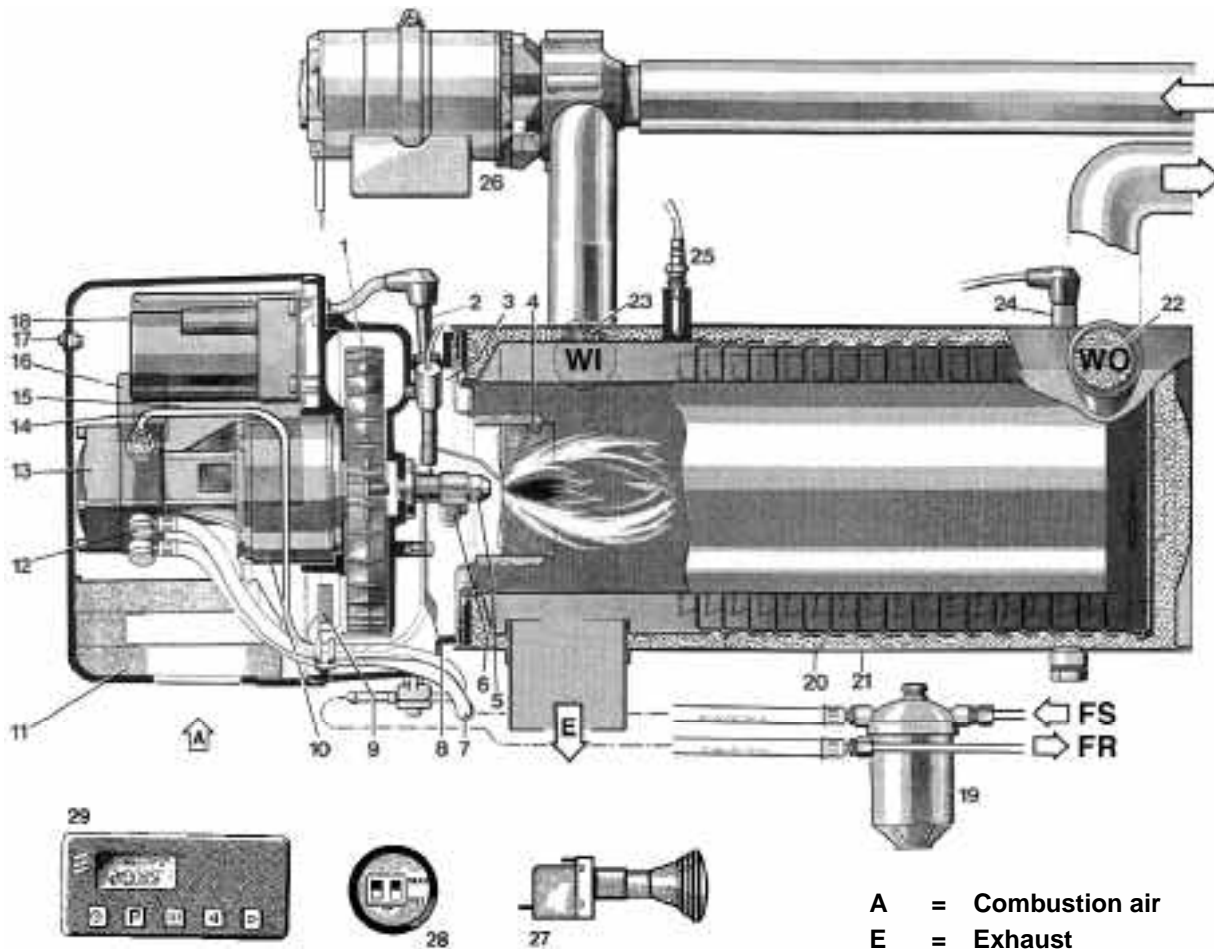

A = Combustion air
E = Exhaust
F = Fuel supply line
FR = Fuel return line
WO = Water Outlet
WI = Water Inlet

- | | | | |
|----|------------------------------------|----|----------------------------------|
| 1 | Combustion air blower wheel | 16 | Fuel solenoid valve |
| 2 | Ignition electrode | 17 | Diagnostics Display |
| 3 | Flame monitor | 18 | Ignition spark generator |
| 4 | Mixing head | 19 | Fuel filter |
| 5 | Fuel nozzle | 20 | Heat exchanger with flame pipe |
| 6 | Fuel nozzle pre heating (optional) | 21 | Outer casing |
| 7 | Fuel line | 22 | Water connection socket - outlet |
| 8 | Air baffle plate | 23 | Water connection socket - inlet |
| 9 | Combustion air control plate | 24 | Safety thermal cut-out switch |
| 10 | Electric motor | 25 | Temperature Probe |
| 11 | Silencer | 26 | Water pump |
| 12 | Fuel connection | 27 | Push/Pull switch |
| 13 | Fuel pump | 28 | 99 hr timer |
| 14 | Fuel compression line | 29 | 7 day timer |
| 15 | Control unit | | |

5. Principal Dimensions

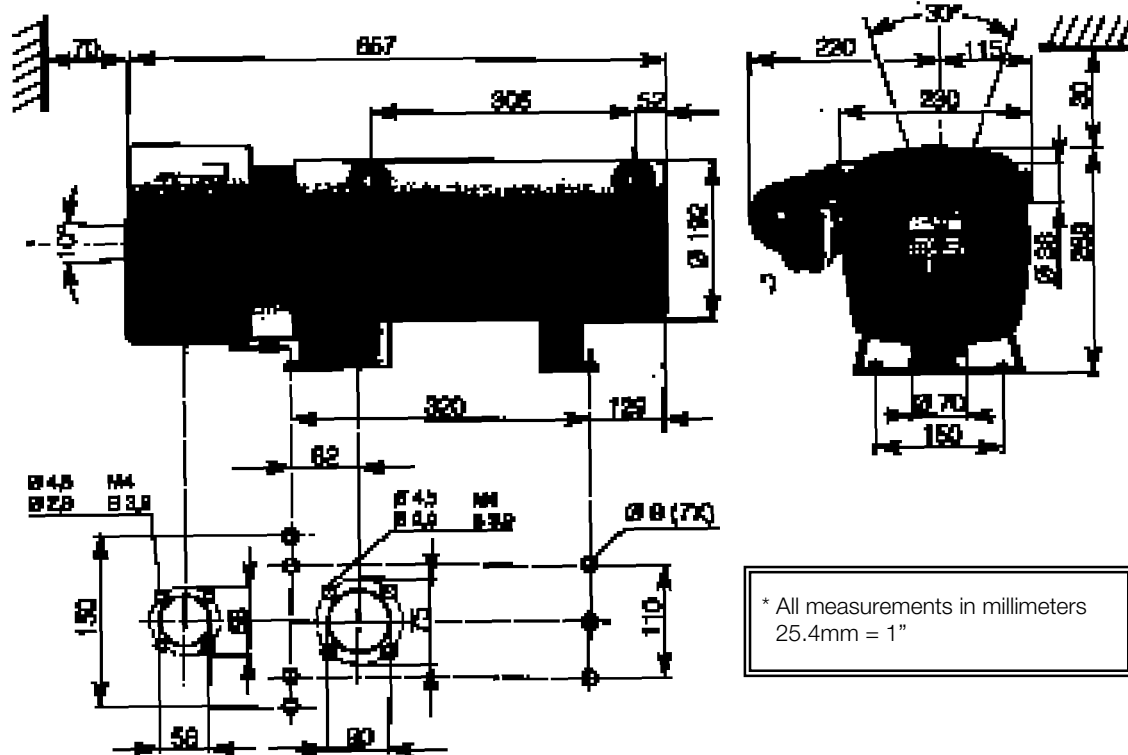

II. Installation Procedures

1. Heater Location

Mount the heater in a protected area eg: storage compartment or engine compartments. When mounting the heater adhere to the following conditions:

- Situate the heater below the normal coolant level of the engine.
- Guard against excessive road spray.
- Keep coolant hoses, fuel lines and electrical wiring as short as possible (see fuel line & electrical wiring specs on pgs.9-11)

2. Heater Mounting

Using the hole pattern shown above to mount the heater using the following mounting methods:

- Fabricate support brackets.
- Use an existing compartment floor (if available).



3. Heater Plumbing

The heater can either be incorporated into the engine's cooling system for engine preheating or can be provided with its own circulation system for space heating (ie. marine)

Engine Plumbing

To pre heat engines, follow these guidelines and refer to engine plumbing diagram shown below.

- Install fittings into the block for pick up and returns.
- Use existing holes in the engine block (ie. remove blanking plugs when possible).
- Use shut off valves to ensure the system can be isolated from the engine when not in use.
- Provide 1.5" (37.5mm) hose barbs for hose connections.
- Use 1.5" (37.5mm) hoses to ensure adequate coolant flow.

Note: The coolant must contain a minimum of 10% antifreeze at all times as a protection against corrosion. Fresh water will corrode internal heater parts.

- 1 Heater
- 2 Water pump
- 3 Shut-off valve
- 4 Engine
- 5 Radiator
- 6 Heat Exchanger
- 7 Expansion Tank
- 8 Safety valve

Isolated Circulating System

To provide space heat independent from the engine's coolant system follow these guidelines and illustrations shown.

- Provide an expansion tank
- Provide a pressure relief valve. 0.4-2.0 bars (6-29 psi)
- Ensure proper direction of coolant flow.
- Check flow rate through heater by comparing the incoming and outgoing coolant temperatures. If the rise in temperature exceeds 18°F (10°C), coolant flow must be increased by modifying plumbing.
- The heater and water pump should be installed as low as possible to allow for the purging of air.
- Use a minimum of 1.5" (37.5mm) hose to and from the heater.

- Keep the pick up and return points as far apart as possible to ensure good heat distribution.
- Take the coolant from a low point on the engine to reduce aeration in the system.
- Ensure proper direction of coolant flow by taking coolant from a high pressure point in the engine and returning it to a low pressure point. (ie. pickup from back of block and return to the suction side of the engine's water pump).
- Ensure adequate flow rate through the heater by comparing the incoming and outgoing coolant temperatures. If the rise in temperature exceeds 18°F (10°C), coolant flow must be increased by modifying the plumbing.
- Ensure the heater and water pump are installed as low as possible to allow the purging of air.
- See plumbing diagrams for alternative plumbing methods.

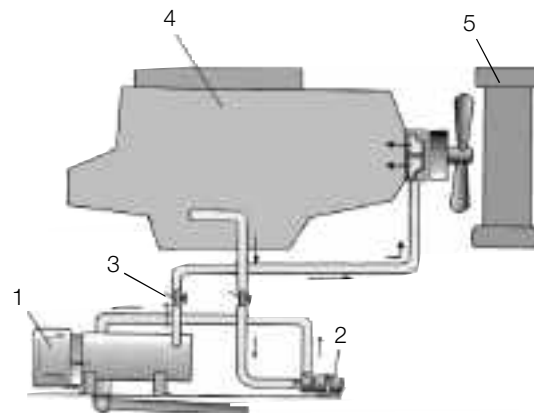

D24W / D30W plumbed for engine pre-heat

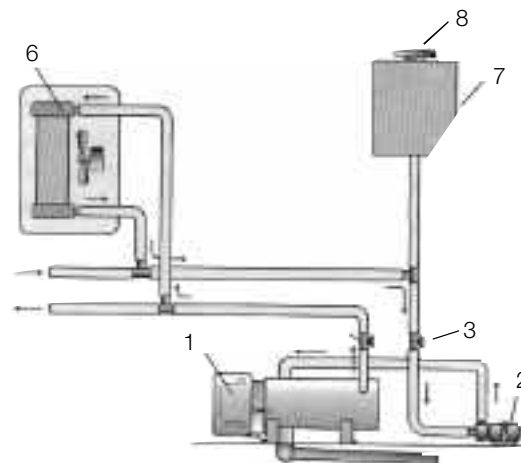

D24W / D30W plumbed in isolated circuit

Adding Heat Exchangers, Fuel warmers or Hydraulic warmers

- Maintain proper flow through heater at all times
- Provide air relief cocks at the heat exchanger.
- If the water piping cannot be run with a continuous rise to the heat exchangers, provide air relief cocks at high points.
- Connect plumbing circuits in parallel to avoid reduction of plumbing hose size and avoid restriction of flow.

- Ensure thermostat and flow control valves do not completely close off flow through heater
- Refer to plumbing diagrams for examples

Warning: Ensure that a coolant flow path is open at all times while the heater is operating to avoid overheating conditions. Failure to do so may result in bursting of coolant hoses with the release of hot coolant and steam

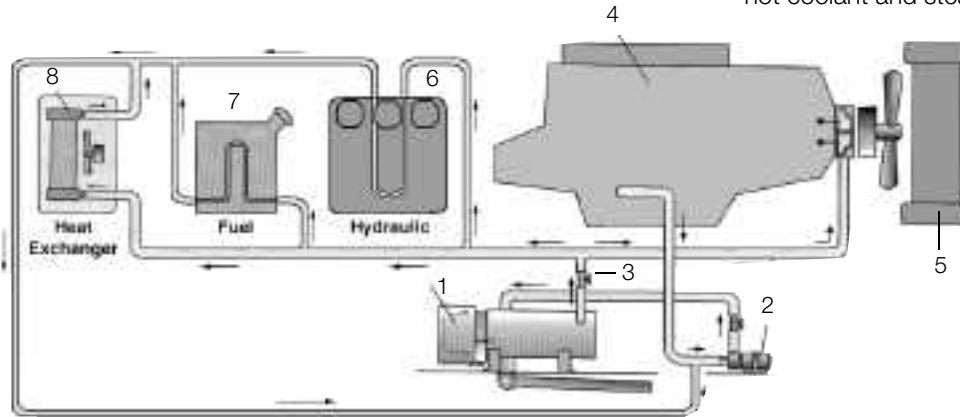

D24W / D30W plumbed for hydraulic and fuel pre-heat with heat exchanger

- | | | | |
|--------------|------------------|------------------------|------------------|
| 1 Heater | 3 Shut-off valve | 5 Radiator | 7 Fuel tank |
| 2 Water pump | 4 Engine | 6 Hydraulic fluid tank | 8 Heat exchanger |

Bus Plumbing Diagram

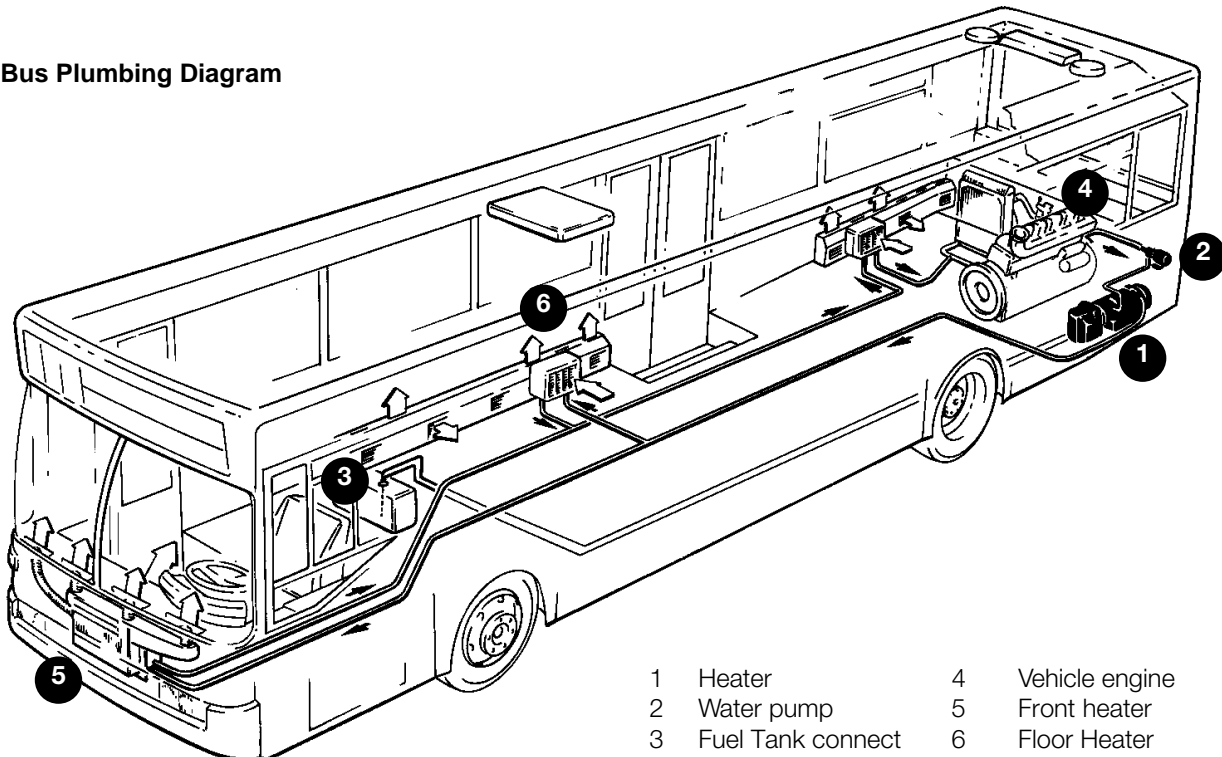

- | | |
|---------------------|------------------|
| 1 Heater | 4 Vehicle engine |
| 2 Water pump | 5 Front heater |
| 3 Fuel Tank connect | 6 Floor Heater |

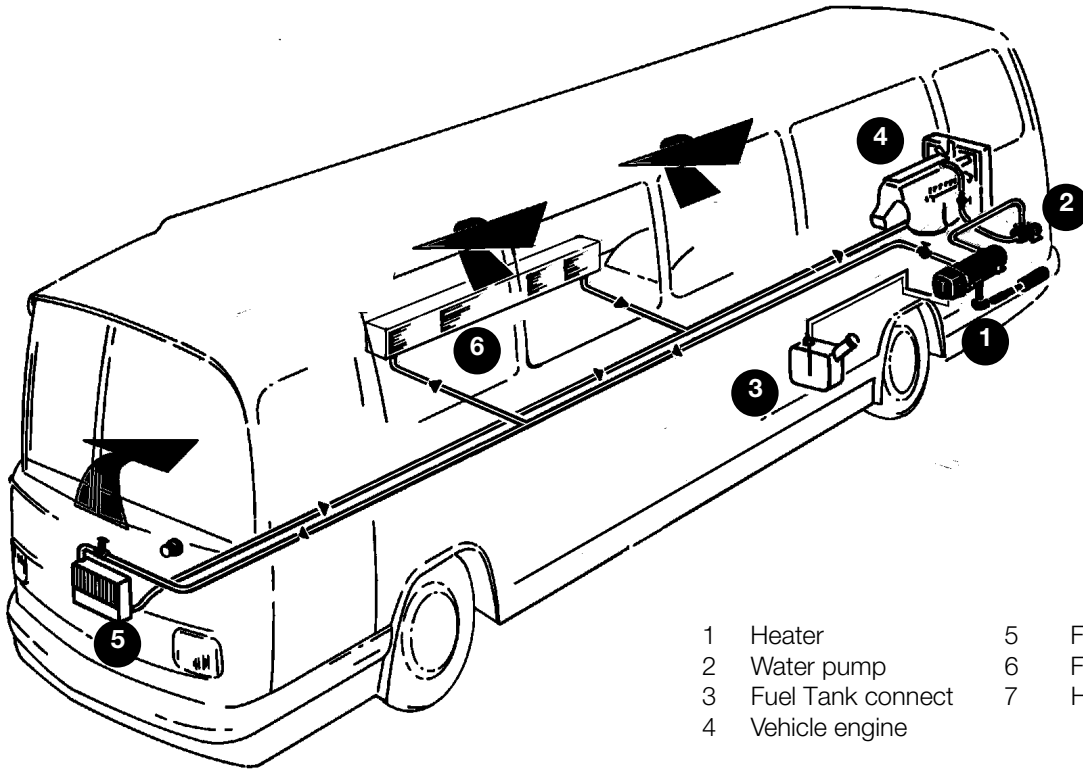

- | | | | |
|---|-------------------|---|----------------|
| 1 | Heater | 5 | Front heater |
| 2 | Water pump | 6 | Floor Heater |
| 3 | Fuel Tank connect | 7 | Hydraulic Tank |
| 4 | Vehicle engine | | |

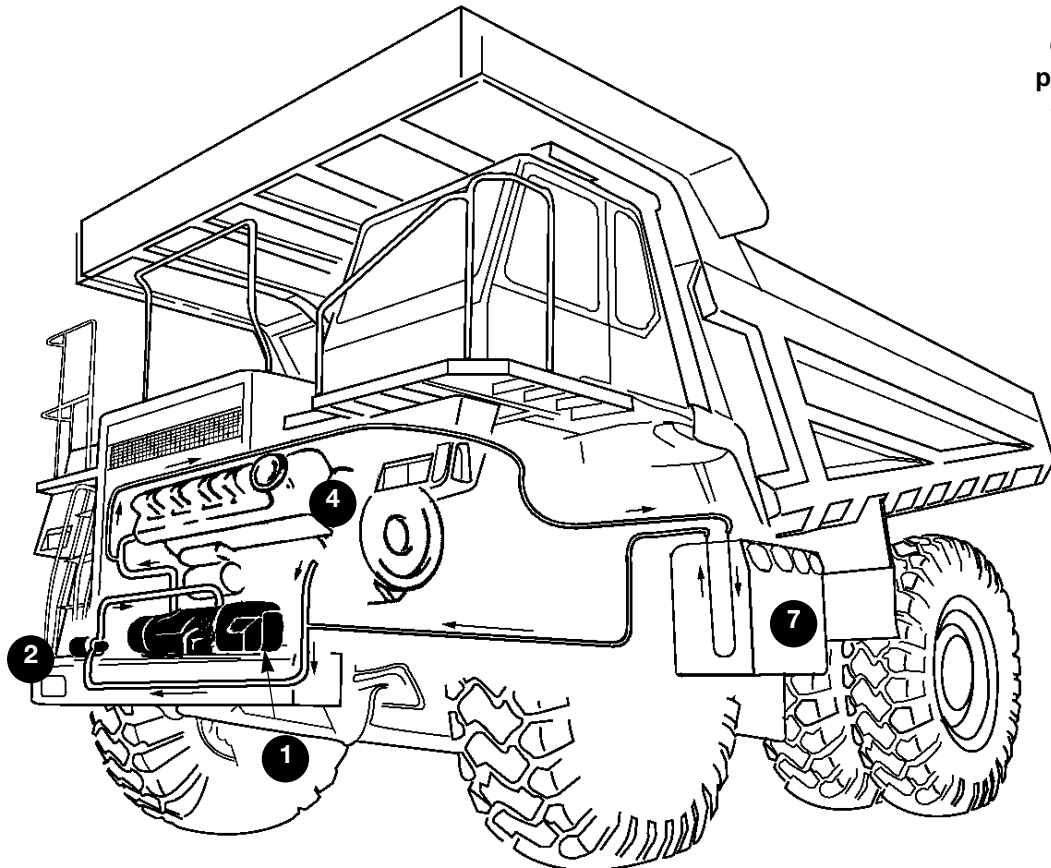

Off-road plumbing diagram

4. Fuel System

To connect the fuel supply to the heater (at the fuel filter), a supply line and a return line to the tank are necessary. To accommodate these lines at the tank, a fuel pick-up pipe with a return stem is available. The fuel filter is located into the feed line near the heater. It is recommended that a shut off valve be fitted near the heater on both the intake and return lines. (fuel filter and shut off valves are already attached to the heater in the compact version). Refer to Figures below for connections and specifications.

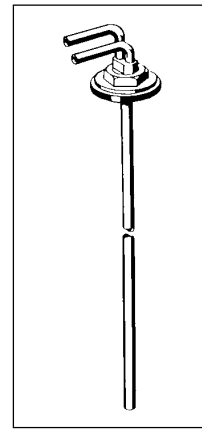

Fuel pick up pipe with return

Fuel System Tolerances

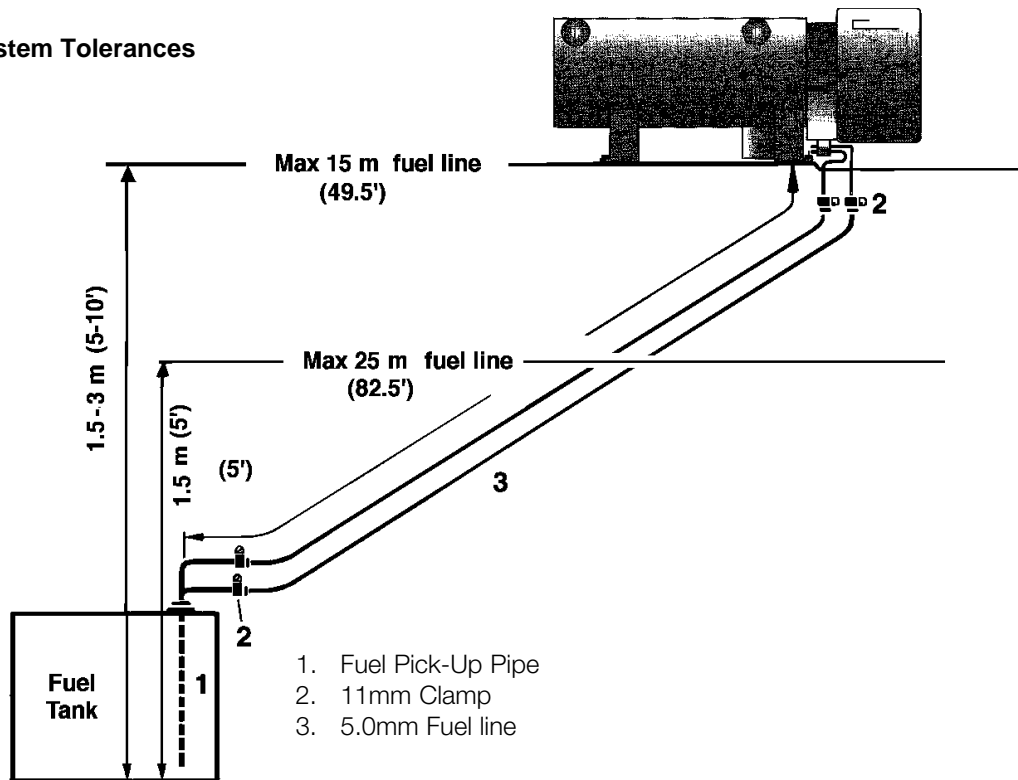

S = Fuel Supply
R = Return fuel

If the D24W / D30W heater is situated within 1.5 m (5') above the fuel tank, a permissible 25 meters (82.5') of fuel line can be used.

If it is between 5 -10' (1.5 - 3 m) above the fuel tank a maximum fuel line of 15 m (48.5') is permissible.





Fuel Pick-Up Pipe Installation (Standard Pick-Up)

Choose a protected mounting location close to the pump and heater. A spare fuel sender gauge plate provides an ideal mounting location.

- Drill the mounting holes as shown in Figure 1.
- Cut the fuel pick-up pipe to length.
- Mount the fuel pick-up pipe as shown in Figure 2.
- Lower the fuel pick-up pipe (with reinforcing washer) into the tank using the slot created by the two 1/4" holes.
- Lift the assembly into position through the 1" hole.
- Assemble the rubber washer, metal cup washer and nut.

Note: Drill the two 1/4" holes first.

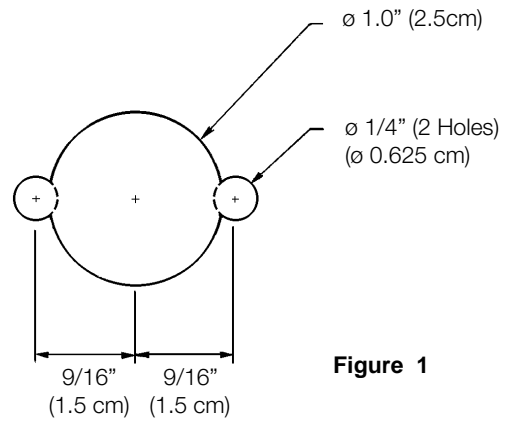

Figure 1

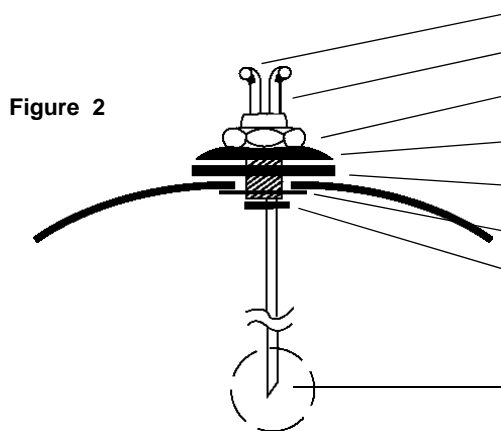

Figure 2

Fuel Pick-Up Pipe Return

Fuel Pick-Up Pipe Supply

Nut

Sheet Metal Washer

Rubber Gasket

Steel Safety Washer

Holding Tabs

Allow 4" from fuel pick-up to tank bottom.

Allow only 1" for flat bottom tanks.

End tip of the fuel pick-up pipe should have angle so as to avoid picking up dirt and subsequent blockage.

5. Electrical Connections

Caution: To avoid potential short circuit damage during installation, make connection to the positive terminal at battery after all electrical connections are complete.

- A. Power/ Pump Harness**
- 3 core harness (red, red, brown).
 - Connect red wires to vehicle battery (+) via fuse link provided, using ring terminal provided.
 - Connect brown wire to vehicle battery (-) using ring terminal provided.

- B. Switch Harness**
- 3 core harness (red, brown, yellow).
 - Run to location of switch.

- C. Main Heater Harness**
- Connects the above harnesses to control unit and other components inside the heater cover.

- D. Pump Harness Extension**
- 2 core harness (red, brown)
 - Connects to pump and main heater harness (Universal model only)

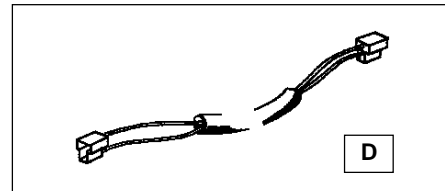

Universal model

Compact version

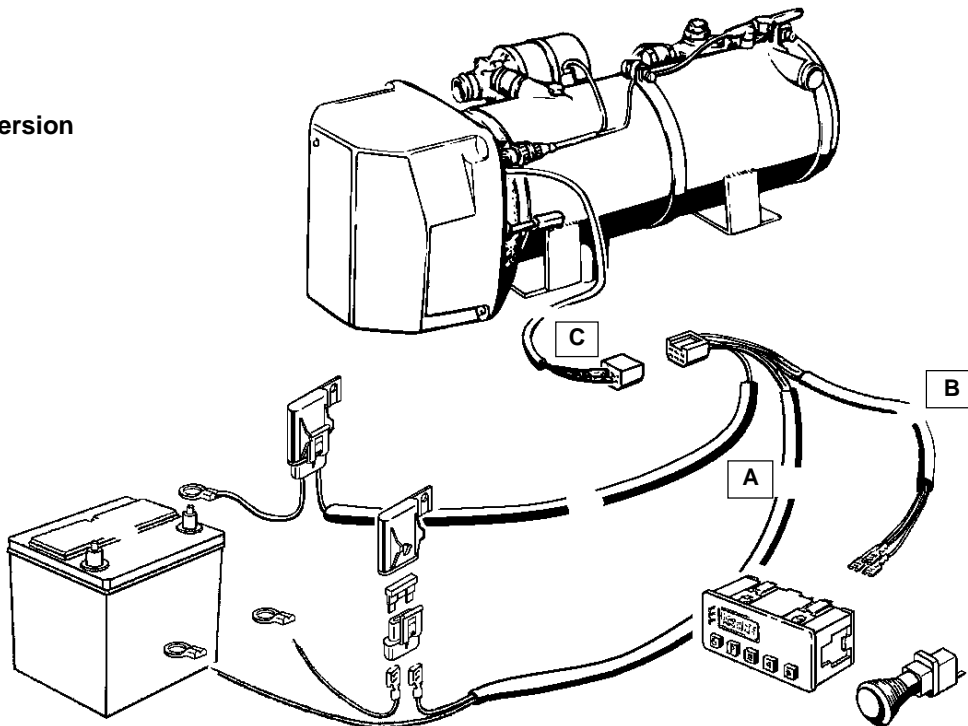

Note: All harnesses should be cut to length. All exposed electrical connections should be coated with protective grease.



6. Exhaust Connection

A 2.8" (70 mm) flexible tube exhaust pipe with a length no more than 4m long is required for the exhaust. A 3" (75mm) muffler clamp is needed to secure the exhaust to the the heater. Connect the exhaust as follows:

- Connect the exhaust pipe to the exhaust tube on the heater and attach with clamp provided.
- Run exhaust to an open area to the rear or side of the vehicle so that fumes can not build up and enter the passenger compartment or the heater combustion air intake.
- Install exhaust pipe with a slight slope or drill a small hole in the lowest point to allow water to run off. Any restriction in exhaust will cause operational problems.
- Secure the exhaust pipe at the heater using clamps and holders. Secure the exhaust pipe externally using clamps and holders.

Caution: Run exhaust so that it cannot be plugged by dirt, water or snow. Ensure the outlet does not face into the vehicle slip stream.

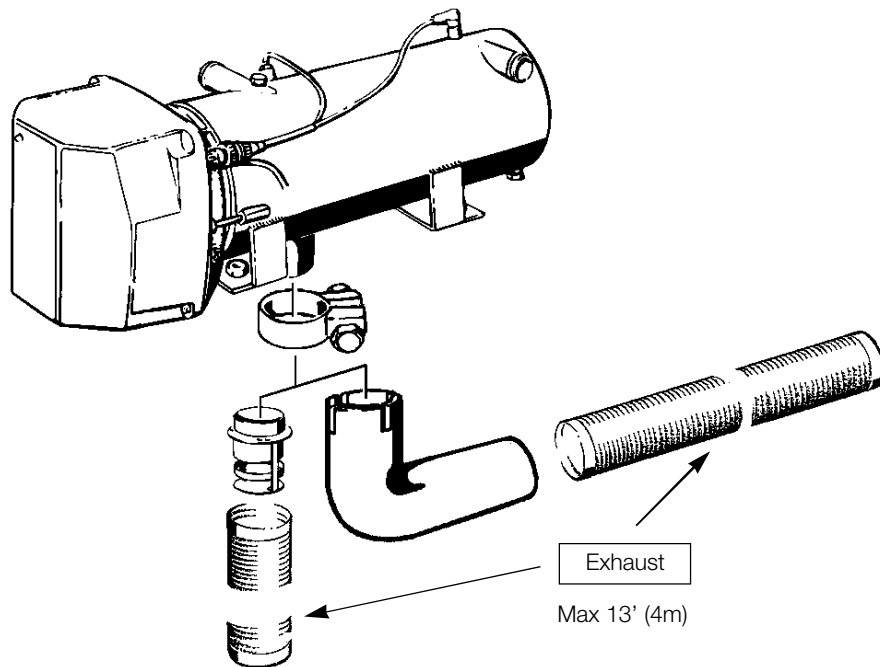

Intake Connection

The combustion air must be drawn in from the outside. The combustion air opening must be kept free at all times. When installing the heater in a closed box care must be taken to ensure that it is sufficiently ventilated from the outside. Use a louvered type plate or grill.

Caution: - Do not install the intake opening facing the vehicle slipstream, ensure that the opening cannot become clogged with dirt or snow and that any water entering the intake can drain away.

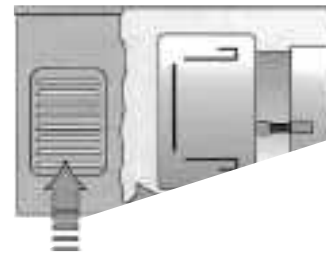

WARNING: The exhaust is hot, keep a minimum of 2" clearance from any heat sensitive material. Route exhaust so that the exhaust fumes cannot enter the passenger compartment.

7. Operating Switches

A Push/Pull switch, optional 99 Hour Digital Timer or a 7 Day Timer are available for the heater. Connect the operating switch as follows.

Push/Pull Switch

- Mount switch in a location where it is easily accessible.
- Mount using hardware supplied.
- Connect the 25' switch harness to the connector at the heater and run the harness to the switch location.
- Cut harness to length at the switch and install terminals.
- Connect wiring as shown in Figure 3.

Note: Wired as above the switch light glows when pulled out and is off when pushed in.

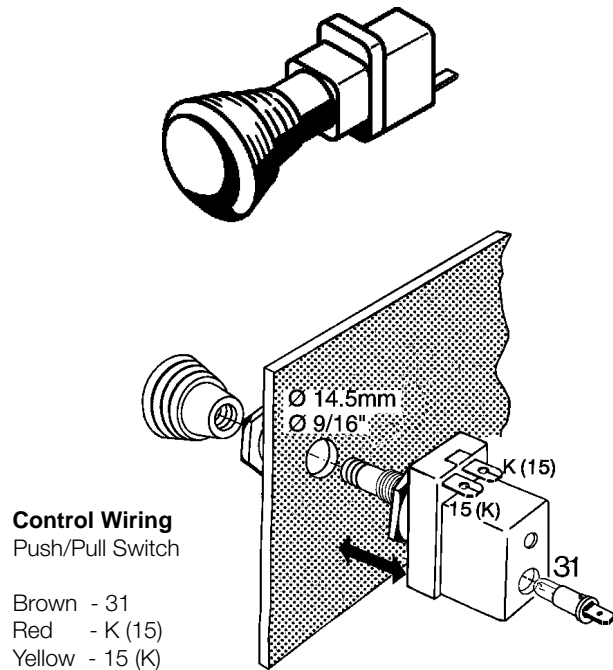
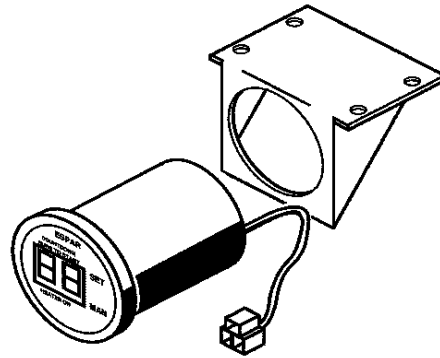

Figure 3

99 Hour Digital Timer

This timer is pre-set by Espar to operate the heater for one (1) hour only. If an alternative run time setting is desired refer to the instructions provided with the timer.

- Mount the timer using a 2" hole in the dash or use the optional mounting bracket.
- Mount timer using hardware supplied.
- Connect the 25' switch harness to the connector at the heater and run the harness to the switch location.
- Cut harness to length and terminate wires.
- Attach using connector provided.
Red-Red
Yellow-Yellow
Brown-Brown





7 Day Timer

The 7 day timer is capable of setting up to 3 preset start times within 24 hrs. or 1 start time within 7 days. It also has other functions such as a current time display and a heater numeric fault code. Refer to instructions provided with timer for setting options.

- Mount timer and bracket in a suitable location.
- Connect the 25' switch harness to the connector at the heater and run the harness to the switch location.
- Cut harness to length at the switch and install terminal.
- Connect switch harness to timer....Figure 4
- Refer to timer instructions for other wiring options.

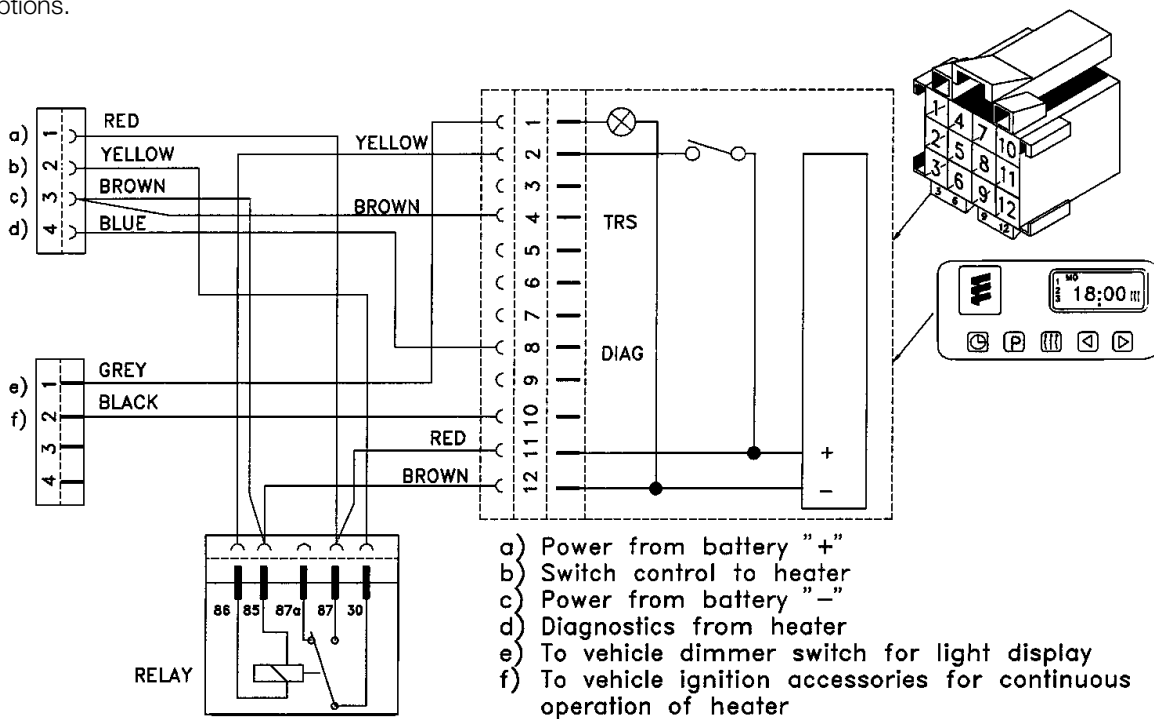
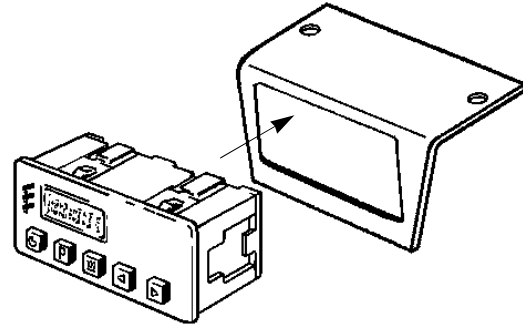

Figure 4

Note: The timer display is automatically illuminated while the heater is operating. Connecting the grey wire to the vehicle dimmer switch will allow the timer display to illuminate with the vehicles dash lights. An alternative to connecting the black wire to the vehicle ignition accessories "On" circuit may also be considered for some applications where extended run times are desired. Connecting the black wire with the red wire will enable the heater to run continuously whether the heater is switched on manually or through the preset function.

III. Heater Operation

1. Pre-Start Procedures

Upon completion of installation prepare the heater as follows:

- Check all fuel, electrical and plumbing connections.
- Refill the engine coolant
- Bleed air from the coolant system by loosening the locking screw on the coolant inlet barb.
- Re-tighten screw
- Run engine to further bleed the system.
- Top up engine coolant.

2. Start Up

Once switched on the following sequence occurs:

- Control unit does a systems check (flame sensor, temperature, safety thermal cutout fuse and various other control unit checks).
- Water pump starts circulating coolant fluid.
- Electric motor starts the combustion air blower and fuel pump.
- A motor system test is performed and the electric motor is shut off while the control unit measures the generated voltage.
- Fuel solenoid opens enabling fuel to be sprayed into the combustion chamber.
- Atomized fuel is then ignited by a high voltage ignition spark.
- Once ignition takes place a photoresistive cell automatically switches the ignition system off (ignition time: 10 seconds maximum).

3. Running

Once ignition is successful the following operations take place:

- Heater runs in full heat mode and the temperature is monitored at the heat exchanger.
- If the temperature rises above 80°C(176°F) the heater automatically switches itself off.
- The water pump continues to circulate coolant to allow the heater to monitor engine temperature.
- When the temperature drops below 65°C(149°F) the heater will cycle itself back on automatically.
- The heater continues to run as described above until it is switched off, either manually, automatically by a timer or heater malfunction shutdown.
- The set value of the water temperature is adjusted in the control unit. If a temperature reducer is connected the control temperature is reduced by approx. 8°C. (see wiring diagram)

4. Switching Off

- When the heater is switched off the fuel solenoid valve closes, shutting off the fuel supply.
- The flame is extinguished and a switch off lag time begins. (2 1/2-3min.)
- The combustion air blower and water pump continue to run for a three minute cool down cycle clearing residual combustion gases and drawing heat off the heat exchanger preventing any local overheating.
- After the three minute cool down the heater shuts off.

Note: If the heater fails to start the first time it will automatically attempt a second start. If unsuccessful the heater will shut down completely.

Note: On initial start up the heater may require several start attempts to self prime the fuel system.

Note: During operation the heater continually senses the input voltage from the batteries, if the input voltage drops to approximately 20 volts or rises above 30 volts the heater will automatically shut down.















5. Safety Equipment

The control unit, overheat switch and flame sensor (photoresistive cell) continually monitor heater functions and will shut down the heater in case of a malfunction.

- The control unit ensures electrical circuits (fuel pump, combustion air blower etc.) are complete prior to starting the heater.
- If the heater fails to ignite within 10 seconds of the fuel solenoid opening, a “no start safety shutdown” follows.
- If the heater flames out during operation, the heater automatically attempts to restart. If the heater fails to ignite within 10 seconds of fuel delivery, or ignites but flames out again within 3 minutes, “flame out” shutdown follows.
- Overheating due to lack of water, a restriction or a poorly bled coolant system results in the overheat cutout fuse tripping. Fuel delivery will cease and an “overheat shut down” follows.
- If at any time the voltage drops below 20V, or rises above 30V, a “high/low voltage” shutdown follows (after a 20 second delay).



6. Operational Flow Chart

		STARTING PHASE				RUNNING PHASE		SHUT DOWN PHASE	
     	Emergency stop	Off	Optional Pre-heat	Off	Off	Off	Off	Off	Off
	Start	Off	Off	On	On	On	On	On	On
	Stop	Off	Off	Off	Off	Off	Off	Off	Off
	Emergency stop	Off	Off	Off	Off	Off	Off	Off	Off
	Start	Off	Off	Off	Off	Off	Off	Off	Off
     		30 sec.							



Wiring Diagram (no nozzle pre-heat)

D24W
model #'s

D30W
model #'s

25 1869 01 00 00
25 1869 05 00 00 (c)

25 1871 01 00 00
25 1871 05 00 00 (c)

(c) compact

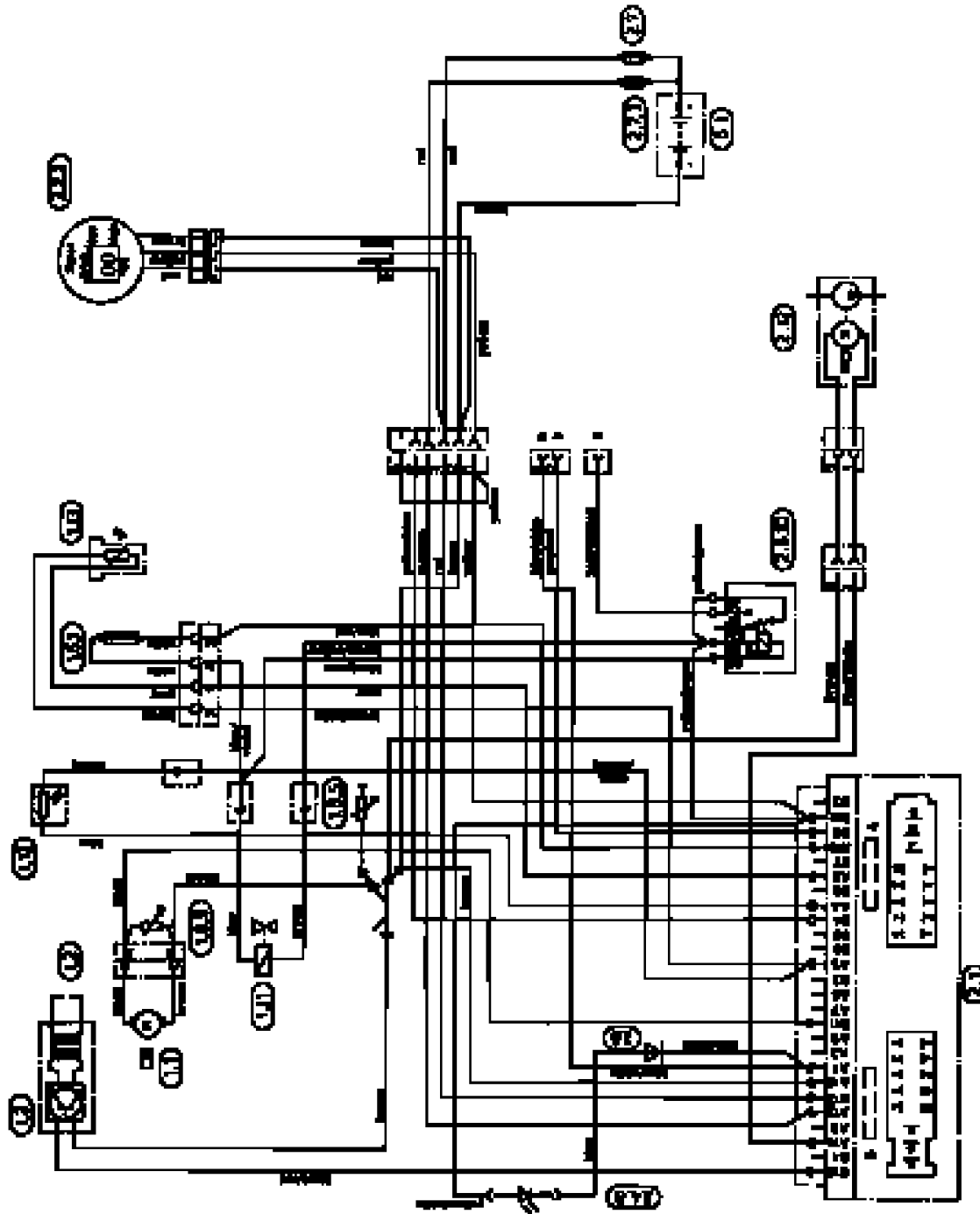

- | | | | | | | | |
|-------|--------------------------|--------|-----------------------|-------|------------------------|----|-------------------------------------|
| 1.1 | Burner motor | 1.12 | Flame sensor | 2.7.3 | Water pump fuse 10 amp | a) | External diagnostics |
| 1.2 | Ignition electrodes | 1.13 | Temperature sensor | 2.12 | Water pump | b) | apply (+) for temperature reduction |
| 1.3 | Ignition spark generator | 2.1 | Control unit | 3.2.2 | 99 Hr. Timer | c) | Combustion pilot light |
| 1.5.1 | Overheat fuse | 2.5.10 | Relay, burner display | 3.4.8 | Diagnostic light | | |
| 1.8.5 | Varistor | 2.6 | Diode | 5.1 | Battery | | |
| 1.11 | Fuel solenoid valve | 2.7 | Main fuse 25 amp | | | | |

Wiring Diagram (with fuel nozzle preheat)

D24W model #'s	D30W model #'s	
25 1870 01 00 00	25 1872 01 00 00	
25 1870 05 00 00 (c)	25 1872 05 00 00 (c)	(c) compact

- | | | | | | | | |
|-------|--------------------------|--------|-----------------------|-------|------------------------|-----|-------------------------------------|
| 1.1 | Burner motor | 1.12 | Flame sensor | 2.7 | Main fuse 25 amp | 5.1 | Battery |
| 1.2 | Ignition electrodes | 1.13 | Temperature sensor | 2.7.3 | Water pump fuse 10 amp | a) | External diagnostics |
| 1.3 | Ignition spark generator | 1.14 | Fuel nozzle pre heat | 2.12 | Water pump | b) | apply (+) for temperature reduction |
| 1.5.1 | Overheat fuse | 2.1 | Control unit | 3.1.5 | Switch, water pump | c) | Combustion pilot light |
| 1.8.5 | Varistor | 2.5.10 | Relay, burner display | 3.4.1 | Start control | | |
| 1.11 | Fuel solenoid valve | 2.6 | Diode | 3.4.8 | Diagnostic light | | |

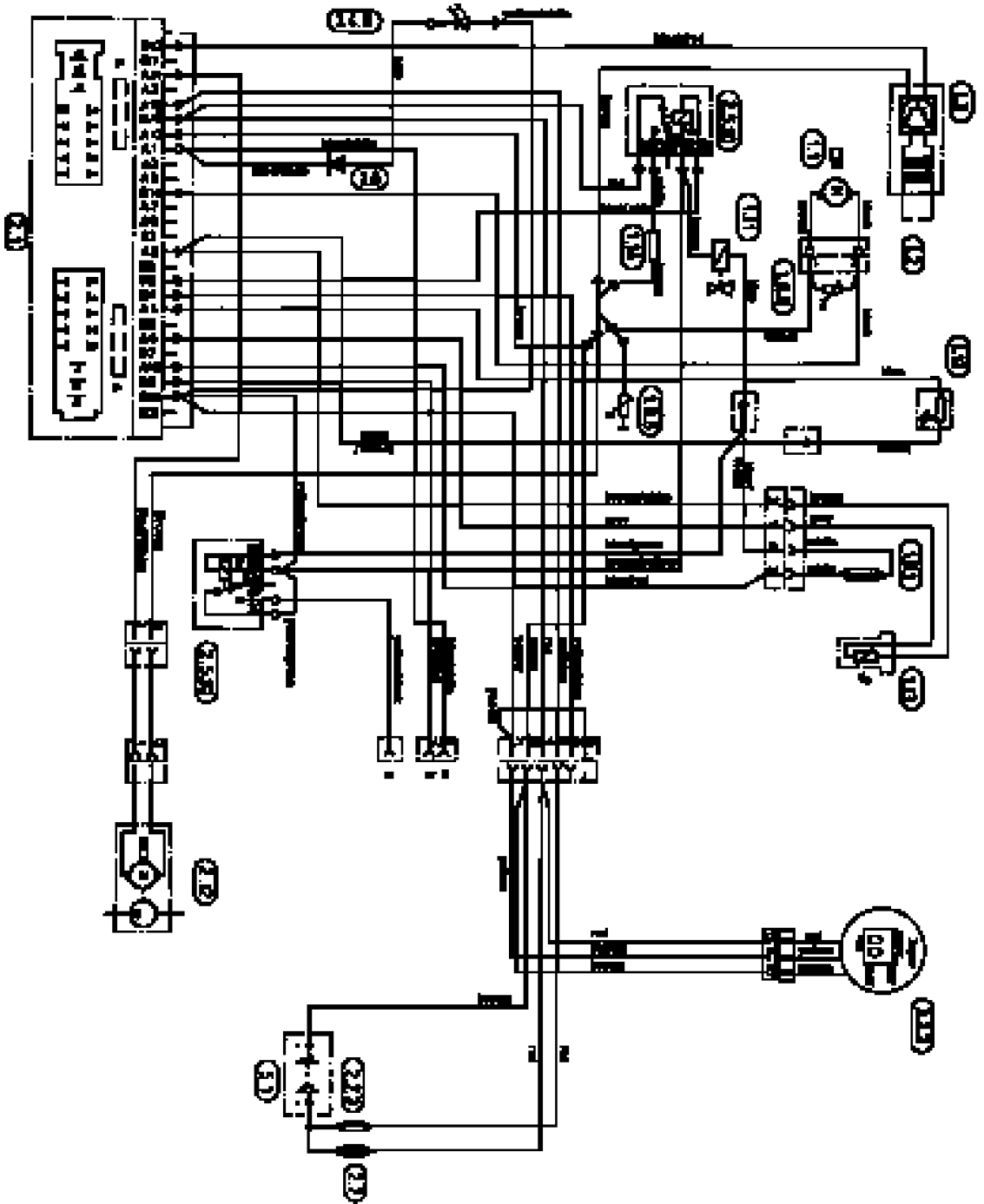



IV. Maintenance Troubleshooting & Repairs

1. Recommended Periodic Maintenance











- Check coolant hoses, clamps, and make sure all valves are open. Maintain the engine manufacturers recommended coolant level and ensure that the heater is properly bled after service on or involving the coolant system.
- Visual check of all fuel lines for leaks. Check and if necessary replace fuel filter inserts.
- Check and if necessary replace gaskets on ignition electrodes.
- Visual check of electrical lines and connections for corrosion.
- Check and if necessary clean photoresistive cell.
- Run your heater at least once a month during the year (for a minimum of 15 minutes).
- Maintain your batteries and all electrical connections in good condition. With insufficient power the heater will not start. Low and high voltage cutouts will shut the heater down automatically.
- Use fuel suitable for the climate (see engine manufacturers recommendations). Blending used engine oil with diesel fuel is not permitted.

2. Troubleshooting













Basic Troubleshooting

In the event of failure there are several items which should be checked first before any major troubleshooting is done.

- Check
- Circuit breakers and Fuses.
 - Electrical lines and connections
 - For interference in Combustion air and Exhaust pipes.
 - That there is fuel in the tank.
 - Battery voltage

Fault Code		Fault description	Indication		Remedy
			Fault signal/flashing code		
000	No fault				
001	Pre-heating, overvoltage				Check control unit. Charge battery
002	Pre-heating, under voltage				Charge battery.
010	Overvoltage switch-off				Check control unit. Check battery charge. Connect heater directly to the battery.
011	Under voltage switch-off				Charge battery, Check control unit. Check cross sections of power leads.
012	Overheating				Check electric lines, connections and function of safety thermal cutout fuse and relay burner display; check water flow; check water pump and if necessary replace; check leads and connections to fuel solenoid.
025	Short circuit at diagnostic output		No flashing code		Check diagnosis lead Check connection to control unit.
032 033	Burner motor				Check combustion air fan. Replace if necessary. Check motor and connections to motor-power consumption approx. 140W, speed 3000-3250 rpm. Check connections to control unit.
047	Short circuit at fuel solenoid valve or relay coil at burner				Check electrical lines and connections to control unit. Check solenoid valve and burner relay.
051	Photoresistor defect				Check flame monitor-bright <30kΩ, dark >100kΩ Clean photoresistor or replace.
052	Failure to start/safety time expired				No flame was detected during the start up phase . Check the fuel supply & wiring to solenoid Check exhaust & combustion air piping. Check and if necessary replace ignition spark generator and relay for ignition generator; check and if necessary replace ignition electrodes; clean photoresistor. continued....



Fault Code	Fault description	Indication		Remedy
			Fault signal/flashing code	
053	Flame goes out during operation/ Too many repeated starts			Heater has started (flame detected) and indicates flame loss in power setting. Check fuel flow rate, blower speed (3000-3650rpm), fuel supply, exhaust pipe and combustion air piping. If combustion is O.K, check photoresistor, replace if necessary.
059	Water temperature rises too quickly			Check water circulation and temperature control sensor. Check water pump
060	Interruption in temperature sensor			Measured temperature lies outside measuring range. Check sensor. Check connections to temperature probe, connections to control unit, check plug type connections at relay. Test values-20°C=2000Ω, 65°C=2700Ω
061	Short circuit in temperature sensor			Measured temperature lies outside measuring range. Check sensor. Check connections to control unit
064	Interruption in flame sensor		No flashing code	
065	Short circuit in temperature sensor			
090 092 093 094 095 096	Control unit faulty			Replace control unit
097	Control unit defect or cable harness fault			Check and if necessary replace control unit. Check cable harness.
091	External interference voltage		 	Check voltage supply. Check connection to control unit



Troubleshooting without diagnostic system

Fault →

Cause ↓

Cause	Fan does not start					Check	Remedy
	Heater does not ignite, cuts out automatically						
Fault	Heater gives off soot					Check	Remedy
	Heater ignites and cuts out automatically						
Cause	Heater switched off by safety thermal cutout or temperature probe					Check	Remedy
	Heater smokes during starting and delayed shutoff						
Fault	Heater causes mechanical noises or motor speed to low					Check	Remedy
Safety thermal cutout switch has triggered	○				○	Check switch off heater, check water flow' D24W=2000l/h, D30W=2500l/h Max. temperature difference between water inlet and water outlet at heater approx. 10°C	Bleed water circulation system, check for proper flow; Check safety thermal cutout fuse
Safety thermal cutout switch faulty	○					Visual check/continuity check	Replace safety thermal cutout switch
Temperature probe faulty	○	○				Visual Check/continuity check 20°C=2000 , 65°C=2700	Replace temperature probe
Control unit faulty	○	○				No positive applied to electric motor, if so no positive applied to solenoid valve	Replace control unit
Electric motor faulty	○		○		○	Is positive applied to electric motor? If so.....	Replace electric motor
Ignition spark generator faulty		○				Is positive applied to ignition spark generator?..... No positive applied to ignition spark generator?....	If so-replace ignition spark generator Replace control unit
Mixing head coked		○	○			Visual check	Clean mixing head
Ignition electrodes faulty		○				Visual check; check electrode gap	Replace electrodes and adjust gap
Lack of fuel		○	○			Visual check of fuel lines and connections	Repair fuel lines and connections
Fuel pump sluggish, faulty		○			○	Visual check/functional check fuel return line constricted	Replace fuel pump, repair fuel line
Fuel nozzle clogged, bad (sometimes excess fuel)		○	○			Visual check	Replace atomizer nozzle
Solenoid valve does not open		○				Functional test	Replace fuel pump
Too much fuel being pumped			○			Fuel line constricted, measure fuel quantity	Repair fuel return line; adjust fuel quantity
Too little combustion air			○		○	Measure CO ₂ (24V: approx. 10.5%); Measure motor speed (3000-3650rpm; power consumption approx. 140W); Air intake or exhaust pipe blocked, fan gap too wide	Adjust combustion air, replace electric motor, remove blockage, adjust fan gap
Gaskets on flame monitor, ignition electrodes, burner and heat exchanger leaking			○			Visual check	Tighten nuts and bolts, replace gaskets if necessary, press down lock washers of ignition electrodes
Photoresistive cell faulty			○			Visual check/functional check (bright <30k , dark > 100k)	Clean flame probe, replace if necessary
Water pump faulty, too little water being pumped				○		Temperature difference water inlet and water outlet at heater > 10°C, water circulation system closed	Replace water pump, check water circulation system valves
Ball bearing of electric motor faulty					○	_____	Replace electric motor
Combustion air impeller catching	○	○			○	_____	Adjust gap between combustion air and burner casing
Solenoid valve not tight					○	Functional test	Replace fuel pump
Coupling half faulty					○	Visual check	Replace coupling half

3. Fuel Quantity Test

The fuel Quantity should be tested if the heater has difficulty starting or maintaining a flame.

Note: Measure the fuel quantity when the battery is sufficiently charged. At least 22V and at most 26V should be applied at the control unit during measurement.

A.Preparation

- Apparatus:- measuring glass, stop watch, ϕ 6mm hose.
- Close shut off valve at fuel pump.
- Switch on heater and run until remaining fuel has been consumed.
- Disconnect fuel supply and return lines from heater
- Connect fuel hose to heater and bleed pipe as shown.
- Place pipe into measuring glass with fuel.
- Start heater briefly to fill fuel lines.
- Switch on heater and measure withdrawal time for 50cm³.
- Compare measurement with figures in following table, adjust fuel quantity if necessary.

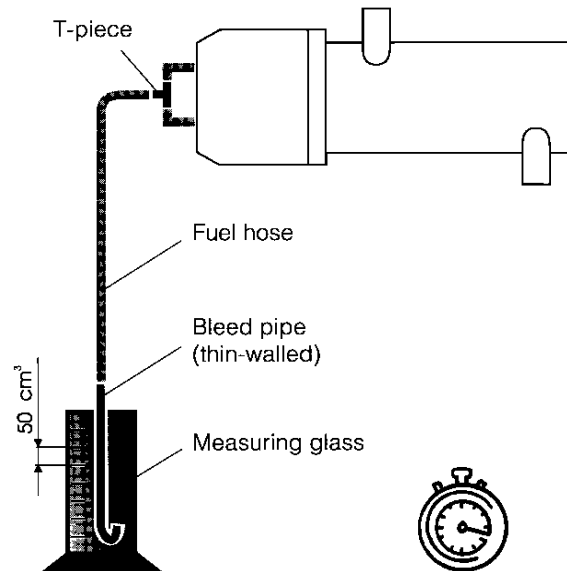

	Fuel consumption at rated voltage 24V	With drawl time for 50cm ³
D24 W	2.90 l/hr (96.7 fl.oz)	62 sec. +3
D30 W	3.65 l/hr (121.7 fl.oz)	49 sec. +3

Adjusting the fuel quantity

If the fuel quantity is too high (withdrawal time too short), release locknut and reduce fuel quantity by turning adjusting screw anti clockwise.

If the fuel quantity is too low (withdrawal time too short), release locknut and increase fuel quantity by turning adjusting screw a clockwise.

1. Adjusting screw

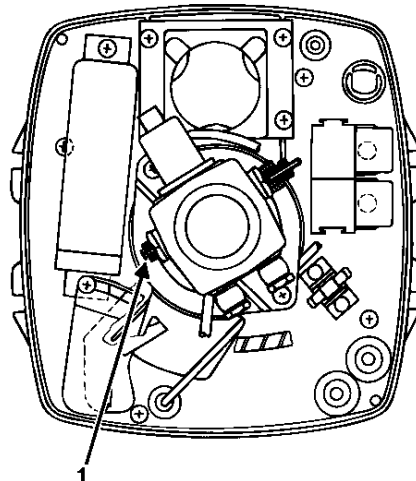



4. Adjusting combustion air

Measuring the CO₂ content

The combustion air quantity is determined by the CO₂ content depending on the voltage. To perform a correct measurement of the CO₂ content in the exhaust the heater must have reached its operating temperature and the fuel quantity must be within the permitted tolerances.

- Measure voltage at the heater
- Measure CO₂ content with a CO₂ indicator, pay attention to the manufacturer's instructions.
- Transfer both figures to the graph. If the point of intersection is outside the hatched area the combustion air gap has to be adjusted.

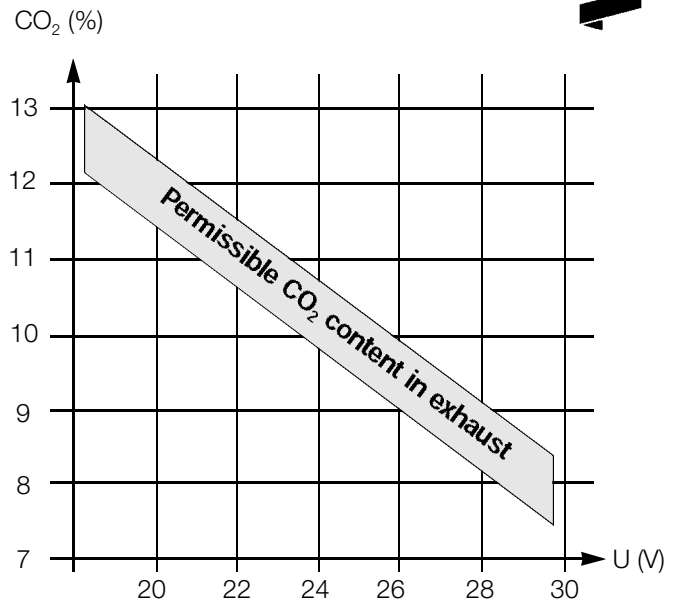

Adjusting the combustion gap

Adjusting fastening screws.

If the CO₂ content is below the figures in the graph reduce the combustion air gap by moving the air baffle plate.

If the CO₂ content is above the figures in the graph increase the combustion air gap by moving the air baffle plate.

- 1 Fastening screw
- 2 Air baffle plate
- 3 Combustion air gap

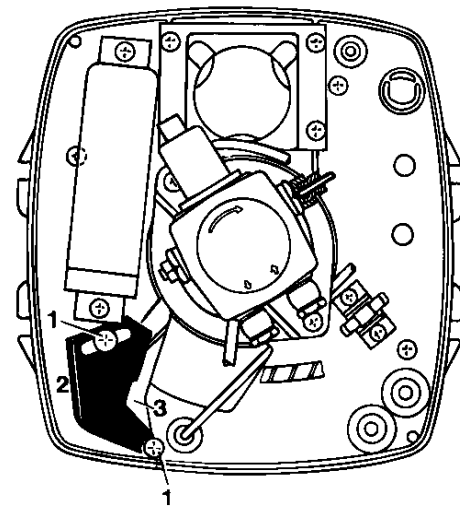

5. Dismantling water pump

- Remove screws from pump housing and remove intake flange
- Unscrew locking nut and remove impeller
- Remove axial face seal and thrust washer from monitor shaft
- Remove screws in pump flange and remove pump flange.
- Replace faulty parts.

Note: Clean axial face seal and thrust washer before assembly with a dry cloth. Contact faces must be free of grease and dust. Always replace O-ring.

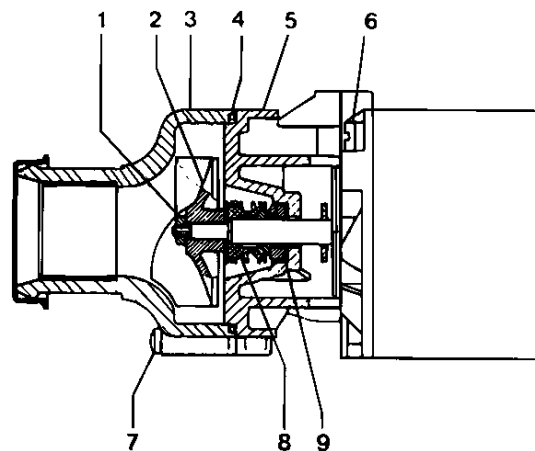

- | | | |
|---------------------|-----------------|---------------------|
| 1 Locking nut | 2 Impeller | 3 Pump housing |
| 4 O-ring | 5 Pump Flange | 6 Screw-pump flange |
| 7 Screw-pump casing | 8 Thrust washer | 9 Axial face seal |

6. Repairs

Removing the safety cap

Release both locking screws on the safety cap.
Remove safety cap

- 1 Locking screw

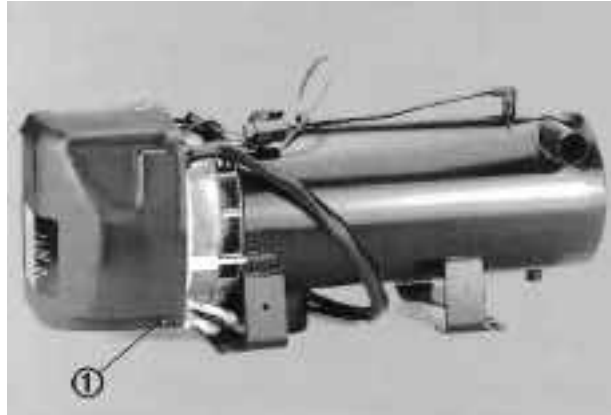

Removing the control unit

Remove safety cap.
Disconnect plugs from control unit.
remove control unit from holder.

Removing ignition spark generator

Remove safety cap
Disconnect both plug caps from ignition electrodes.
Disconnect electric plugs from control unit and unclip the black/red cable from the control unit casing.
Release locking screws from ignition spark generator.
Remove ignition spark generator and pull the two high voltage cables through the rubber grommets in the casing flange

- 1 Control unit
- 2 Holder for control unit
- 3 Ignition spark generator

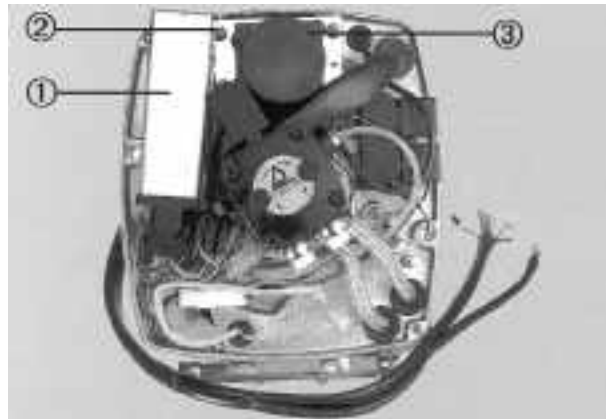

Removing burner

Remove safety cap.
Disconnect cable loom-safety thermal cutout fuse and cable loom-temperature probe.
Release two allen key bolts from burner.
Unscrew and remove burner from mounting.

Check gaskets for damages, replace if necessary .
Insert burner with holder into mounting.
Tighten both Allen key bolts alternatively.
Connect cable loom-safety thermal cutout fuse and cable loom-temperature probe.
Replace safety cap.

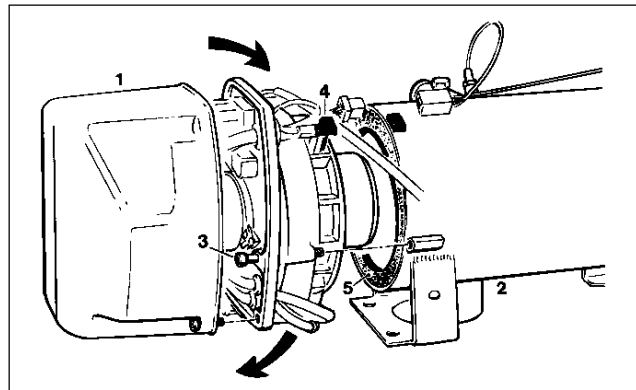

- | | |
|------------------|----------|
| 1 Burner | 4 Holder |
| 2 Heat Exchanger | 5 Gasket |
| 3 Locking screw | |



Removing fuel nozzle and ignition electrodes

Removing mixing head

Remove safety cap. Remove burner
Release both locking screws from mixing head and remove mixing head.

- 1 Mixing head



Removing ignition electrodes

Disconnect plug from ignition electrodes.
Loosen electrode holder and remove ignition electrodes.

Removing fuel nozzle

Unscrew fuel nozzle, collect the remaining fuel in a container

- 1 Ignition electrodes
- 2 Fuel nozzle
- 3 Fuel nozzle pre-heater

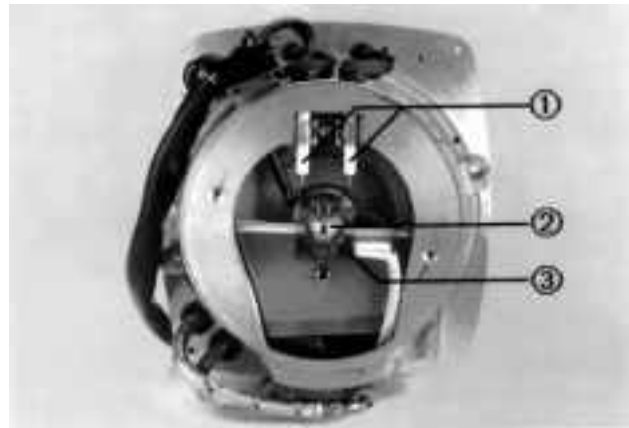

Adjusting the ignition electrode gap

The safety cap contains a setting gauge to adjust the ignition electrodes.
this is mounted on the nozzle holder with side A or B upwards, depending on the heater model.
In the case of fuel nozzles with an 80° spray angle the setting gauge must be mounted on the nozzle holder with side B upwards.

Release ignition electrode holder. Press setting gauge against the fuel nozzle and align the ignition electrodes so that the electrode tips rest against the two front corners of the setting gauge.

Place gasket and locking washer on electrodes and press against the casing with a pipe or spanner.
Connect ignition cable plug caps to electrodes.
Fasten mixing head.

Insert burner into holder and fasten in place.
Check CO₂ content in exhaust (Ref. pg.26).

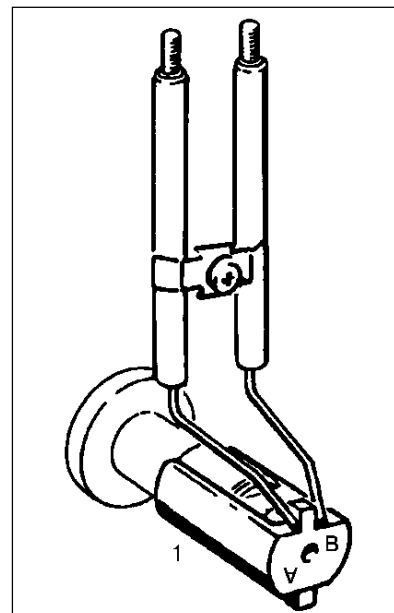

Removing the fuel pump

Remove safety cap. Remove control unit
 Mark the installation position of the fuel pump on the motor flange.
 Unscrew fuel lines from fuel pump.
 Disconnect solenoid valve cable from cable loom.
 Release the 3 Allen screws in the motor flange and remove fuel pump and coupling centre.
 Remove coupling half from fuel pump.

Replacing fuel pump

Mount coupling half on fuel pump.
 Insert coupling centre in the coupling half of the electric motor and insert fuel pump.
 Fasten fuel pump in motor flange with 3 Allen screws.
 Connect cable loom from solenoid valve.
 Connect fuel lines to fuel pump.
 Install control unit. Following installation check the fuel quantity and CO₂ content in exhaust. (Ref. pg.26)

- 1 Fuel pump
- 2 Allen screws
- 3 Fuel lines

Note: Note marking on the motor flange when fitting the fuel pump.

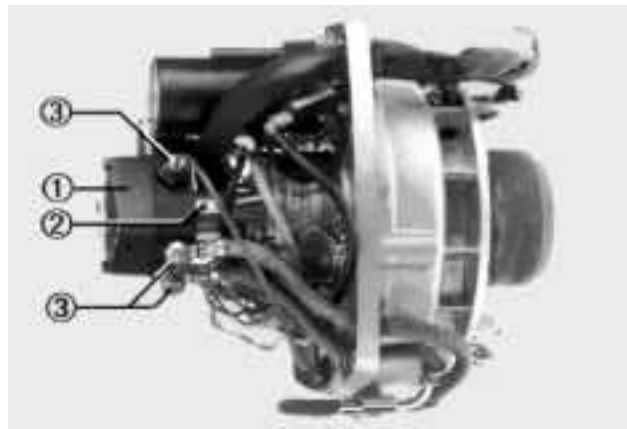

Removing the flame monitor

Release holder for flame monitor.
 Remove flame monitor from burner casing.
 Check optical part of the flame monitor: If the luminous intensity changes the resistance value has to be changed considerably.
 bright <30k Dark >100k
 If the values are not reached replace the flame monitor.
 Check cable for continuity.

When reinstalling the flame monitor the nose on the flame monitor must be inserted into the casing groove and the optical part pointing towards the burner chamber.

- 1 Flame monitor





Removing the electric motor

Remove safety cap. Remove flame monitor.
 Disconnect plug caps from ignition electrodes.
 Remove control unit.
 Remove fuel pump (loosen Allen screws on periphery and lay fuel pump carefully on one side).
 Unclip electric motor's black cable from control unit's plug, disconnect the brown cable from the electric motor at ground.
 Unscrew 4 locking screws from flange and remove flange from casing.
 Release fixing screws from impeller (tool: 2.5 Allen key, 1=115mm) and remove impeller from motor shaft.

Unscrew 3 fixing screws from electric motor and remove electric motor from flange. Remove coupling half-section from electric motor.

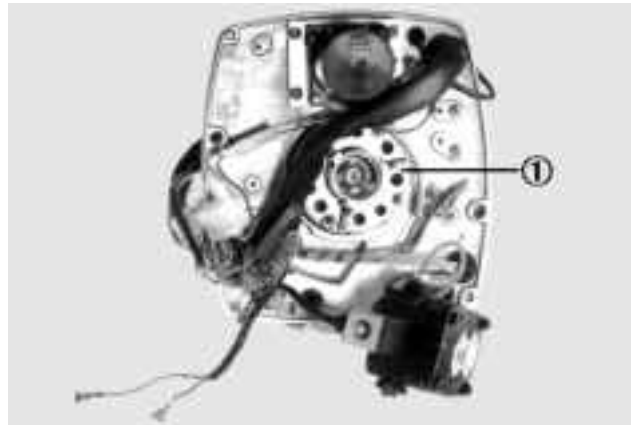

1 Electric motor



1 Locking screws

Mounting impeller

Adjusting the axial play

Mount impeller on motor shaft.
 Measure an axial gap of 0.4 mm (0.016") with a feeler gauge or a paper strip of corresponding thickness - as shown in corresponding diagram - adjust if necessary by moving the impeller.
 Tighten the impeller's fixing screw and check for free running.



Adjusting the radial play

Fasten the casing flange to the casing so that both parts can be moved in relation to one another. Measure a radial gap of 0.4mm (0.016") between the impeller and casing with a feeler gauge through the combustion air opening on the underside of the casing.

Adjust if necessary by moving the casing flange against the casing.

Tighten fastening screws and check impeller for free running.

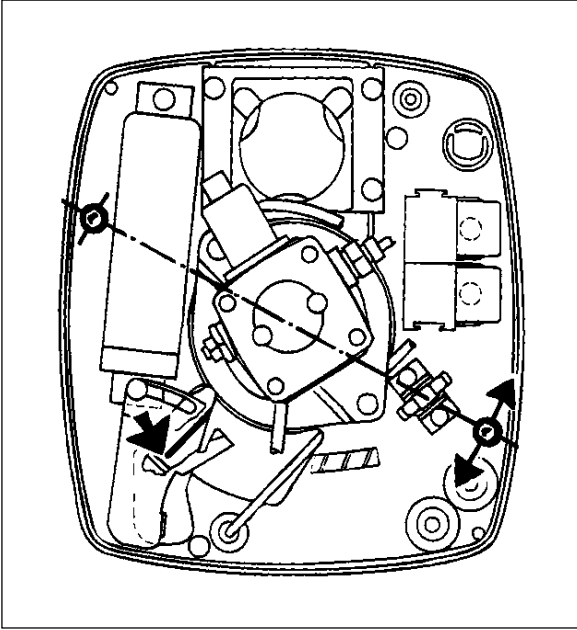

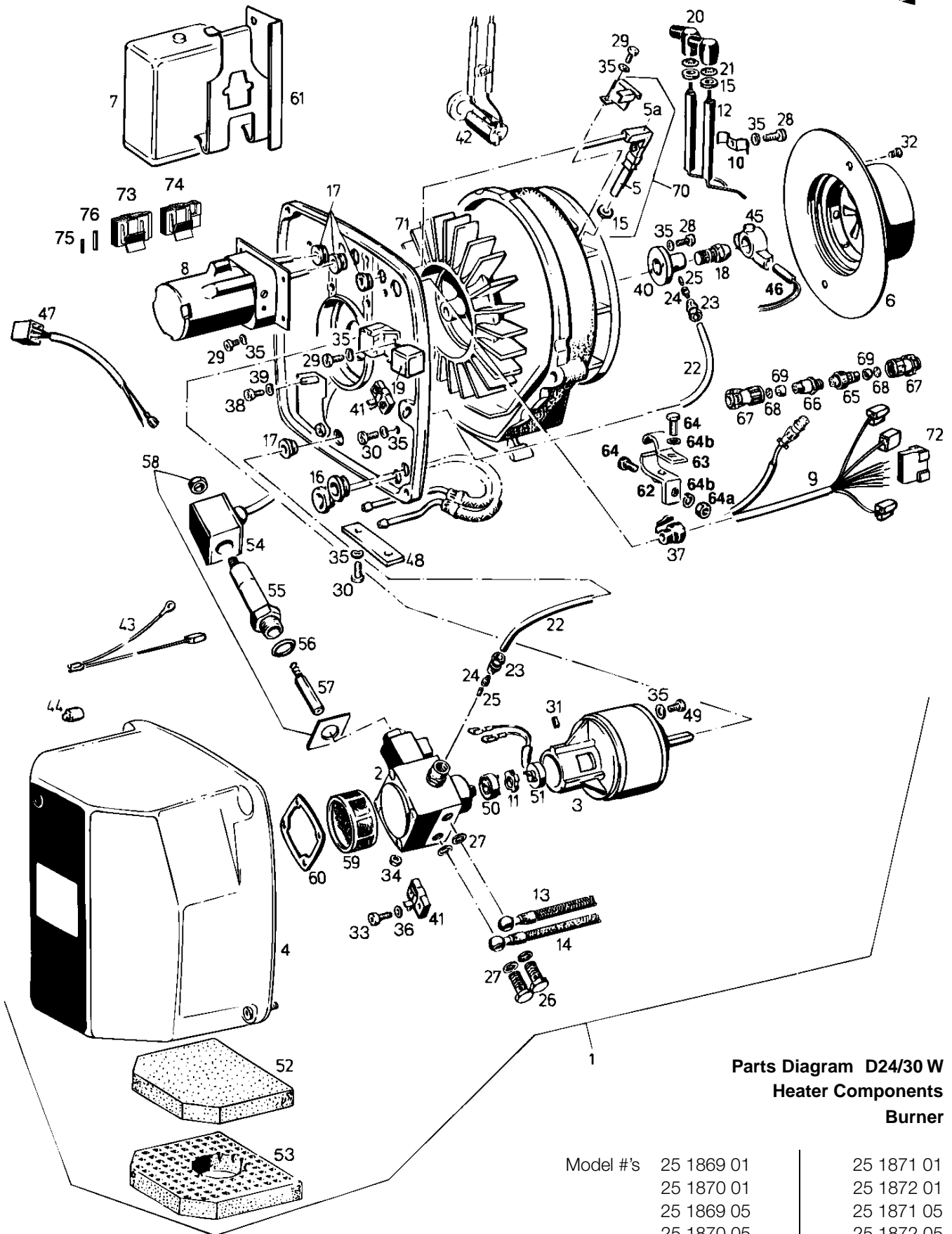

**Parts Diagram D24/30 W
Heater Components
Burner**

Model #'s	25 1869 01	25 1871 01
	25 1870 01	25 1872 01
	25 1869 05	25 1871 05
	25 1870 05	25 1872 05

Description & Part #'s			Model #		
Ref. No.	Description	Part Number	D 30 W	D 24 W	
			25 1871	25 1869	25 1870
1	Burner	D 24 W	25 1869 15 00 00	•	
			25 1870 15 00 00		•
		D 30 W	25 1871 15 00 00	•	
			25 1872 15 00 00		•
2	Fuel pump	25 1869 99 46 00	•	•	
3	Electric motor	25 1869 99 15 03	•	•	
4	Protective cover assembly	25 1779 15 06 00	•	•	
5	Photoresistive cell	25 1855 15 11 00	•	•	
5a	Cable	25 1855 15 08 00	•	•	
6	Mixing head assembly complete	25 1604 15 01 00	•	•	
7	Control unit	25 1733 50 00 14	•		
		25 1733 50 00 15		•	
8	Ignition spark generator	25 1869 99 56 00	•	•	
9	Cable tree	25 1869 15 02 00	•	•	
10	Holder	25 1371 15 00 04	•	•	
11	Coupling center part	25 1371 15 00 09	•	•	
12	Ignition electrode	25 1595 15 00 05	•	•	
13	Fuel return line	25 1706 15 00 11	•	•	
14	Fuel supply line	25 1595 15 00 10	•	•	
15	Sealing ring	25 1371 15 00 12	•	•	
16	Sleeve	25 1371 15 00 14	•	•	
17	Sleeve	25 1371 15 00 15	•	•	
18	Fuel atomizer nozzle	D 24 W	330 00 033	•	•
		D 30 W	330 00 029	•	•
19	Relay	203 00 066		•	
20	Ignition line plug connector	206 00 150	•	•	
21	Lockwasher	171 22 140	•	•	
22	Pipe	090 31 117	•	•	
23	Nipple	263 10 010	•	•	
24	Clamping ring	263 35 030	•	•	
25	Supporting sleeve	132 35 014	•	•	
26	Hollow screw	104 10 020	•	•	
27	Copper washers	323 16 014	•	•	
28	Allen head-screw	CA3 00 130	•	•	
29	Fillister head bolt	103 10 318	•	•	
30	Fillister head bolt	103 10 310	•	•	
31	Grub screw M5x8 DIN	Hardware	•	•	
32	Counter sunk screw M5x8 DIN	Hardware	•	•	
33	Fillister head bolt M4x16 DIN	Hardware	•	•	
34	Hexagon nut M6DIN	CA3 00 209	•	•	
35	Spring washer 5mm	CA3 00 306	•	•	
36	Spring washer 4mm	CA3 00 313	•	•	



Ref. No.	Description	Part Number	Model #		
			D 30 W	D 24 W	
			25 1871	25 1869	25 1870
37	Grommet	320 31 061	•	•	•
38	Fillisterhead bolt M4x6 DIN	Hardware	•	•	•
39	Disc	120 35 084	•	•	•
40	Nozzle holder	25 1436 15 00 03	•	•	•
41	Plug socket connection	25 1578 15 00 08	•	•	•
42	Setting gauge	25 1578 15 00 10	•	•	•
43	Cable	25 1752 15 03 00	•	•	•
44	LED indicator	201 00 056	•	•	•
45	Clamping piece	25 1371 89 16 00	•	•	•
46	Heat element	25 1371 89 15 02	•	•	•
47	Cable	25 1855 89 03 00	•	•	•
48	Shackle	25 1595 15 00 13	•	•	•
49	Fillister head bolt M5x10 DIN	Hardware	•	•	•
50	Coupling half	25 1371 15 01 01	•	•	•
51	Coupling half	25 1623 15 02 01	•	•	•
52	Upper damping plate	25 1371 15 06 03	•	•	•
53	Lower damping plate	25 1371 15 06 04	•	•	•
54	Solenoid coil	249 00 004	•	•	•
55	Armature	249 00 001	•	•	•
56	O-ring	249 00 003	•	•	•
57	Core	249 00 002	•	•	•
58	Hardware for solenoid	249 00 007	•	•	•
59	Filter	249 00 006	•	•	•
60	Cover seal	249 00 005	•	•	•
61	Holder	25 1779 15 05 00	•	•	•
62	Holder (lower)	25 1706 01 01 00	•	•	•
63	Holder (upper)	25 1706 01 00 03	•	•	•
64	Fillister head bolt M4x8 DIN	Hardware	•	•	•
64a	Hexagon nut M4 DIN	CA3 00 210	•	•	•
64b	Spring washer	CA3 00 306	•	•	•
65	Bush housing	206 31 344	•	•	•
66	Pin housing	206 31 343	•	•	•
67	Cable clamping element	209 00 001	•	•	•
68	Pressure plate	209 31 001	•	•	•
69	Seal	209 75 001	•	•	•
70	Flame sensor	25 1855 99 15 09	•	•	•
71	Combustion air blower wheel	25 1623 15 01 00	•	•	•
72	Flat plug housing	206 31 006	•	•	•
73	Socket housing	206 31 314	•	•	•
74	Socket housing	206 31 315	•	•	•
75	Flat plug	206 00 201	•	•	•
76	Twin leaf-spring contact	206 00 200	•	•	•

**Parts Diagram D24/30 W
Heat Exchanger**

Models 25 1869- 25 1870

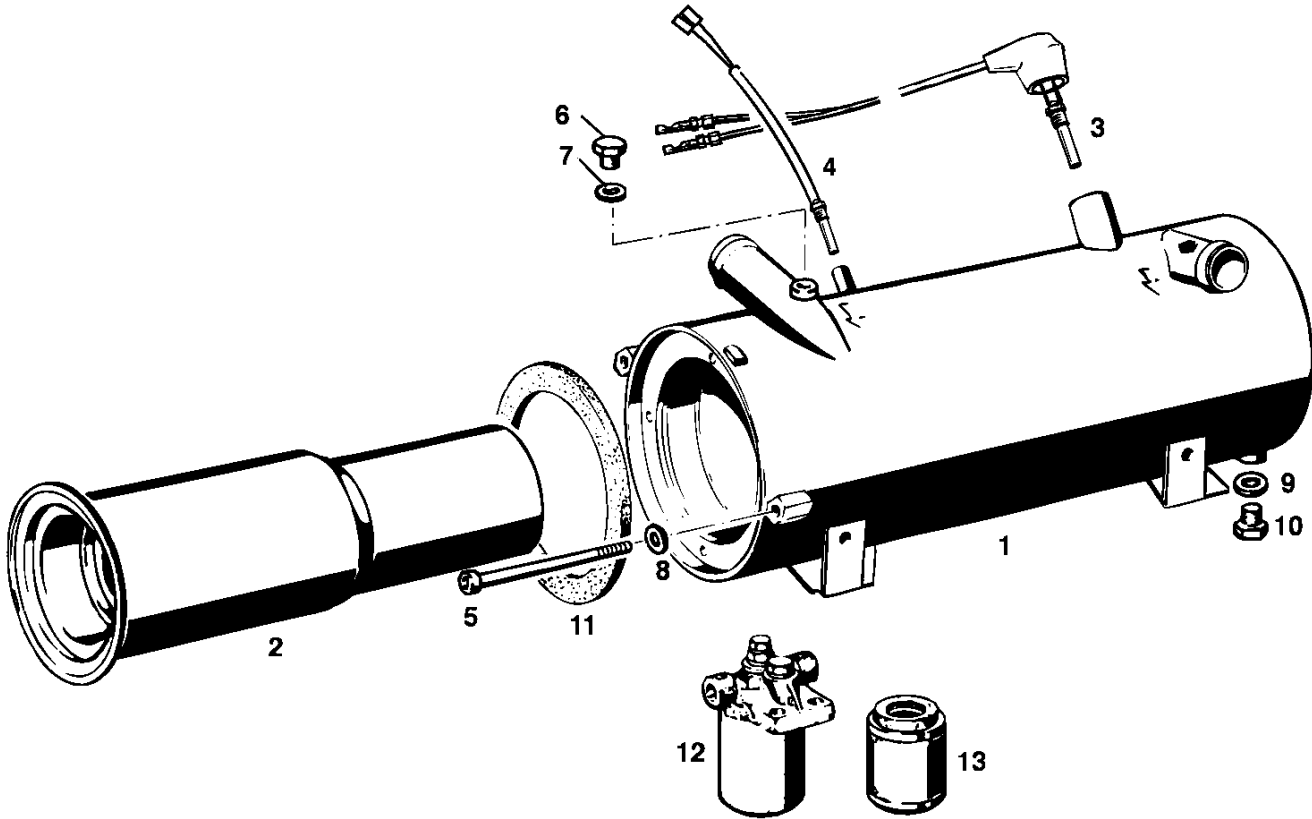

Ref. No.	Description	Part Number	Model #		
			D 30 W	D 24 W	
1	Heat exchanger	25 1855 06 00 00			
2	Flame tube	D 24 W			
		D 30 W			
3	Safety thermal cutout fuse	25 1706 40 07 00			
4	Temperature sensor	25 1706 01 08 00			
5	Allen hd. cap-M8x120 DIN	100 10 012			
6	Locking screw	105 20 000			
7	Sealing ring	324 97 043			
8	Disc	120 10 083			
9	Sealing ring	323 16 007			
10	Drain Plug	105 10 015			
11	Gasket	25 1371 01 00 02			
12	Fuel filter	330 00 052			
13	Fuel screen	CA0 12 064			



Parts Diagram D24/30 W
Water pumps
Models 25 1869- 25 1870

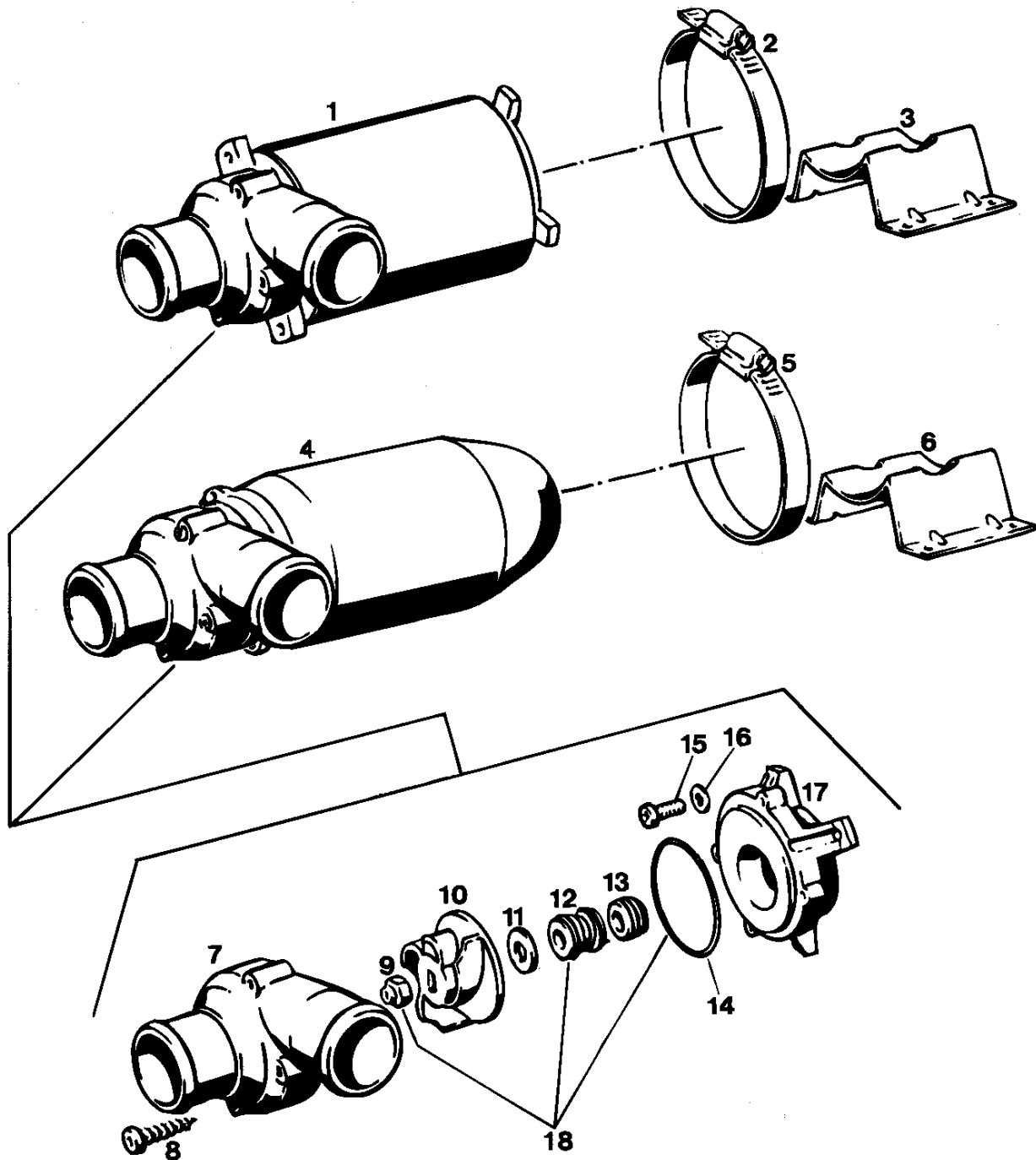

Description and Part #'s on next page.

Ref. No.	Description	Part Number	Model #		
			D 30 W	D 24 W	
1	Water pump (5000 l/hr)	25 1578 25 00 00			
2	Clamp clip	10 2065 07 00 90			
3	Pump holder	25 1371 25 00 01			
4	Water pump (6000 l/hr)	25 1371 89 37 00			
5	Clamp	10 2065 09 01 10			
6	Pump holder	25 1371 26 00 01			
7	Water pump case	25 1578 25 03 00			
8	Self tapping screw	108 10 332			
9	Locknut	114 10 055			
10	Impeller wheel	25 1436 25 01 01			
11	Disc	25 1578 25 01 05			
12	Axial face seal	329 00 092			
13	Ring-complete	329 00 080			
14	O-ring	320 31 098			
15	Screw tapite	109 00 044			
16	Spring washer	CA3 00 306			
17	Pump flange	25 1578 25 01 01			
18	Sealing components	25 1578 99 26 00			
	Sealing components @ ring 329 00 080	25 1578 99 26 00-001			



Parts Diagram D24/30 W

Compact version

Models 25 1869 05 00 00

25 1870 05 00 00

25 1871 05 00 00

25 1872 05 00 00

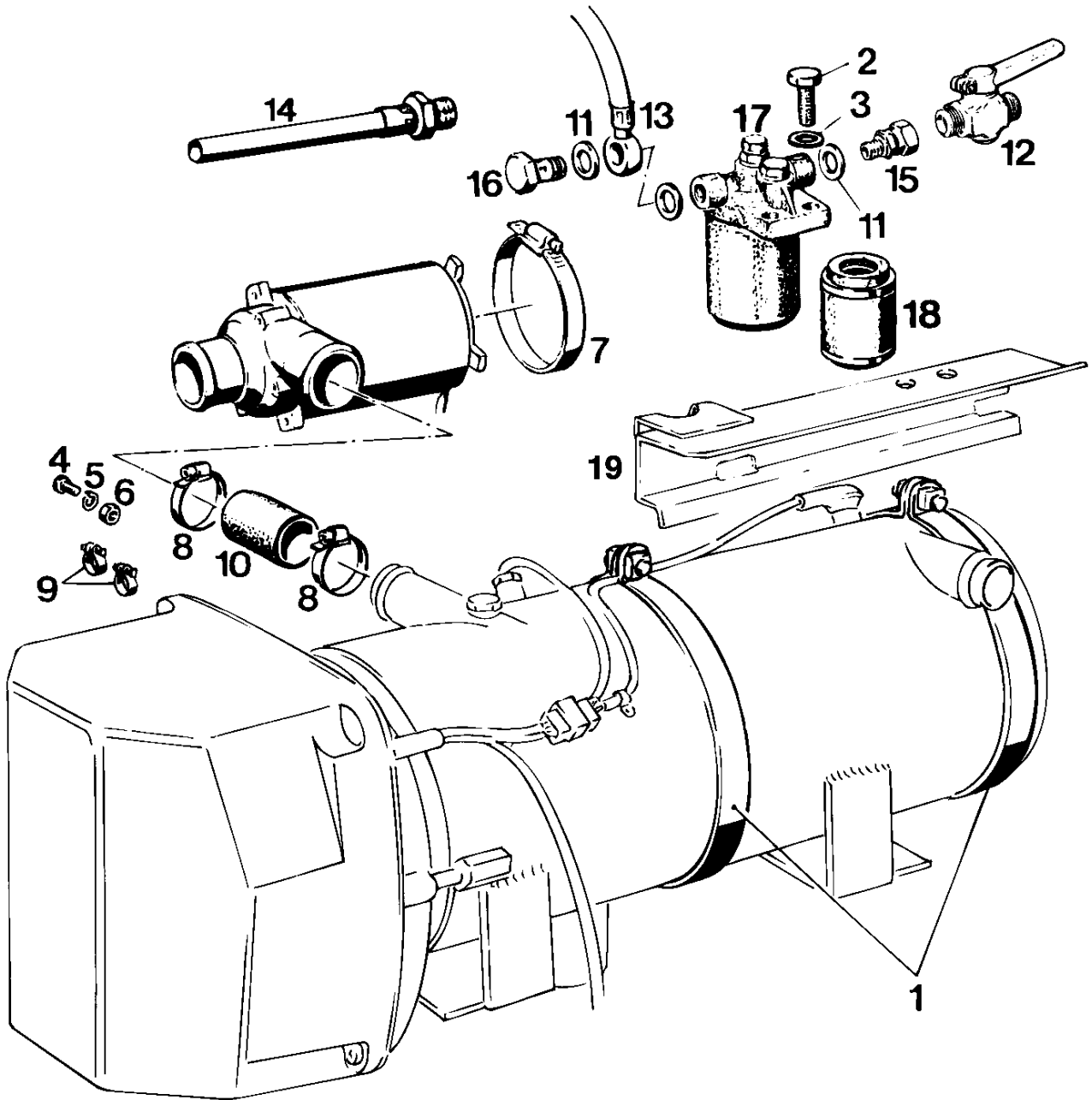

Description and Part #'s on next page.

Ref. No.	Description	Part Number	Model #		
			D 30 W	D 24 W	D 25 W
1	Clamping ring	10 2062 19 42 09		•	•
2	Hexagon bolt	100 10 071		•	•
3	Spring washer	Hardware		•	•
4	Fillister head bolt	Hardware		•	•
5	Spring washer	Hardware		•	•
6	Hexagon nut	Hardware		•	•
7	Hose clamp	10 2064 07 00 90		•	•
8	Hose clamp	10 2064 03 20 50		•	•
9	Hose clamp	10 2063 01 10 98		•	•
10	Hose	CA0 11 039-001		•	•
11	Washer	323 16 006		•	•
12	Rapid-closing valve	330 00 019		•	•
13	Fuel supply line	25 1698 05 03 00		•	•
14	Fuel return line	25 1698 05 04 00		•	•
15	Screw union	25 1706 05 01 00		•	•
16	Hollow screw	104 10 040		•	•
17	Fuel filter	330 00 052		•	•
18	Fuel screen	CA0 12 064		•	•
19	Bracket	25 1698 05 01 00		•	•

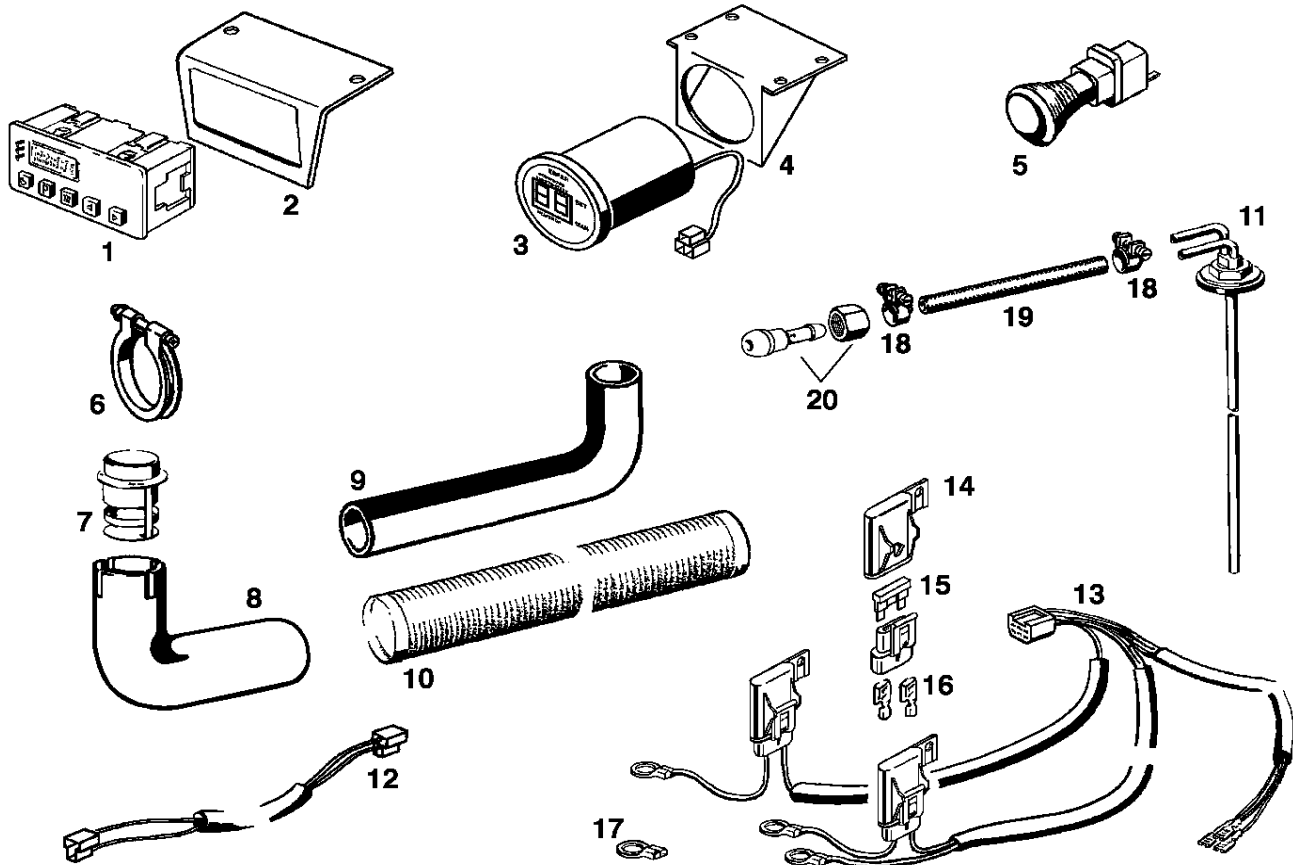

1st. Printing - March 1997

Printed in Canada

P/N: 610-109-10/96

Espar Products, Inc.

6435 Kestrel Road
Mississauga, Ontario
Canada L5T 1Z8

17370 N. Laurel Park Drive
Suite 400E
Livonia, Michigan
United States
48152

Canada (Tel): 905-670-0960
800-668-5676

Fax: 905-670-0728

U.S. (Tel): 800-387-4800

Member of **Eberspächer** Group of Companies