

COVIND

unlimited quality

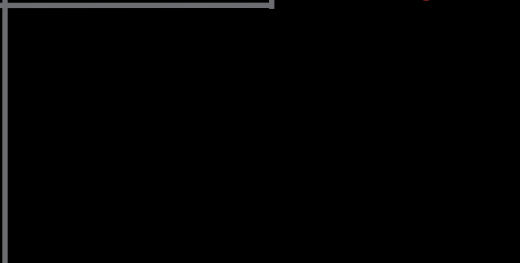

COVIND COV
 IND COVIND
 COVIND COV
 IND COVIND
 COVIND COV
 IND COVIND
 COVIND COV



SUITABLE TO
SCANIA
 2017

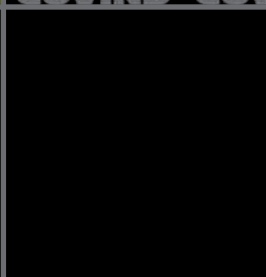



S U I T A B L E T O

SCANIA

MAGGIO
MAY
MAI

2017



BUREAU
VERITAS

SGS





كافت التفاصيل المذكوره هنا، وبالرغم من قابليتها للتبديل مع التفاصيل الاصليه بشكل متطابق تماما، إلا انها ليست
أصلية، نفس التفاصيل يتم الاستعانه بها واستخدامها فقط للعربات السائره فقط بعد الحصول على التصريح بالموافقه
من مالك العربيه التي يتم إصلاحها.
الأرقام الإرشاديه الأصلية يتم وضعها بغرض الاستعلام، نرجو أن يتم دائما ذكر أرقامنا الخاصة الإرشاديه في
التعاقدات وطلبات الشراء.
هذا الكاتالوج يلغي كافة الكاتالوجات السابقه ويحل محلها.



Всички особености изредени по-долу, независимо от това, че са взаимозаменяеми с оригиналите, **не са оригинали**. Те биват използвани само за превозните средства в движение и само след упълномощаване от страна на собственика на превозното средство в ремонт.



Selv om de sagtens kan bruges i stedet for de originale er de reservedele der indgår i **denne liste ikke originale**. Disse reservedele bruges kun til aktive køretøjer og udelukkende med ejerens tilladelse, mens reparationen udføres. De originale referencekoder fremstår kun som en oplysning. De bedes angive vores referencekoder i.f.m. forhandlinger og bestillingssedler. Det nye katalog annullerer og erstatter alle tidligere udgaver.



Selles nimekirjas olevad varuosad ei ole originaalid vaatamata sellele, **et on originaalidega võrdväärsealt kasutatavad**. Neid osasid kasutada ainult töös olevatel sõidukitel ja üksnes remonditava sõiduki omaniku loal. Originaali viitenumbrid on ära toodud ainult infoks. Palume müügi- ja tellimislehtedel ära märkida meie viitenumbrid. Käesoleva kataloogi nimekiri tühistab ja asendab varasemad.



Tässä luetteloidut varaosat eivät ole alkuperäisosa, vaikka **ne ovatkin laadultaan alkuperäisosa vastaavia**. Osat on tarkoitettu käytettäväksi liikenteessä olevissa autoissa ja niitä käytetään vain korjattavan ajoneuvon omistajan luvalla. Alkuperäiset tuotekoodit mainitaan vain tiedon vuoksi. Pyydämme teitä käyttämään neuvotteluissa ja tilauslomakkeissa meidän tuotekoodejamme. Uusi tuoteluettelo peruuttaa ja korvaa aikaisemmat luettelot.



Toutes les pièces détaillées ci-dessus, tout en étant parfaitement interchangeable avec les pièces d'origine, **ne sont pas originales**. Les mêmes pièces sont utilisées exclusivement sur les véhicules en circulation et seulement sous autorisation du propriétaire du véhicule en réparation. Les codes de référence originales sont indiqués à titre purement documentaire. Dans les négociations et les commandes veuillez bien citer nos codes de référence. Le présent catalogue annule et remplace tous les précédents.



Alle hier aufgeführten Bestandteile sind exakt austauschbar mit den Originalteilen, **aber es sind keine Originale**. Diese Teile werden nur angewendet und eingesetzt für die Fahrzeuge die im Umlauf sind und nur nach Einverständnis mit dem Eigentümer, dessen Fahrzeug in der Reparatur ist. Die Original-Referenznummern wurden rein informativ nochmals wiedergegeben. Bei Anfragen und bei Bestellungen bitten wir Sie immer die Referenznummern anzugeben. Der beigelegte Katalog ersetzt und annulliert die vorhergehenden Kataloge.



Κάθε ανταλλακτικό που απαριθμείται εδώ, ακόμα κι αν όντας τέλεια ανταλλάξιμο με το γνήσιο, **δεν είναι γνήσιο**. Αυτά τα μέρη χρησιμοποιούνται μόνο στα οχήματα που είναι σε κυκλοφορία και αποκλειστικά μετά από την έγκριση του ιδιοκτήτη του οχήματος για επισκευή. Οι γνήσιοι κωδικοί που αναφέρονται υπάρχουν για πληροφοριακούς λόγους μόνο. Παρακαλούμε όπως χρησιμοποιείτε για οποιαδήποτε συναλλαγή/ παραγγελία σας τους δικούς μας αναφερόμενους κωδικούς. Ο παρών κατάλογος ακυρώνει και αντικαθιστά προηγούμενους.



Spare parts listed here, even though perfectly interchangeable with the original ones, **are not original**. These parts are used only on vehicles in circulation and exclusively under authorization of the owner of the vehicle in repair. The original reference codes are indicated for information only. You are kindly requested to indicate our reference codes in negotiations and order sheets. The present catalogue list cancels and replaces previous ones.



قطعات قید شده در اینجا، با اینکه کاملاً قابل تعویض با قطعات اصلی می باشند، قطعات اصلی نیستند. این قطعات تنها برای خودروهایی که در جریان می باشند (خارج از محل تولید می باشند) مورد استفاده قرار می گیرند و منحصراً تحت اختیار و نضر مالک خودروی در حال تعمیر می باشند. با احترامات ما از شما شماره کد ارجاع اصلی تنها برای اطلاعات می باشند. تقاضا داریم که شماره کد ارجاع را در زمان مذاکره و در ورقه تقاضا مشخص کنید. لیست



Tutti i particolari qui elencati, pur essendo perfettamente intercambiabili con gli originali, **non sono originali**. Gli stessi vengono impiegati ed utilizzati solo per i veicoli in circolazione e solo dopo autorizzazione da parte del proprietario del veicolo in riparazione. I numeri di riferimento originali sono riportati a puro titolo informativo. Nelle trattative e nelle ordinazioni si prega di voler sempre citare i nostri numeri di riferimento. Il presente catalogo annulla e sostituisce tutti i precedenti.



Kaut arī uzskaitītās rezerves daļas var pilnīgi aizstāt oriģinālās, **tās nav oriģinālas**. Šīs rezerves daļas tiek izmantotas vienīgi apgrozībā esošiem transporta līdzekļiem un tikai ar remontējamā transporta līdzekļa īpašnieka atļauju. Oriģinālais atsauces numurs tiek uzrādīts vienīgi informācijai. Lūdzam norādīt jūsu atsauces numurus sarunu laikā un uz pasūtījuma lapas. Šis kataloga saraksts anulē un aizstāj visus iepriekšējos.



Čia išvardytos atsarginės dalys nėra originalios, tačiau jomis galima pakeisti originaliąsias. Šios dalys naudojamos tik apyvartoje esančiuose automobiliuose ir tik gavus remontuojamo automobilio savininko sutikimą.

Originalių dalių kodai nurodomi tik informacijos sumetimais. Maloniai prašome nusiskundimuose ir užsakymų lapuose nurodyti dalių kodus.

Šiame kataloge pateikiamas sąrašas anuliuoja ir pakeičia ankstesnius.



Reservedelene som er oppført her, er ikke **originale reservedeler**, selv om de fullt ut kan benyttes ved utskiftning av de opprinnelige delene. De skal kun benyttes på kjøretøy som er i bruk og med eierens samtykke. De opprinnelige referansekodene angis kun til etterretning. Vennligst angi våre referansekoder under forhandling og ved bestilling. Denne katalogen annullerer og erstatter alle tidligere kataloger.



Hoewel elk reserveonderdeel dat hier vermeld wordt perfekt kan worden gebruikt in de plaats van de originele stukken, **gaat het hier dus niet om originele onderdelen**. Deze onderdelen worden enkel gebruikt voor voertuigen in circulatie en enkel met de toestemming van de eigenaar van het voertuig dat in reparatie is. De originele referentiecodes worden enkel ter informatie weergegeven. U wordt vriendelijk verzocht om onze referentiecodes te gebruiken in gesprekken en op de bestelformulieren. De huidige catalogoog annuleert en vervangt de vorige versies.



Wszystkie detale tu podane ,choć będąc doskonałe wymienne z oryginałami, **nie są oryginalne**. Te same zostają zastosowane i użyte tylko dla pojazdów w obiegu i tylko po autoryzacji ze strony właściciela pojazdu będącego w naprawie.

Oryginalne numery referencyjne są umieszczone w celu czysto informacyjnym.

W czasie rozmów handlowych i zamówień, prosi się zechcieć zawsze cytować nasze numery referencyjne.

Niniejszy katalog anuluje i zastępuje wszystkie poprzednie.



Todas as peças aqui listadas, ainda que sejam perfeitamente intercambiáveis com as originais, **não são originais**. Estas peças só são empregues e utilizadas nos veículos em circulação e só após autorização prévia por parte do proprietário do veículo a reparar. Os números de referência originais têm um carácter puramente informativo. Nos contactos e encomendas, indique sempre os números de referência, por favor.



Veškeré zde uvedené součástky **nejsou originální díly**, i když jsou za ně stoprocentně zaměnitelné. Tyto součástky je možné použít pouze pro vozidla v provozu a pouze se souhlasem majitele vozidla, které má být opraveno. Referenční čísla originálních dílů jsou uvedena pouze informativně. Při jednáních a na objednávkách je nutné vždy uvést naše referenční čísla.

Tento katalog anuluje a nahrazuje veškeré předchozí katalogy.



Toate produsele enumerate in continuare, chiar daca sunt perfect interschimbabile cu cele originale, **nu sunt originale**. Ele sunt utilizate, numai pentru autovehiculele in circulatie si exclusiv cu acordul proprietarului autovehiculului de reparat. Codurile originale sunt indicate numai in scop informativ. Cu ocazia tratativelor verbale, cat si a emiterii ordinelor scrise, clientii sunt rugati sa utilizeze codurile noastre (COVIND) ca referinta. Prezentul catalog anuleaza si le inlocuieste pe cele precedente.



Все перечисленные запчасти не являются оригинальными, **хотя могут отлично их заменить**. Эти запчасти используются при ремонте автомобилей только с согласия владельца.
Ссылки на порядковый номер оригинальных запчастей указаны исключительно в ориентировочных целях.

При покупках и заказах рекомендуем указывать НАШИ номера запчастей.

Настоящий каталог анулирует и заменяет все предыдущие.

Оригинальные ориентировочные номера са изнесени само за ваша информация. При преговори и при поръчки молим винаги да цитирате нашите ориентировочни номера.

Настоящият каталог анулира и замества всички съществуващи до момента.



Ovdje popisani prièuvni dijelovi, èak i kada savršeno zamjenjuju izvorne, **nisu izvorni**. Ti dijelovi mogu se uporabiti jedino na vozilima u cirkulaciji i na temelju izrièitoga odobrenja vlasnika vozila na popravku. Brojevi dijela izvornih dijelova navedeni su samo kao primjer. Najljepše vas molimo da u vašim zahtjevima i narudžbama navedete brojeve dijela.

Sadašnji katalog ukida valjanost svih prethodnih kataloga.



Èeprav jih je možno perfektno izmenjati z originalnimi deli, tukaj navedeni nadomestni deli niso originalni. Te dele se uporabljajo samo v vozilih v prometu in izkljuèno samo pod pogojem, da lastnika vozila v popravilu izda zato dovoljenje. Navedene originalne referenène kode so le informativne. Prosimo vas, da navedite naše referenène kode pri pogajanju in na naroèilih. S sedanjim seznamom prenehajo veljati prejšnji sezname in jih nadomesti.



Todos los elementos detallados a continuación, aunque totalmente intercambiables con los originales, **no son originales**. Estos mismos se emplean y utilizan unicamente para vehículos en circulación y previa autorización del propietario del vehículo en reparación. Los numeros de referencia originales se citan a título informativo. En las negociaciones y en los pedidos se ruega citar siempre nuestros numeros de referencia. El presente catálogo anula y substituye todos los anteriores.



Reservdelarna i denna lista är inte originaldelar trots att de **är fullkomligt utbytbara med de ursprungliga**. Dessa delar används endast på fordon i cirkulation och enbart efter godkännande av ägaren till det fordon som lämnats på reparation. De originala referenskoderna anges endast för information. Var god ange våra referenskoder i negocieringar och beställningsblanketter. Den nuvarande kataloglistan annullerar och ersätter de föregående.



Devamında detaylandırılan tüm elementler, orijinalleri ile tamamen değiştirilebilir olmasına rağmen, **orijinal değildirler**. Bunlar, yalnızca dolaşımda bulunan araçlarda ve tamirde bulunan aracın sahibinden ön onay alınması kaydıyla uygulanabilir ve kullanılabilir.

Orijinallerin referans numaraları bilgi başlığında yer almaktadır.

Görüşmelerde ve siparişlerde referans numaralarımızın her zaman belirtilmesi rica olunur.

Bu katalog tüm önceki versiyonları geçersiz kılar ve bunların yerine geçer.



Перелічені тут запасні частини не є оригінальними, але цілком взаємозамінні з оригінальними. Ці запасні частини застосовуються тільки на транспортних засобах, що знаходяться в експлуатації і винятково з дозволу власника, що здав транспортний засіб у ремонт.

Коди оригінальних запасних частин наводяться тільки для довідки. Прохання вказувати довідкові коди запасних частин при веденні переговорів і на бланках замовлення.

Даний каталог скасовує дію раніше виданих каталогів і замінює ці каталоги.



Az itt felsorolt tartalék alkatrészek, még akkor is, ha megfelelően felcserélhetők az eredetiekkel, nem az eredetiek. Ezeket az alkatrészeket csak forgalomban lévő járművek javításánál használják és kizárólag a jármű tulajdonosának engedélyével.

Az eredeti referencia kódokat csak információs célból jelzik. Kérjük legyen szíves jelezze a referencia kódjainkat a tárgyalásokon és a megrendelési dokumentumban.

A jelenlegi katalógus lista vissza van vonva és újra az előző lista van érvényben.

Si consiglia di consultare sempre il catalogo on-line per gli ultimi aggiornamenti.

Please visit the catalogue on line for the latest updates.

il est conseillé de toujours consulter le catalogue en ligne pour les dernières mises à jour.

Wir empfehlen Ihnen immer unsere on-line Kataloge nachzuschlagen, um die letzten Aktualisierungen zu kennen

Les recomendamos consulten siempre el catálogo en línea para las últimas actualizaciones.

<http://catalogo.covind.it>



Recomenda-se a consulta do catálogo eletrónico para informação das novas atualizações.

Zaleca się odwiedzać zawsze katalog on-line zawierający najnowsze aktualizacje

E consiliabila intotdeauna, consultarea catalogului on-line pentru cunoasterea ultimilor actualizari.

Пожалуйста, обратите внимание на последние обновления каталогов on-line

للأطلاع على آخر التحديثات.
الرجاء الرجوع دائما الي كاتالوجاتنا على الخط.

www.covind.it



Indice Index Verzeichnis

LEGENDA SPECCHI MIRROR KEY SPIEGEL-LEGENDE Intro 2

NORMATIVA REGULATION VORSCHRIFT Intro 3

TABELLE COMPARATIVE CROSS REFERENCES KORRESPONDENZTABELLE

OEMCOVIND Intro 5

COVINDOEM Intro 12

PESANTI TRUCKS NUTZFAHRZEUGE

[146]	Scania R2010	CP	1
[146]	Scania R2010	CG/CR	57
[SCP]	Scania R	CP	125
[SCR]	Scania R	CG/CR	179
[094]	Scania 94	CP	237
[144]	Scania 144	CR	277
[093]	Scania 93	CP	317
[143]	Scania 143	CR	323
[092]	Scania 92	CP	333
[142]	Scania 142	CR	339

Legenda

	Guida destra/sinistra Right and left-hand drive Rechts- und Linkslenkung		Lato sinistro Left side Links einsetzbar		Colore Silver Color Silver Farbe Silber
	Guida destra Right-hand drive Rechtslenkung		Braccio Polipropilene e Fibra di vetro PP+GF mirror arm Spiegelarm aus Polypropylen und Glasfaser		Colore Nero e Grigio Color Black/Grey Farbe Schwarz/Grau
	Guida sinistra Left-hand drive Linkslenkung		Braccio integrato Integrated arm Integrierten Arm		Raggio 1200 di convessità specchio principale Mirror glass bend radius: 1200 Wölbungsradius des Spiegelglases 1200
	Braccio corto - destro Short arm - right Kurzer Spiegelarm, rechts		Braccio in acciaio (ø 28 mm / ø 40 mm) Steel arm (ø 28 mm / ø 40mm) Spiegelarm aus Stahl (ø 28 mm / ø 40 mm)		Raggio 300 di convessità specchio ausiliario Mirror glass bend radius: 300 Wölbungsradius des Weitwinkelspiegelglases 300
	Braccio corto - sinistro Short arm - left Kurzer Spiegelarm, links		Braccio in alluminio (ø 28 mm / ø 40 mm) Aluminium arm (ø 28 mm / ø 40 mm) Spiegelarm aus Aluminium (ø 28 mm / ø 40 mm)		Curvo Convex Gewölbtes Glas
	Braccio medio - destro Middle arm - right Mittlerer Spiegelarm, rechts		Materiale: ABS Material: ABS Kunststoff ABS		Classe II: specchio principale Class II: main mirror Klasse II: Hauptspiegel
	Braccio medio - sinistro Middle arm - left Mittlerer Spiegelarm, links		Braccio completo di copribraccio inferiore Arm with lower cover kompletter Spiegelarm mit unteren Haltebock		Classe IV: specchio ausiliario Class IV: auxiliary mirror Klasse IV: Weitwinkelspiegel
	Braccio lungo - destro Long arm - right Langer Spiegelarm, rechts		Braccio completo di copribraccio superiore e inferiore Arm with upper and lower cover kompletter Spiegelarm mit oberen und unteren Haltebock		Classe III: specchio ausiliario Class III: auxiliary mirror Klasse III: Weitwinkelspiegel
	Braccio lungo-sinistro Long arm - left Langer Spiegelarm, links		Braccio completo di supporto superiore Arm with upper bracket kompletter Spiegelarm mit oberen Haltebock		Superiore Top Höher
	Lato destro/sinistro Right/left side Links/rechts einsetzbar		Colore Nero Color Black Farbe Schwarz		Centrale Central Zentral
	Lato destro Right side Rechts einsetzbar		Colore Grigio Color Grey Farbe Grau		Inferiore Bottom Unter



Doppio specchio
Double glass
Zweispiegel



Regolazione elettrica
Remote control
Elektrisch verstellbar



Regolazione manuale
Manual control
Manuell verstellbar



Specchio riscaldato 24V (sbrinamento)
Heated 24 V
Spiegel beheizt 24 V (Entfrostdung)



Specchio riscaldato (sbrinamento)
Heated
Spiegel beheizt (Entfrostdung)



Braccio con cavo per movimento elettrico
Arm with electric wire
Spiegelarm mit Steuerkabel



Braccio con cavo per riscaldamento 24 V
Arm with heat wire 24 V
Spiegelarm mit Heizkabel



Sistema di bloccaggio
Blocking System
Haltebock



Vetro specchio con supporto
Mirror glass unit
Glas mit Spiegelhalter



Ribaltamento elettrico
Electrically foldable
Elektrisch einklappbar



Lampeggiatore luce bianca (W)
White light blinker (W)
Blinker weisslicht (W)



Lampeggiatore luce arancione (W)
Orange light blinker (W)
Blinker orangeflicht (W)



Sonda
Sensor
Sensor



Antenna
Antenna
Antenne



Supporto con attacco circolare
Circular attack support
Unterstützung mit Rundangriff



Fornito smontato
Unassembled
Zerlegte Lieferung



Imballo
Packing
Verpackung



Selezionatore specchio destro/sinistro
Mirrors' selector right/left
Spiegelverstellung rechts/links



Azionamento alzacristalli
Windows' drive power
Antriebsseite Fensterheber



Retroilluminato
Courtesy lighted
Rueckbeleuchtet



* L'OEM fornisce R400-R1800, COVIND R300-R1200 come da normativa vigente. L'indicazione "*" nel codice OEM ha pertanto il solo scopo di aiutare il cliente nell'identificazione del prodotto Covind equivalente.

* OE supplies R1800-R400 while COVIND R1200-R300 according to the valid Regulation.

The symbol "*" near the OEM code is used only for comparison purposes helping the customer to properly identify the equivalent item.

* OEM beliefer R1800-R400 während COVIND liefern in R1200-R300 die Europa normative folgend.

Die Angabe "*" im Original-Referenz dient dazu, dem Kunden zu helfen, den Covind passenden Produkt zu ermitteln.

Normativa . Regulation . Vorschrift

Secondo le direttive:

CE 2003/97 valida dal 01/2007

CE 2007/38 valida da 04/2009

With reference to:

2003/97/EC Regulation valid from January 2007

2007/38/EC Regulation valid from April 2009

Gemäß EG-Verordnung:

2003/97/EC Gültig ab Januar 2007

2007/38/EC Gültig ab April 2009

A Sistema specchio completo (II+IV+Braccio)
Complete Mirror (Class II+IV+arm)
Komplettspiegel (Klasse II+IV+Arm)

B Unità specchio (II/IV)
Mirror unit (Class II/Class IV)
Spiegeleinheit (Klasse II/IV)

C Componenti di ricambio
Spare parts
Ersatzteile

Codice Covind
Covind code
Covind Nr.

Codici Originali
O.E.M. Ref.
OE Nummer

Posizione Specchio
Mirror position
Einsetzung des Spiegels

- Particolare presente in assortimento Covind;
Item in Covind Range
Teil in unserer Produktpalette
- Particolare non presente in assortimento Covind
Item not in Covind Range
Teil nicht in unserer Produktpalette

Numero di Omologazione
CE number
Homologations-Nr.

MAN		XXL/508		XXL/508		XXL/508	
A	XXL/508						
	II (E4)024100 176x379 mm				(E4)024100		328x935 mm
	IV (E4)024101 167x177 mm				(E4)024101		177x167 mm
	applicabilità: applicable to: Verwendbar für	MAN TGA LX 12/2006 → MAN TGM 12/2006 → 11/2014 MAN TGL 12/2006 → 11/2014					
B	XXL/522 II	81637306481					216x167 mm
	XXL/524 IV	81637306513					229x187 mm
C	a XXL/512	81637316618 (81637316614)					
	b XXL/500	81637336049					
	c XXL/501	81637336057					
	d XXL/506	81637320060 (81637320055) (81637320064)					215x398 mm
	e XXL/502	81637320062 (81637320056) (81637320066)					215x398 mm
	f -	-					

Dimensioni particolare (larghezza x altezza)
Item dimensions (Width x Height)
Abmessungen des Teiles (Länge * Höhe)

138 - adattabile a :: suitable to :: assend an MAN

OEMCOVIND

Tabelle Comparative :: Cross References :: Korrespondenztabelle

Cod. Originale O.E.M. Ref. OE Nummer	Cod. Covind Covind Ref. Covind Teilnummer	Pag.Cat. Page Cat. Seite
280378	092/160	334
281377	142/161	340
281378	142/160	340
296028	142/172	327,343
296206	142/166	327,343
296833	142/183	327,343
296834	142/182	327,343
303076	142/144	325,34
303080	092/145	334
316640	142/ 25	326,342
316756	142/ 94	341
316756	142/ 96	341
322928	142/100	319,324,335,341
336759	142/175	327,343
336760	142/174	327,343
336938	142/172	327,343
336979	142/165	327,343
336980	142/164	327,343
343107	092/231	322,338
343108	092/230	322,338
343109	143/231	328,346
343110	143/230	328,346
356084	142/196	326,342
356085	142/197	326,342
356086	142/196	326,342
356087	142/196	326,342
356490	142/800	325,34
356540	142/170	327,343
356942	142/ 9	327,343
361019	143/241	328
361020	143/240	328
361993	143/245	322,328,338
361994	143/244	322,328,338
370990	142/100	319,324,335,341

Cod. Originale O.E.M. Ref. OE Nummer	Cod. Covind Covind Ref. Covind Teilnummer	Pag.Cat. Page Cat. Seite
376116	142/166	327,343
376283	142/181	326,342
376284	142/180	326,342
381698	143/ 90	324
389048	092/145	334
524533	142/177	327,343
524783	142/165	327,343
524784	142/164	327,343
524795	142/175	327,343
524796	142/174	327,343
581025	144/196	16,80,137,193,245,285
1109951	142/ 7	326,342
1109952	142/ 6	326,342
1110301	143/ 90	324
1123519	092/145	334
1123520	093/145	318
1300831	142/100	319,324,335,341
1303318	143/ 90	324
1306492	144/ 50	240,282
1306975	142/197	326,342
1306975	142/198	326,342
1306976	142/196	326,342
1306976	142/198	326,342
1308475	143/442	324
1310203	144/247	264
1310204	144/248	264
1310213	144/249	264
1310214	144/246	264
1310589	144/217	261,301
1310590	144/216	261,301
1313594	143/520	329
1317537	092/145	334
1317538	093/145	318
1324596	144/ 90	278

Cod. Originale O.E.M. Ref. OE Nummer	Cod. Covind Covind Ref. Covind Teilnummer	Pag.Cat. Page Cat. Seite
1324597	144/ 95	279
1324598	144/ 94	279
1324599	144/155	242,284
1324600	144/154	242,284
1324605	144/203	36,102,155,214,262,302
1324606	144/202	36,102,155,214,262,302
1335391	144/200	36,102,155,214,262,302
1335392	144/204	37,103,156,215,263,303
1336013	094/ 90	238
1338365	092/231	322,338
1338366	092/230	322,338
1338377	143/231	328,346
1338378	143/230	328,346
1346163	144/ 15	83,139,195,247,287
1346164	144/ 14	83,139,195,247,287
1346177	144/193	246
1346178	144/192	246
1346380	144/512	21,23,25,27,29,31,85, 87,89,91,93,95,141,143, 145,147,149,151,197,199, 201,203,205,207,249,251, 253,255,257,259,289,291, 293,295,297,299
1346937	144/ 11	17,81,138,194,286
1346938	144/ 10	17,81,138,194,286
1346939	144/ 13	17,81,138,194,286
1346940	144/ 12	17,81,138,194,286
1351193	144/231	260,3
1351194	144/230	260,3
1351203	144/215	261,301
1354593	144/239	261,301
1354594	144/238	261,301
1357599	144/519	38,39,40,41,104,105,106, 107,158,159,160,161,216,

OEMCOVIND

Tabella Comparative :: Cross References :: Korrespondenztabelle

Cod. Originale O.E.M. Ref. OE Nummer	Cod. Covind Covind Ref. Covind Teilnummer	Pag.Cat. Page Cat. Seite
1357599	144/519	217,218,219,266,267, 268,269,306,307,308,309
1357600	144/518	38,39,40,41,104,105,106, 107,158,159,160,161,216, 217,218,219,266,267,268, 269,306,307,308,309
1357601	144/520	38,39,104,105,158,159, 216,217,266,267,306,307,332
1357602	144/530	40,41,106,107,160,161, 218,219,268,269,308,309
1358315	SCR/535	52,53,120,121,174,175, 232,233,272,273,312,313
1358316	SCR/534	52,53,120,121,174,175, 232,233,272,273,312,313
1358317	SCR/537	44,45,110,111, 164,165,222,223
1358318	SCR/536	44,45,110,111, 164,165,222,223
1358831	144/104	238,279
1358832	144/103	238,279
1362707	SCR/505	34,99,153,211
1362708	SCR/523	106,160,218,268,308
1362711	144/220	37,103,156,215,263,303
1364665	144/207	37,103,156,215,263,303
1364666	144/206	37,103,156,215,263,303
1366243	144/140	241,282
1366287	094/137	240
1366288	094/136	240
1366384	144/150	241,283
1366735	144/114	17,81,138,194,286
1366781	144/115	17,81,138,194,286
1366832	144/140	241,282
1366849	144/175	18,83,195,246,287
1366850	144/174	18,83,195,246,287

Cod. Originale O.E.M. Ref. OE Nummer	Cod. Covind Covind Ref. Covind Teilnummer	Pag.Cat. Page Cat. Seite
1366851	144/800	243,283
1368652	SCR/522	106,160,218,268,308
1370107	094/163	244
1370108	094/162	244
1370329	144/161	280,281
1370330	144/160	280,281
1371754	094/147	239
1371757	144/147	281
1371758	144/148	281
1371856	144/145	282
1371857	094/145	239
1375457	094/ 95	238
1375458	094/ 94	238
1376832	094/ 90	238
1379997	144/106	243,283
1381479	144/135	241,283
1381480	144/134	241,283
1381563	144/159	244,28
1381564	144/158	244,28
1381565	144/165	280,281
1381566	144/164	280,281
1382727	144/163	280,281
1382728	144/162	280,281
1383520	144/516	38,40,104,106,158,160, 216,218,266,268,306,308
1383609	144/110	282
1383858	144/515	38,40,104,106,158,160, 216,218,266,268,306,308
1383887	094/137	240
1383888	094/136	240
1386957	094/161	244
1386958	094/160	244
1386959	094/165	244
1386960	094/164	244

Cod. Originale O.E.M. Ref. OE Nummer	Cod. Covind Covind Ref. Covind Teilnummer	Pag.Cat. Page Cat. Seite
1387870	144/500	212,265,304
1390074	144/236	260,3
1390075	144/237	260,3
1390076	144/212	261,301
1391144	SCR/235	100,211
1393447	094/136	240
1395097	SCR/537	44,45,110,111, 164,165,222,223
1395098	SCR/536	44,45,110,111, 164,165,222,223
1395099	SCR/537	44,45,110,111, 164,165,222,223
1395100	SCR/536	44,45,110,111, 164,165,222,223
1395276	144/525	38,39,104,105,158,159, 216,217,266,267,306,307
1395871	144/100	278
1397570	144/145	282
1397571	094/145	239
1398873	144/210	36,102,155,214,262,302
1400207	144/104	238,279
1400208	144/103	238,279
1400213	144/ 90	278
1400899	SCR/529	50,51,116,117,170,171, 228,229,270,271,310,311
1400900	SCR/528	50,51,116,117,170,171, 228,229,270,271,310,311
1401929	144/146	281
1401931	094/146	239
1406223	144/181	246
1406224	144/180	246
1408465	144/200	36,102,155,214,262,302
1408466	144/204	37,103,156,215,263,303
1422292	144/ 7	18,82,139,195,247,287

OEMCOVIND

Tabelle Comparative :: Cross References :: Korrespondenztabelle

Cod. Originale O.E.M. Ref. OE Nummer	Cod. Covind Covind Ref. Covind Teilnummer	Pag.Cat. Page Cat. Seite
1422843	SCR/100	127,181
1422991	144/104	238,279
1422992	144/103	238,279
1423017	144/195	16,80,137,193,245,285
1423018	144/194	16,80,137,193,245,285
1426925	144/ 6	18,82,139,195,247,287
1426927	144/ 9	18,82,139,195,247,287
1429393	144/203	36,102,155,214,262,302
1429394	144/202	36,102,155,214,262,302
1431256	144/101	9,67,136,192,242,284
1431257	144/102	9,67,136,192,242,284
1431584	SCR/233	5,58,127,181
1431585	SCR/232	5,58,127,181
1431920	SCR/155	9,67,136,192
1431921	SCR/154	9,67,136,192
1431922	SCR/157	67,192
1431923	SCR/156	67,192
1431925	SCR/ 95	131,185
1431926	SCR/ 94	131,185
1431931	SCR/203	102,214
1431932	SCR/202	102,214
1431933	SCR/207	103,215
1431934	SCR/206	103,215
1435542	SCR/ 50	72,188
1438557	SCR/159	136,192
1438558	SCR/158	136,192
1438563	SCP/159	9,67,136,192
1438564	SCP/158	9,67,136,192
1439788	SCR/ 93	129,183
1439789	SCR/ 92	129,183
1440108	144/159	244,28
1440113	144/158	244,28
1442294	144/175	18,83,195,246,287
1442295	144/174	18,83,195,246,287

Cod. Originale O.E.M. Ref. OE Nummer	Cod. Covind Covind Ref. Covind Teilnummer	Pag.Cat. Page Cat. Seite
1442653	SCR/237	97,209
1442654	SCR/236	96,208
1442655	146/233	32,97,152,209
1443884	SCR/235	100,211
1446587	144/102	9,67,136,192,242,284
1446588	144/101	9,67,136,192,242,284
1451246	SCR/115	188
1452665	SCR/ 3	80,193,285
1452666	SCR/ 2	80,193,285
1452667	SCP/ 3	16,137,245
1452668	SCP/ 2	16,137,245
1457887	SCR/535	52,53,120,121,174,175, 232,233,272,273,312,313
1457888	SCR/534	52,53,120,121,174,175, 232,233,272,273,312,313
1457895	SCR/529	50,51,116,117,170,171, 228,229,270,271,310,311
1457896	SCR/528	50,51,116,117,170,171, 228,229,270,271,310,311
1457919	SCR/537	44,45,110,111, 164,165,222,223
1457920	SCR/536	44,45,110,111, 164,165,222,223
1457921	SCR/537	44,45,110,111, 164,165,222,223
1457922	SCR/536	44,45,110,111, 164,165,222,223
1457929	SCR/533	118,119,172,173,230,231
1457930	SCR/532	118,119,172,173,230,231
1459133	SCR/146	189,19
1459134	SCR/147	135,189,190
1459135	SCR/148	135,189,190
1459141	SCR/151	132,133,186,190
1459142	SCR/152	132,133,186,190

Cod. Originale O.E.M. Ref. OE Nummer	Cod. Covind Covind Ref. Covind Teilnummer	Pag.Cat. Page Cat. Seite
1459145	SCR/141	187,19
1459146	SCR/131	133
1459488	SCR/140	187,19
1466031	SCR/144	189,19
1466032	SCR/143	189,19
1466034	SCP/142	135
1466035	SCP/141	135
1467000	144/102	9,67,136,192,242,284
1467003	144/101	9,67,136,192,242,284
1471599	SCR/235	100,211
1472832	144/ 10	17,81,138,194,286
1472833	144/ 11	17,81,138,194,286
1476532	SCP/ 3	16,137,245
1476533	SCP/ 2	16,137,245
1476534	SCR/ 3	80,193,285
1476535	SCR/ 2	80,193,285
1479924	144/220	37,103,156,215,263,303
1482069	094/ 90	238
1482070	144/100	278
1482404	SCR/620	124,236
1482405	SCR/619	124,236
1485072	144/196	16,80,137,193,245,285
1485485	144/200	36,102,155,214,262,302
1485485	SCR/204	-
1485486	144/204	37,103,156,215,263,303
1485486	SCR/200	-
1486647	146/235	33,98,211
1486648	SCR/238	153,21
1488409	144/195	16,80,137,193,245,285
1488410	144/194	16,80,137,193,245,285
1495577	SCR/ 89	128,182
1495578	SCR/ 88	128,182
1495956	SCR/165	73,191
1495957	SCR/164	73,191

OEMCOVIND

Tabella Comparative :: Cross References :: Korrespondenztabelle

Cod. Originale O.E.M. Ref. OE Nummer	Cod. Covind Covind Ref. Covind Teilnummer	Pag.Cat. Page Cat. Seite
1496293	SCP/165	14
1496294	SCP/164	14
1496659	144/500	212,265,304
1498179	SCR/231	32,97,152,209
1498180	SCR/230	32,96,152,208
1499230	144/100	278
1499231	094/ 90	238
1501342	SCR/239	153,211
1501343	SCR/238	153,21
1502409	146/236	33,98
1503181	146/238	210
1504131	SCR/ 90	128,182
1512423	SCR/243	35,100,154,212
1512424	SCR/242	35,100,154,212
1515190	094/ 90	238
1515194	144/230	260,3
1515195	144/231	260,3
1517649	144/203	36,102,155,214,262,302
1517650	144/202	36,102,155,214,262,302
1523508	SCR/ 97	3,60,129,183
1523509	SCR/ 96	3,60,129,183
1523881	SCR/ 99	3,60,130,184
1523882	SCR/ 98	3,60,130,184
1529070	144/104	238,279
1529071	144/103	238,279
1535035	144/217	261,301
1535036	144/216	261,301
1535039	SCR/217	-
1535045	144/215	261,301
1535048	SCR/215	35,100,154,212
1535049	144/212	261,301
1535052	SCR/212	35,100,154,212
1536789	144/500	212,265,304
1536807	SCR/150	132,133,186,190

Cod. Originale O.E.M. Ref. OE Nummer	Cod. Covind Covind Ref. Covind Teilnummer	Pag.Cat. Page Cat. Seite
1537675	094/160	244
1538383	SCR/145	188,19
1538384	SCR/161	73,191,276
1538385	SCR/160	73,191
1543307	SCR/135	132,186
1543308	SCR/134	132,186
1543607	SCP/145	134
1543608	SCP/161	14
1543609	SCP/160	14
1543634	144/155	242,284
1543635	144/154	242,284
1544330	144/195	16,80,137,193,245,285
1544331	144/194	16,80,137,193,245,285
1721731	SCR/115	188
1721891	SCR/531	42,43,108,109, 162,163,220,221
1721892	SCR/530	42,43,108,109, 162,163,220,221
1721893	SCR/527	48,49,114,115, 168,169,226,227
1721894	SCR/526	48,49,114,115, 168,169,226,227
1723518	144/505	22,86,142,198,250,290
1723519	144/506	24,88,144,200,252,292
1725663	SCR/535	52,53,120,121,174,175, 232,233,272,273,312,313
1725664	SCR/534	52,53,120,121,174,175, 232,233,272,273,312,313
1725671	SCR/529	50,51,116,117,170,171, 228,229,270,271,310,311
1725672	SCR/528	50,51,116,117,170,171, 228,229,270,271,310,311
1726850	144/159	244,28
1726851	144/158	244,28

Cod. Originale O.E.M. Ref. OE Nummer	Cod. Covind Covind Ref. Covind Teilnummer	Pag.Cat. Page Cat. Seite
1727991	SCR/159	136,192
1727992	SCR/158	136,192
1731206	SCR/100	127,181
1732509	144/102	9,67,136,192,242,284
1732510	144/101	9,67,136,192,242,284
1732782*	144/511	26,30,90,94,146,150, 202,206,254,258,294,298
1732783*	144/510	24,28,88,92,144,148, 200,204,252,256,292,296
1737413	SCR/506	34,99,153,210
1739739	SCP/ 3	16,137,245
1739740	SCR/ 3	80,193,285
1739742	SCP/ 2	16,137,245
1739743	SCR/ 2	80,193,285
1742264	SCR/135	132,186
1742265	SCR/134	132,186
1742377	SCR/535	52,53,120,121,174,175, 232,233,272,273,312,313
1742378	SCR/534	52,53,120,121,174,175, 232,233,272,273,312,313
1742385	SCR/529	50,51,116,117,170,171, 228,229,270,271,310,311
1742386	SCR/528	50,51,116,117,170,171, 228,229,270,271,310,311
1743176	SCR/140	187,19
1743177	SCR/130	133
1746585	SCR/115	188
1746586	SCP/110	15,134
1748085	SCR/140	187,19
1748086	SCR/130	133
1749716	SCR/165	73,191
1749717	SCR/164	73,191
1749953	144/106	243,283
1751405	SCR/161	73,191,276

OEMCOVIND

Tabelle Comparative :: Cross References :: Korrespondenztabelle

Cod. Originale O.E.M. Ref. OE Nummer	Cod. Covind Covind Ref. Covind Teilnummer	Pag.Cat. Page Cat. Seite
1751406	SCR/160	73,191
1751661	SCP/110	15,134
1755594	SCR/145	188,19
1763296	SCR/100	127,181
1765808	144/510	24,28,88,92,144,148,200, 204,252,256,292,296
1765809	144/511	26,30,90,94,146,150, 202,206,254,258,294,298
1765985	144/501	21,23,25,27,29,31,85,87, 89,91,93,95,141,143,145, 147,149,151,197,199,201, 203,205,207,249,251,253, 255,257,259,289,291,293, 295,297,299
1767265	144/502	25,27,29,31,89,91,93,95, 145,147,149,151,201,203, 205,207,253,255,257,259, 293,295,297,299
1779113	146/211	97,209
1779114	146/210	96,208
1779118	SCR/239	153,211
1779119	SCR/238	153,21
1779120	146/235	33,98,211
1779121	146/234	33,98,210
1785530	SCR/620	124,236
1785531	SCR/619	124,236
1786692	SCR/ 99	3,60,130,184
1786693	SCR/ 98	3,60,130,184
1787895	146/238	210
1787896	146/236	33,98
1789305	144/181	246
1789306	144/180	246
1789311	144/187	17,81,138,194,246,286
1789312	144/186	17,81,138,194,246,286

Cod. Originale O.E.M. Ref. OE Nummer	Cod. Covind Covind Ref. Covind Teilnummer	Pag.Cat. Page Cat. Seite
1790006	SCR/155	9,67,136,192
1790007	SCR/154	9,67,136,192
1798863	SCR/165	73,191
1798864	SCR/164	73,191
1804628	SCR/115	188
1805341	146/233	32,97,152,209
1805342	146/232	32,96,152,208
1805447	SCR/215	35,100,154,212
1853187	SCR/232	5,58,127,181
1853193	SCR/193	130,184
1853194	SCR/192	130,184
1853196	SCR/190	59,130,131,184,185
1853346	SCR/ 95	131,185
1853347	SCR/ 94	131,185
1854227	SCR/231	32,97,152,209
1854228	SCR/230	32,96,152,208
1855910	SCP/ 50	15,134
1856472	SCP/164	14
1856473	SCP/165	14
1856474	SCR/164	73,191
1856475	SCR/165	73,191
1856476	146/162	73,191
1856477	146/163	73,191
1857591	144/ 9	18,82,139,195,247,287
1858803	SCP/110	15,134
1859174	146/115	72
1865178	146/ 91	6,7,63,64
1865181	146/ 90	4,7,61,64
1865182	146/195	2,8,65
1865183	146/194	2,65
1865186	146/ 84	6,63
1865188	146/ 85	4,61
1865517	144/115	17,81,138,194,286
1865519	144/115	17,81,138,194,286

Cod. Originale O.E.M. Ref. OE Nummer	Cod. Covind Covind Ref. Covind Teilnummer	Pag.Cat. Page Cat. Seite
1865520	144/114	17,81,138,194,286
1865521	144/114	17,81,138,194,286
1867654	144/187	17,81,138,194,246,286
1867655	144/186	17,81,138,194,246,286
1870592	146/146	76
1870593	146/147	76
1870594	146/148	14,76
1870595	146/144	73
1870596	146/143	73
1870597	146/141	78
1870598	146/151	11,69
1870599	146/152	11,69
1870689	144/140	241,282
1871667	146/135	10,68
1872158	146/145	72
1872159	146/140	78
1872160	146/130	79
1873210	146/ 90	4,7,61,64
1875843	146/255	12,7
1875846	146/258	13,71
1875847	146/259	13,71
1875851	146/150	10,68
1875858	146/850	12,7
1880736	SCR/145	188,19
1880737	SCR/147	135,189,190
1884482	146/ 81	7,64
1884483	146/ 80	7,64
1884485	146/133	4,7,61,64
1884486	146/132	4,7,61,64
1884914	146/ 95	59
1884915	146/ 94	59
1885932	146/250	68
1885940	146/265	12,7
1885944	146/205	68

OEMCOVIND

Tabella Comparative :: Cross References :: Korrespondenztabelle

Cod. Originale O.E.M. Ref. OE Nummer	Cod. Covind Covind Ref. Covind Teilnummer	Pag.Cat. Page Cat. Seite
1885949	146/855	12,7
1885996	146/134	6,7,63,64
1890176	146/131	79
1900633	146/159	12,7
1900634	146/159	12,7
1900635	146/159	12,7
1900636	146/159	12,7
1902975	144/181	246
1902976	144/180	246
1904301	146/120	79
1904301	146/121	15
1904302	146/120	79
1904302	146/121	15
1904303	146/120	79
1904304	146/120	79
1904305	146/120	79
1904305	146/121	15
1904306	146/120	79
1904306	146/121	15
1904814	SCP/110	15,134
1917216	146/115	72
1923152	SCR/190	59,130,131,184,185
1923742	146/193	5,65
1923743	146/192	5,65
1923744	146/ 93	62
1923745	146/ 92	62
1926448	146/196	8,66
1927257	SCR/531	42,43,108,109, 162,163,220,221
1927258	SCR/530	42,43,108,109, 162,163,220,221
1929904	146/198	66
1930649	144/ 9	18,82,139,195,247,287
1930792	146/846	77

Cod. Originale O.E.M. Ref. OE Nummer	Cod. Covind Covind Ref. Covind Teilnummer	Pag.Cat. Page Cat. Seite
1930793	146/847	77
1930794	146/848	77
1930799	146/841	78
1930805	146/851	11,69
1930806	146/852	11,69
1930811	146/853	13,71
1930812	146/854	13,71
1931613	146/ 89	-
1931614	146/ 88	-
1936674	SCR/155	9,67,136,192
1936675	SCR/154	9,67,136,192
1942252	SCR/525	46,47,112,113, 166,167,224,225
1942253	SCR/524	46,47,112,113, 166,167,224,225
2000390	SCR/506	34,99,153,210
2005369	144/195	16,80,137,193,245,285
2005370	144/194	16,80,137,193,245,285
2008861	SCP/110	15,134
2026619	SCR/522	106,160,218,268,308
2026621	SCR/522	106,160,218,268,308
2031054	146/ 89	-
2031055	146/ 88	-
2031866	SCP/ 50	15,134
2052117	SCR/505	34,99,153,211
2054579	SCR/527	48,49,114,115, 168,169,226,227
2054580	SCR/526	48,49,114,115, 168,169,226,227
2054581	SCR/531	42,43,108,109, 162,163,220,221
2054582	SCR/530	42,43,108,109, 162,163,220,221
2054589	SCR/525	46,47,112,113,

Cod. Originale O.E.M. Ref. OE Nummer	Cod. Covind Covind Ref. Covind Teilnummer	Pag.Cat. Page Cat. Seite
2054589	SCR/525	166,167,224,225
2054590	SCR/524	46,47,112,113, 166,167,224,225
2054601	SCR/535	52,53,120,121,174,175, 232,233,272,273,312,313
2054602	SCR/534	52,53,120,121,174,175, 232,233,272,273,312,313
2054603	SCR/529	50,51,116,117,170,171, 228,229,270,271,310,311
2054604	SCR/528	50,51,116,117,170,171, 228,229,270,271,310,311
2055972	146/160	74
2055973	146/161	74
2056867	144/516	38,40,104,106,158,160, 216,218,266,268,306,308
2057119	SCR/535	52,53,120,121,174,175, 232,233,272,273,312,313
2057120	SCR/534	52,53,120,121,174,175, 232,233,272,273,312,313
2080828	SCR/506	34,99,153,210
2093720	SCR/620	124,236
2093721	SCR/619	124,236
2097976	146/867	75
2097977	146/866	75
2124011	SCP/159	9,67,136,192
2124015	SCR/157	67,192
2126392	146/ 91	6,7,63,64
2126955	146/165	75
2126956	146/164	75
2127431	146/ 89	-
2127432	146/ 88	-
2145647	144/195	16,80,137,193,245,285
2145648	144/194	16,80,137,193,245,285
2146221	146/120	79

Cod. Covind Covind Ref. Covind Teilnummer	Cod. Originale O.E.M. Ref. OE Nummer	Pag.Cat. Page Cat. Seite
092/145	1317537	334
092/145	1123519	334
092/145	303080	334
092/145	389048	334
092/160	280378	334
092/161	280377	334
092/230	1338366	322,338
092/230	343108	322,338
092/231	1338365	322,338
092/231	343107	322,338
093/145	1317538	318
093/145	1123520	318
094/ 90	1515190	238
094/ 90	1336013	238
094/ 90	1376832	238
094/ 90	1482069	238
094/ 90	1499231	238
094/ 94	1375458	238
094/ 95	1375457	238
094/136	1393447	240
094/136	1366288	240
094/136	1383888	240
094/137	1383887	240
094/137	1366287	240
094/145	1397571	239
094/145	1371857	239
094/146	1401931	239
094/147	1371754	239
094/160	1386958	244
094/160	1537675	244
094/161	1386957	244
094/162	1370108	244
094/163	1370107	244
094/164	1386960	244

Cod. Covind Covind Ref. Covind Teilnummer	Cod. Originale O.E.M. Ref. OE Nummer	Pag.Cat. Page Cat. Seite
094/165	1386959	244
142/ 6	1109952	326,342
142/ 7	1109951	326,342
142/ 9	356942	327,343
142/ 25	316640	326,342
142/ 94	316756	341
142/ 96	316756	341
142/100	1300831	319,324,335,341
142/100	322928	319,324,335,341
142/100	370990	319,324,335,341
142/144	303076	325,34
142/160	281378	340
142/161	281377	340
142/164	524784	327,343
142/164	336980	327,343
142/165	524783	327,343
142/165	336979	327,343
142/166	376116	327,343
142/166	296206	327,343
142/170	356540	327,343
142/172	336938	327,343
142/172	296028	327,343
142/174	524796	327,343
142/174	336760	327,343
142/175	524795	327,343
142/175	336759	327,343
142/177	524533	327,343
142/180	376284	326,342
142/181	376283	326,342
142/182	296834	327,343
142/183	296833	327,343
142/196	1306976	326,342
142/196	356084	326,342
142/196	356086	326,342

Cod. Covind Covind Ref. Covind Teilnummer	Cod. Originale O.E.M. Ref. OE Nummer	Pag.Cat. Page Cat. Seite
142/196	356087	326,342
142/197	1306975	326,342
142/197	356085	326,342
142/198	1306976	326,342
142/198	1306975	326,342
142/800	356490	325,34
143/ 90	1303318	324
143/ 90	1110301	324
143/ 90	381698	324
143/108	-	318,325,334,340
143/230	1338378	328,346
143/230	343110	328,346
143/231	1338377	328,346
143/231	343109	328,346
143/240	361020	328
143/241	361019	328
143/244	361994	322,328,338
143/245	361993	322,328,338
143/442	1308475	324
143/520	1313594	329
144/ 6	1426925	18,82,139,195,247,287
144/ 7	1422292	18,82,139,195,247,287
144/ 9	1930649	18,82,139,195,247,287
144/ 9	1426927	18,82,139,195,247,287
144/ 9	1857591	18,82,139,195,247,287
144/ 10	1472832	17,81,138,194,286
144/ 10	1346938	17,81,138,194,286
144/ 11	1472833	17,81,138,194,286
144/ 11	1346937	17,81,138,194,286
144/ 12	1346940	17,81,138,194,286
144/ 13	1346939	17,81,138,194,286
144/ 14	1346164	83,139,195,247,287
144/ 15	1346163	83,139,195,247,287
144/ 50	1306492	240,282

Cod. Covind Covind Ref. Covind Teilnummer	Cod. Originale O.E.M. Ref. OE Nummer	Pag.Cat. Page Cat. Seite
144/ 90	1400213	278
144/ 90	1324596	278
144/ 94	1324598	279
144/ 95	1324597	279
144/100	1499230	278
144/100	1395871	278
144/100	1482070	278
144/101	1732510	9,67,136,192,242,284
144/101	1431256	9,67,136,192,242,284
144/101	1446588	9,67,136,192,242,284
144/101	1467003	9,67,136,192,242,284
144/102	1732509	9,67,136,192,242,284
144/102	1431257	9,67,136,192,242,284
144/102	1446587	9,67,136,192,242,284
144/102	1467000	9,67,136,192,242,284
144/103	1529071	238,279
144/103	1358832	238,279
144/103	1400208	238,279
144/103	1422992	238,279
144/104	1529070	238,279
144/104	1358831	238,279
144/104	1400207	238,279
144/104	1422991	238,279
144/106	1749953	243,283
144/106	1379997	243,283
144/110	1383609	282
144/114	1865520	17,81,138,194,286
144/114	1366735	17,81,138,194,286
144/114	1865521	17,81,138,194,286
144/115	1865517	17,81,138,194,286
144/115	1366781	17,81,138,194,286
144/115	1865519	17,81,138,194,286
144/134	1381480	241,283
144/135	1381479	241,283

Cod. Covind Covind Ref. Covind Teilnummer	Cod. Originale O.E.M. Ref. OE Nummer	Pag.Cat. Page Cat. Seite
144/140	1870689	241,282
144/140	1366243	241,282
144/140	1366832	241,282
144/145	1397570	282
144/145	1371856	282
144/146	1401929	281
144/147	1371757	281
144/148	1371758	281
144/150	1366384	241,283
144/154	1543635	242,284
144/154	1324600	242,284
144/155	1543634	242,284
144/155	1324599	242,284
144/158	1726851	244,28
144/158	1381564	244,28
144/158	1440113	244,28
144/159	1440108	244,28
144/159	1381563	244,28
144/159	1726850	244,28
144/160	1370330	280,281
144/161	1370329	280,281
144/162	1382728	280,281
144/163	1382727	280,281
144/164	1381566	280,281
144/165	1381565	280,281
144/174	2303352	18,83,195,246,287
144/174	1366850	18,83,195,246,287
144/174	1442295	18,83,195,246,287
144/174	2162367	18,83,195,246,287
144/175	2303349	18,83,195,246,287
144/175	1366849	18,83,195,246,287
144/175	1442294	18,83,195,246,287
144/175	2162366	18,83,195,246,287
144/180	1902976	246

Cod. Covind Covind Ref. Covind Teilnummer	Cod. Originale O.E.M. Ref. OE Nummer	Pag.Cat. Page Cat. Seite
144/180	1406224	246
144/180	1789306	246
144/181	1902975	246
144/181	1406223	246
144/181	1789305	246
144/186	1867655	17,81,138,194,246,286
144/186	1789312	17,81,138,194,246,286
144/187	1867654	17,81,138,194,246,286
144/187	1789311	17,81,138,194,246,286
144/192	1346178	246
144/193	1346177	246
144/194	2145648	16,80,137,193,245,285
144/194	2005370	16,80,137,193,245,285
144/194	1423018	16,80,137,193,245,285
144/194	1488410	16,80,137,193,245,285
144/194	1544331	16,80,137,193,245,285
144/195	2145647	16,80,137,193,245,285
144/195	2005369	16,80,137,193,245,285
144/195	1423017	16,80,137,193,245,285
144/195	1488409	16,80,137,193,245,285
144/195	1544330	16,80,137,193,245,285
144/196	1485072	16,80,137,193,245,285
144/196	581025	16,80,137,193,245,285
144/200	1485485	36,102,155,214,262,302
144/200	1335391	36,102,155,214,262,302
144/200	1408465	36,102,155,214,262,302
144/202	1517650	36,102,155,214,262,302
144/202	1324606	36,102,155,214,262,302
144/202	1429394	36,102,155,214,262,302
144/203	1517649	36,102,155,214,262,302
144/203	1324605	36,102,155,214,262,302
144/203	1429393	36,102,155,214,262,302
144/204	1485486	37,103,156,215,263,303
144/204	1335392	37,103,156,215,263,303

Cod. Covind Covind Ref. Covind Teilnummer	Cod. Originale O.E.M. Ref. OE Nummer	Pag.Cat. Page Cat. Seite
144/204	1408466	37,103,156,215,263,303
144/206	1364666	37,103,156,215,263,303
144/207	1364665	37,103,156,215,263,303
144/210	1398873	36,102,155,214,262,302
144/212	1535049	261,301
144/212	1390076	261,301
144/215	1535045	261,301
144/215	1351203	261,301
144/216	1535036	261,301
144/216	1310590	261,301
144/217	1535035	261,301
144/217	1310589	261,301
144/220	1479924	37,103,156,215,263,303
144/220	1362711	37,103,156,215,263,303
144/230	1515194	260,3
144/230	1351194	260,3
144/231	1515195	260,3
144/231	1351193	260,3
144/236	1390074	260,3
144/237	1390075	260,3
144/238	1354594	261,301
144/239	1354593	261,301
144/246	1310214	264
144/247	1310203	264
144/248	1310204	264
144/249	1310213	264
144/500	1496659	212,265,304
144/500	1387870	212,265,304
144/500	1536789	212,265,304
144/501	1765985	21,23,25,27,29,31,85, 87,89,91,93,95,141,143, 145,147,149,151,197,199, 201,203,205,207,249,251, 253,255,257,259,289,291,

Cod. Covind Covind Ref. Covind Teilnummer	Cod. Originale O.E.M. Ref. OE Nummer	Pag.Cat. Page Cat. Seite
144/501	1765985	293,295,297,299
144/502	1767265	25,27,29,31,89,91,93, 95,145,147,149,151, 201,203,205,207,253, 255,257,259,293,295, 297,299
144/503	-	20,84,140,196,248,288
144/505	2425815	22,86,142,198,250,290
144/505	1723518	22,86,142,198,250,290
144/506	2425816	24,88,144,200,252,292
144/506	1723519	24,88,144,200,252,292
144/507	-	26,90,146,202,254,294
144/508	-	28,92,148,204,256,296
144/509	-	30,94,150,206,258,298
144/510	1765808	24,28,88,92,144,148, 200,204,252,256,292,296
144/510	1732783*	24,28,88,92,144,148, 200,204,252,256,292,296
144/511	1765809	26,30,90,94,146,150, 202,206,254,258,294,298
144/511	1732782*	26,30,90,94,146,150, 202,206,254,258,294,298
144/512	1346380	21,23,25,27,29,31,85, 87,89,91,93,95,141,143, 145,147,149,151,197, 199,201,203,205,207, 249,251,253,255,257, 259,289,291,293,295, 297,299
144/515	1383858	38,40,104,106,158,160, 216,218,266,268,306,308
144/516	2056867	38,40,104,106,158,160, 216,218,266,268,306,308

Cod. Covind Covind Ref. Covind Teilnummer	Cod. Originale O.E.M. Ref. OE Nummer	Pag.Cat. Page Cat. Seite
144/516	1383520	38,40,104,106,158,160, 216,218,266,268,306,308
144/518	1357600	38,39,40,41,104,105,106, 107,158,159,160,161,216, 217,218,219,266,267,268, 269,306,307,308,309
144/519	1357599	38,39,40,41,104,105,106, 107,158,159,160,161,216, 217,218,219,266,267,268, 269,306,307,308,309
144/520	1357601	38,39,104,105,158,159,216, 217,266,267,306,307,332
144/525	1395276	38,39,104,105,158,159, 216,217,266,267,306,307
144/530	1357602	40,41,106,107,160,161, 218,219,268,269,308,309
144/600	-	281
144/601	-	281
144/800	1366851	243,283
146/ 80	1884483	7,64
146/ 81	1884482	7,64
146/ 84	1865186	6,63
146/ 85	1865188	4,61
146/ 88	2127432	-
146/ 88	1931614	-
146/ 88	2031055	-
146/ 89	2127431	-
146/ 89	1931613	-
146/ 89	2031054	-
146/ 90	1865181	4,7,61,64
146/ 90	1873210	4,7,61,64
146/ 91	2126392	6,7,63,64
146/ 91	1865178	6,7,63,64
146/ 92	1923745	62

Cod. Covind Covind Ref. Covind Teilnummer	Cod. Originale O.E.M. Ref. OE Nummer	Pag.Cat. Page Cat. Seite	Cod. Covind Covind Ref. Covind Teilnummer	Cod. Originale O.E.M. Ref. OE Nummer	Pag.Cat. Page Cat. Seite	Cod. Covind Covind Ref. Covind Teilnummer	Cod. Originale O.E.M. Ref. OE Nummer	Pag.Cat. Page Cat. Seite
146/ 93	1923744	62	146/145	1872158	72	146/235	1486647	33,98,211
146/ 94	1884915	59	146/146	1870592	76	146/236	1787896	33,98
146/ 95	1884914	59	146/147	1870593	76	146/236	1502409	33,98
146/115	2269451	72	146/148	1870594	14,76	146/238	1787895	210
146/115	1859174	72	146/150	1875851	10,68	146/238	1503181	210
146/115	1917216	72	146/151	1870598	11,69	146/250	1885932	68
146/120	-	79	146/152	1870599	11,69	146/255	1875843	12,7
146/120	2146221	79	146/159	-	12,7	146/258	1875846	13,71
146/120	2146222	79	146/159	1900633	12,7	146/259	1875847	13,71
146/120	1904301	79	146/159	1900634	12,7	146/265	1885940	12,7
146/120	1904302	79	146/159	1900635	12,7	146/841	1930799	78
146/120	1904303	79	146/159	1900636	12,7	146/846	1930792	77
146/120	1904304	79	146/160	2055972	74	146/847	1930793	77
146/120	1904305	79	146/161	2055973	74	146/848	1930794	77
146/120	1904306	79	146/162	1856476	73,191	146/850	1875858	12,7
146/121	-	15	146/163	1856477	73,191	146/851	1930805	11,69
146/121	2146221	15	146/164	2126956	75	146/852	1930806	11,69
146/121	2146222	15	146/165	2126955	75	146/853	1930811	13,71
146/121	1904301	15	146/166	2162653	75	146/854	1930812	13,71
146/121	1904302	15	146/167	2162652	75	146/855	1885949	12,7
146/121	1904305	15	146/192	1923743	5,65	146/866	2097977	75
146/121	1904306	15	146/193	1923742	5,65	146/867	2097976	75
146/130	1872160	79	146/194	1865183	2,65	SCP/ 2	1476533	16,137,245
146/131	1890176	79	146/195	1865182	2,8,65	SCP/ 2	1452668	16,137,245
146/132	1884486	4,7,61,64	146/196	1926448	8,66	SCP/ 2	1739742	16,137,245
146/133	1884485	4,7,61,64	146/198	1929904	66	SCP/ 3	1476532	16,137,245
146/134	1885996	6,7,63,64	146/205	1885944	68	SCP/ 3	1452667	16,137,245
146/135	1871667	10,68	146/210	1779114	96,208	SCP/ 3	1739739	16,137,245
146/138	2246330	74	146/211	1779113	97,209	SCP/ 50	2031866	15,134
146/139	2246329	74	146/232	1805342	32,96,152,208	SCP/ 50	1855910	15,134
146/140	1872159	78	146/233	1805341	32,97,152,209	SCP/110	2008861	15,134
146/141	1870597	78	146/233	1442655	32,97,152,209	SCP/110	1746586	15,134
146/143	1870596	73	146/234	1779121	33,98,210	SCP/110	1751661	15,134
146/144	1870595	73	146/235	1779120	33,98,211	SCP/110	1858803	15,134

Cod. Covind Covind Ref. Covind Teilnummer	Cod. Originale O.E.M. Ref. OE Nummer	Pag.Cat. Page Cat. Seite
SCP/110	1904814	15,134
SCP/141	1466035	135
SCP/142	1466034	135
SCP/145	1543607	134
SCP/158	1438564	9,67,136,192
SCP/159	2124011	9,67,136,192
SCP/159	1438563	9,67,136,192
SCP/160	2165864	14
SCP/160	1543609	14
SCP/161	2165863	14
SCP/161	1543608	14
SCP/164	1856472	14
SCP/164	1496294	14
SCP/165	1856473	14
SCP/165	1496293	14
SCR/ 2	1476535	80,193,285
SCR/ 2	1452666	80,193,285
SCR/ 2	1739743	80,193,285
SCR/ 3	1476534	80,193,285
SCR/ 3	1452665	80,193,285
SCR/ 3	1739740	80,193,285
SCR/ 50	1435542	72,188
SCR/ 88	1495578	128,182
SCR/ 89	1495577	128,182
SCR/ 90	1504131	128,182
SCR/ 92	1439789	129,183
SCR/ 93	1439788	129,183
SCR/ 94	1853347	131,185
SCR/ 94	1431926	131,185
SCR/ 95	1853346	131,185
SCR/ 95	1431925	131,185
SCR/ 96	1523509	3,60,129,183
SCR/ 97	1523508	3,60,129,183
SCR/ 98	1786693	3,60,130,184

Cod. Covind Covind Ref. Covind Teilnummer	Cod. Originale O.E.M. Ref. OE Nummer	Pag.Cat. Page Cat. Seite
SCR/ 98	1523882	3,60,130,184
SCR/ 99	1786692	3,60,130,184
SCR/ 99	1523881	3,60,130,184
SCR/100	1763296	127,181
SCR/100	1422843	127,181
SCR/100	1731206	127,181
SCR/115	1804628	188
SCR/115	1451246	188
SCR/115	1721731	188
SCR/115	1746585	188
SCR/130	1748086	133
SCR/130	1743177	133
SCR/131	1459146	133
SCR/134	1742265	132,186
SCR/134	1543308	132,186
SCR/135	1742264	132,186
SCR/135	1543307	132,186
SCR/140	1748085	187,19
SCR/140	1459488	187,19
SCR/140	1743176	187,19
SCR/141	1459145	187,19
SCR/142	-	190
SCR/143	1466032	189,19
SCR/144	1466031	189,19
SCR/145	1880736	188,19
SCR/145	1538383	188,19
SCR/145	1755594	188,19
SCR/146	1459133	189,19
SCR/147	1880737	135,189,190
SCR/147	1459134	135,189,190
SCR/148	1459135	135,189,190
SCR/149	-	190
SCR/150	1536807	132,133,186,190
SCR/151	1459141	132,133,186,190

Cod. Covind Covind Ref. Covind Teilnummer	Cod. Originale O.E.M. Ref. OE Nummer	Pag.Cat. Page Cat. Seite
SCR/152	1459142	132,133,186,190
SCR/153	-	133,19
SCR/154	1936675	9,67,136,192
SCR/154	1431921	9,67,136,192
SCR/154	1790007	9,67,136,192
SCR/155	1936674	9,67,136,192
SCR/155	1431920	9,67,136,192
SCR/155	1790006	9,67,136,192
SCR/156	1431923	67,192
SCR/157	2124015	67,192
SCR/157	1431922	67,192
SCR/158	1727992	136,192
SCR/158	1438558	136,192
SCR/159	1727991	136,192
SCR/159	1438557	136,192
SCR/160	1751406	73,191
SCR/160	1538385	73,191
SCR/161	1751405	73,191,276
SCR/161	1538384	73,191,276
SCR/164	1856474	73,191
SCR/164	1495957	73,191
SCR/164	1749717	73,191
SCR/164	1798864	73,191
SCR/165	1856475	73,191
SCR/165	1495956	73,191
SCR/165	1749716	73,191
SCR/165	1798863	73,191
SCR/190	1923152	59,130,131,184,185
SCR/190	1853196	59,130,131,184,185
SCR/192	1853194	130,184
SCR/193	1853193	130,184
SCR/194	-	16,80,137,193,245,285
SCR/195	-	16,80,137,193,245,285
SCR/200	1485486	-

Cod. Covind Covind Ref. Covind Teilnummer	Cod. Originale O.E.M. Ref. OE Nummer	Pag.Cat. Page Cat. Seite
SCR/202	1431932	102,214
SCR/203	1431931	102,214
SCR/204	1485485	-
SCR/206	1431934	103,215
SCR/207	1431933	103,215
SCR/212	1535052	35,100,154,212
SCR/215	1805447	35,100,154,212
SCR/215	1535048	35,100,154,212
SCR/217	1535039	-
SCR/230	1854228	32,96,152,208
SCR/230	1498180	32,96,152,208
SCR/231	1854227	32,97,152,209
SCR/231	1498179	32,97,152,209
SCR/232	1431585	5,58,127,181
SCR/232	1853187	5,58,127,181
SCR/233	1431584	5,58,127,181
SCR/235	1471599	100,211
SCR/235	1391144	100,211
SCR/235	1443884	100,211
SCR/236	1442654	96,208
SCR/237	1442653	97,209
SCR/238	1779119	153,21
SCR/238	1486648	153,21
SCR/238	1501343	153,21
SCR/239	1779118	153,211
SCR/239	1501342	153,211
SCR/242	1512424	35,100,154,212
SCR/243	1512423	35,100,154,212
SCR/505	2052117	34,99,153,211
SCR/505	1362707	34,99,153,211
SCR/506	2080828	34,99,153,210
SCR/506	1737413	34,99,153,210
SCR/506	2000390	34,99,153,210
SCR/522	2026621	106,160,218,268,308

Cod. Covind Covind Ref. Covind Teilnummer	Cod. Originale O.E.M. Ref. OE Nummer	Pag.Cat. Page Cat. Seite
SCR/522	1368652	106,160,218,268,308
SCR/522	2026619	106,160,218,268,308
SCR/523	1362708	106,160,218,268,308
SCR/524	2054590	46,47,112,113, 166,167,224,225
SCR/524	1942253	46,47,112,113, 166,167,224,225
SCR/525	2054589	46,47,112,113, 166,167,224,225
SCR/525	1942252	46,47,112,113, 166,167,224,225
SCR/526	2054580	48,49,114,115, 168,169,226,227
SCR/526	1721894	48,49,114,115, 168,169,226,227
SCR/527	2054579	48,49,114,115, 168,169,226,227
SCR/527	1721893	48,49,114,115, 168,169,226,227
SCR/528	2054604	50,51,116,117,170,171, 228,229,270,271,310,311
SCR/528	1400900	50,51,116,117,170,171, 228,229,270,271,310,311
SCR/528	1457896	50,51,116,117,170,171, 228,229,270,271,310,311
SCR/528	1725672	50,51,116,117,170,171, 228,229,270,271,310,311
SCR/528	1742386	50,51,116,117,170,171, 228,229,270,271,310,311
SCR/529	2054603	50,51,116,117,170,171, 228,229,270,271,310,311
SCR/529	1400899	50,51,116,117,170,171, 228,229,270,271,310,311
SCR/529	1457895	50,51,116,117,170,171,

Cod. Covind Covind Ref. Covind Teilnummer	Cod. Originale O.E.M. Ref. OE Nummer	Pag.Cat. Page Cat. Seite
SCR/529	1457895	228,229,270,271,310,311
SCR/529	1725671	50,51,116,117,170,171, 228,229,270,271,310,311
SCR/529	1742385	50,51,116,117,170,171, 228,229,270,271,310,311
SCR/530	2054582	42,43,108,109, 162,163,220,221
SCR/530	1721892	42,43,108,109, 162,163,220,221
SCR/530	1927258	42,43,108,109, 162,163,220,221
SCR/531	2054581	42,43,108,109, 162,163,220,221
SCR/531	1721891	42,43,108,109, 162,163,220,221
SCR/531	1927257	42,43,108,109, 162,163,220,221
SCR/532	1457930	118,119,172,173,230,231
SCR/533	1457929	118,119,172,173,230,231
SCR/534	2054602	52,53,120,121,174,175, 232,233,272,273,312,313
SCR/534	1358316	52,53,120,121,174,175, 232,233,272,273,312,313
SCR/534	1457888	52,53,120,121,174,175, 232,233,272,273,312,313
SCR/534	1725664	52,53,120,121,174,175, 232,233,272,273,312,313
SCR/534	1742378	52,53,120,121,174,175, 232,233,272,273,312,313
SCR/534	2057120	52,53,120,121,174,175, 232,233,272,273,312,313
SCR/535	2054601	52,53,120,121,174,175, 232,233,272,273,312,313
SCR/535	1358315	52,53,120,121,174,175,

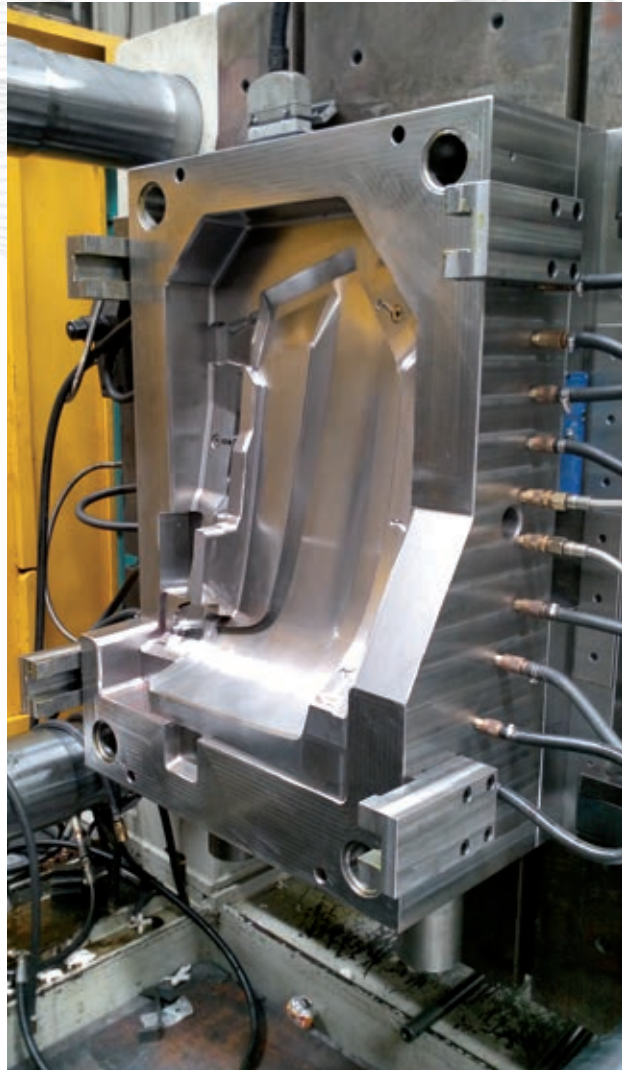
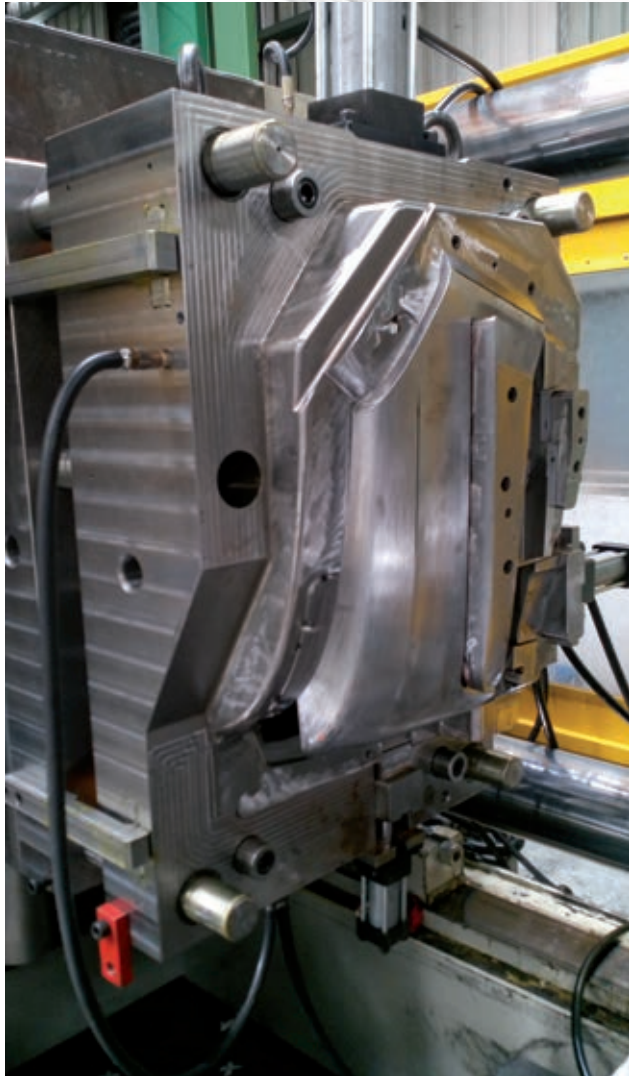

- IT Stampo in acciaio per la produzione angolare posteriore inferiore Mercedes-Benz.
EN Steel mould for the production of lower rear side bumper of Mercedes-Benz.
DE Stahlform zur Herstellung von Bus-Stoßbecken hinten für Mercedes-Benz.



- ▲
- IT Stampo (punzone) per la produzione della griglia superiore in lamiera per il veicolo Scania (Cod. Covind SCR/145)
- EN Mould (punch) for the production of the upper metal grill for the Scania vehicles (Cod. Covind SCR/145)
- DE Stahlform für die Produktion der Scania oberer Grill aus Blech (Covind Nr. SCR/145)



applicabile a | suitable to | verwendbar für

1

146

SCANIA R 2010 CP

applicabile a | suitable to | verwendbar für:

SCANIA R 2010 CP

(*) Larghezza telaio mm 1140 - chassis width 1140 mm
Chassis: Breite 1140 Millimeter (mm)

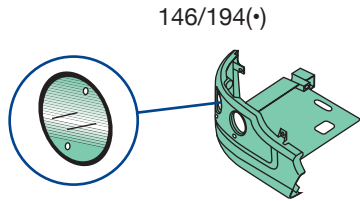
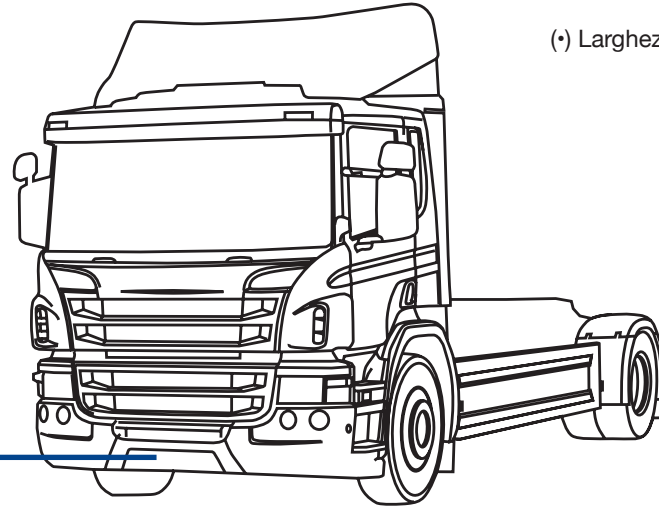

146/194(*)

940/115
protezione fendinebbia
kit 4 pz.
foglamp protection
kit 4 pcs.
Nebelscheinwerferschutz
Satz 4 st.

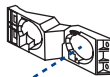
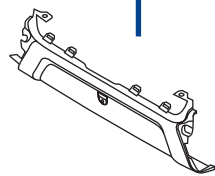

146/ 98 d-rh-rechts
146/ 99 s-lh-links

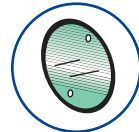

146/195(*)

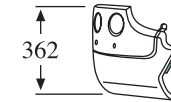

per paraurti alto
for high bumper
für hohe Stoßfänger



146/ 98
O.E.M. 2127432
146/ 99
O.E.M. 2127431



146/194
O.E.M. 1865183
146/195
O.E.M. 1865182



940/115
O.E.M. -

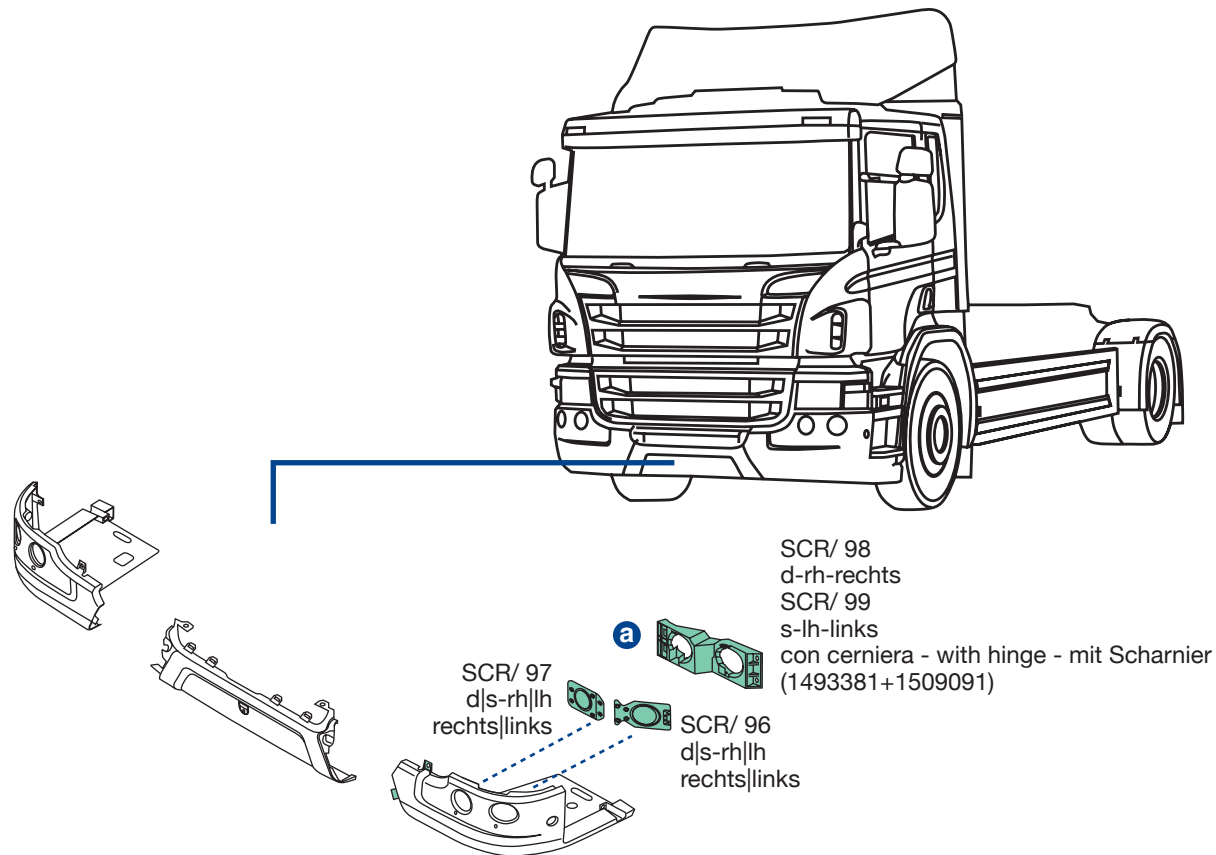

SCR/ 96
O.E.M. 1523509



SCR/ 97
O.E.M. 1523508



SCR/ 98
O.E.M. 1786693
SCR/ 99
O.E.M. 1786692

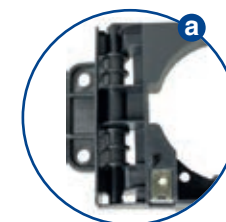

applicabile a | suitable to | verwendbar für:

SCANIA R 2010 CP

(1) Predisposto per Active Cruise Control - Active Cruise Control suitable
mit aktiven Abstandwarner

(*) Larghezza telaio mm 1020 - chassis width 1020 mm
Chassis: Breite 1020 Millimeter (mm)

(•) Larghezza telaio mm 1140 - chassis width 1140 mm
Chassis: Breite 1140 Millimeter (mm)

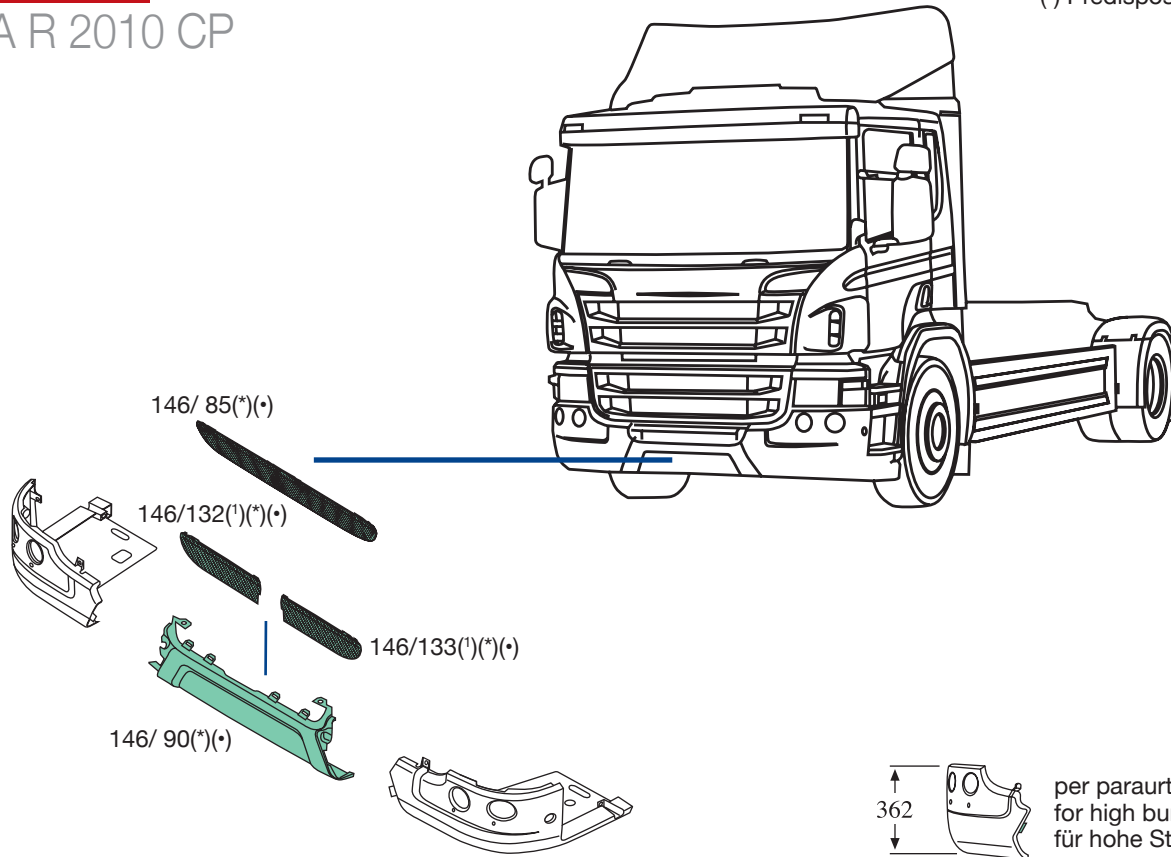

146/85
O.E.M. 1865188



146/90
O.E.M. 1865181



146/132
O.E.M. 1884486



146/133
O.E.M. 1884485

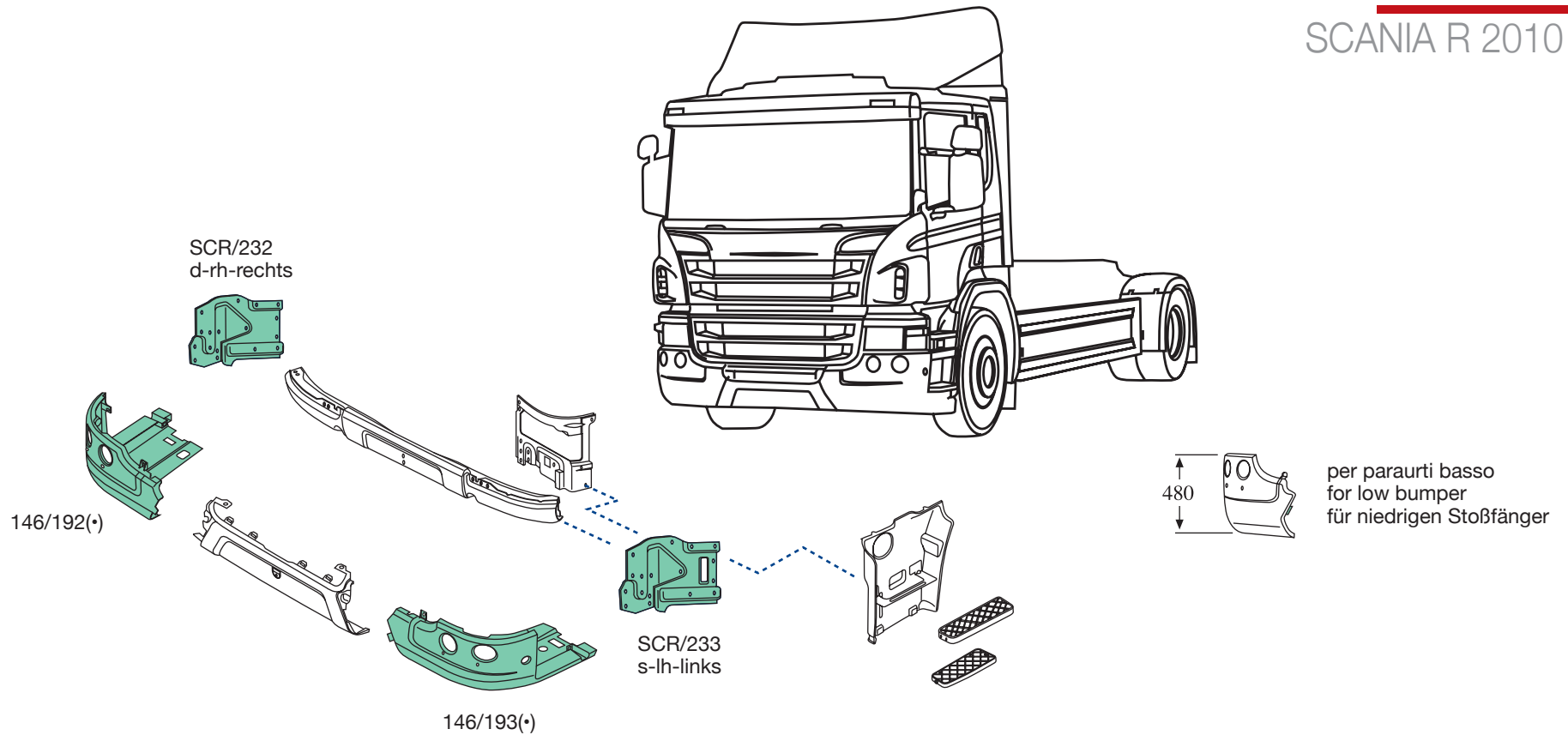

146/192
O.E.M. 1923743
146/193
O.E.M. 1923742



SCR/232
O.E.M. 1431585

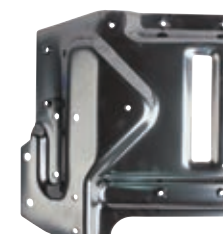

SCR/233
O.E.M. 1431584

applicabile a | suitable to | verwendbar für:

SCANIA R 2010 CP

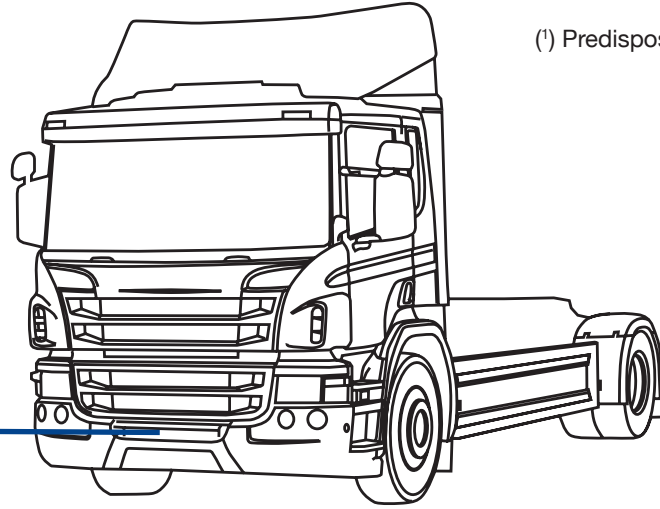

- (1) Predisposto per Active Cruise Control - Active Cruise Control suitable mit aktiven Abstandwarner
- (*) Larghezza telaio mm 1020 - chassis width 1020 mm Chassis: Breite 1020 Millimeter (mm)
- (•) Larghezza telaio mm 1140 - chassis width 1140 mm Chassis: Breite 1140 Millimeter (mm)

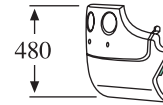
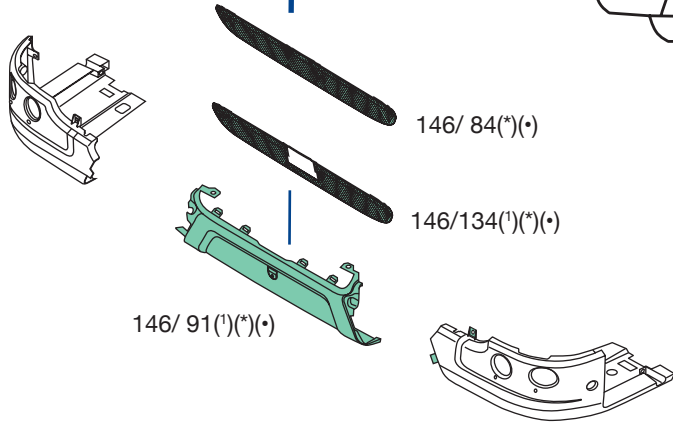

per paraurti basso
for low bumper
für niedrigen Stoßfänger



146/ 84
O.E.M. 1865186



146/ 91
O.E.M. 2126392



146/134
O.E.M. 1885996

- (1) Predisposto per Active Cruise Control - Active Cruise Control suitable
mit aktiven Abstandwarner
- (*) Larghezza telaio mm 1020 - chassis width 1020 mm
Chassis: Breite 1020 Millimeter (mm)
- (•) Larghezza telaio mm 1140 - chassis width 1140 mm
Chassis: Breite 1140 Millimeter (mm)

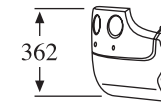
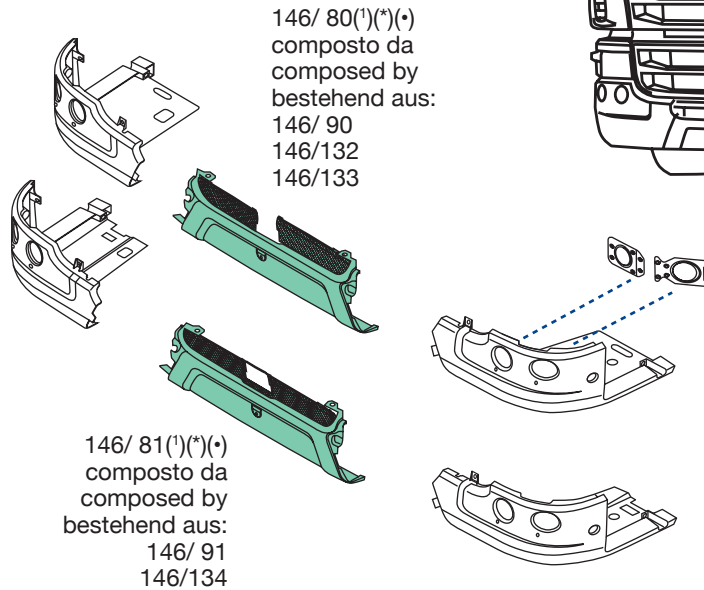
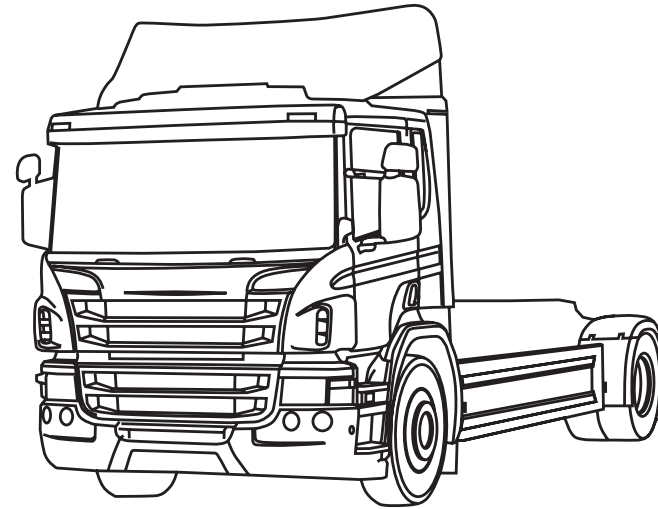

per paraurti alto
for high bumper
für hohe Stoßfänger

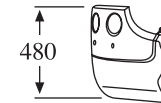

per paraurti basso
for low bumper
für niedrigen Stoßfänger



146/ 80
O.E.M. 1884483



146/ 81
O.E.M. 1884482

applicabile a | suitable to | verwendbar für:

SCANIA R 2010 CP

(*) Larghezza telaio mm 1140 - chassis width 1140 mm
Chassis: Breite 1140 Millimeter (mm)

940/115
protezione fendinebbia
kit 4 pz.
foglamp protection
kit 4 pcs.
Nebelscheinwerferschutz
Satz 4 st.

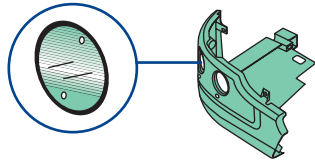

146/196(*)

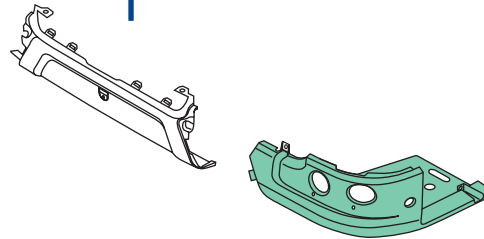

146/195(*)

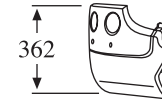

per paraurti alto
for high bumper
für hohe Stoßfänger



146/196
O.E.M. 1926448
146/195
O.E.M. 1865182



940/115
O.E.M. -

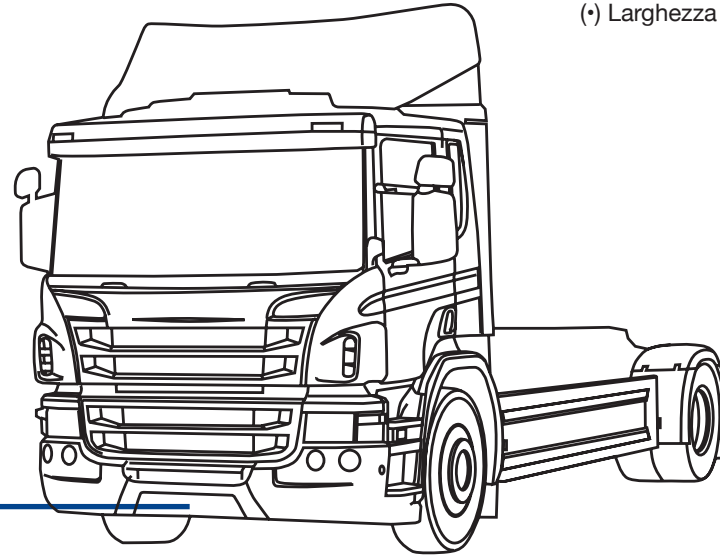

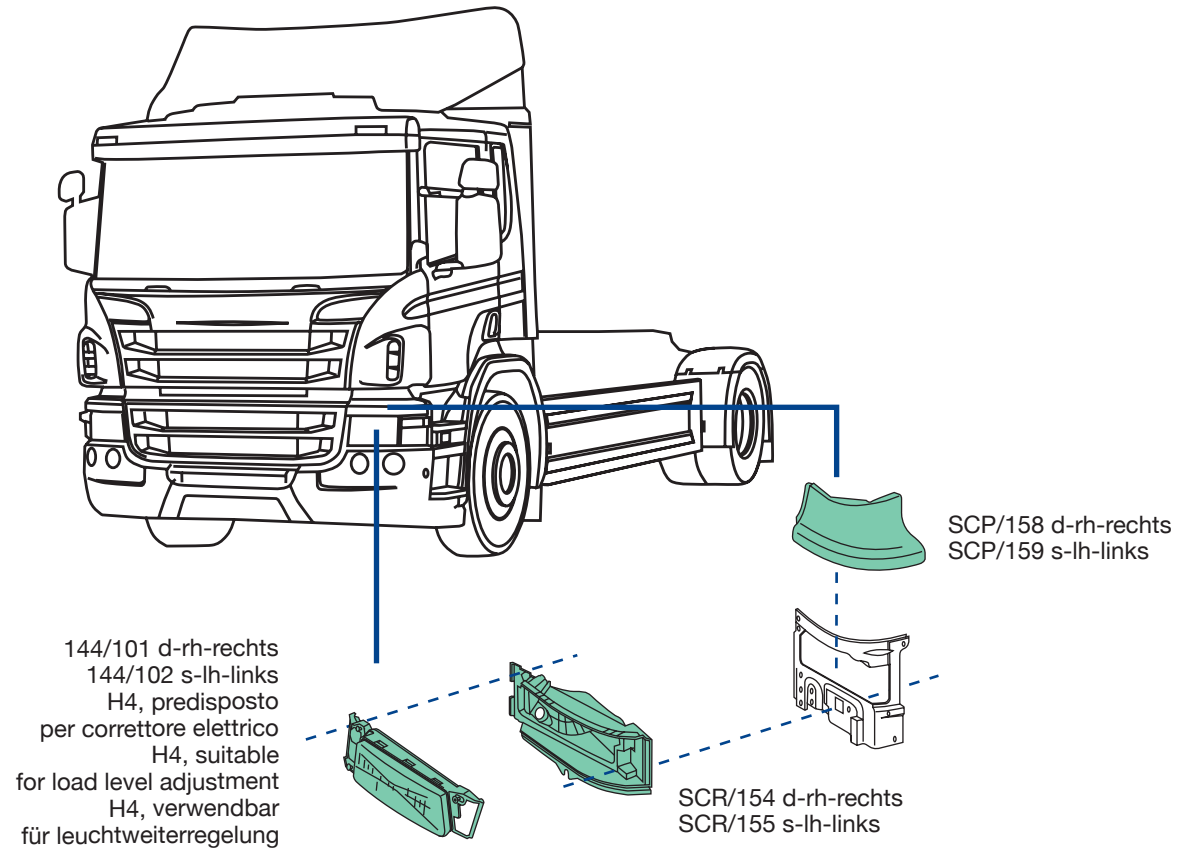

144/101
O.E.M. 1732510
144/102
O.E.M. 1732509



SCR/154
O.E.M. 1936675
SCR/155
O.E.M. 1936674



SCP/158
O.E.M. 1438564
SCP/159
O.E.M. 2124011

applicabile a | suitable to | verwendbar für:

SCANIA R 2010 CP

(°) Per paraurti basso - for low bumper - für niedrigen Stoßfänger

(*) Larghezza telaio mm 1020 - chassis width 1020 mm

Chassis: Breite 1020 Millimeter (mm)

146/135(°)(*)
senza fori per pedana supplementare
without holes for additional step panel
ohne Ausschnitte für zusätzliche Fussplatte
L=1520 H=380 I=950

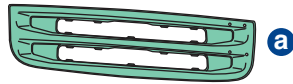
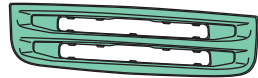

146/150(°)(*)
con fori per pedana supplementare
with holes for additional step panel
mit Ausschnitte für zusätzliche Fussplatte
L=1520 H=380 I=950

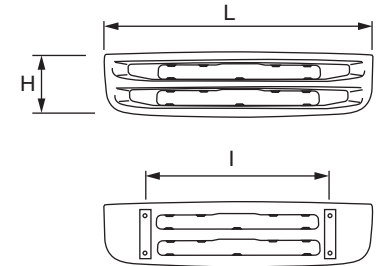
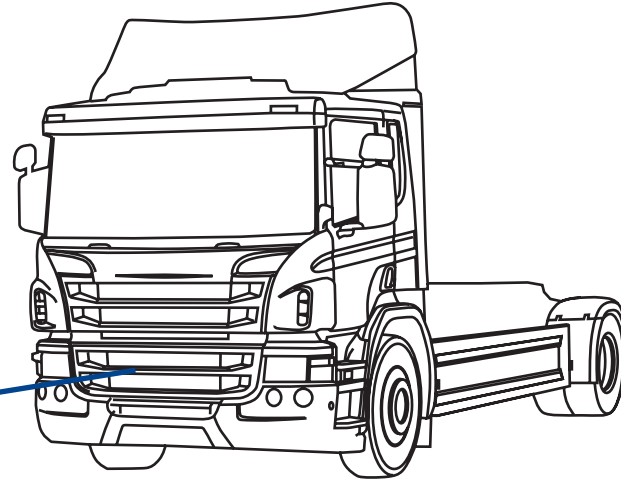

146/135
O.E.M. 1871667



146/150
O.E.M. 1875851

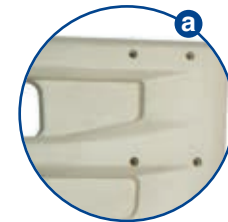

(a) Variante V8 - fori Ø 8mm | V8 Version - holes Ø 8mm | V8 Version - Ø 8mm Löcher

applicabile a | suitable to | verwendbar für:

SCANIA R 2010 CP

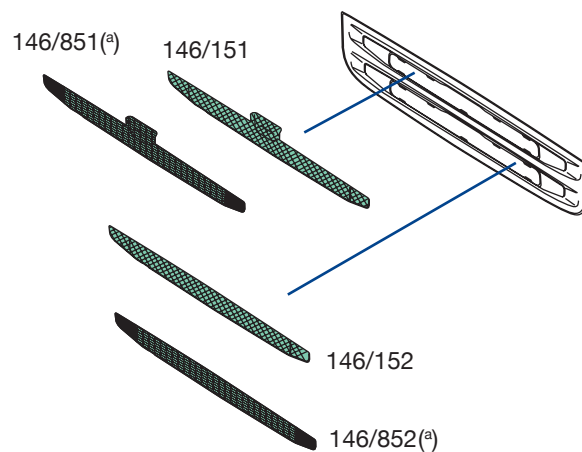
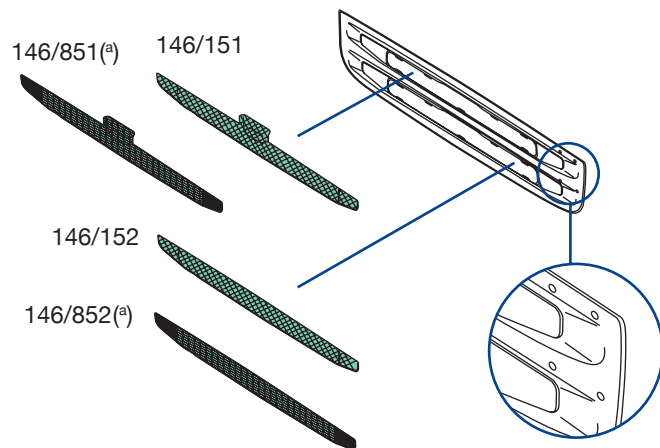

146/151
O.E.M. 1870598



146/152
O.E.M. 1870599



146/851
O.E.M. 1930805

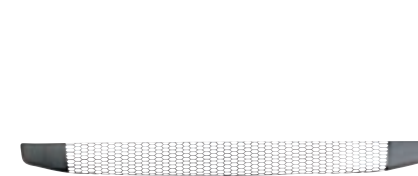

146/852
O.E.M. 1930806

applicabile a | suitable to | verwendbar für:

SCANIA R 2010 CP

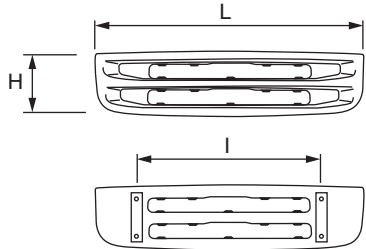

146/255(*)(**)
 senza fori per pedana supplementare
 without holes for additional step panel
 ohne Ausschnitte für zusätzliche
 Fussplatte
 L=1520 H=330 I=950

146/265(*)(*)
 senza fori per pedana supplementare
 without holes for additional step panel
 ohne Ausschnitte für zusätzliche
 Fussplatte
 L=1520 H=330 I=1060

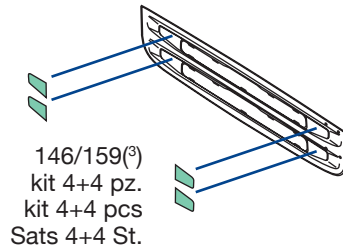
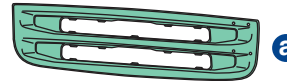
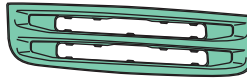

146/159⁽³⁾
 kit 4+4 pz.
 kit 4+4 pcs
 Sats 4+4 St.

146/850(*)(**)
 con fori per pedana supplementare
 with holes for additional step panel
 mit Ausschnitte für zusätzliche
 Fussplatte
 L=1520 H=330 I=950

146/855(*)(**)
 con fori per pedana supplementare
 with holes for additional step panel
 mit Ausschnitte für zusätzliche
 Fussplatte
 L=1520 H=330 I=1060

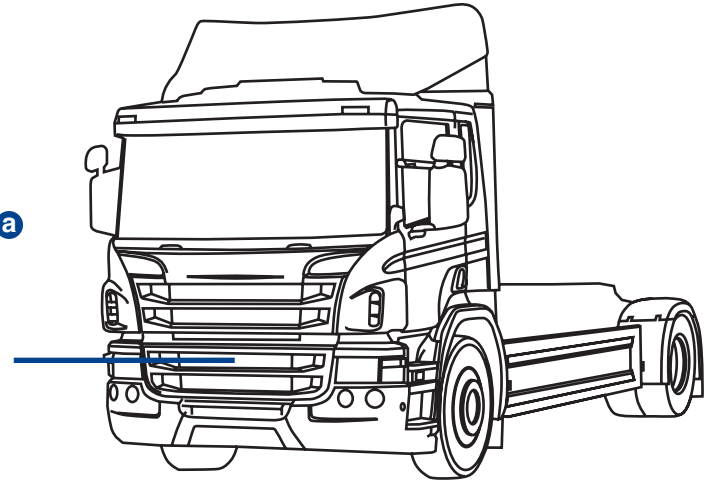

⁽³⁾ Adesivo - Adhesive - selbstklebend

^(**) Per paraurti alto - for high bumper - für hohe Stoßfänger

^(°) Per paraurti basso - for low bumper - für niedrigen Stoßfänger

^(*) Larghezza telaio mm 1020 - chassis width 1020 mm - Chassis: Breite 1020 Millimeter (mm)

^(°) Larghezza telaio mm 1140 - chassis width 1140 mm - Chassis: Breite 1140 Millimeter (mm)



146/159
 O.E.M. 1900636 + 1900634
 1900635 + 1900633



146/255
 O.E.M. 1875843

146/265
 O.E.M. 1885940



146/850
 O.E.M. 1875858

146/855
 O.E.M. 1885949

(a) Variante V8 - fori Ø 8mm | V8 Version - holes Ø 8mm | V8 Version - Ø 8mm Löcher

applicabile a | suitable to | verwendbar für:

SCANIA R 2010 CP

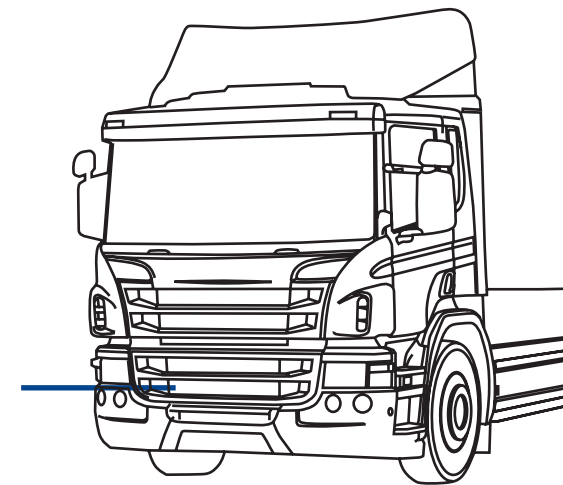
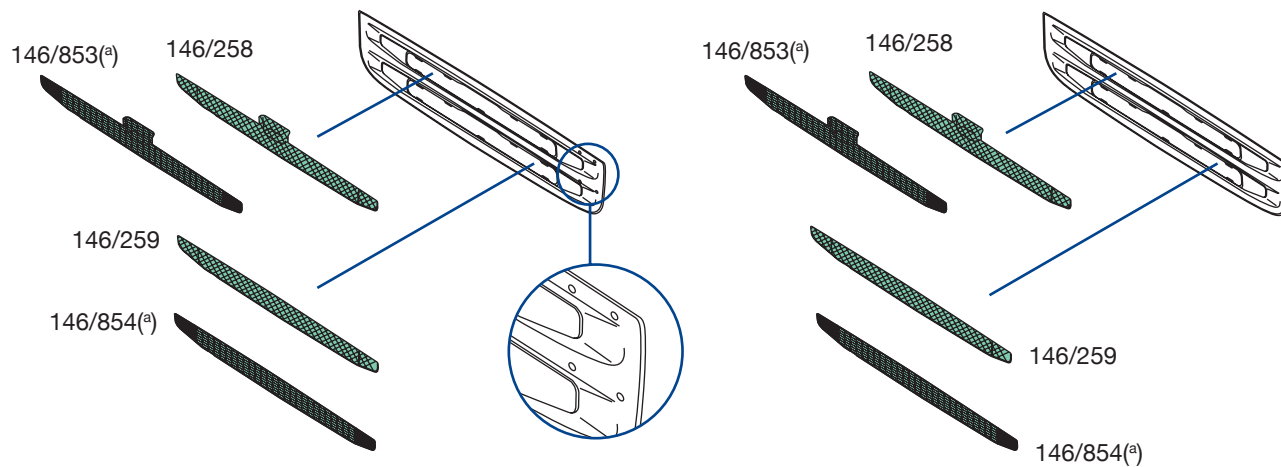

146/258
O.E.M. 1875846

146/259
O.E.M. 1875847

146/853
O.E.M. 1930811

146/854
O.E.M. 1930812

applicabile a | suitable to | verwendbar für:

SCANIA R 2010 CP

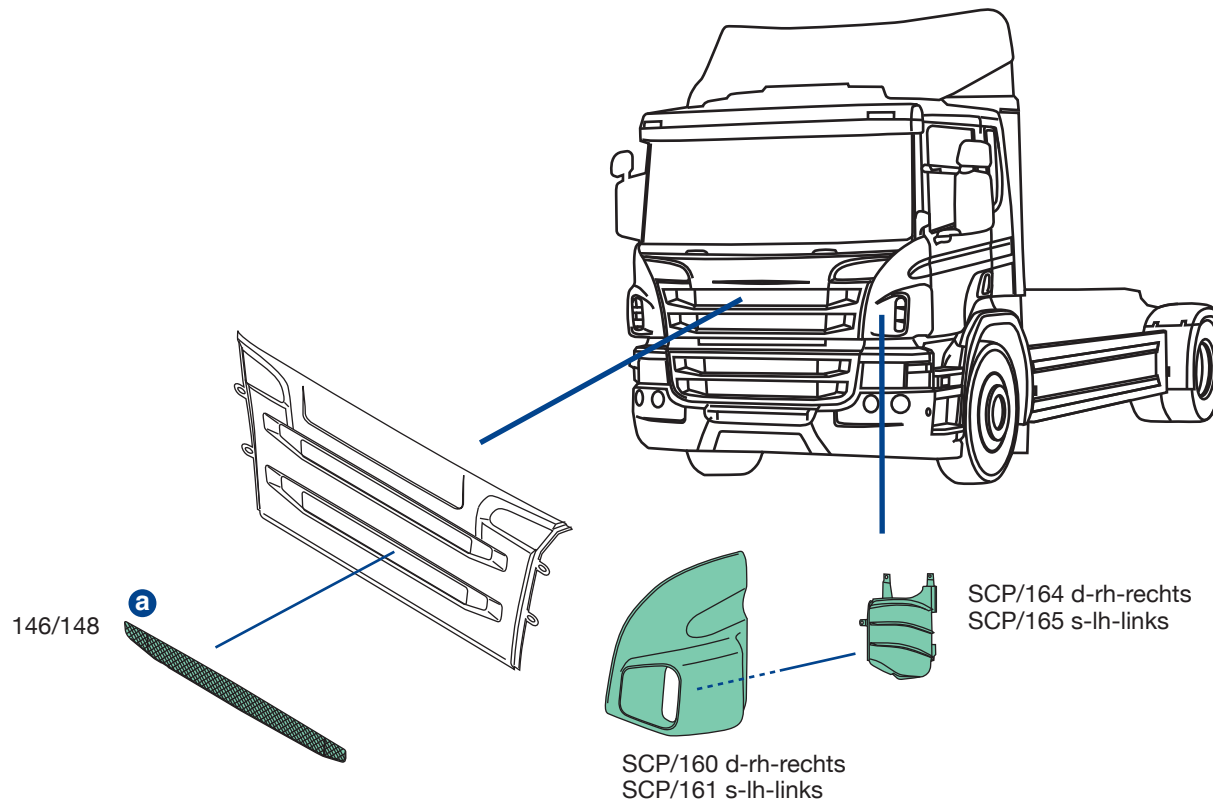

146/148
O.E.M. 1870594

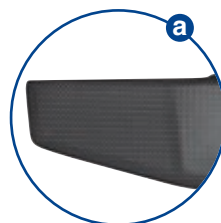

SCP/160
O.E.M. 2165864
SCP/161
O.E.M. 2165863



SCP/164
O.E.M. 1856472
SCP/165
O.E.M. 1856473

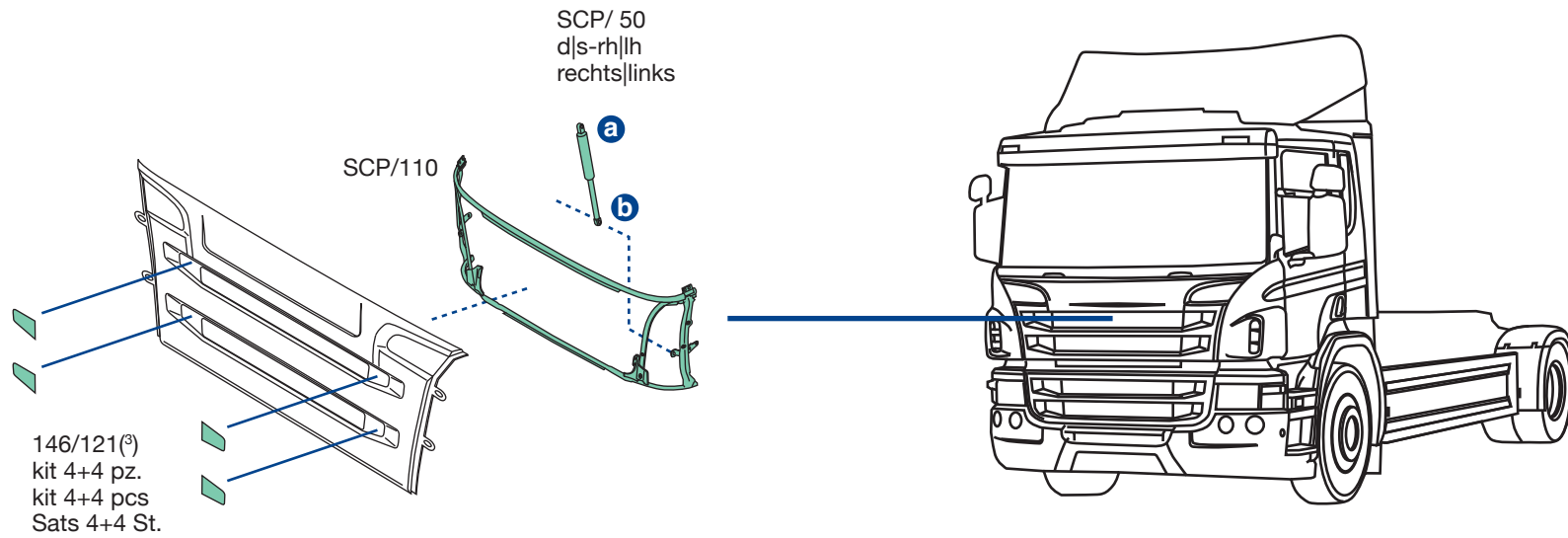

146/121
O.E.M. 2146221 + 2146222



SCP/ 50
O.E.M. 2031866



SCP/110
O.E.M. 2008861

applicabile a | suitable to | verwendbar für:

SCANIA R 2010 CP

SCP/ 2 d-rh-rechts
SCP/ 3 s-lh-links
lastrata, con cerniere
paneled with hinges
rohbautür, mit Scharnier

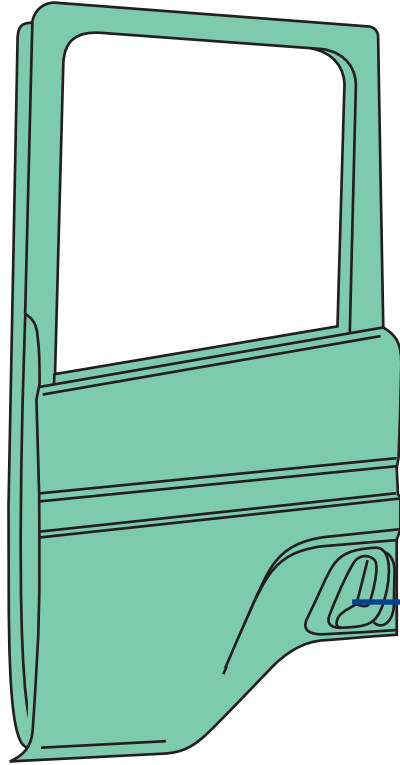

144/194 d-rh-rechts
144/195 s-lh-links

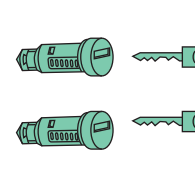
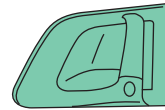

144/196
d|s-rh|lh
rechts|links

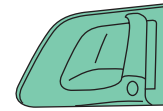

SCR/194 d-rh-rechts
SCR/195 s-lh-links



SCP/ 2
O.E.M. 1476533
SCP/ 3
O.E.M. 1476532



144/194
O.E.M. 2145648
144/195
O.E.M. 2145647



144/196
O.E.M. 1485072



SCR/194
O.E.M. -
SCR/195
O.E.M. -

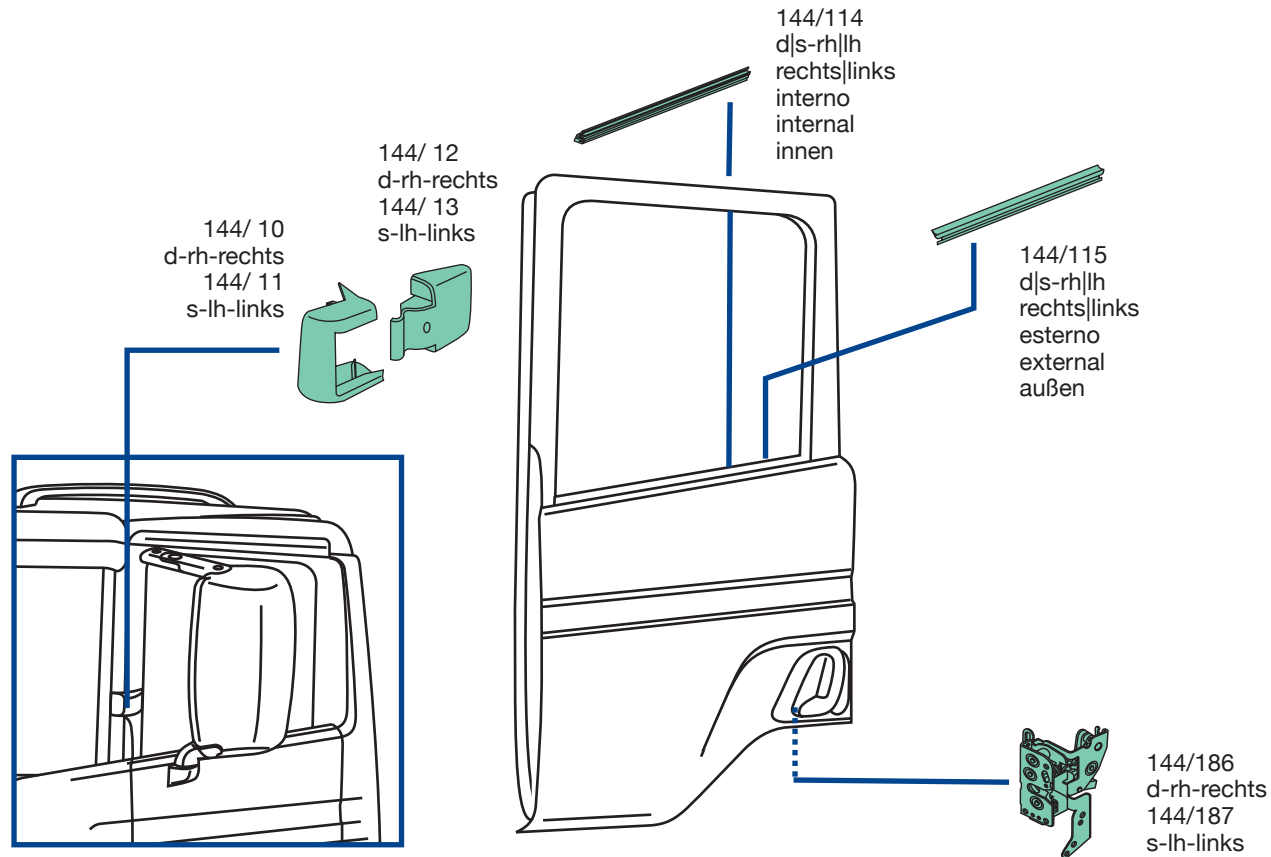

144/10
O.E.M. 1472832
144/11
O.E.M. 1472833



144/12
O.E.M. 1346940
144/13
O.E.M. 1346939



144/114
O.E.M. 1865520

144/115
O.E.M. 1865517



144/186
O.E.M. 1867655
144/187
O.E.M. 1867654

applicabile a | suitable to | verwendbar für:

SCANIA R 2010 CP

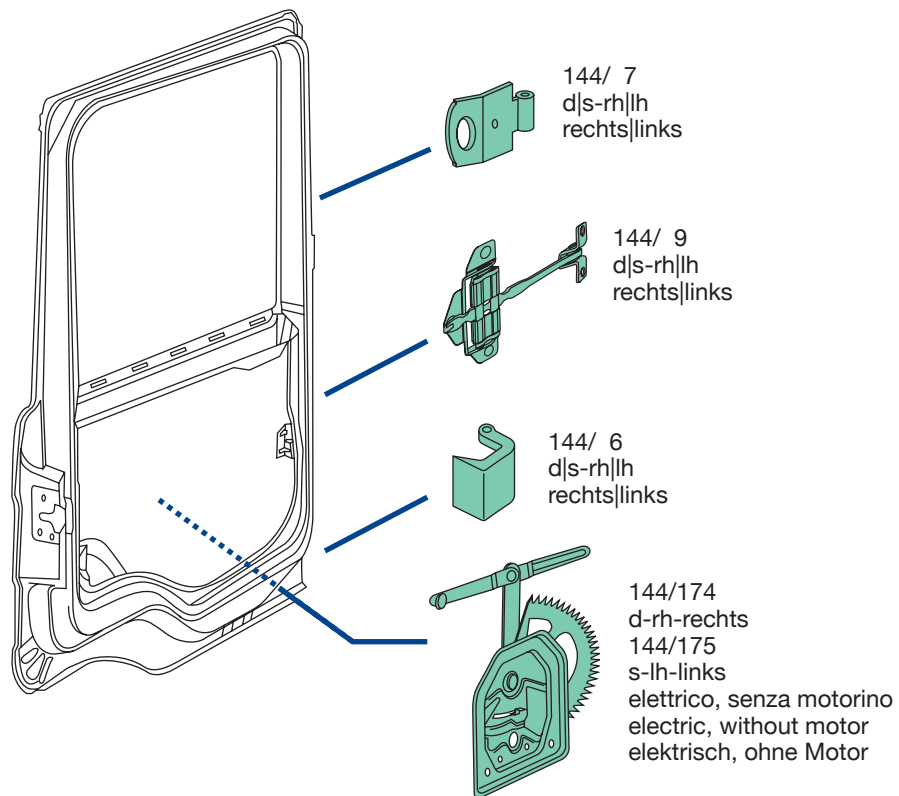

144/ 6
O.E.M. 1426925



144/ 7
O.E.M. 1422292



144/ 9
O.E.M. 1930649



144/174
O.E.M. 2303352
144/175
O.E.M. 2303349

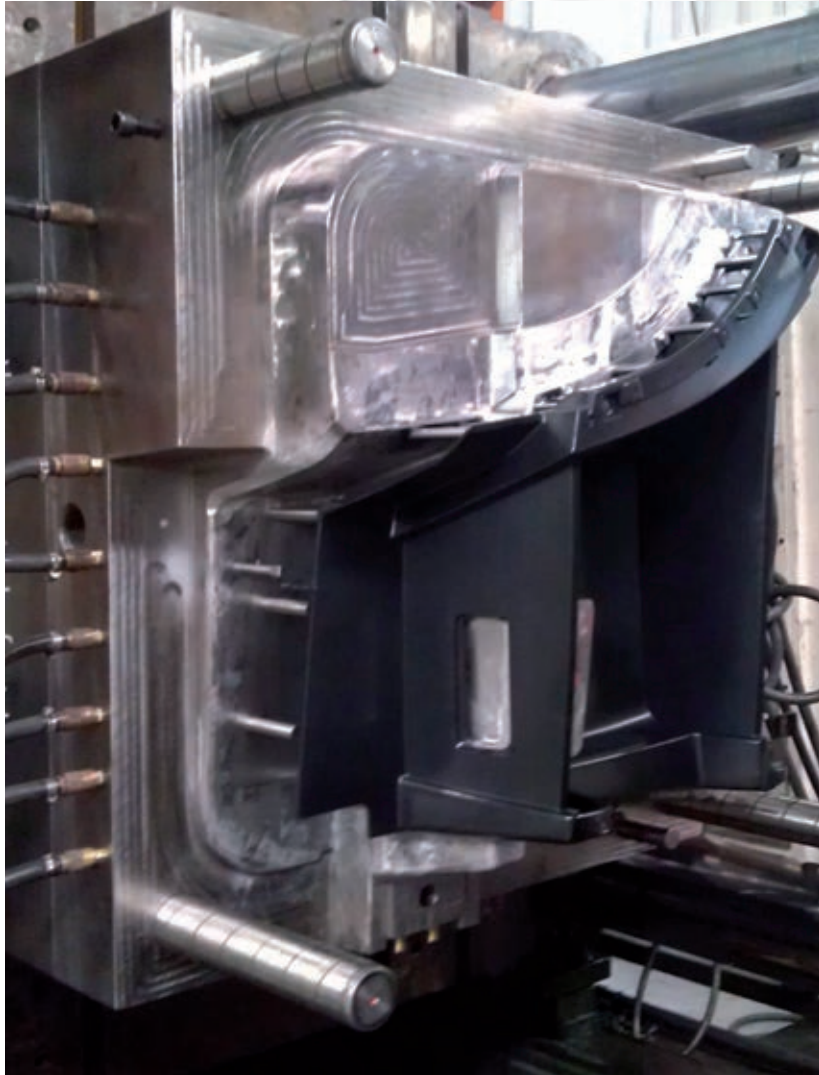

- IT Stampo in acciaio per la produzione pedana destra in polycarbonato
EN Stainless steel mould for the production of right step in polycarbonato
DE Gehärtete Stahlform für die Produktion von Einstiegen aus Polycarbonat

applicabile a | suitable to | verwendbar für:

SCANIA R 2010 CP



144/503



|| E4 024107
200x432 mm



applicabilità:
applicable to:
Verwendbar für

SCANIA SERIE 4 1996→2004
SCANIA SERIE R/P/T 2004→

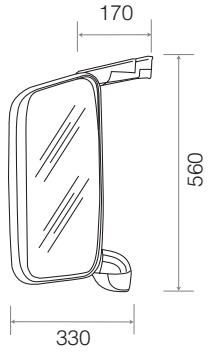

COVIND

||

IV

a

-

-

b

144/501

1765985



E4 024107

200x432 mm



d

-

-

f

144/512

1346380



applicabile a | suitable to | verwendbar für:

SCANIA R 2010 CP



144/505

2425815
(1723518)



E4 024107

200x432 mm

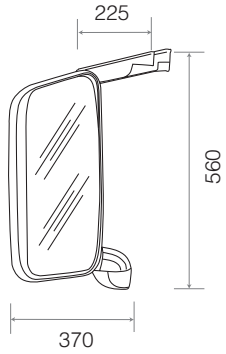

applicabilità:
applicable to:
Verwendbar für

SCANIA SERIE 4 1996→2004
SCANIA SERIE R/P/T 2004→



a

-

-

b

144/501

1765985



E4 024107

200x432 mm



d

-

-

f

144/512

1346380



applicabile a | suitable to | verwendbar für:

SCANIA R 2010 CP



144/506

2425816
(1723519)



II

E4 024107

200x432 mm



IV

E4 024108

160x184 mm

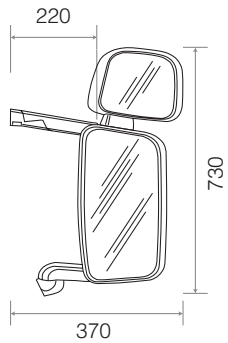

applicabilità:
applicable to:
Verwendbar für

SCANIA SERIE 4 1996→2004
SCANIA SERIE R/P/T 2004→



COVIND

















144/510

IV

1765808



260x348 mm

a	-	-							
b	144/501 II	1765985							E4 024107 200x432 mm
c	144/502 IV	1767265							E4 024108 160x184 mm
d	-	-							
e	-	-							
f	144/512	1346380							

applicabile a | suitable to | verwendbar für:

SCANIA R 2010 CP



144/507



II (E4) 024107
200x432 mm



IV (E4) 024108
184x160 mm

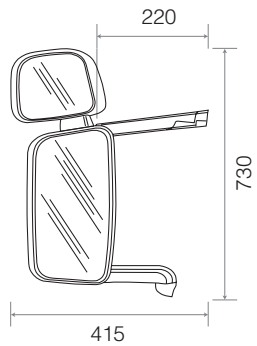
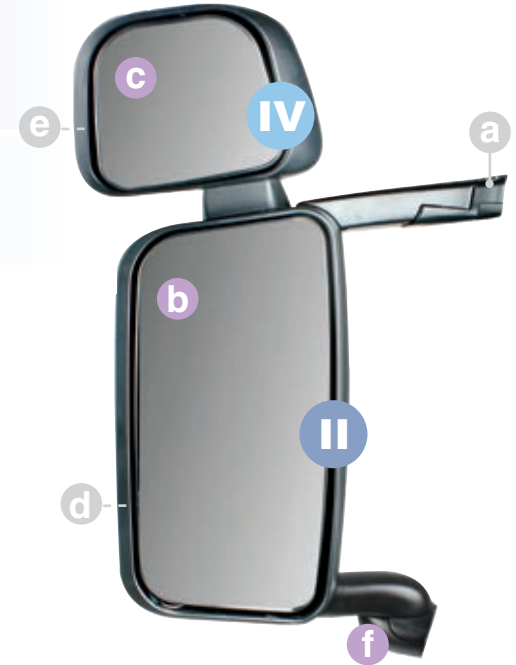

applicabilità:
applicable to:
Verwendbar für

SCANIA SERIE 4 1996→2004
SCANIA SERIE R/P/T 2004→

COVIND

144/511
IV

1765809



260x348 mm

a	-	-							
b	144/501 II	1765985							E4 024107 200x432 mm
c	144/502 IV	1767265							E4 024108 184x160 mm
d	-	-							
e	-	-							
f	144/512	1346380							

applicabile a | suitable to | verwendbar für:

SCANIA R 2010 CP



144/508



II (E4) 024107
200x432 mm



IV (E4) 024108
184x160 mm

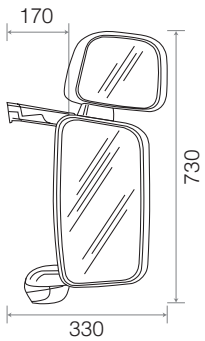

applicabilità:
applicable to:
Verwendbar für

SCANIA SERIE 4 1996→2004
SCANIA SERIE R/P/T 2004→

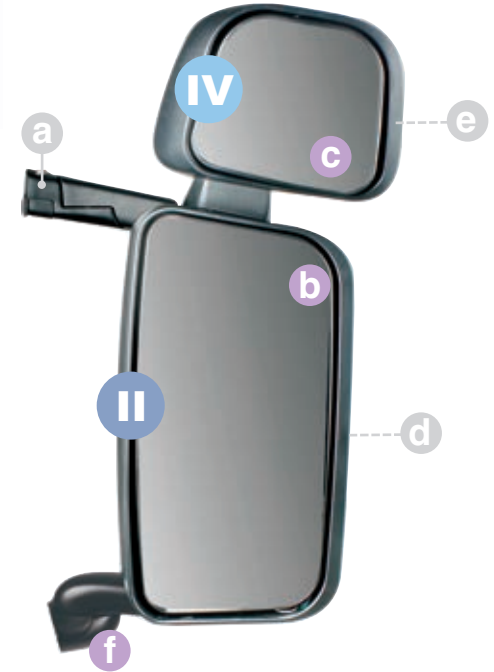

















COVIND

144/510

1765808



260x348 mm

a	-	-							
b	144/501 II	1765985							E4 024107 200x432 mm
c	144/502 IV	1767265							E4 024108 184x160 mm
d	-	-							
e	-	-							
f	144/512	1346380							

applicabile a | suitable to | verwendbar für:

SCANIA R 2010 CP



144/509



II

E4 024107

200x432 mm



IV

E4 024108

184x160 mm



applicabilità:
applicable to:
Verwendbar für

SCANIA SERIE 4 1996→2004
SCANIA SERIE R/P/T 2004→

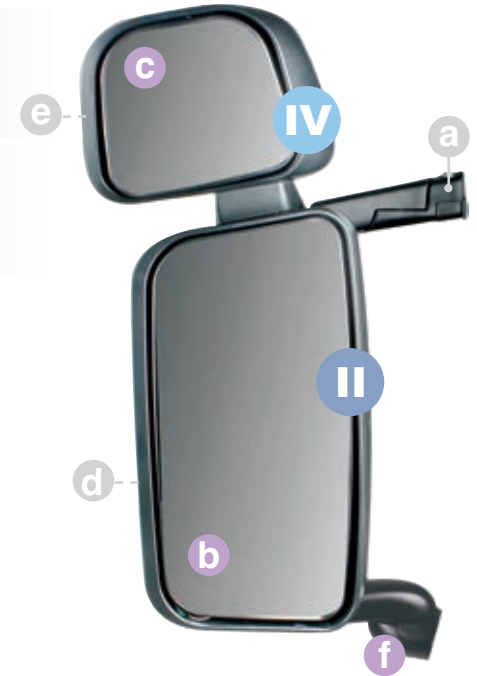
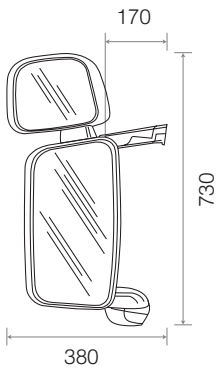

COVIND

















144/511

1765809



260x348 mm

IV

a	-	-		    	E4 024107	200x432 mm	
b	144/501	1765985	II				
c	144/502	1767265	IV		    	E4 024108	184x160 mm
d	-	-					
e	-	-					
f	144/512	1346380			   		

applicabile a | suitable to | verwendbar für:

SCANIA R 2010 CP

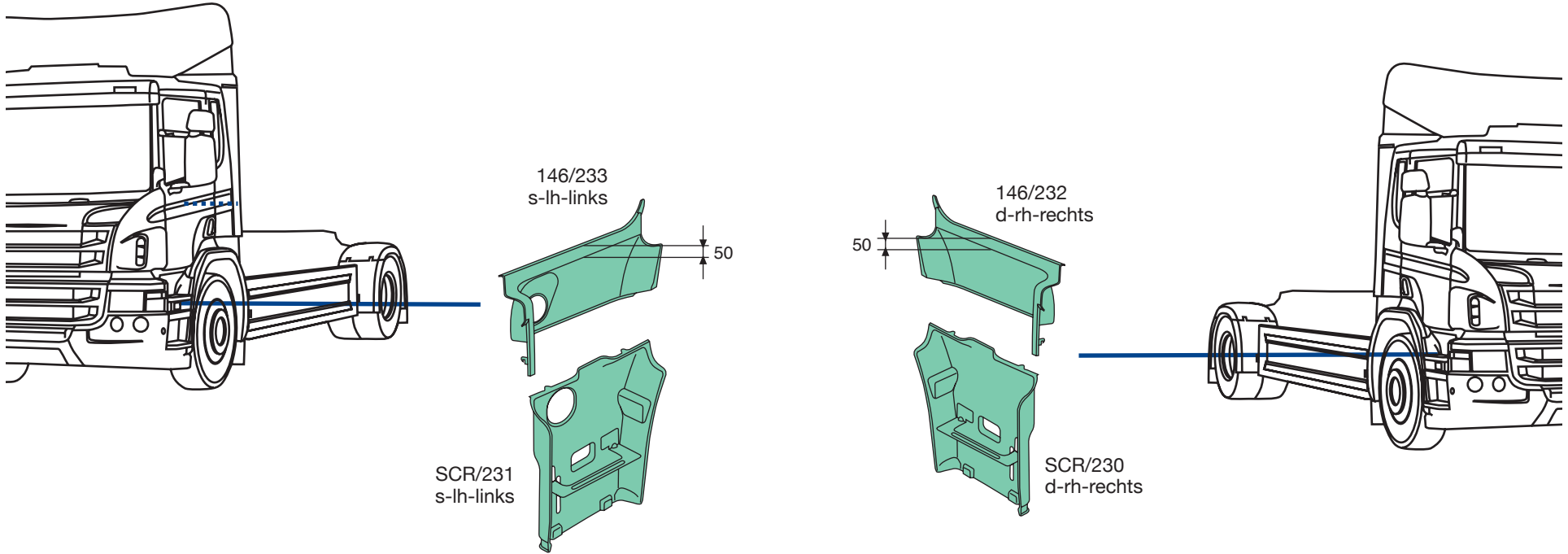

146/232
O.E.M. 1805342



146/233
O.E.M. 1805341



SCR/230
O.E.M. 1854228



SCR/231
O.E.M. 1854227

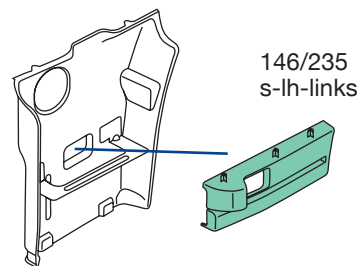
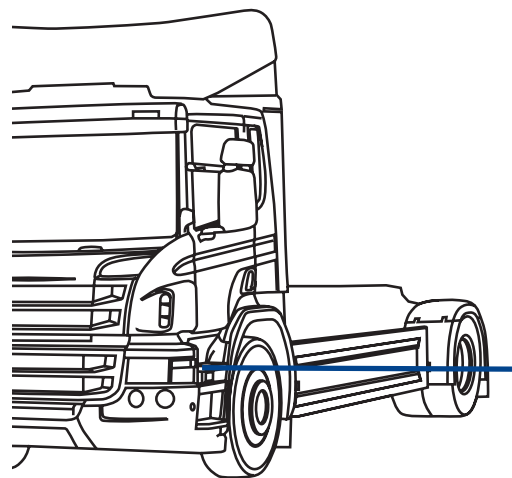

146/235
s-lh-links

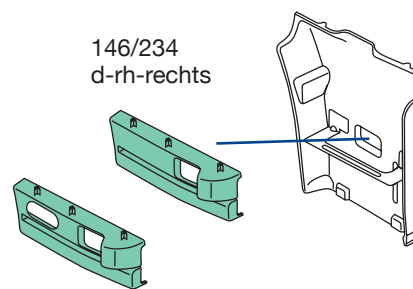

146/234
d-rh-rechts

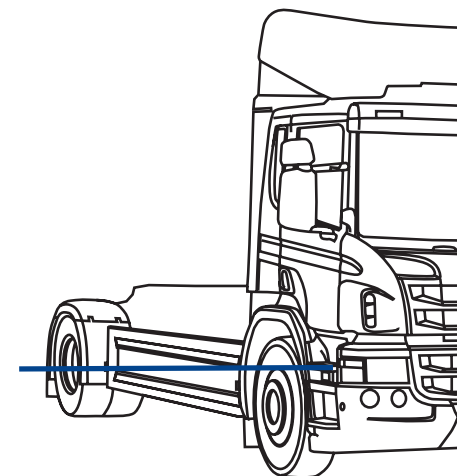

146/236
d-rh-rechts



146/234
O.E.M. 1779121



146/235
O.E.M. 1779120



146/236
O.E.M. 1787896

applicabile a | suitable to | verwendbar für:

SCANIA R 2010 CP

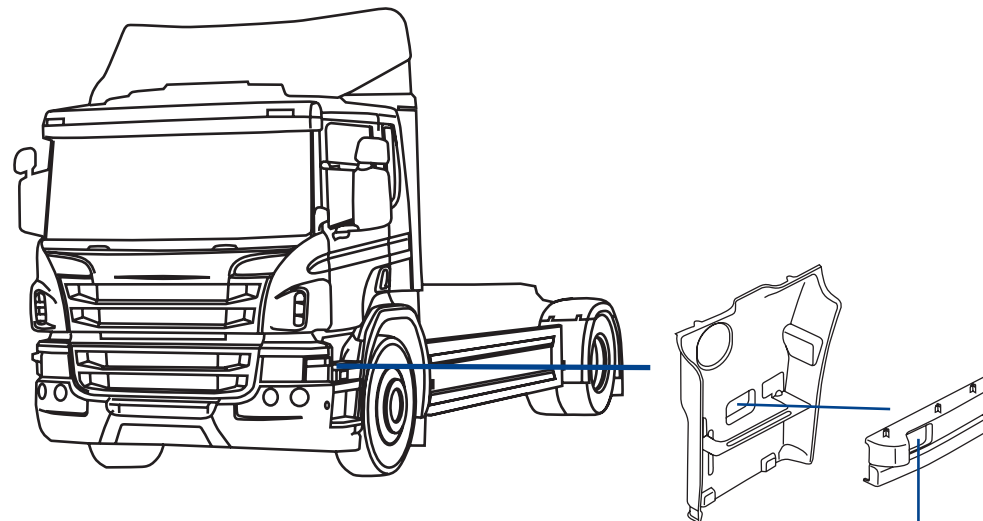

SCR/505
d|s-rh|lh-rechts|links
segnalatore laterale (a lampadina)
side marker (with bulb)
Seiten markierung (mit Glühbirne)

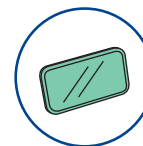

SCR/506
d|s-rh|lh-rechts|links
segnalatore laterale (3 led)
side marker (3 led)
Seiten markierung (3 led)

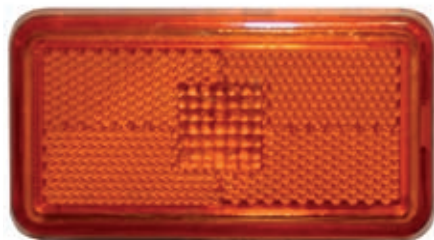

SCR/505
O.E.M. 2052117



SCR/506
O.E.M. 2080828

SCANIA R 2010 CP

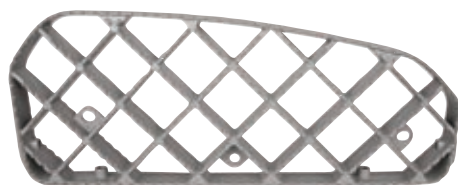
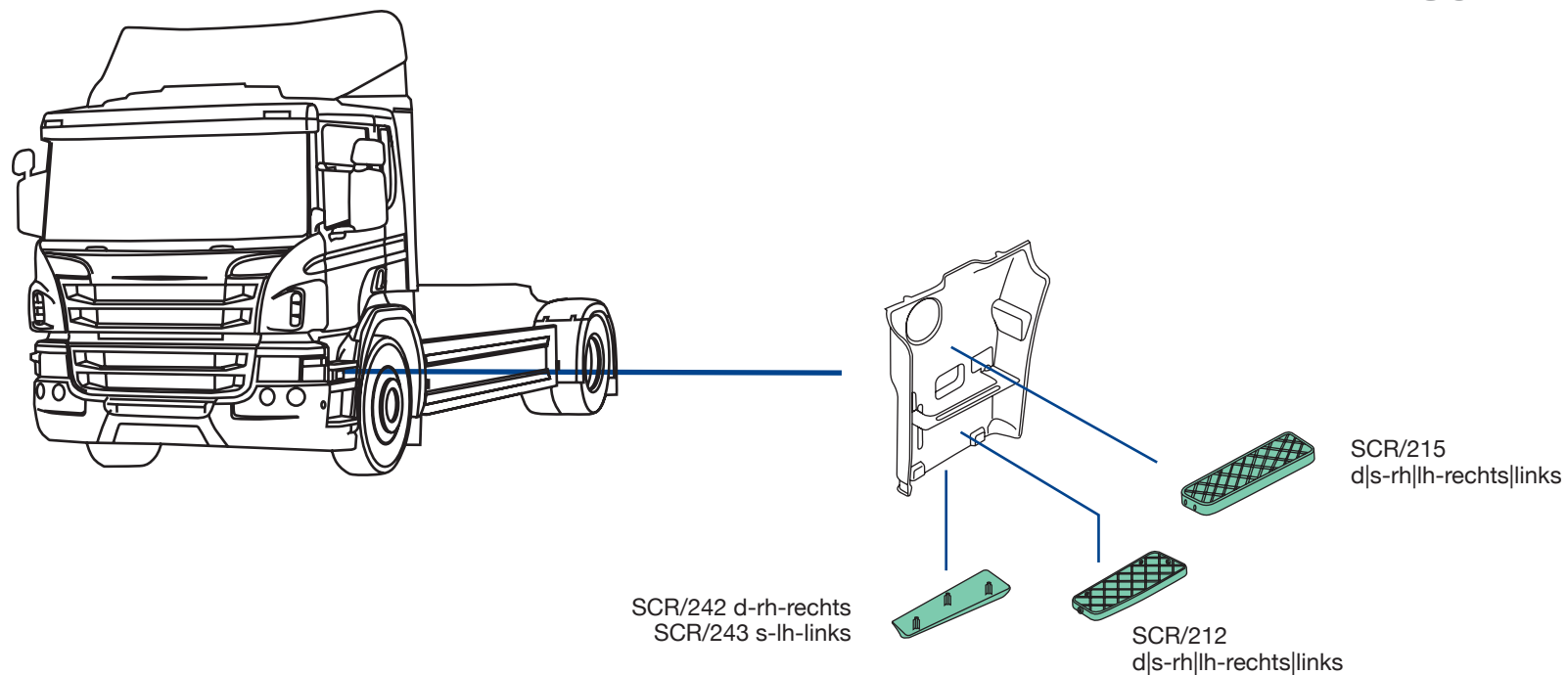

SCR/212
O.E.M. 1535052

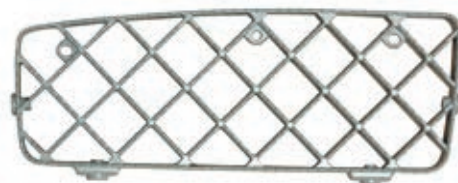

SCR/215
O.E.M. 1805447



SCR/242
O.E.M. 1512424
SCR/243
O.E.M. 1512423

applicabile a | suitable to | verwendbar für:

SCANIA R 2010 CP

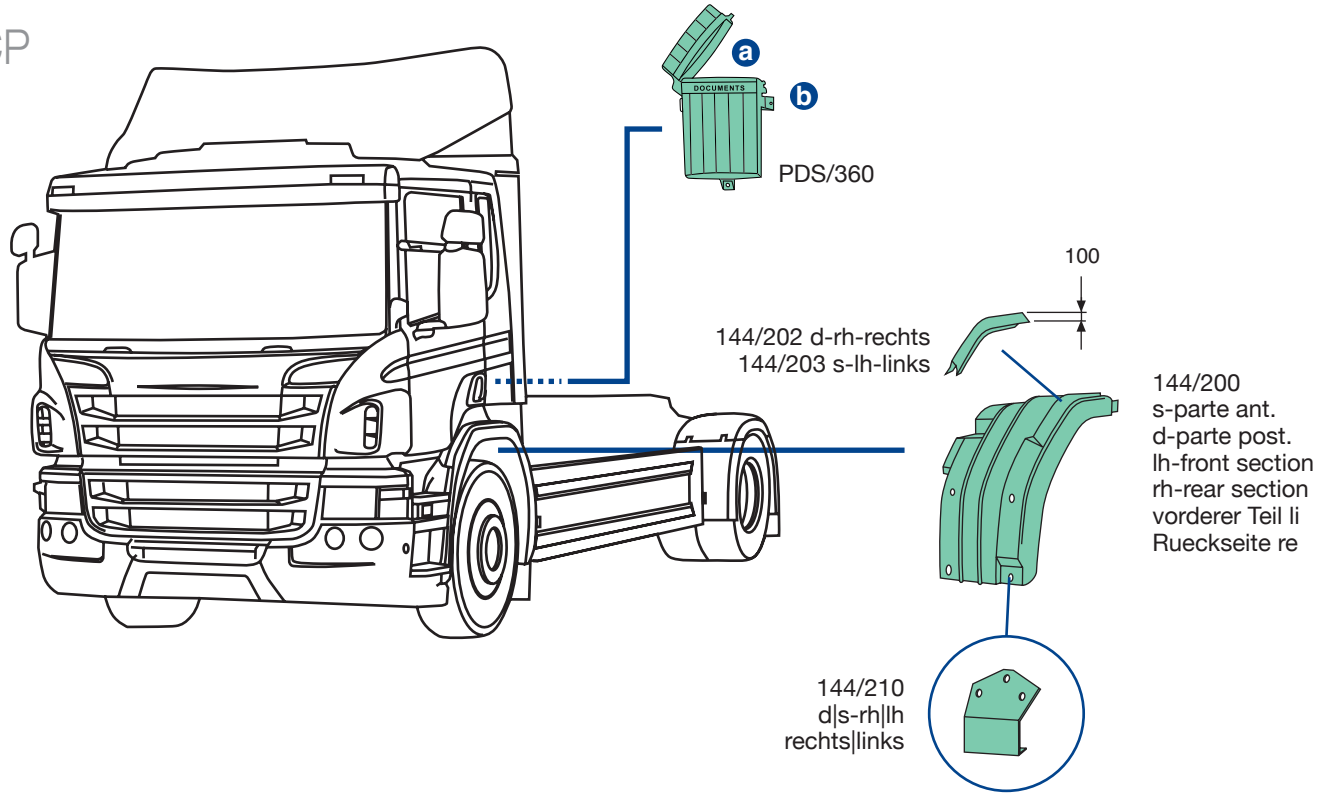

PDS/360

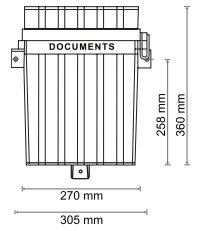

144/200
O.E.M. 1485485



144/202
O.E.M. 1517650
144/203
O.E.M. 1517649



144/210
O.E.M. 1398873



PDS/360
O.E.M. -

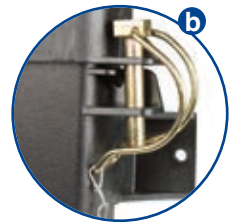

SCANIA R 2010 CP

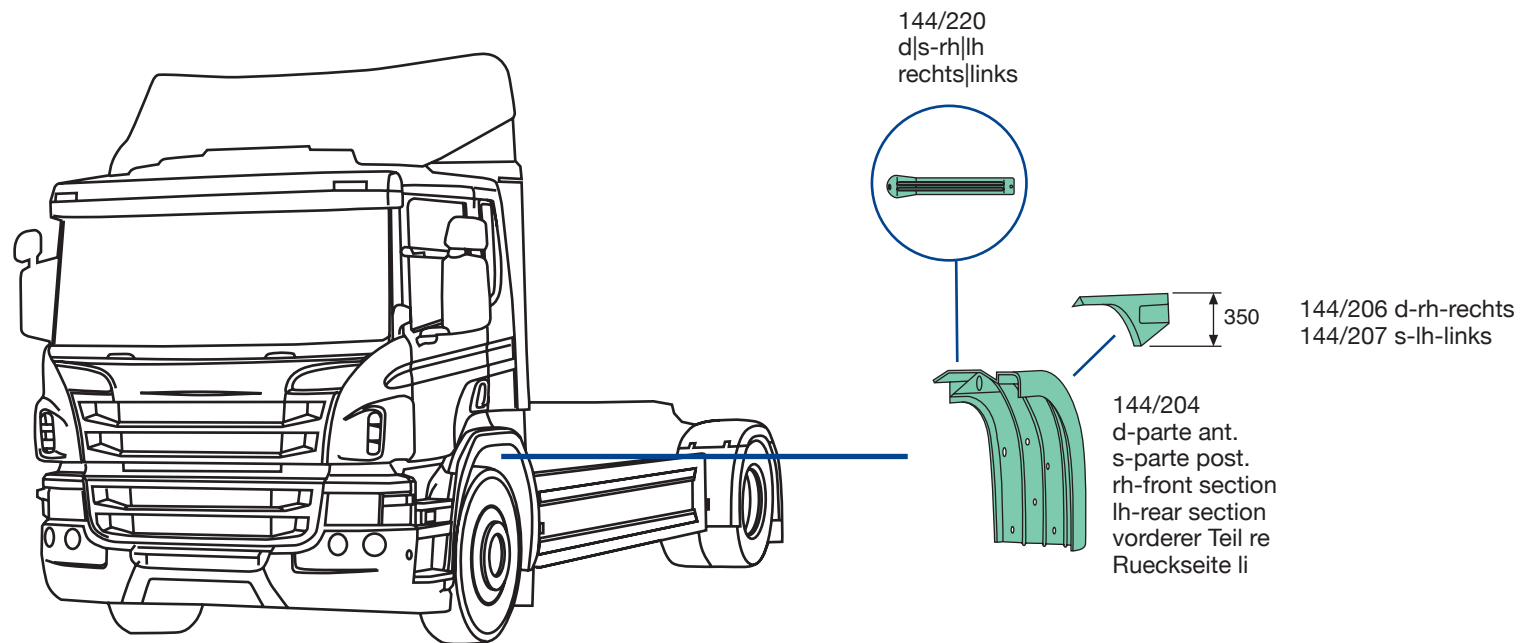

144/204
O.E.M. 1485486



144/206
O.E.M. 1364666
144/207
O.E.M. 1364665



144/220
O.E.M. 1479924

applicabile a | suitable to | verwendbar für:

SCANIA R 2010 CP

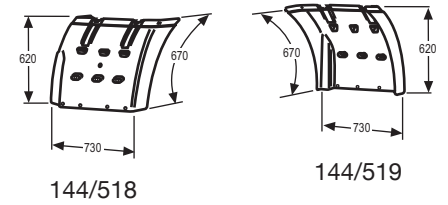
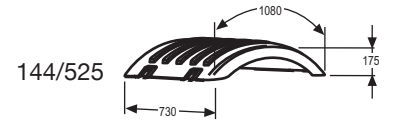
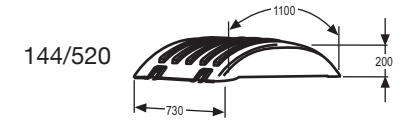
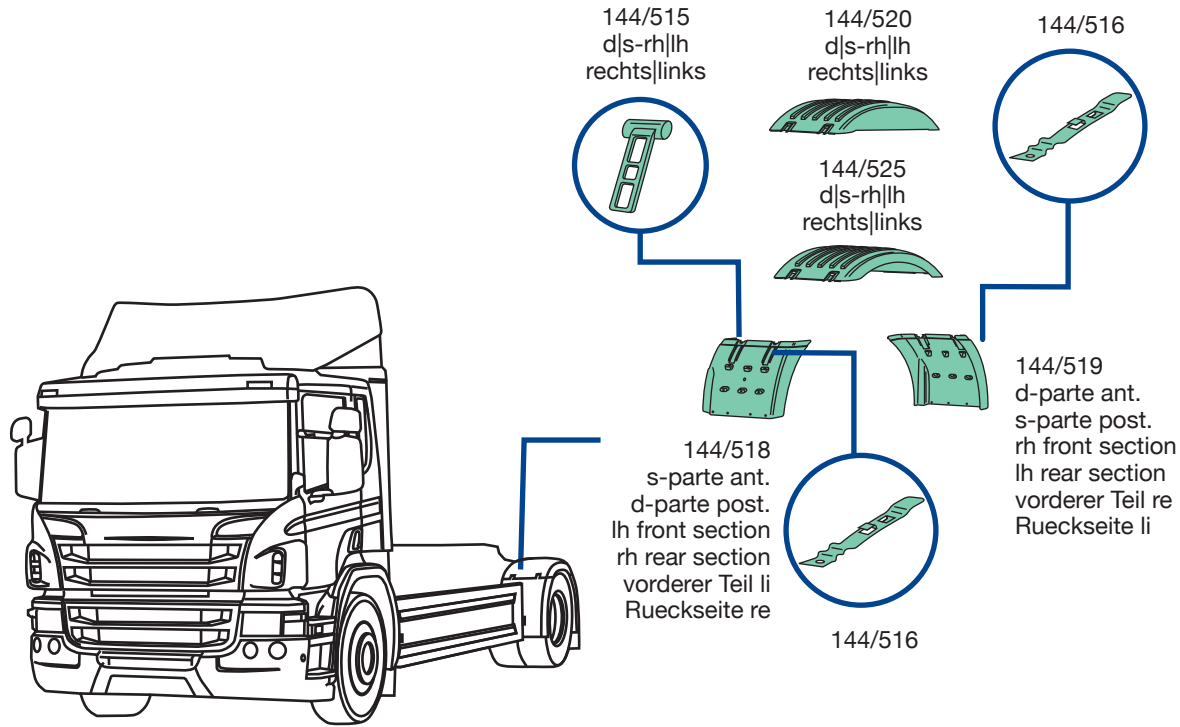

144/515
O.E.M. 1383858



144/516
O.E.M. 2056867

144/520
 O.E.M. 1357601
 d|s-rh|lh-rechts|links
 grigio, circolare, senza cinghietti
 grey, circular, without stretchers
 grau, halbrund, ohne Spanngummi



144/519
 O.E.M. 1357599
 d|s-rh|lh-rechts|links
 grigio, senza anti-spray
 grey, without anti-spray
 grau, ohne Spritzschutz



144/518
 O.E.M. 1357600
 d|s-rh|lh-rechts|links
 grigio
 grey
 grau

144/525
 O.E.M. 1395276
 d|s-rh|lh-rechts|links
 grigio, semipiatta, senza cinghietti
 grey, semi-flat, without stretchers
 grau, halbflach, ohne Spanngummi



144/518

applicabile a | suitable to | verwendbar für:

SCANIA R 2010 CP

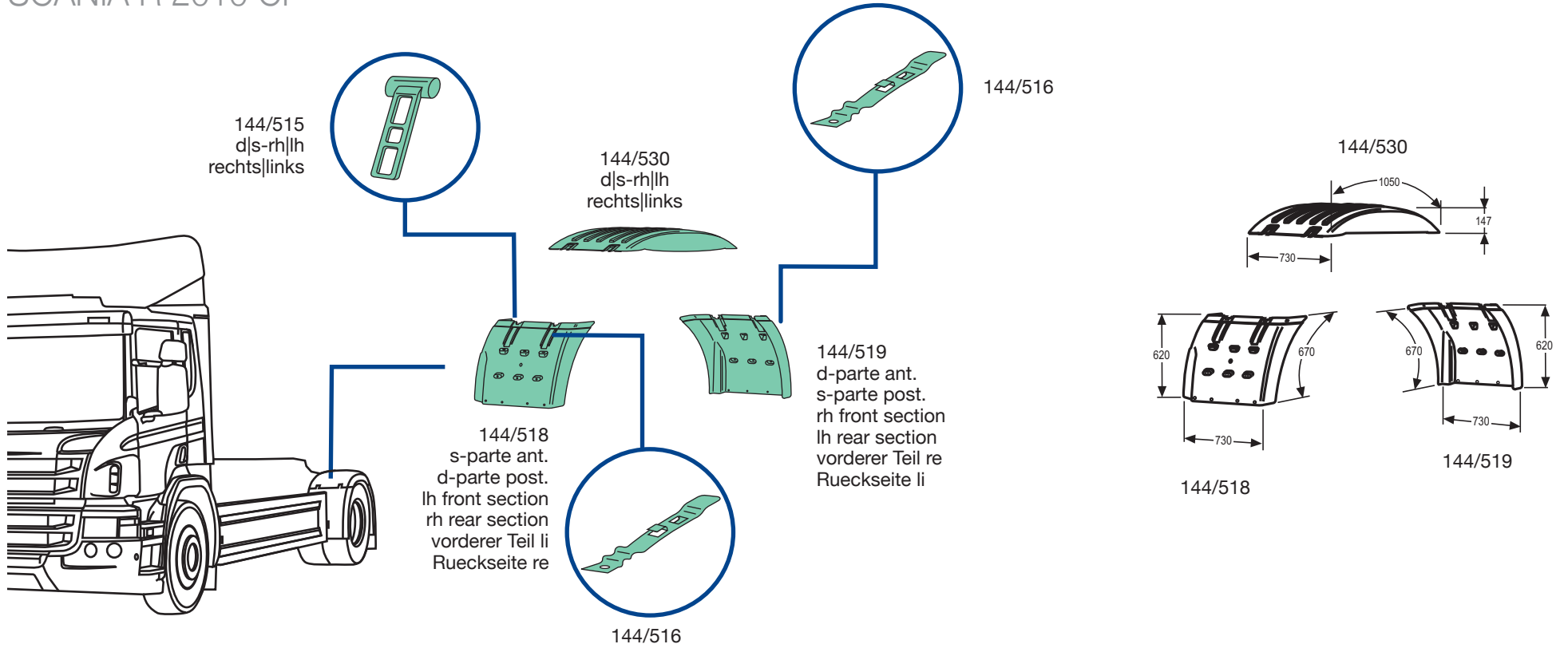

144/515
O.E.M. 1383858



144/516
O.E.M. 2056867

144/530
 O.E.M. 1357602
 d|s-rh||h-rechts|links
 grigio, piatta, senza cinghietti
 grey, flat, without stretchers
 grau, flach, ohne Spanngummi

144/519
 O.E.M. 1357599
 d|s-rh||h-rechts|links
 grigio, senza anti-spray
 grey, without anti-spray
 grau, ohne Spritzschutz



144/518
 O.E.M. 1357600
 d|s-rh||h-rechts|links
 grigio
 grey
 grau



applicabile a | suitable to | verwendbar für:

SCANIA R 2010 CP

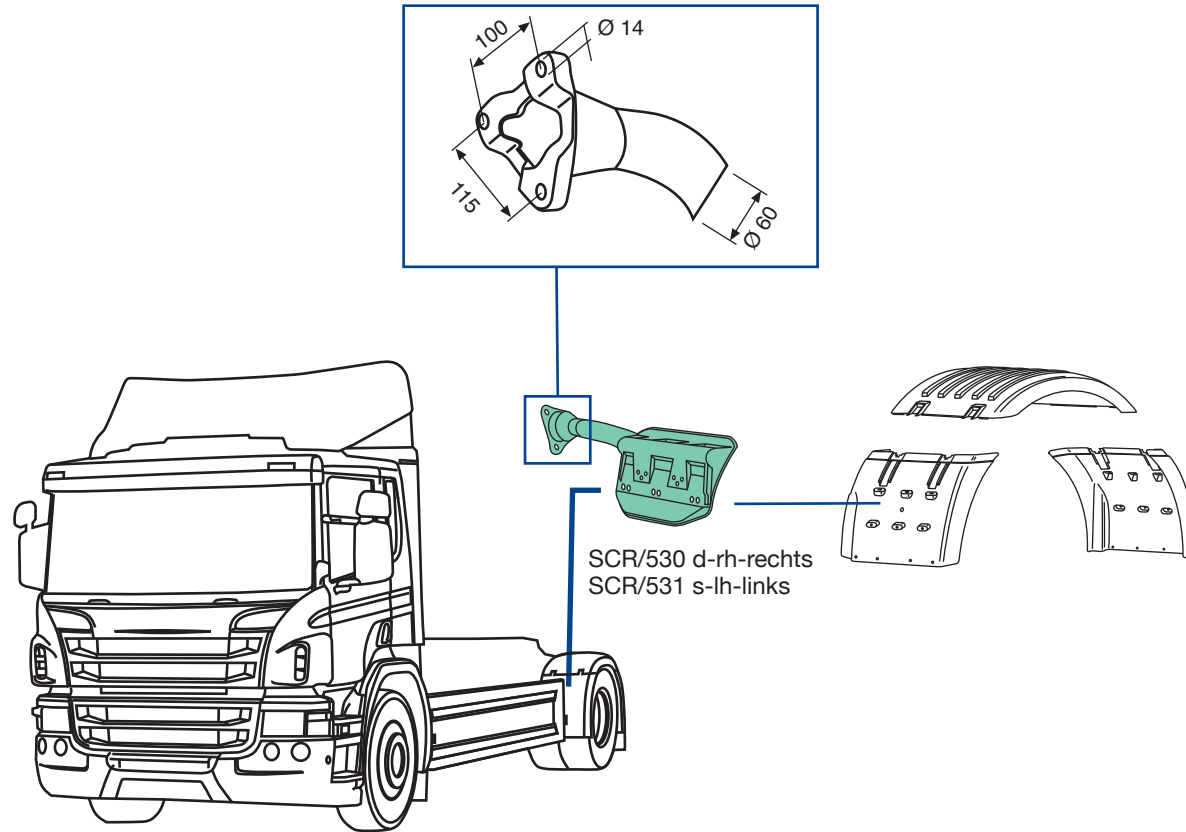



SCR/530
O.E.M. 2054582
anteriore destro
front right
vorne rechts

SCR/531
O.E.M. 2054581
anteriore sinistro
front left
vorne links

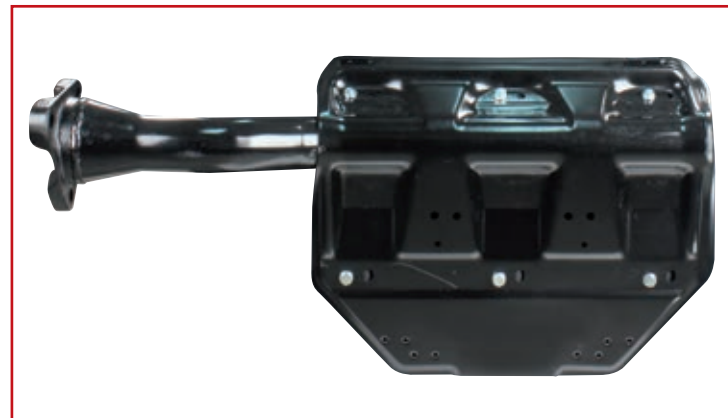
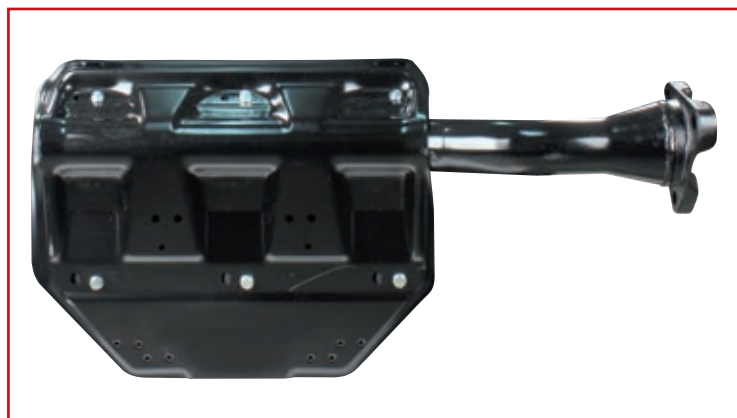

applicabile a | suitable to | verwendbar für:

SCANIA R 2010 CP

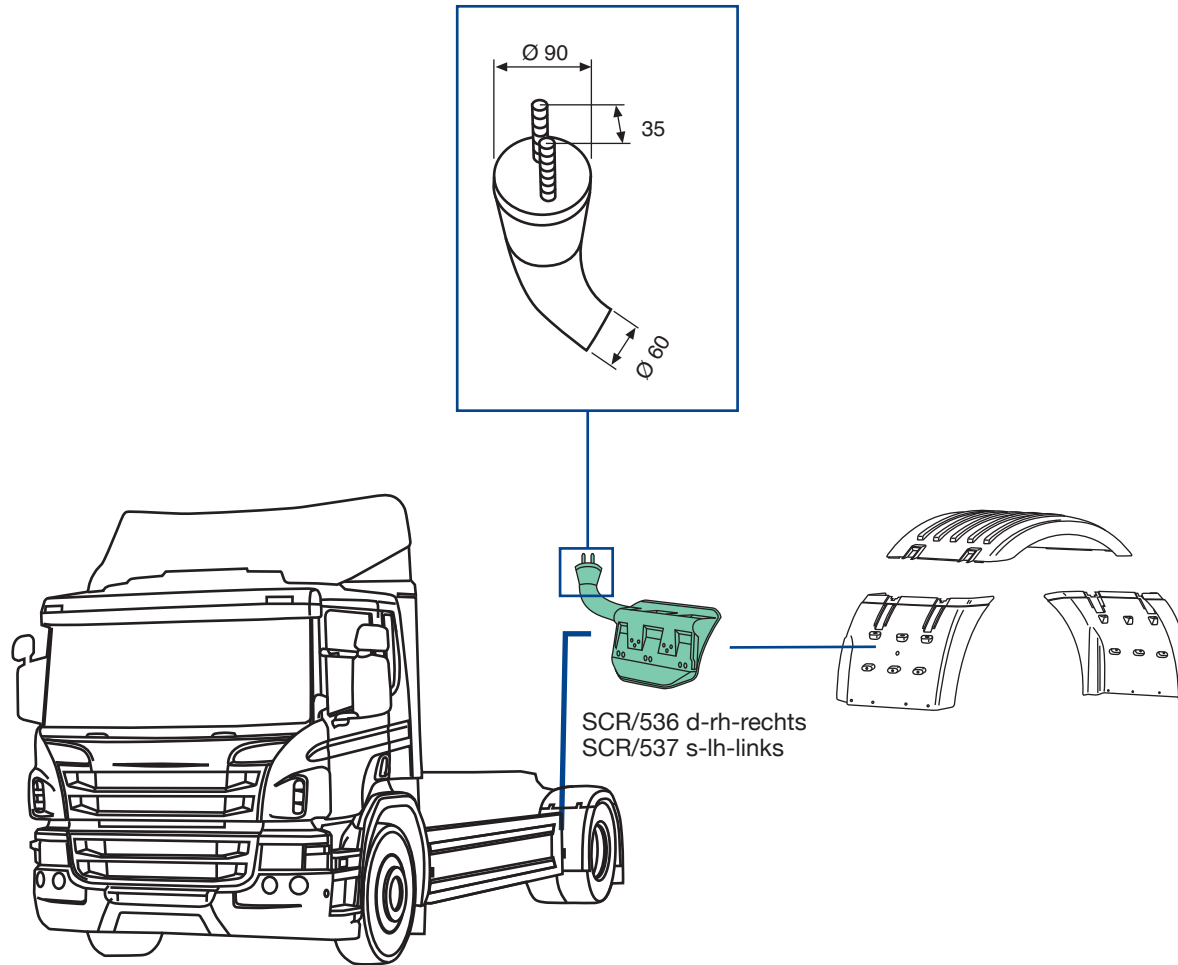



SCR/536
O.E.M. 1457920
anteriore destro
front right
vorne rechts

SCR/537
O.E.M. 1457919
anteriore sinistro
front left
vorne links

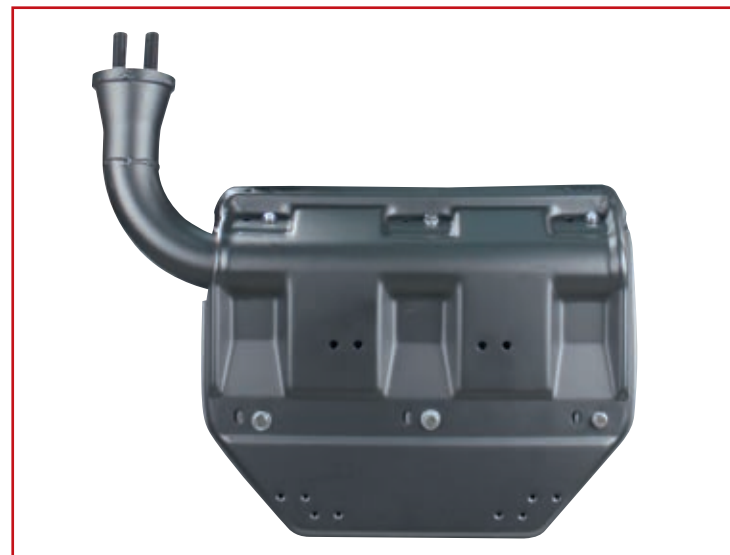

applicabile a | suitable to | verwendbar für:

SCANIA R 2010 CP

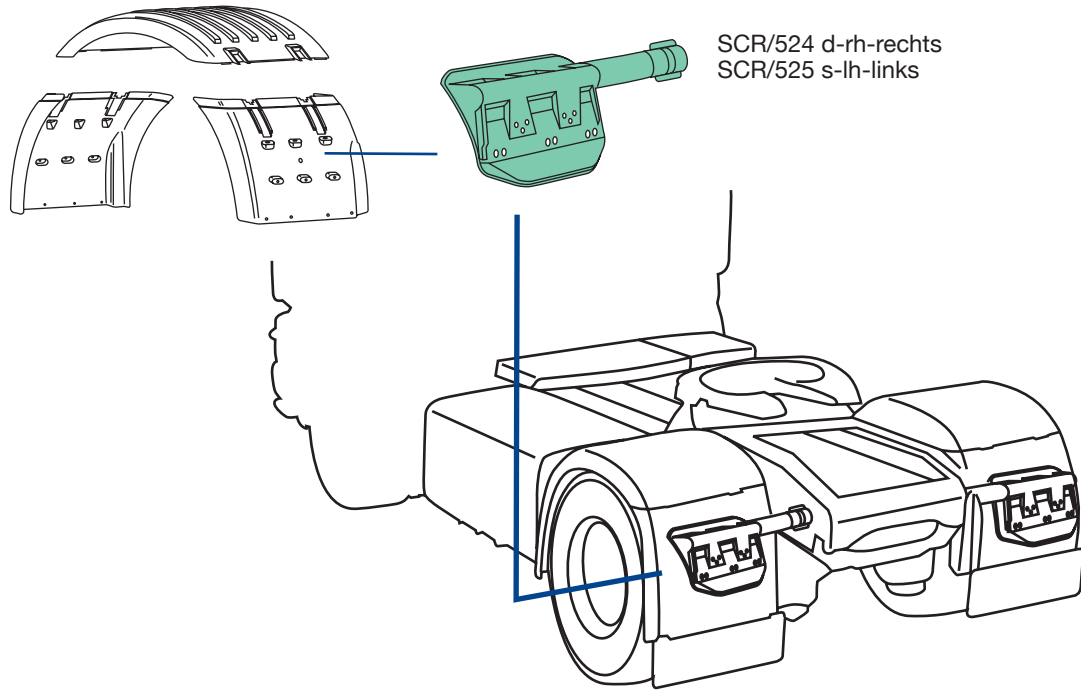



SCR/525
O.E.M. 2054589
posteriore sinistro
rear left
hinten links

SCR/524
O.E.M. 2054590
posteriore destro
rear right
hinten rechts



applicabile a | suitable to | verwendbar für:

SCANIA R 2010 CP

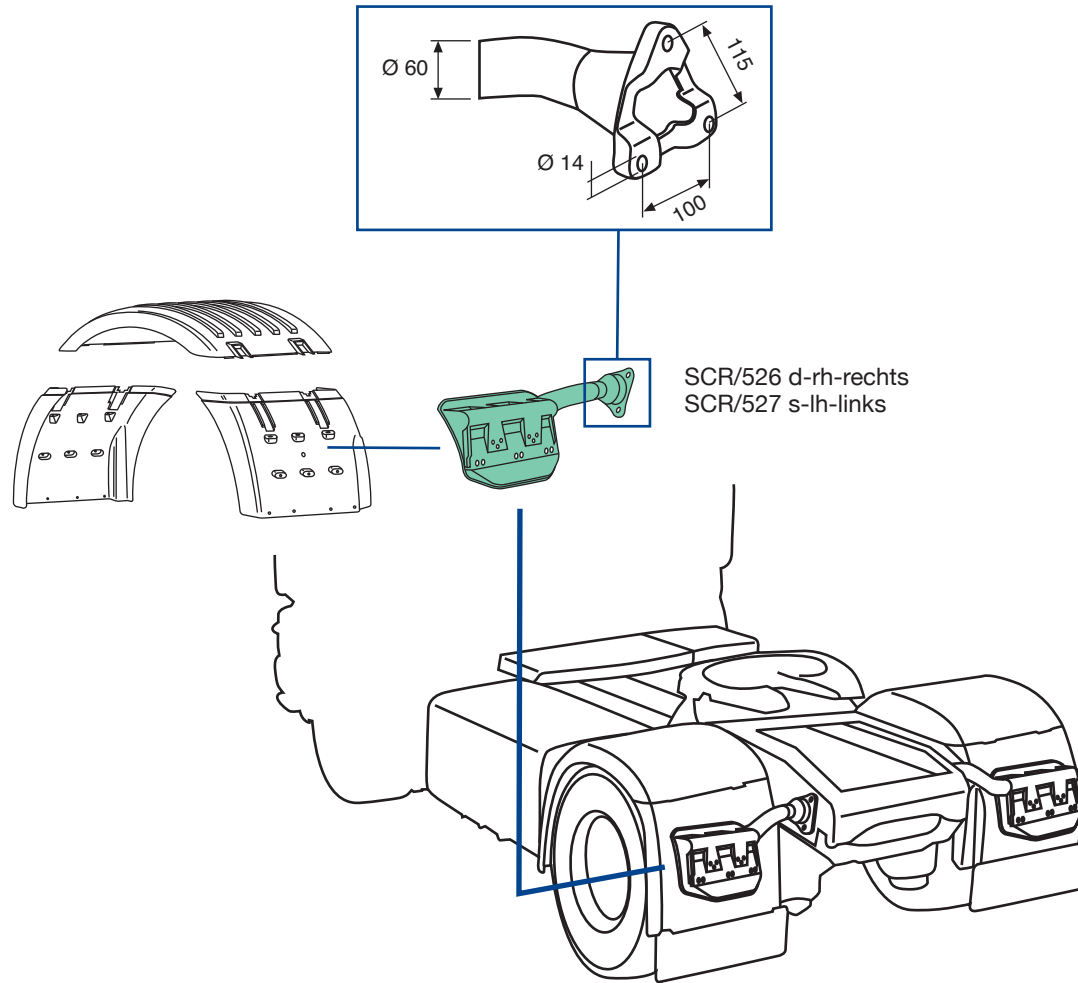



SCR/527
O.E.M. 2054579
posteriore sinistro
rear left
hinten links

SCR/526
O.E.M. 2054580
posteriore destro
rear right
hinten rechts



applicabile a | suitable to | verwendbar für:

SCANIA R 2010 CP

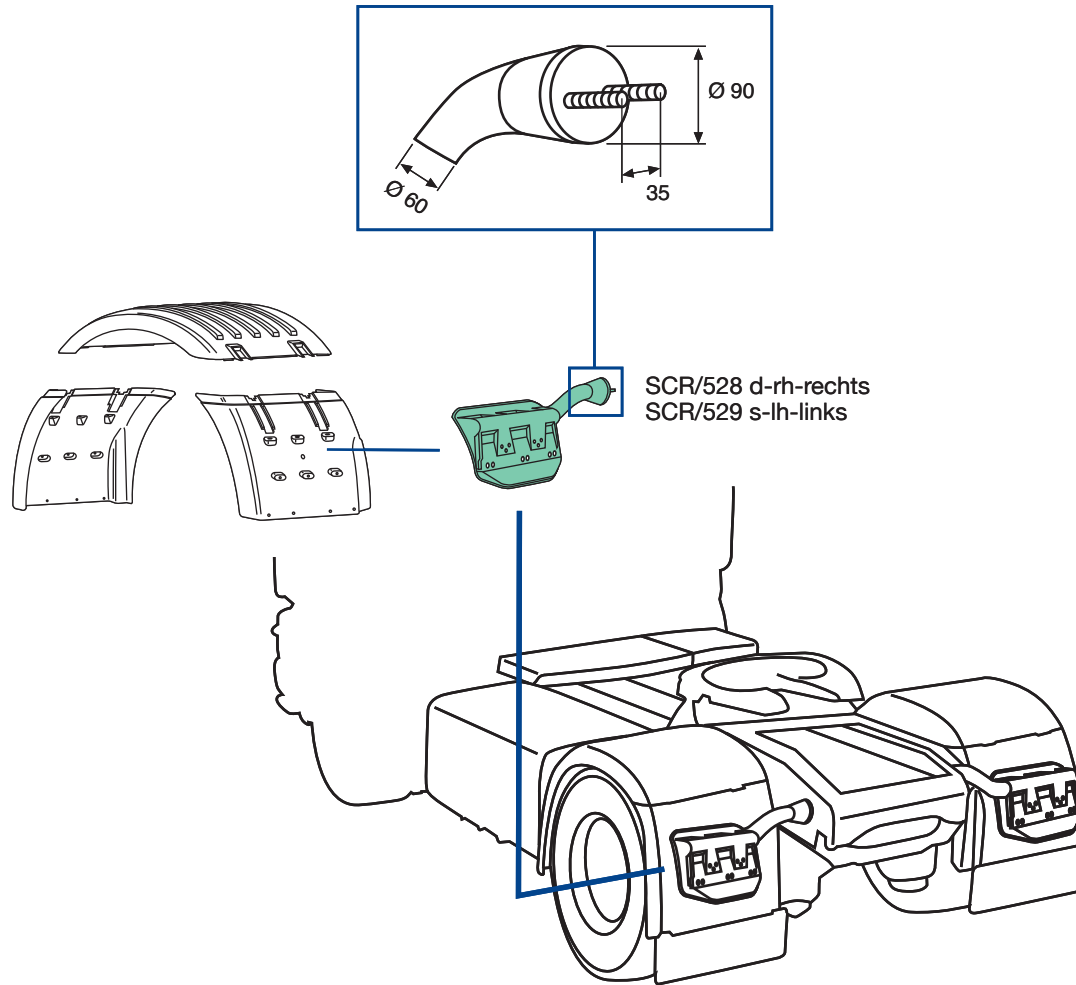



SCR/529
O.E.M. 2054603
posteriore sinistro
rear left
hinten links

SCR/528
O.E.M. 2054604
posteriore destro
rear right
hinten rechts



applicabile a | suitable to | verwendbar für:

SCANIA R 2010 CP

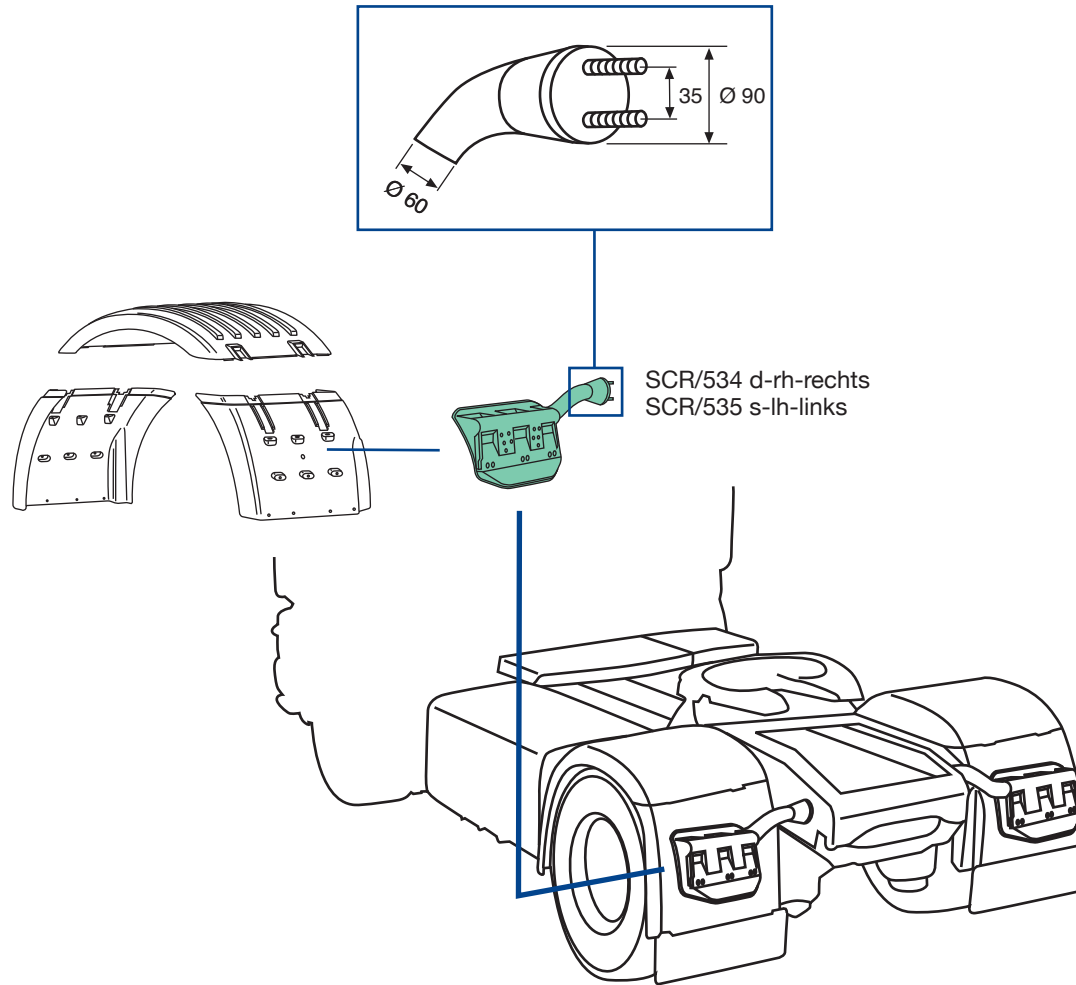



SCR/535
O.E.M. 2054601
posteriore sinistro
rear left
hinten links

SCR/534
O.E.M. 2054602
posteriore destro
rear right
hinten rechts



applicabile a | suitable to | verwendbar für:

SCANIA R 2010 CP

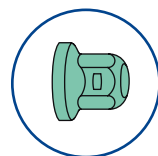
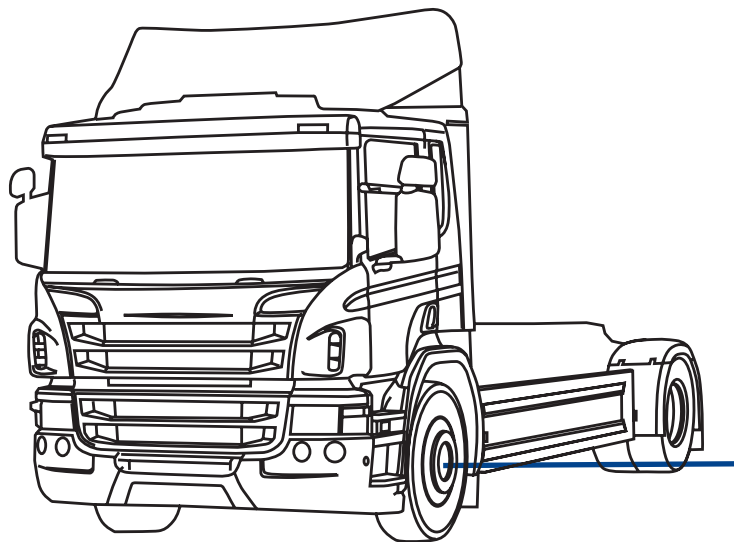

930/033

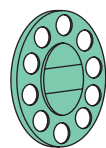

930/001
d-rh-rechts
930/002
s-lh-links



930/200
d|s-rh|lh
rechts|links



930/100 d-rh-rechts
930/101 s-lh-links



930/033
O.E.M. -



930/001
O.E.M. -
930/002
O.E.M. -



930/100
O.E.M. -
930/101
O.E.M. -



930/200
O.E.M. -

930/033 - Tappo copri Bullone - Bolt cover - Radmutterkappen

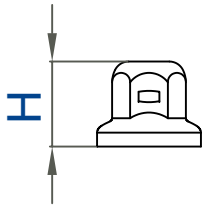

H	45 mm
Per bulloni \varnothing - bolt \varnothing	33 mm
Schlüsselweite \varnothing	
Colore	cromato-chrome-verchromt
Colours-Farbe	
Materiale-Material	acciaio inox-stainless steel Edelstahl
Kg	0,025

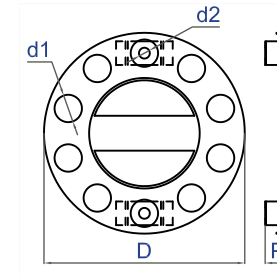

930/001 d-rh-rechts - 930/002 s-lh-links

D \varnothing 425 mm	P 50 mm
d1 nr. 10	d1 \varnothing 58 mm
d2 nr. 2	d2 \varnothing 23 mm
Ventilata	si-yes-Ja
Ventilated-Belüftet	
Colore	cromato e nero-chrome and black
Colours-Farbe	verchromt und schwarz
Materiale-Material	acciaio inox e plastica stainless steel and plastic Edelstahl und Kunststoff
Kg	1,230

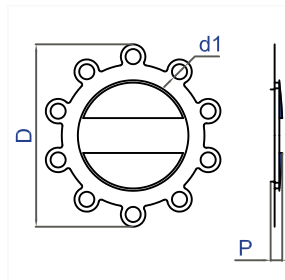

930/100 d-rh-rechts - 930/101 s-lh-links

D \varnothing 387 mm	P 30 mm
d1 nr. 10	d1 \varnothing 32 mm
Ventilata	si-yes-Ja
Ventilated-Belüftet	
Colore	cromato e nero-chrome and black
Colours-Farbe	verchromt und schwarz
Materiale-Material	acciaio inox e plastica stainless steel and plastic Edelstahl und Kunststoff
Kg	0,655

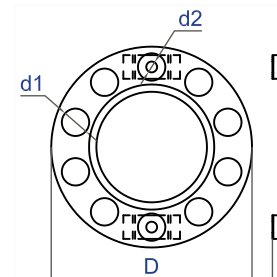

930/200 d|s-rh|lh-rechts|links

D \varnothing 425 mm	P 40 mm
d1 nr. 10	d1 \varnothing 58 mm
d2 nr. 2	d2 \varnothing 23 mm
Ventilata	no-nein
Ventilated-Belüftet	
Colore	cromato-chrome-verchromt
Colours-Farbe	
Materiale-Material	acciaio inox-stainless steel Edelstahl
Kg	1,155



IT Robot di foratura e taglio laser
EN Drilling robot and laser cutting
DE Läserbohrung und Schneideroboter



applicabile a | suitable to | verwendbar für

57

146

SCANIA R 2010 CG-CR

applicabile a | suitable to | verwendbar für:

SCANIA R 2010 CG-CR

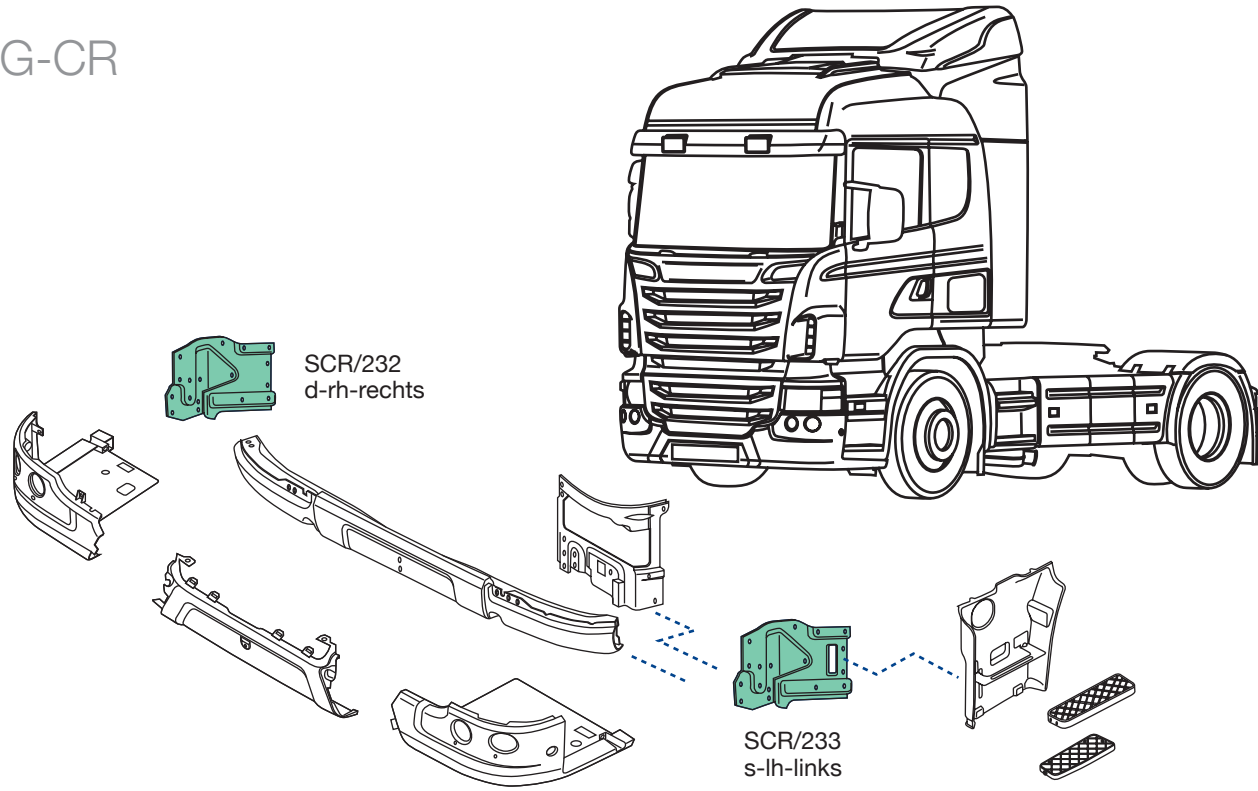

SCR/232
O.E.M. 1431585



SCR/233
O.E.M. 1431584

(*) Larghezza telaio mm 1020 - chassis width 1020 mm
 Chassis: Breite 1020 Millimeter (mm)

940/115
 protezione fendinebbia
 kit 4 pz.
 foglamp protection
 kit 4 pcs.
 Nebelscheinwerferschutz
 Satz 4 st.

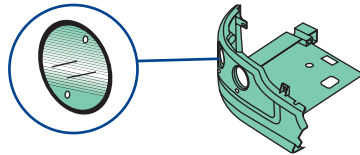
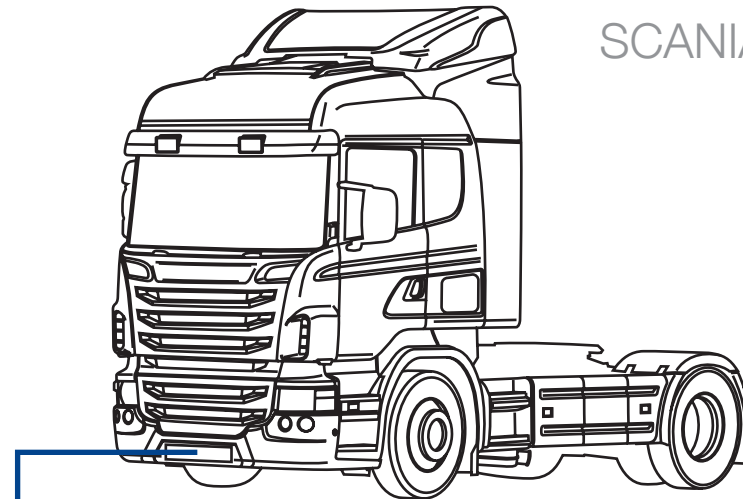

146/ 94(*)

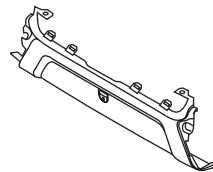

146/ 95(*)

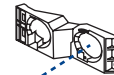

146/ 98 d-rh-rechts
 146/ 99 s-lh-links

SCR/190
 d|s-rh|lh
 rechts|links

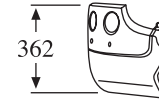

146/ 94
 O.E.M. 1884915
146/ 95
 O.E.M. 1884914

146/ 98
 O.E.M. 2127432
146/ 99
 O.E.M. 2127431

940/115
 O.E.M. -

SCR/190
 O.E.M. 1923152

applicabile a | suitable to | verwendbar für:

SCANIA R 2010 CG-CR

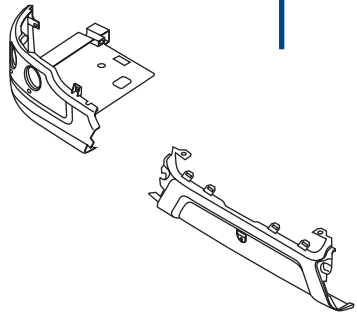
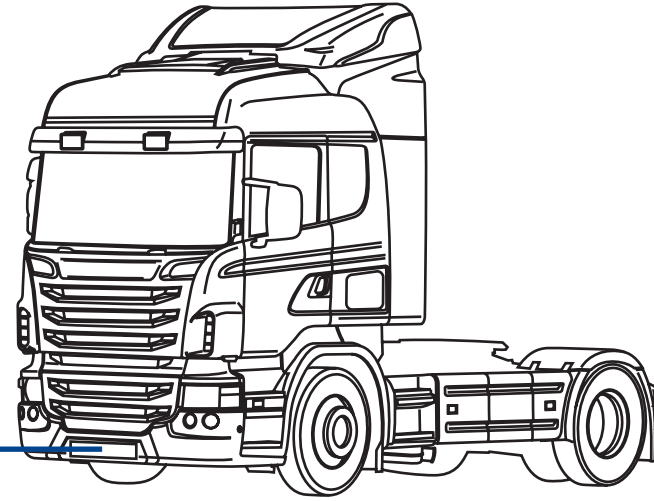

SCR/ 97
d|s-rh|lh
rechts|links

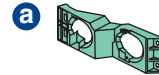
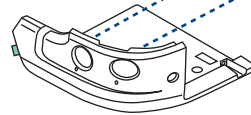

SCR/ 98 d-rh-rechts
SCR/ 99 s-lh-links
con cerniera - with hinge - mit Scharnier
(1493381+1509091)

SCR/ 96
d|s-rh|lh
rechts|links

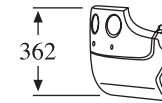

Per paraurti alto - for high bumper
für hohe Stoßfänger



SCR/ 96
O.E.M. 1523509



SCR/ 97
O.E.M. 1523508



SCR/ 98
O.E.M. 1786693
SCR/ 99
O.E.M. 1786692

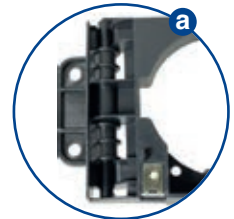

- (1) Predisposto per Active Cruise Control - Active Cruise Control suitable
mit aktiven Abstandwarner
- (*) Larghezza telaio mm 1020 - chassis width 1020 mm
Chassis: Breite 1020 Millimeter (mm)
- (•) Larghezza telaio mm 1140 - chassis width 1140 mm
Chassis: Breite 1140 Millimeter (mm)

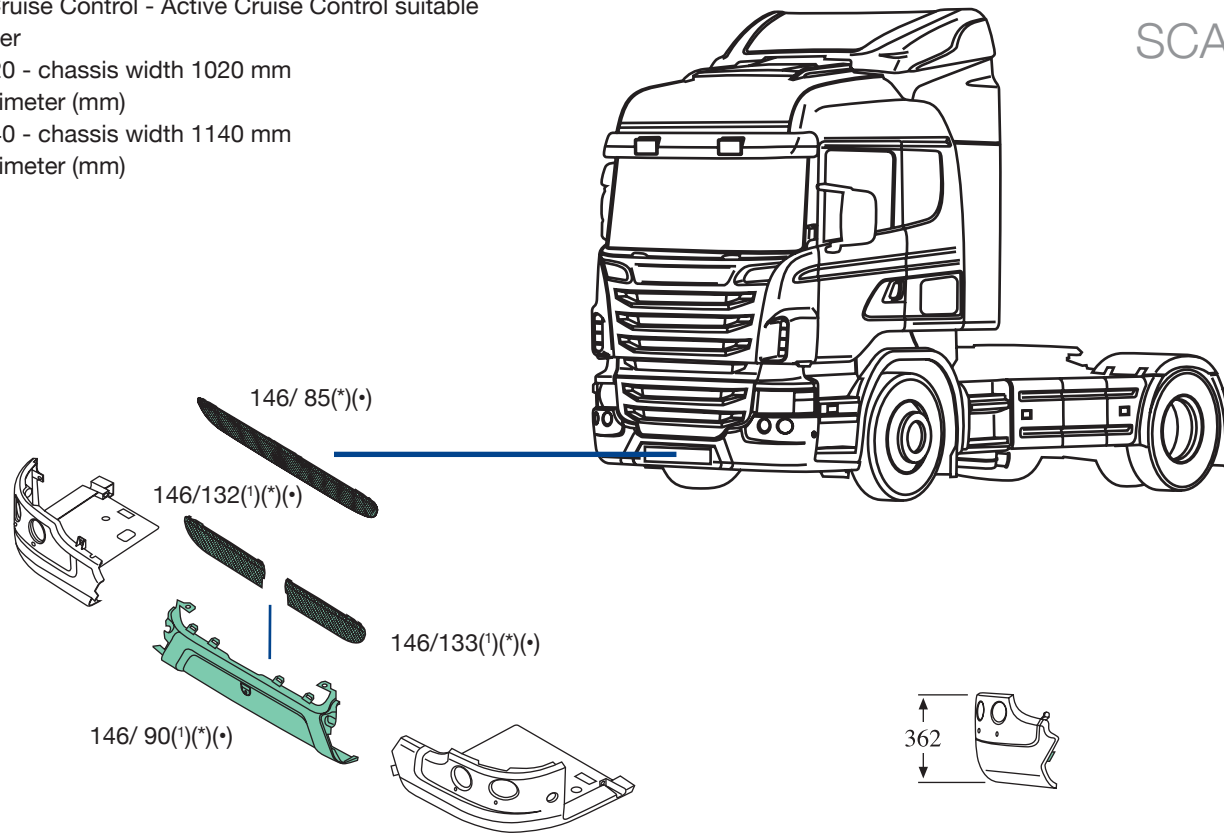

146/85
O.E.M. 1865188



146/90
O.E.M. 1865181



146/132
O.E.M. 1884486



146/133
O.E.M. 1884485

applicabile a | suitable to | verwendbar für:

SCANIA R 2010 CG-CR

(*) Larghezza telaio mm 1020 - chassis width 1020 mm
Chassis: Breite 1020 Millimeter (mm)

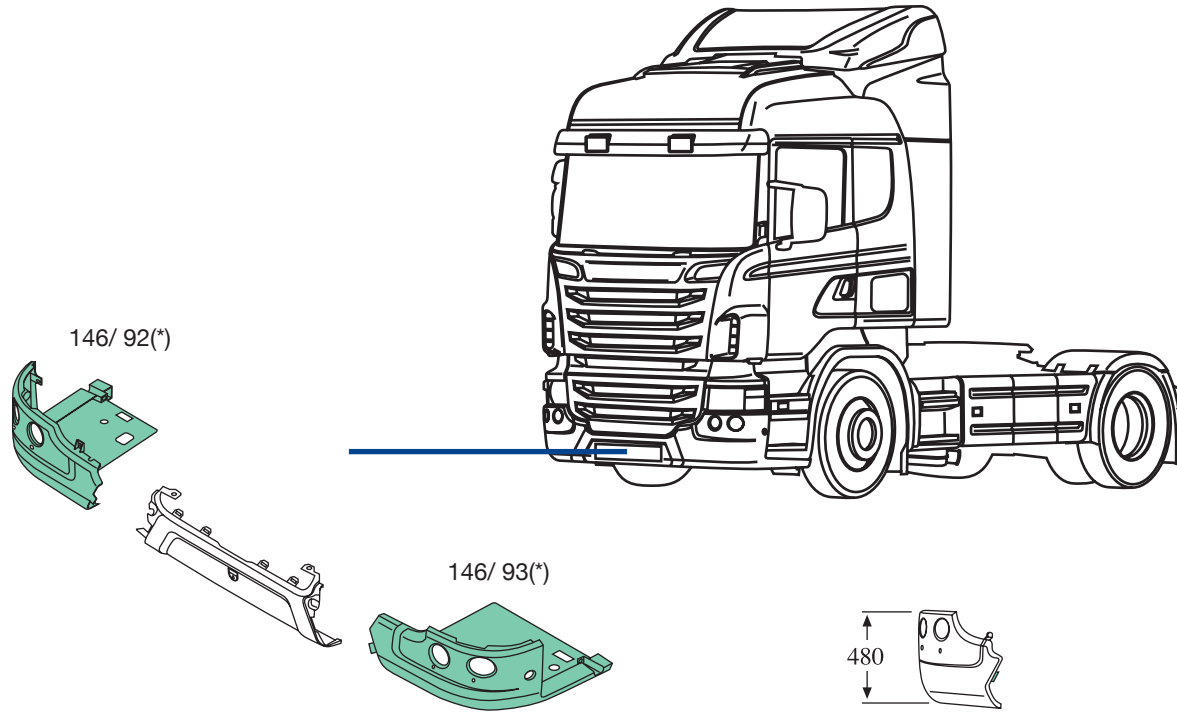

146/92
O.E.M. 1923745
146/93
O.E.M. 1923744

SCANIA R 2010 CG-CR

- (1) Predisposto per Active Cruise Control - Active Cruise Control suitable mit aktiven Abstandwarner
- (*) Larghezza telaio mm 1020 - chassis width 1020 mm
Chassis: Breite 1020 Millimeter (mm)
- (•) Larghezza telaio mm 1140 - chassis width 1140 mm
Chassis: Breite 1140 Millimeter (mm)

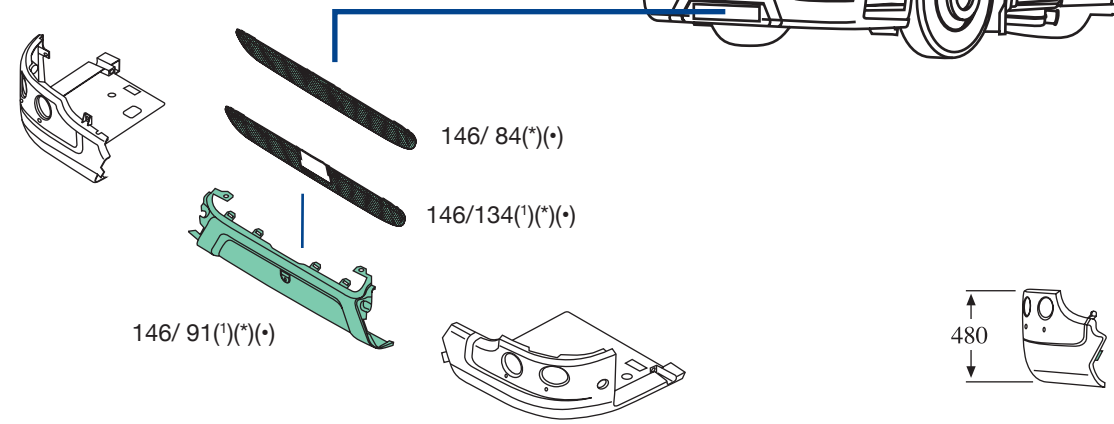
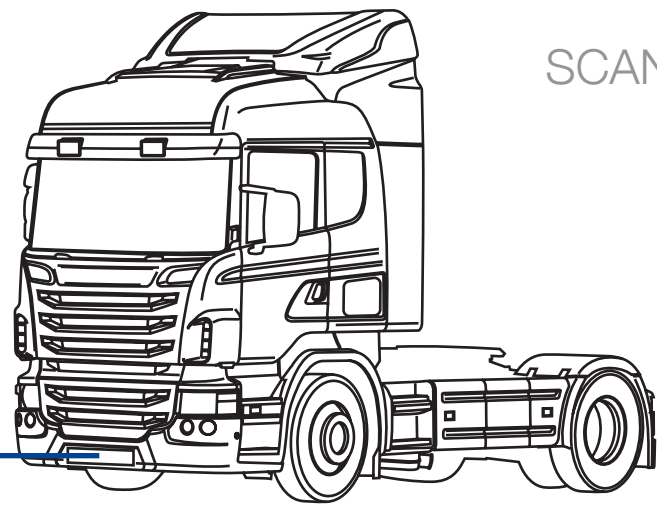

146/ 84
O.E.M. 1865186



146/ 91
O.E.M. 2126392



146/134
O.E.M. 1885996

applicabile a | suitable to | verwendbar für:

SCANIA R 2010 CG-CR

- (1) Predisposto per Active Cruise Control - Active Cruise Control suitable
mit aktiven Abstandwarner
- (*) Larghezza telaio mm 1020 - chassis width 1020 mm
Chassis: Breite 1020 Millimeter (mm)
- (•) Larghezza telaio mm 1140 - chassis width 1140 mm
Chassis: Breite 1140 Millimeter (mm)

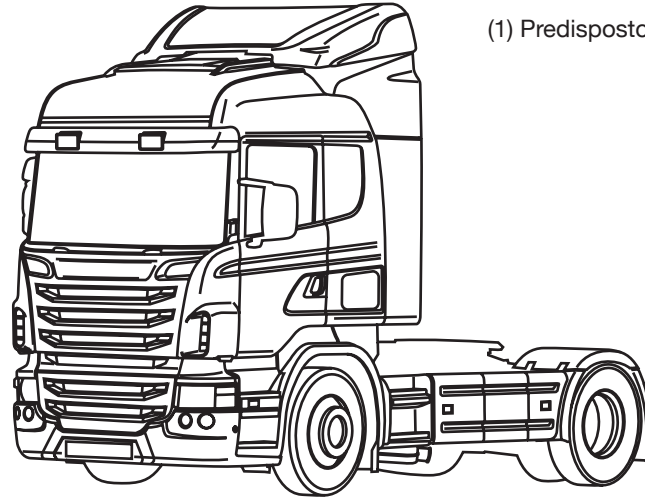

146/ 80⁽¹⁾^(*)^(•)
composto da
composed by
bestehend aus:
146/ 90
146/132
146/133

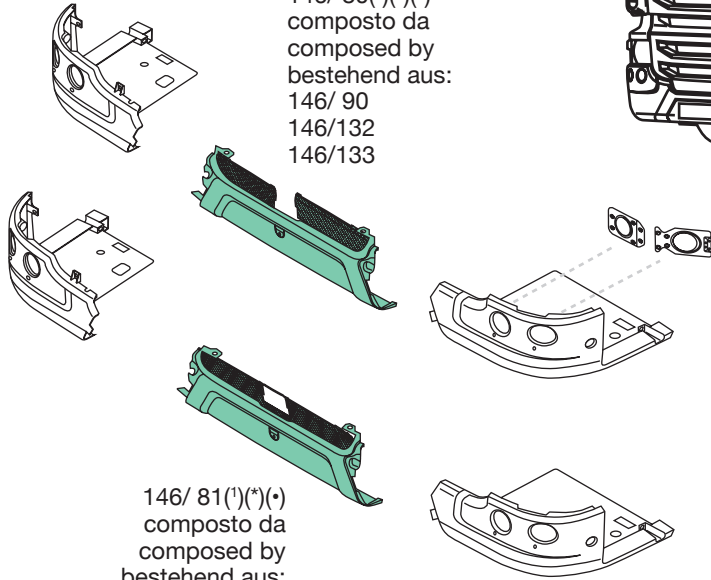

146/ 81⁽¹⁾^(*)^(•)
composto da
composed by
bestehend aus:
146/ 91
146/134

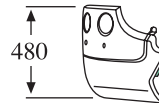
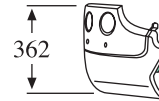

146/ 80
O.E.M. 1884483



146/ 81
O.E.M. 1884482

(*) Larghezza telaio mm 1140 - chassis width 1140 mm
Chassis: Breite 1140 Millimeter (mm)

applicabile a | suitable to | verwendbar für:

SCANIA R 2010 CG-CR

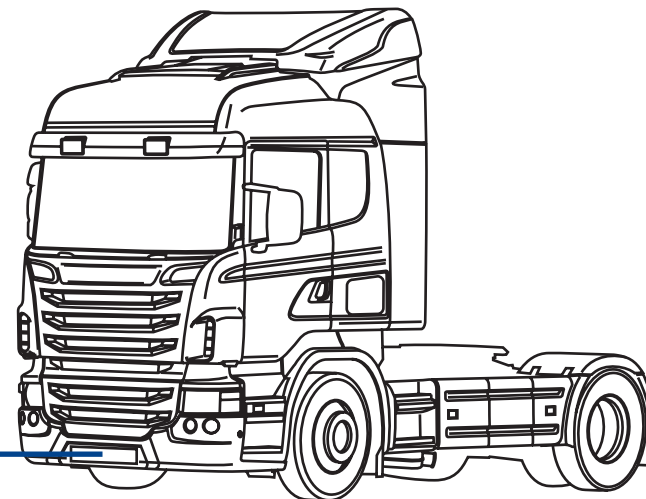

146/194(*)

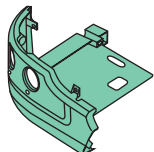

146/192(*)

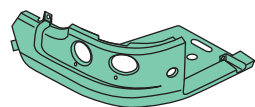
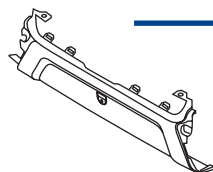
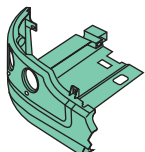

146/195(*)

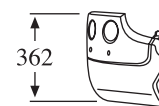

Per paraurti alto - for high bumper - für hohe Stoßfänger

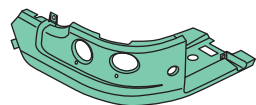
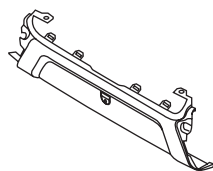

146/193(*)

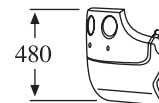

Per paraurti basso - for low bumper - für niedrigen Stoßfänger



146/192
O.E.M. 1923743
146/193
O.E.M. 1923742



146/194
O.E.M. 1865183
146/195
O.E.M. 1865182

applicabile a | suitable to | verwendbar für:

SCANIA R 2010 CG-CR

- (*) Larghezza telaio mm 1020 - chassis width 1020 mm
Chassis: Breite 1020 Millimeter (mm)
- (•) Larghezza telaio mm 1140 - chassis width 1140 mm
Chassis: Breite 1140 Millimeter (mm)

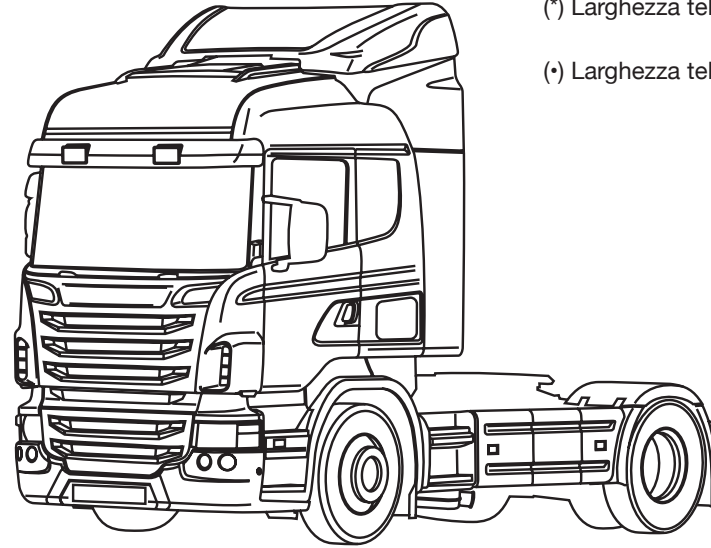

146/198(*)

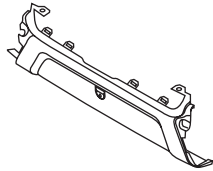
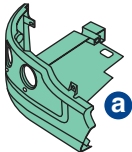
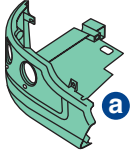

146/196(•)

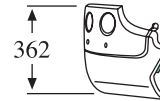
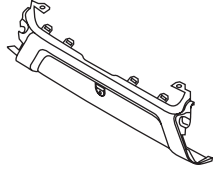

Per paraurti alto - for high bumper - für hohe Stoßfänger

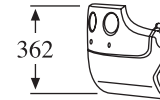

Per paraurti alto - for high bumper - für hohe Stoßfänger

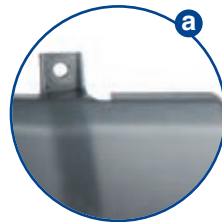

146/196
O.E.M. 1926448

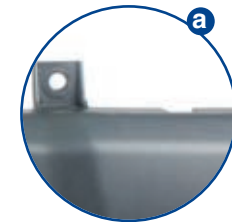

146/198
O.E.M. 1929904

SCANIA R 2010 CG-CR

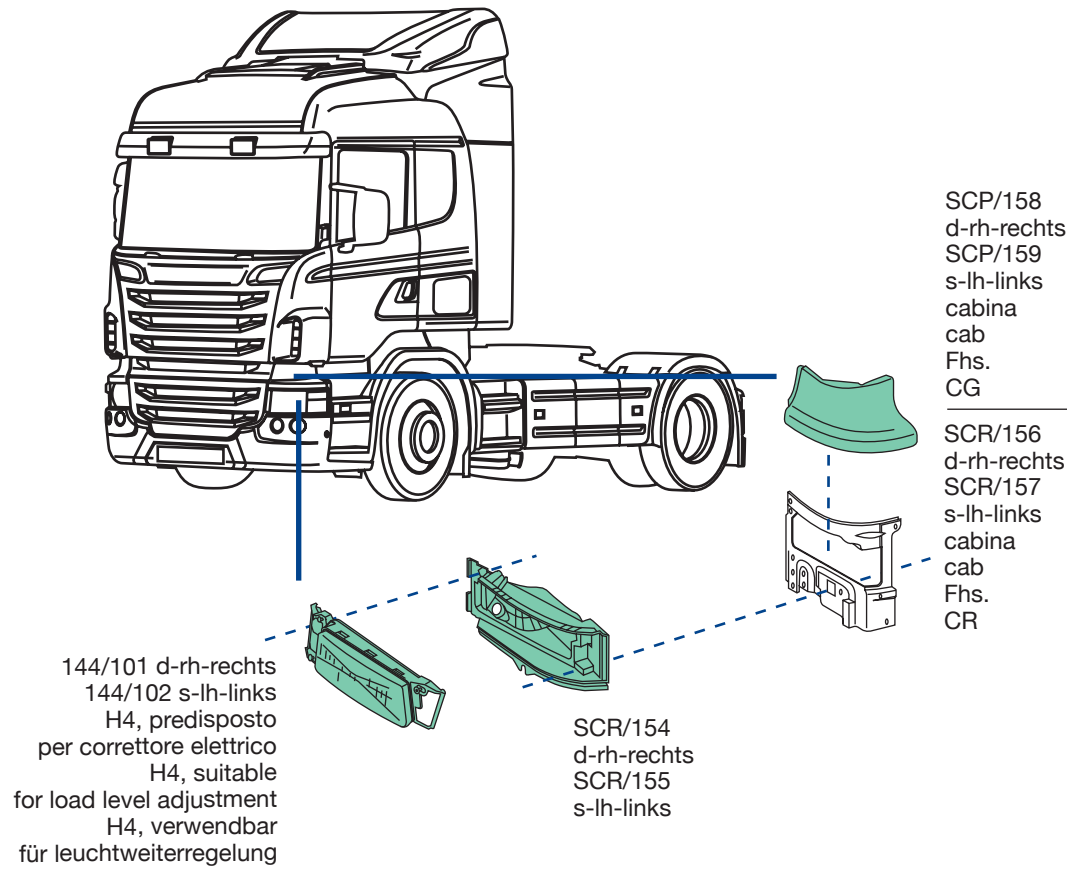

144/101
O.E.M. 1732510
144/102
O.E.M. 1732509



SCR/154
O.E.M. 1936675
SCR/155
O.E.M. 1936674



SCP/158
O.E.M. 1438564
SCP/159
O.E.M. 2124011



SCR/156
O.E.M. 1431923
SCR/157
O.E.M. 2124015

applicabile a | suitable to | verwendbar für:

SCANIA R 2010 CG-CR

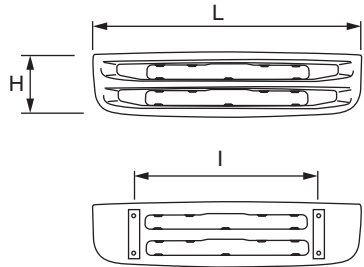

146/250(°)(•)

senza fori per pedana supplementare
without holes for additional step panel
ohne Ausschnitte für zusätzliche Fussplatte
L=1520 H=380 I=1060

146/135(°)(*)

senza fori per pedana supplementare
without holes for additional step panel
ohne Ausschnitte für zusätzliche Fussplatte
L=1520 H=380 I=950

146/150(°)(*)

con fori per pedana supplementare
with holes for additional step panel
mit Ausschnitte für zusätzliche Fussplatte
L=1520 H=380 I=950

146/205(°)(•)

con fori per pedana supplementare
with holes for additional step panel
mit Ausschnitte für zusätzliche Fussplatte
L=1520 H=380 I=1060

(°) Per paraurti basso - for low bumper - für niedrigen Stoßfänger

(*) Larghezza telaio mm 1020 - chassis width 1020 mm - Chassis: Breite 1020 Millimeter (mm)

(•) Larghezza telaio mm 1140 - chassis width 1140 mm - Chassis: Breite 1140 Millimeter (mm)

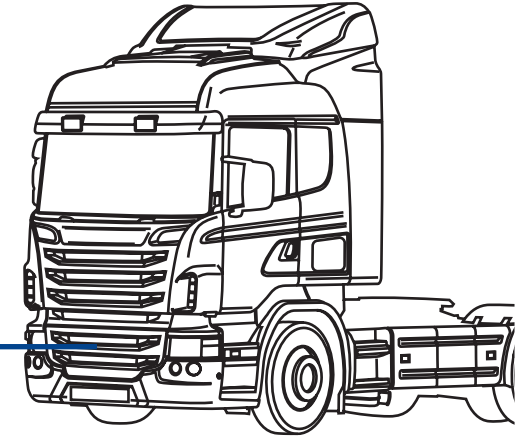
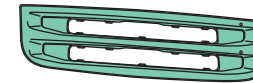
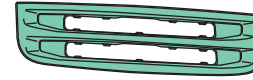

a

a



146/135
O.E.M. 1871667

146/250
O.E.M. 1885932



146/150
O.E.M. 1875851

146/205
O.E.M. 1885944

(a) Variante V8 - fori Ø 8mm | V8 Version - holes Ø 8mm | V8 Version - Ø 8mm Löcher

applicabile a | suitable to | verwendbar für:

SCANIA R 2010 CG-CR

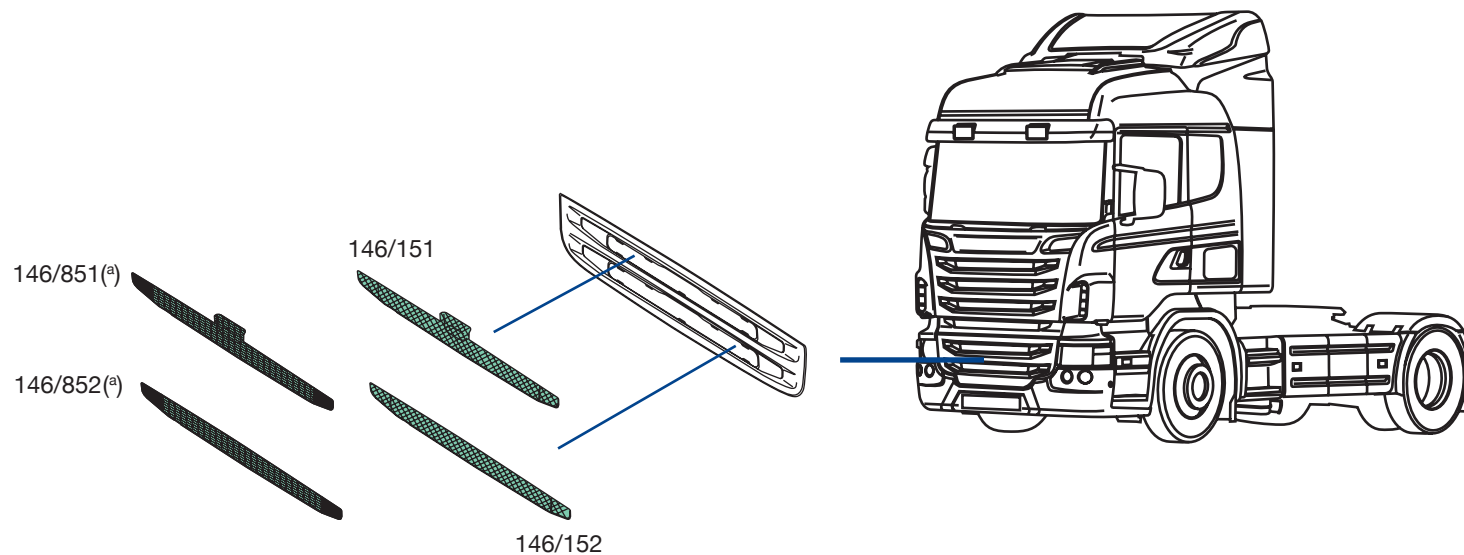

146/151
O.E.M. 1870598



146/152
O.E.M. 1870599



146/851
O.E.M. 1930805



146/852
O.E.M. 1930806

applicabile a | suitable to | verwendbar für:

SCANIA R 2010 CG-CR

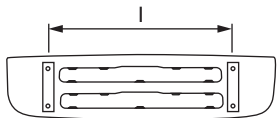
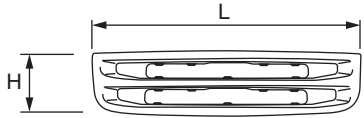

146/255^(*)
senza fori per pedana supplementare
without holes for additional step panel
ohne Ausschnitte für zusätzliche
Fussplatte
L=1520 H=330 I=950

146/265^(*)^(•)
senza fori per pedana supplementare
without holes for additional step panel
ohne Ausschnitte für zusätzliche
Fussplatte
L=1520 H=330 I=1060

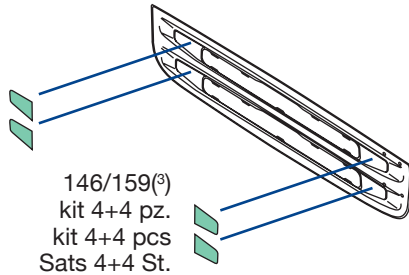

146/159⁽³⁾
kit 4+4 pz.
kit 4+4 pcs
Sats 4+4 St.

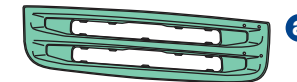

146/850^(*)^(**)
con fori per pedana supplementare
with holes for additional step panel
mit Ausschnitte für zusätzliche Fussplatte
L=1520 H=330 I=950

146/855^(*)^(•)
con fori per pedana supplementare
with holes for additional step panel
mit Ausschnitte für zusätzliche Fussplatte
L=1520 H=330 I=1060



⁽³⁾ Adesivo - Adhesive - selbstklebend

^(**) Per paraurti alto - for high bumper - für hohe Stoßfänger

^(•) Per paraurti basso - for low bumper - für niedrigen Stoßfänger

^(*) Larghezza telaio mm 1020 - chassis width 1020 mm - Chassis: Breite 1020 Millimeter (mm)

^(•) Larghezza telaio mm 1140 - chassis width 1140 mm - Chassis: Breite 1140 Millimeter (mm)



146/159
O.E.M. 1900636 + 1900634
1900635 + 1900633



146/255
O.E.M. 1875843

146/265
O.E.M. 1885940



146/850
O.E.M. 1875858

146/855
O.E.M. 1885949

(^a) Variante V8 - fori Ø 8mm | V8 Version - holes Ø 8mm | V8 Version - Ø 8mm Löcher

applicabile a | suitable to | verwendbar für:

SCANIA R 2010 CG-CR

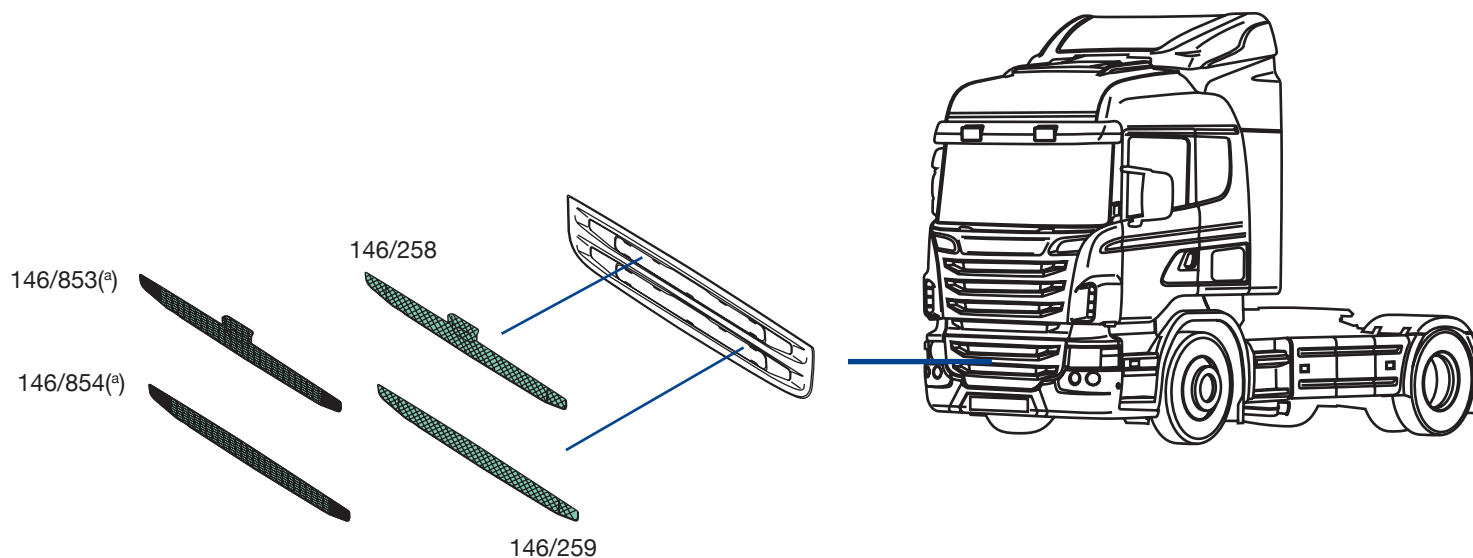

146/258
O.E.M. 1875846

146/259
O.E.M. 1875847

146/853
O.E.M. 1930811

146/854
O.E.M. 1930812

applicabile a | suitable to | verwendbar für:

SCANIA R 2010 CG-CR

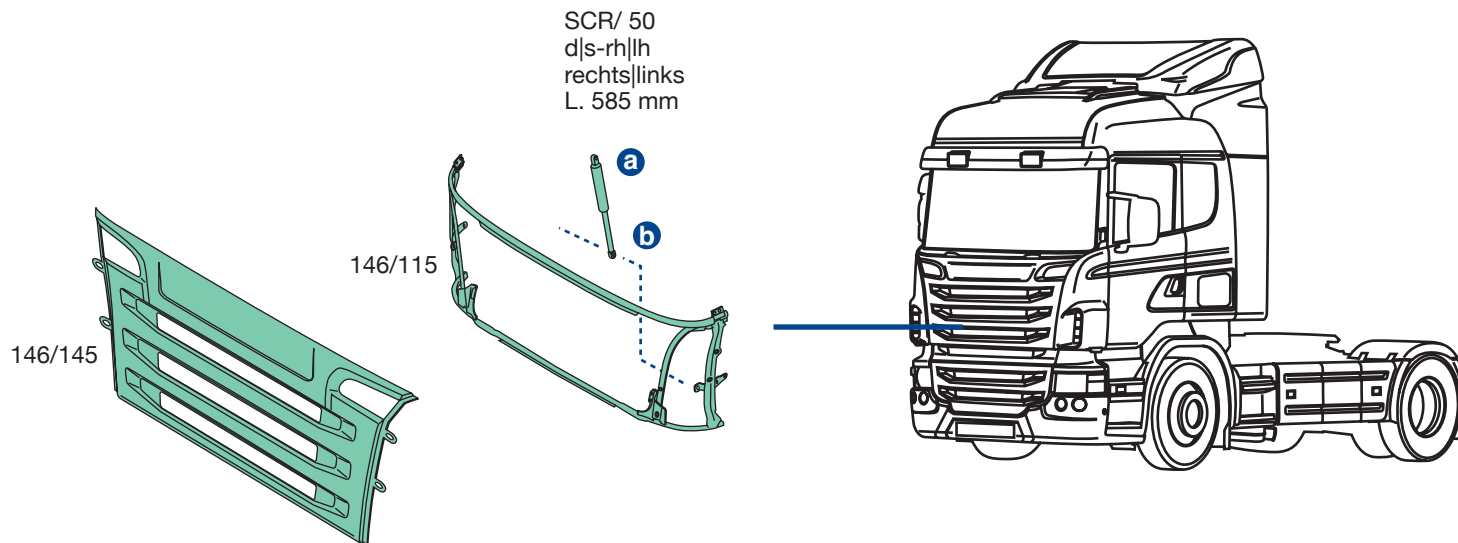

146/115
O.E.M. 2269451



146/145
O.E.M. 1872158



SCR/ 50
O.E.M. 1435542

SCANIA R 2010 CG-CR

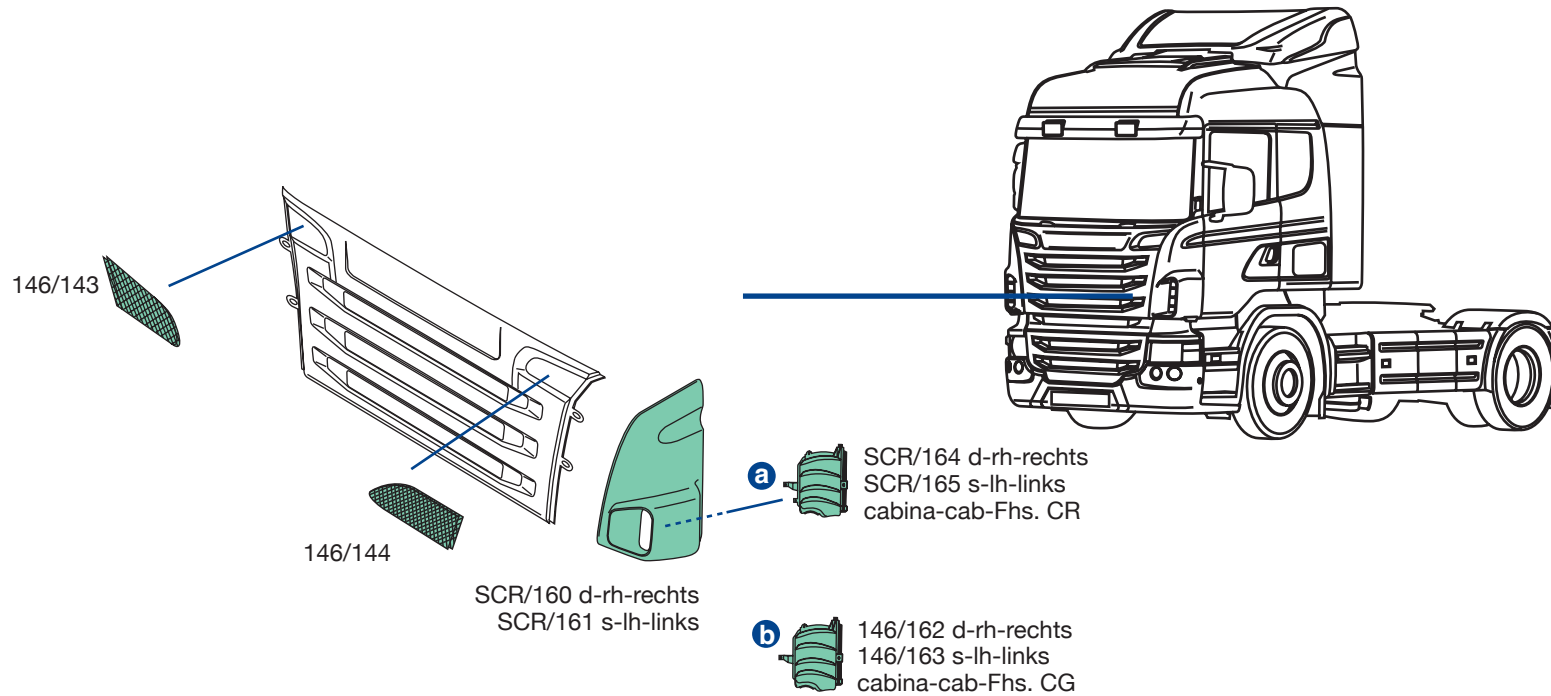

146/143
O.E.M. 1870596
146/144
O.E.M. 1870595



146/162
O.E.M. 1856476
146/163
O.E.M. 1856477

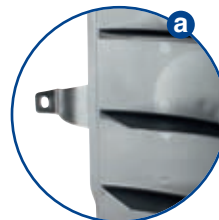

SCR/160
O.E.M. 1751406
SCR/161
O.E.M. 1751405



SCR/164
O.E.M. 1856474
SCR/165
O.E.M. 1856475

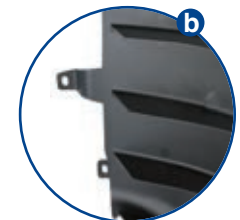

applicabile a | suitable to | verwendbar für:

SCANIA R 2010 CG-CR

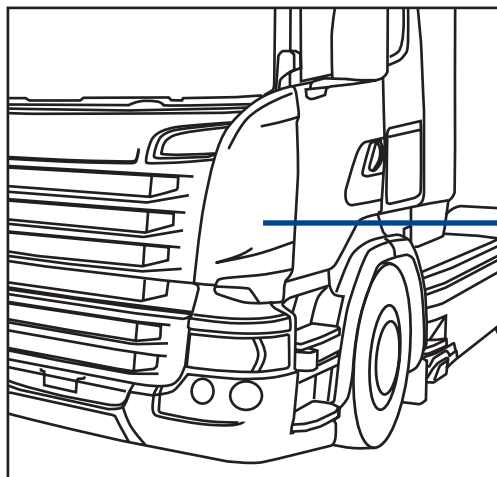

146/138 d-rh-rechts
146/139 s-lh-links



146/160 d-rh-rechts
146/161 s-lh-links

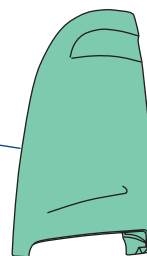

146/138
O.E.M. 2246330
146/139
O.E.M. 2246329



146/160
O.E.M. 2055972
146/161
O.E.M. 2055973

SCANIA R 2010 CG-CR

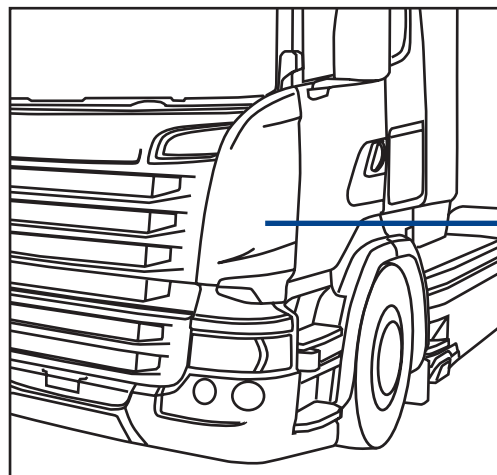

146/164 d-rh-rechts
146/165 s-lh-links

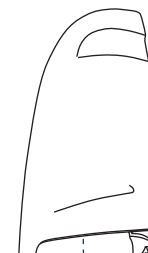
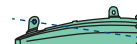

146/166 d-rh-rechts
146/167 s-lh-links
cabina
cab
Fhs.
CR



146/866 (a) d-rh-rechts
146/867 (a) s-lh-links
cabina
cab
Fhs.
CR



146/164
O.E.M. 2126956
146/165
O.E.M. 2126955



146/166
O.E.M. 2162653
146/167
O.E.M. 2162652



146/866
O.E.M. 2097977
146/867
O.E.M. 2097976

applicabile a | suitable to | verwendbar für:

SCANIA R 2010 CG-CR

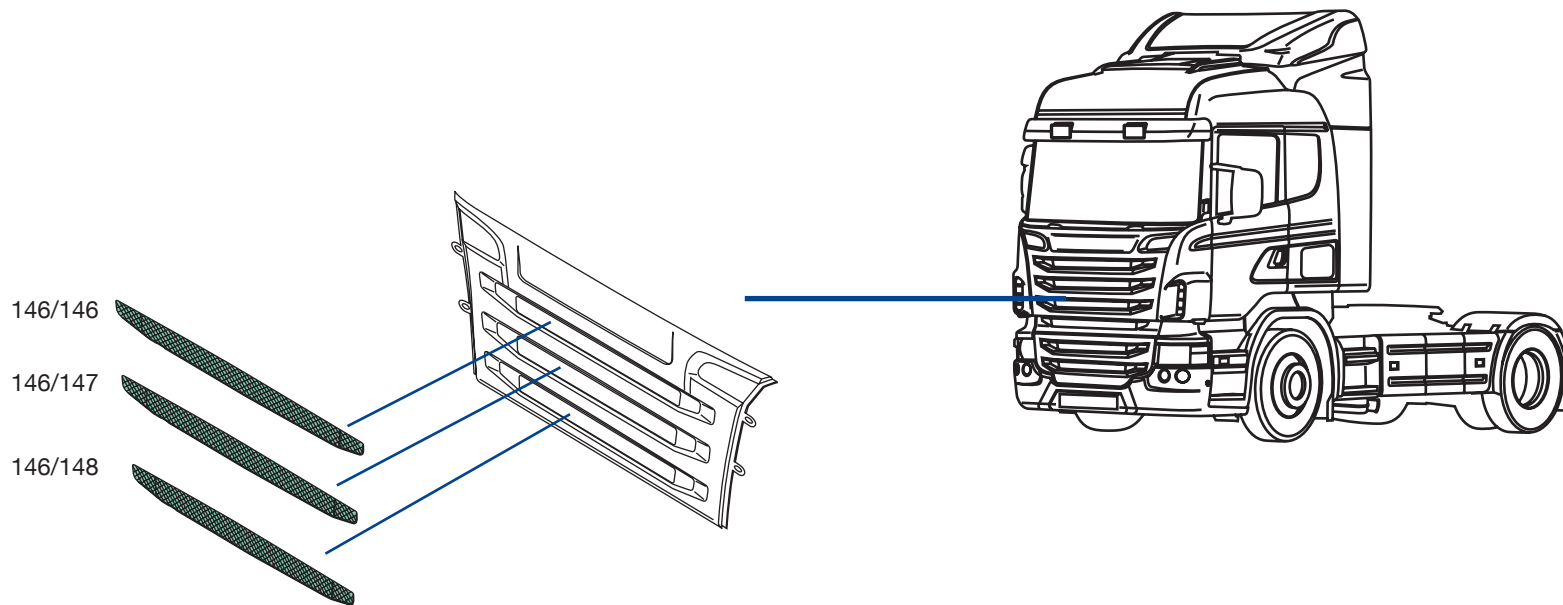

146/146
O.E.M. 1870592



146/147
O.E.M. 1870593



146/148
O.E.M. 1870594

(a) Variante V8 - fori Ø 8mm | V8 Version - holes Ø 8mm | V8 Version - Ø 8mm Löcher

applicabile a | suitable to | verwendbar für:

SCANIA R 2010 CG-CR

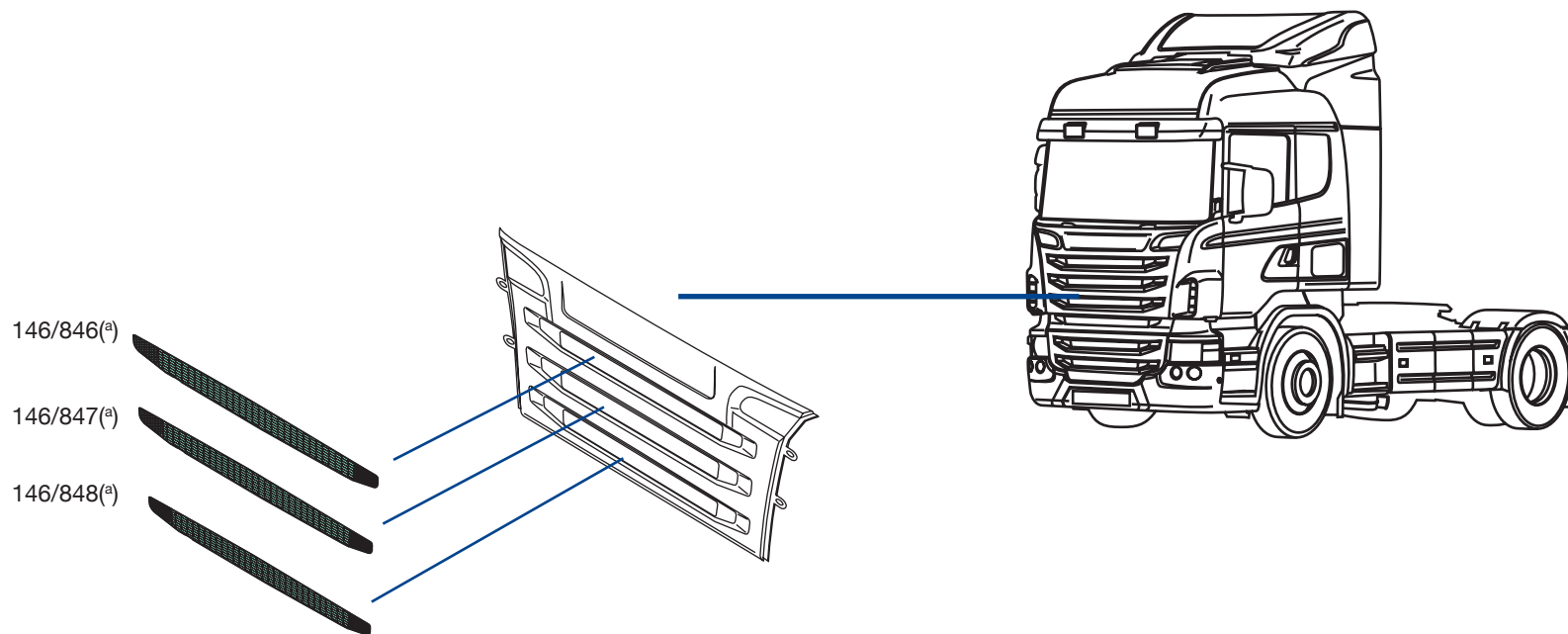

146/846
O.E.M. 1930792



146/847
O.E.M. 1930793



146/848
O.E.M. 1930794

applicabile a | suitable to | verwendbar für:

SCANIA R 2010 CG-CR

(a) Variante V8 - fori Ø 8mm | V8 Version - holes Ø 8mm | V8 Version - Ø 8mm Löcher

146/841^(a)
cabina
cab
Fhs.
CR

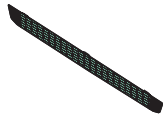

146/141
cabina
cab
Fhs.
CR

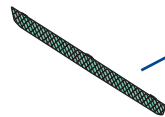

146/140
cabina
cab
Fhs.
CR

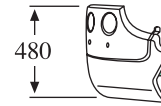
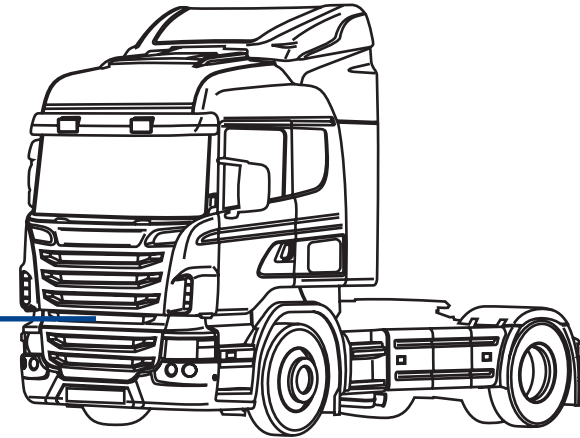
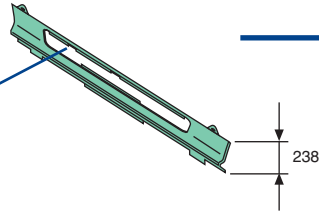

per paraurti basso
for low bumper
für niedrigen Stoßfänger



146/140
O.E.M. 1872159



146/141
O.E.M. 1870597



146/841
O.E.M. 1930799

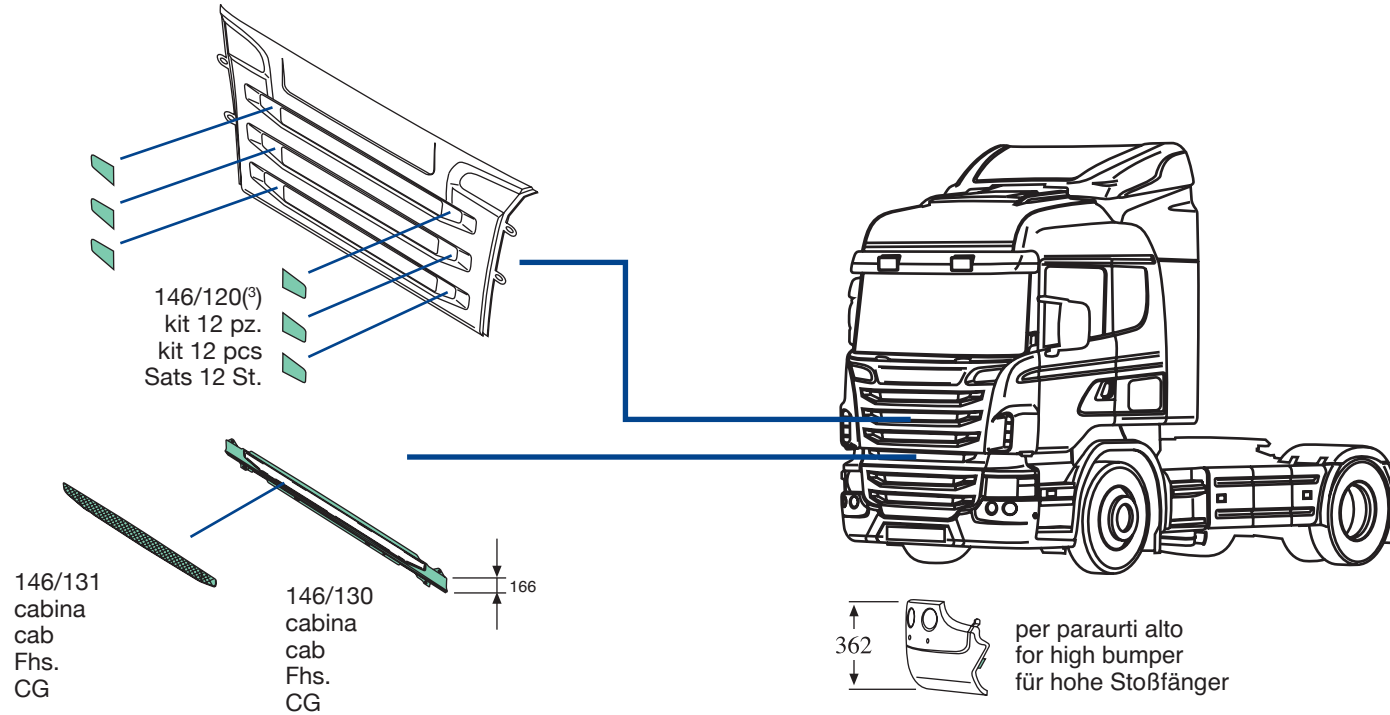

146/120
O.E.M. 2146221 + 2146222



146/130
O.E.M. 1872160



146/131
O.E.M. 1890176

applicabile a | suitable to | verwendbar für:

SCANIA R 2010 CG-CR

SCR/ 2 d-rh-rechts
SCR/ 3 s-lh-links
lastrata, con cerniere
paneled, with hinges
rohbautür, mit Scharnier

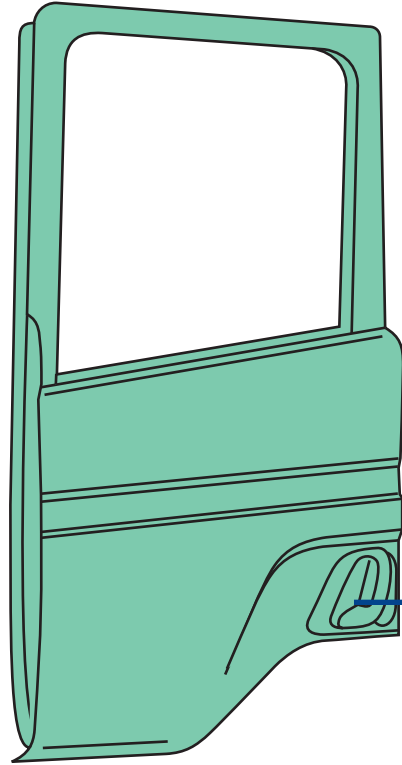

144/194 d-rh-rechts
144/195 s-lh-links

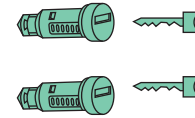
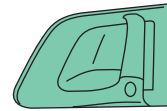

144/196
d|s-rh|lh
rechts|links

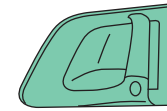

SCR/194 d-rh-rechts
SCR/195 s-lh-links



SCR/ 2
O.E.M. 1476535
SCR/ 3
O.E.M. 1476534



144/194
O.E.M. 2145648
144/195
O.E.M. 2145647



144/196
O.E.M. 1485072



SCR/194
O.E.M. -
SCR/195
O.E.M. -

SCANIA R 2010 CG-CR

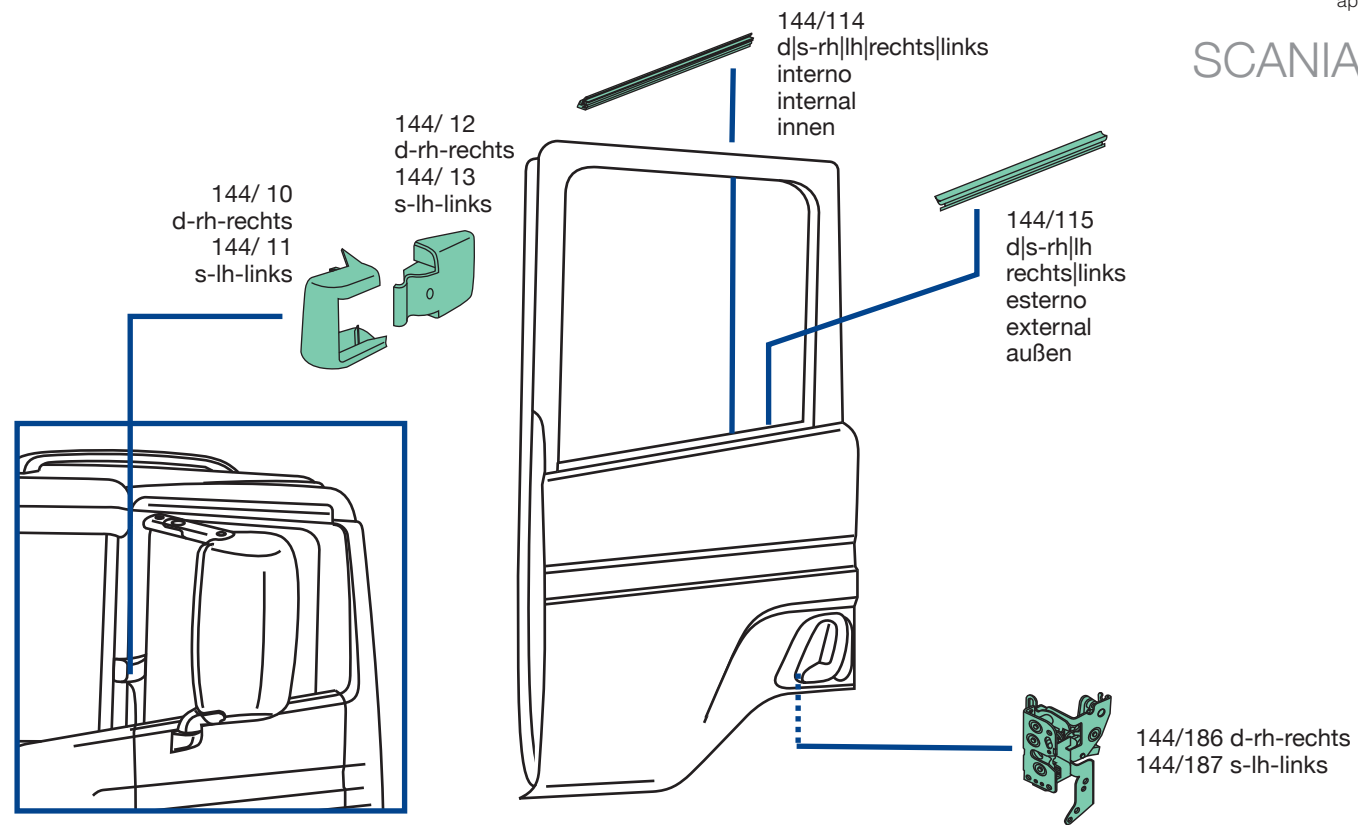

144/ 10
O.E.M. 1472832
144/ 11
O.E.M. 1472833



144/ 12
O.E.M. 1346940
144/ 13
O.E.M. 1346939



144/114
O.E.M. 1865520



144/115
O.E.M. 1865517



144/186
O.E.M. 1867655
144/187
O.E.M. 1867654

applicabile a | suitable to | verwendbar für:

SCANIA R 2010 CG-CR

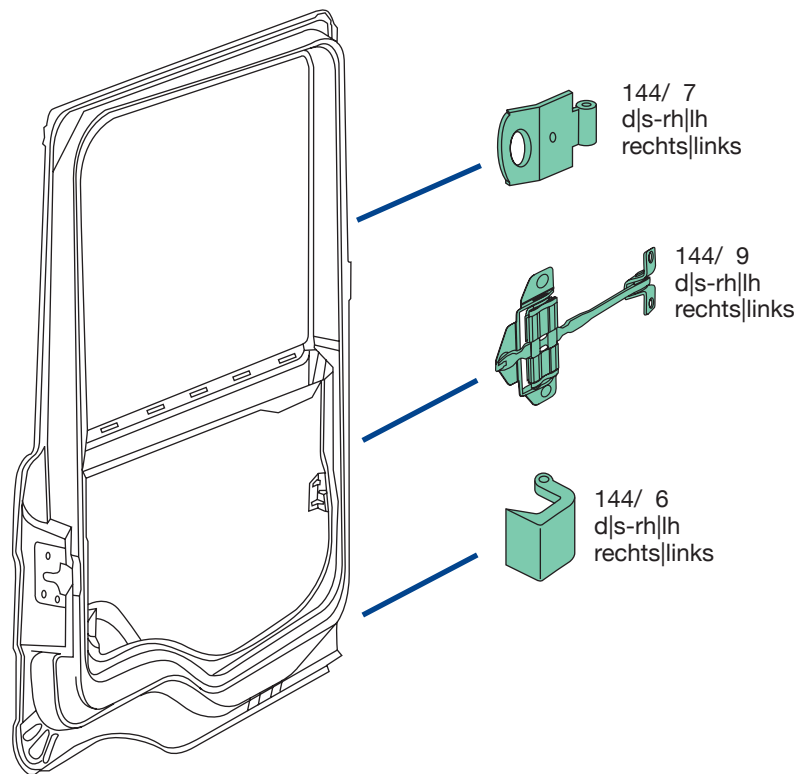

144/ 6
O.E.M. 1426925



144/ 7
O.E.M. 1422292



144/ 9
O.E.M. 1930649

SCANIA R 2010 CG-CR

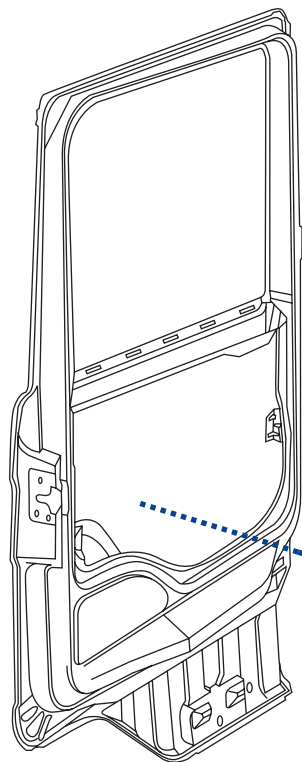

144/174 d-rh-rechts
144/175 s-lh-links
elettrico, senza motorino
electric, without motor
elektrisch, ohne Motor

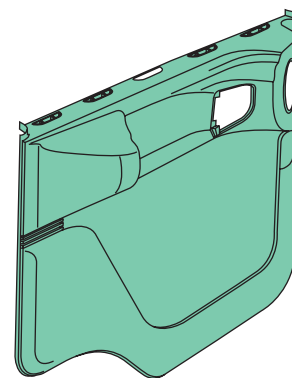
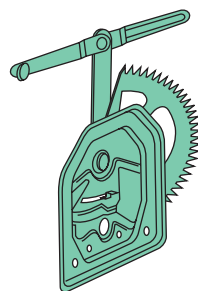

144/ 14 d-rh-rechts
144/ 15 s-lh-links



144/174
O.E.M. 2303352
144/175
O.E.M. 2303349



144/ 14
O.E.M. 1346164
144/ 15
O.E.M. 1346163

applicabile a | suitable to | verwendbar für:

SCANIA R 2010 CG-CR



144/503



|| E4 024107
200x432 mm



applicabilità:
applicable to:
Verwendbar für

SCANIA SERIE 4 1996→2004
SCANIA SERIE R/P/T 2004→

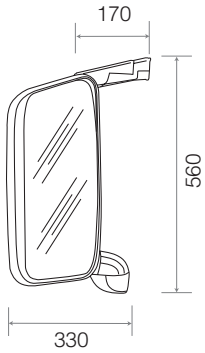

a

-

-

b

144/501

1765985



E4 024107

200x432 mm



d

-

-

f

144/512

1346380



applicabile a | suitable to | verwendbar für:

SCANIA R 2010 CG-CR



144/505

2425815
(1723518)



E4 024107

200x432 mm



applicabilità:
applicable to:
Verwendbar für

SCANIA SERIE 4 1996→2004
SCANIA SERIE R/P/T 2004→

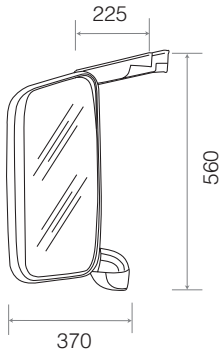

a

-

-

b

144/501

1765985



E4 024107

200x432 mm



d

-

-

f

144/512

1346380



applicabile a | suitable to | verwendbar für:

SCANIA R 2010 CG-CR



144/506

2425816
(1723519)



II

(E4) 024107

200x432 mm



IV

(E4) 024108

160x184 mm



applicabilità:
applicable to:
Verwendbar für

SCANIA SERIE 4 1996→2004
SCANIA SERIE R/P/T 2004→

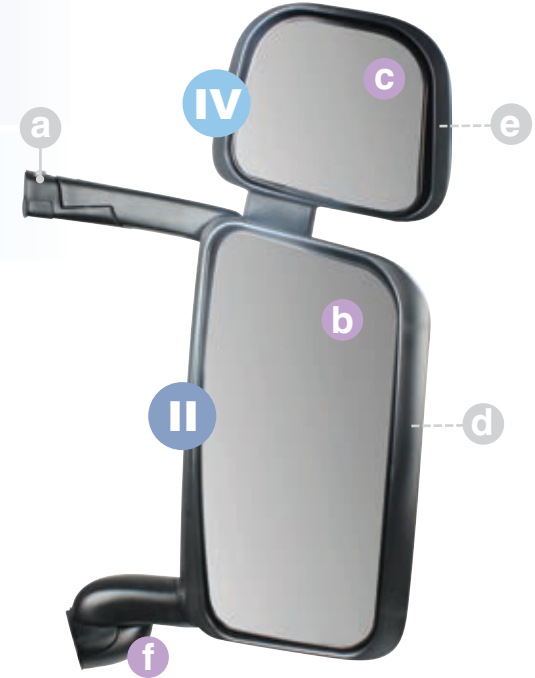
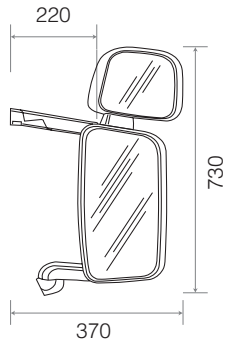

COVIND

















144/510

IV

1765808



260x348 mm

a	-	-							
b	144/501 II	1765985							E4 024107 200x432 mm
c	144/502 IV	1767265							E4 024108 160x184 mm
d	-	-							
e	-	-							
f	144/512	1346380							

applicabile a | suitable to | verwendbar für:

SCANIA R 2010 CG-CR



144/507

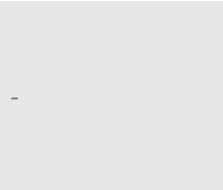

II

E4 024107

200x432 mm



IV

E4 024108

184x160 mm

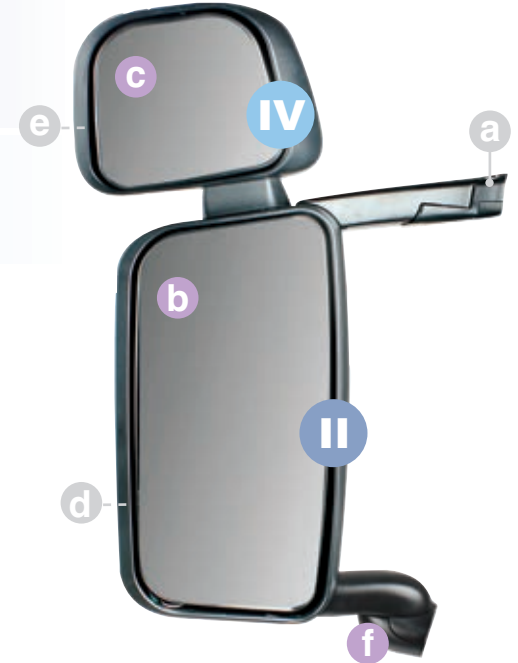

applicabilità:
applicable to:
Verwendbar für

SCANIA SERIE 4 1996→2004
SCANIA SERIE R/P/T 2004→

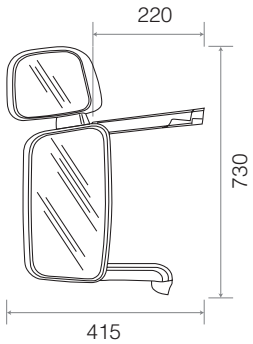

COVIND

144/511

















1765809



260x348 mm

IV

90

a	-	-								
b	144/501	1765985							E4 024107	200x432 mm
II										
c	144/502	1767265							E4 024108	184x160 mm
IV										
d	-	-								
e	-	-								
f	144/512	1346380								

applicabile a | suitable to | verwendbar für:

SCANIA R 2010 CG-CR



144/508



II

E4 024107

200x432 mm



IV

E4 024108

184x160 mm



applicabilità:
applicable to:
Verwendbar für

SCANIA SERIE 4 1996→2004
SCANIA SERIE R/P/T 2004→

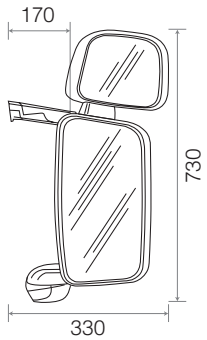

COVIND

144/510

1765808



260x348 mm

a

-

-

b

144/501

1765985



E4 024107

200x432 mm

II

c

144/502

1767265



E4 024108

184x160 mm

IV

d

-

-

e

-

-

f

144/512

1346380



applicabile a | suitable to | verwendbar für:

SCANIA R 2010 CG-CR



144/509



II (E4)024107
200x432 mm



IV (E4)024108
184x160 mm

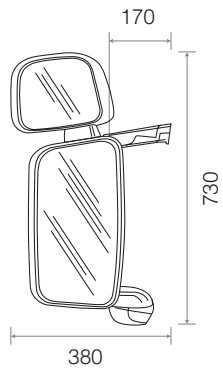

applicabilità:
applicable to:
Verwendbar für

SCANIA SERIE 4 1996→2004
SCANIA SERIE R/P/T 2004→

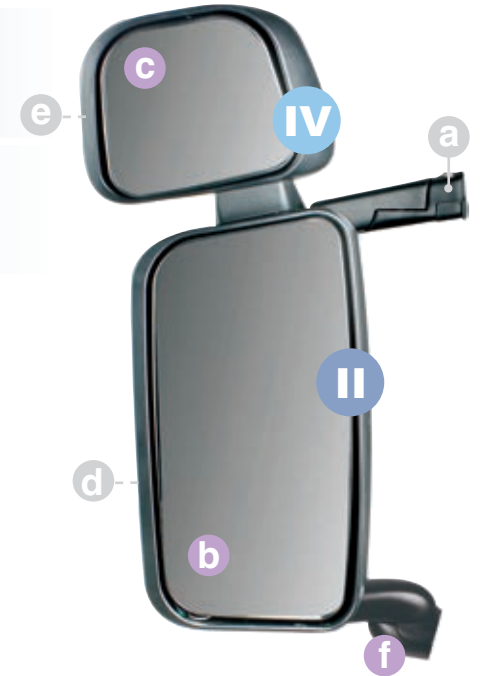

















COVIND

144/511

1765809



260x348 mm

a	-	-							
b	144/501 II	1765985							E4 024107 200x432 mm
c	144/502 IV	1767265							E4 024108 184x160 mm
d	-	-							
e	-	-							
f	144/512	1346380							

applicabile a | suitable to | verwendbar für:

SCANIA R 2010 CG-CR

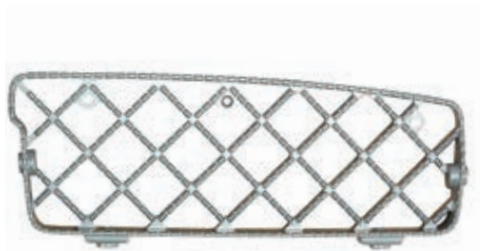
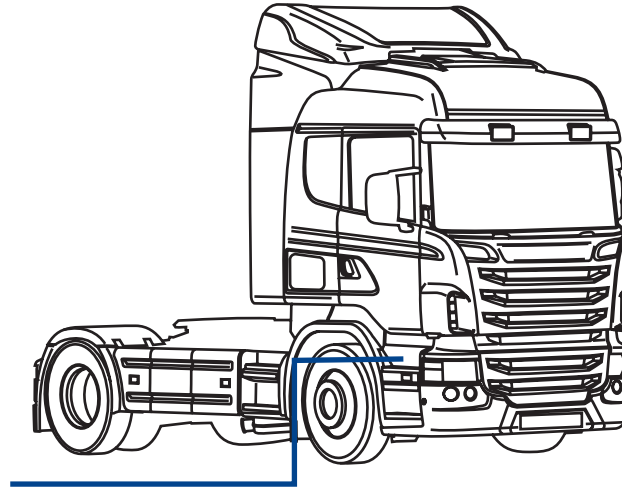
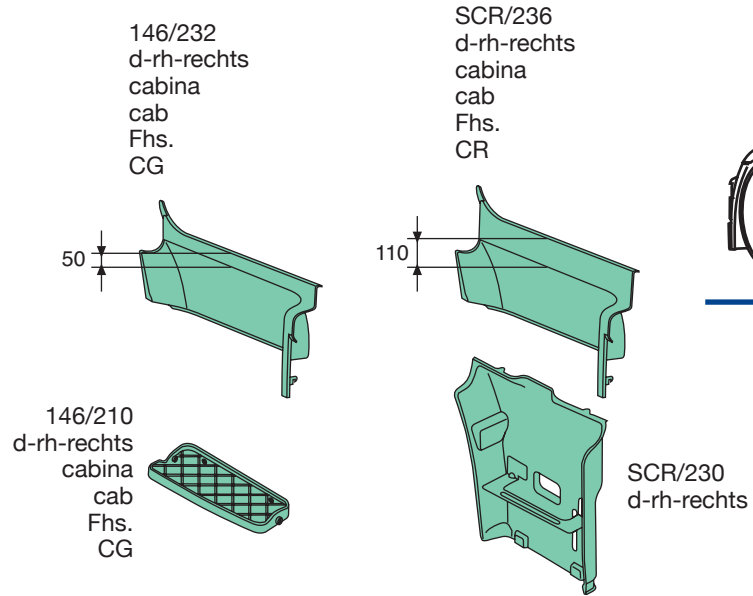

146/210
O.E.M. 1779114



146/232
O.E.M. 1805342



SCR/230
O.E.M. 1854228



SCR/236
O.E.M. 1442654

SCANIA R 2010 CG-CR

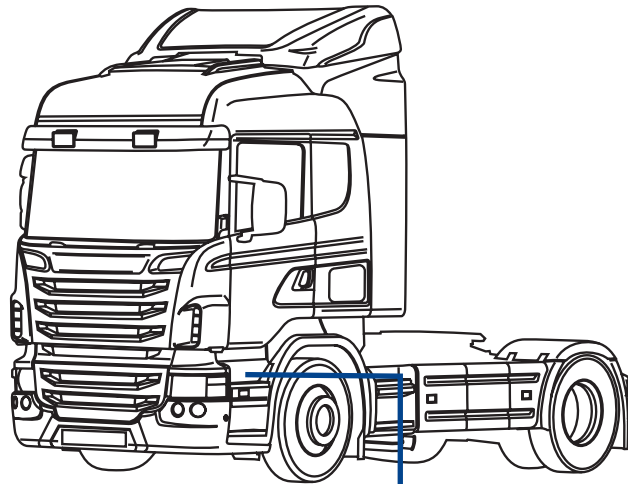

SCR/237
s-lh-links
cabina
cab
Fhs.
CR

146/233
s-lh-links
cabina
cab
Fhs.
CG

SCR/231
s-lh-links

146/211
s-lh-links
cabina
cab
Fhs.
CG

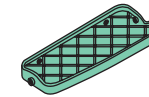
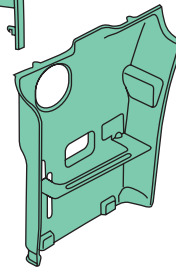
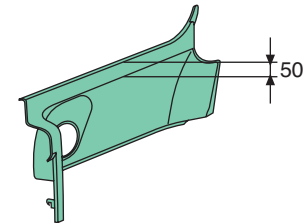
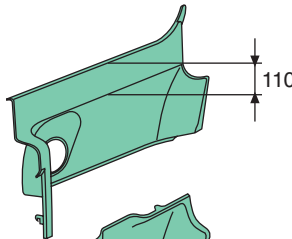

146/211
O.E.M. 1779113



146/233
O.E.M. 1805341



SCR/231
O.E.M. 1854227



SCR/237
O.E.M. 1442653

applicabile a | suitable to | verwendbar für:

SCANIA R 2010 CG-CR

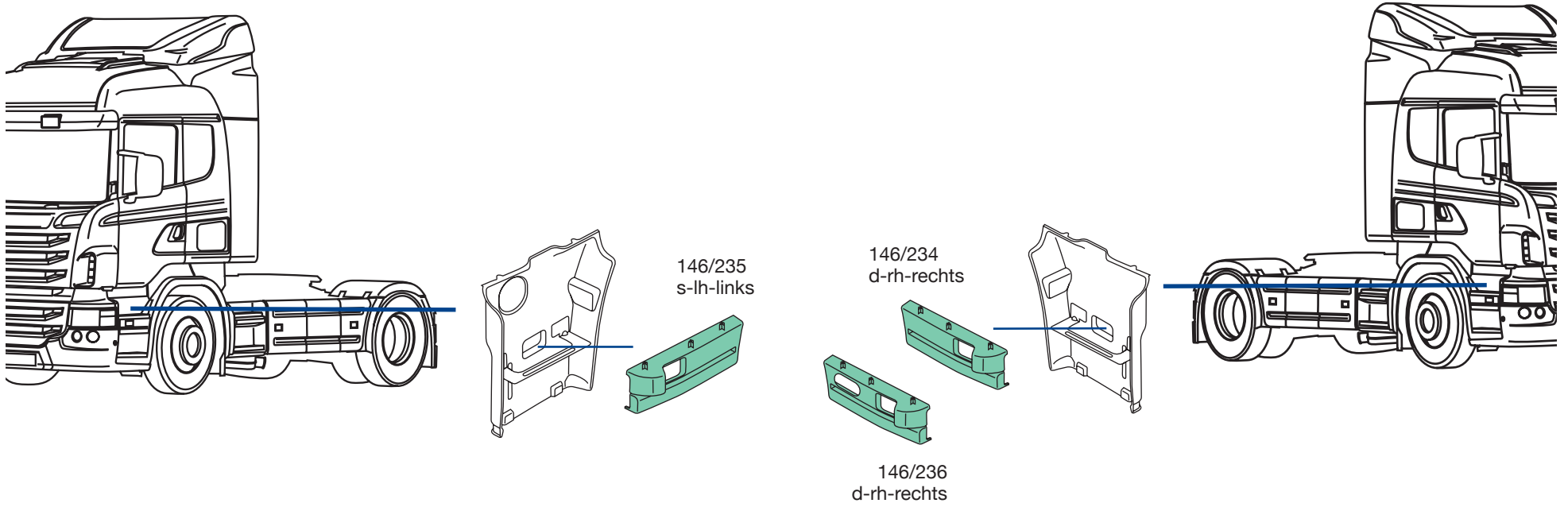

146/234
O.E.M. 1779121



146/235
O.E.M. 1779120



146/236
O.E.M. 1787896

SCANIA R 2010 CG-CR

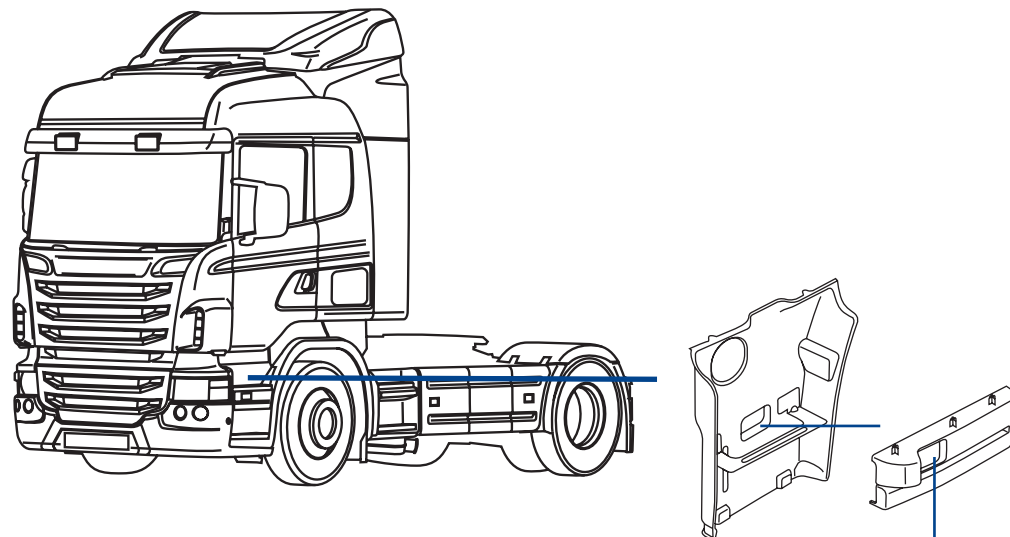

SCR/505
d|s-rh|lh-rechts|links
segnalatore laterale (a lampadina)
side marker (with bulb)
Seiten markierung (mit Glühbirne)

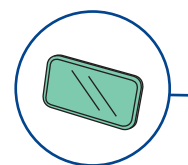

SCR/506
d|s-rh|lh-rechts|links
segnalatore laterale (3 led)
side marker (3 led)
Seiten markierung (3 led)

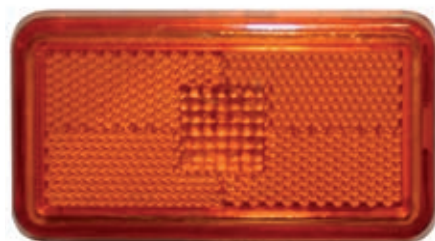

SCR/505
O.E.M. 2052117



SCR/506
O.E.M. 2080828

applicabile a | suitable to | verwendbar für:

SCANIA R 2010 CG-CR

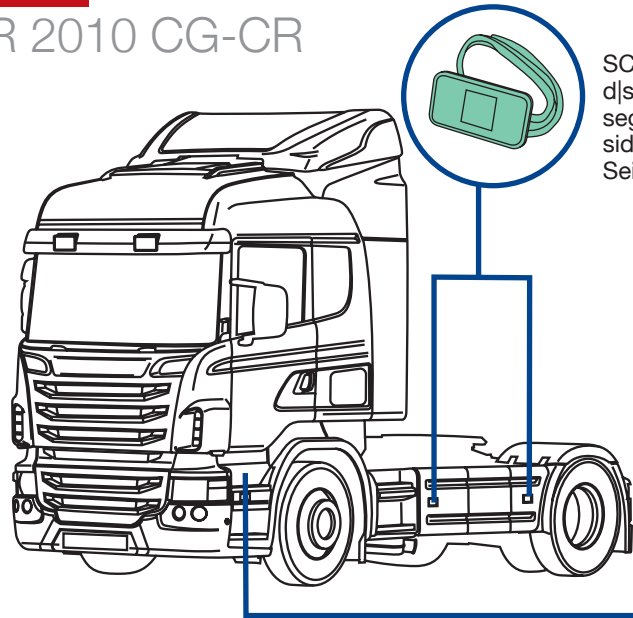

SCR/235
d|s-rh|lh-rechts|links
segnalatore laterale (4 led)
side marker (4 led)
Seiten markierung (4 led)

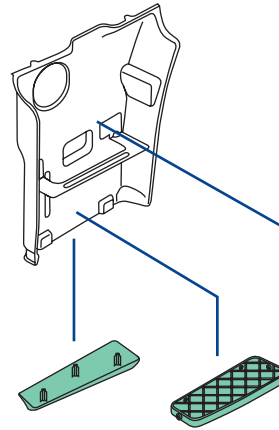

SCR/215
d|s-rh|lh-rechts|links
cabina
cab
Fhs.
CR

SCR/242
d-rh-rechts
SCR/243
s-lh-links

SCR/212
d|s-rh|lh-rechts|links

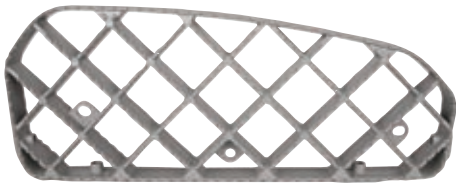

SCR/212
O.E.M. 1535052



SCR/215
O.E.M. 1805447



SCR/242
O.E.M. 1512424
SCR/243
O.E.M. 1512423



SCR/235
O.E.M. 1471599

PDS/360

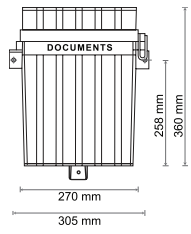

applicabile a | suitable to | verwendbar für:

SCANIA R 2010 CG-CR

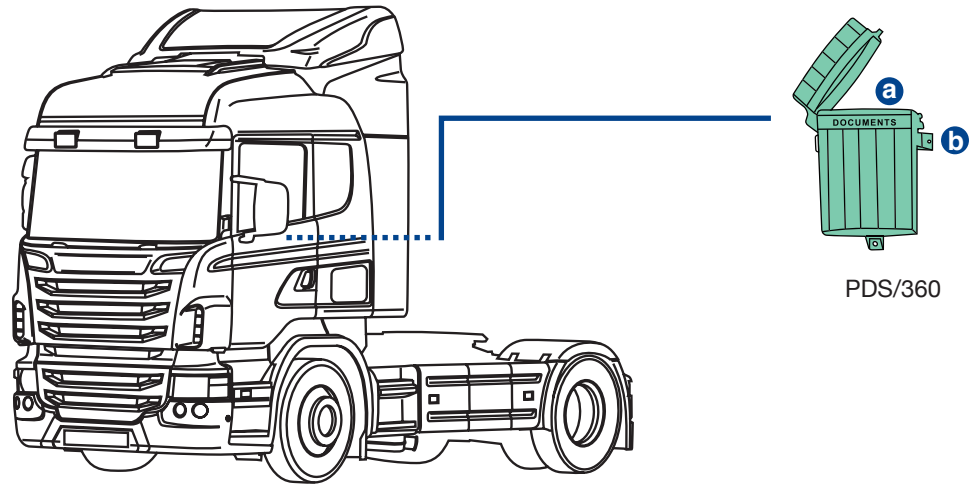

PDS/360
O.E.M. -

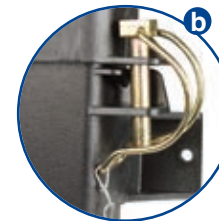

applicabile a | suitable to | verwendbar für:

SCANIA R 2010 CG-CR

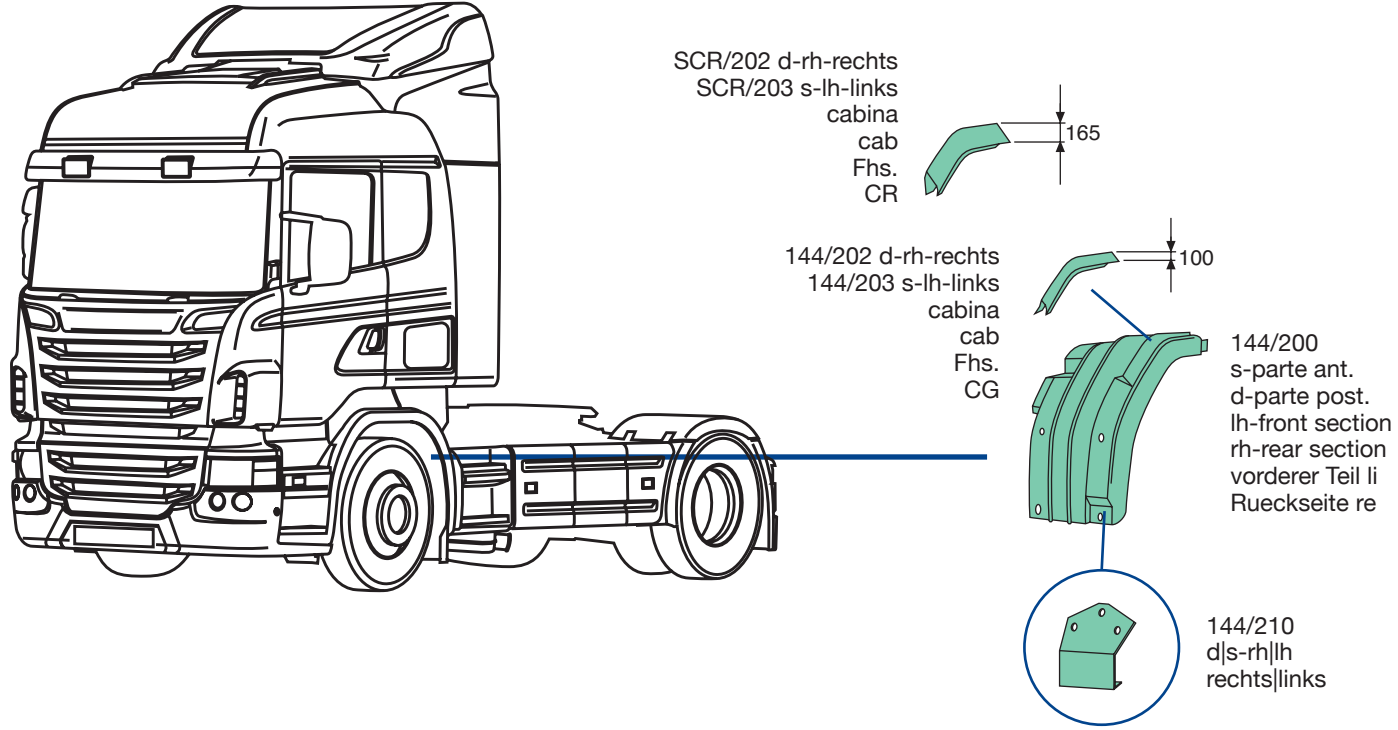

144/200
O.E.M. 1485485



144/202
O.E.M. 1517650
144/203
O.E.M. 1517649



144/210
O.E.M. 1398873



SCR/202
O.E.M. 1431932
SCR/203
O.E.M. 1431931

SCANIA R 2010 CG-CR

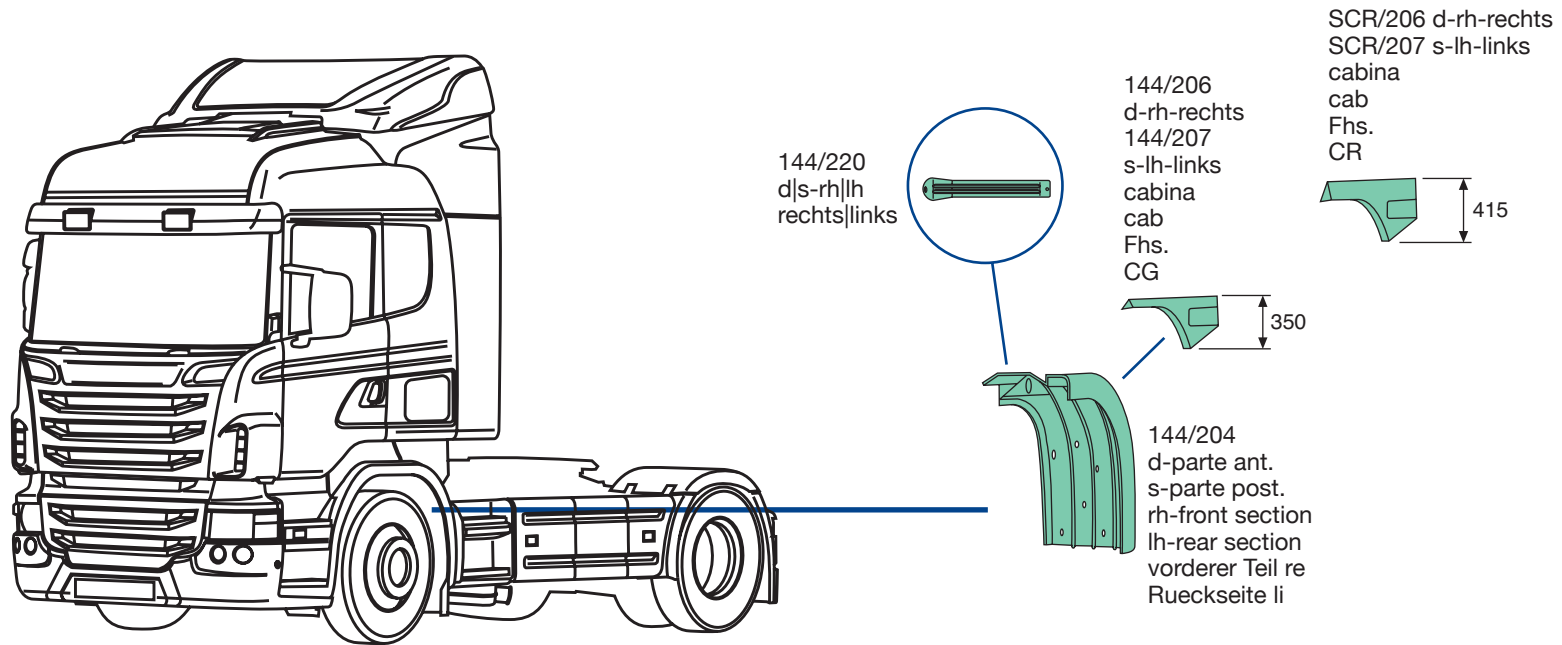

144/204
O.E.M. 1485486



144/206
O.E.M. 1364666
144/207
O.E.M. 1364665



144/220
O.E.M. 1479924



SCR/206
O.E.M. 1431934
SCR/207
O.E.M. 1431933

applicabile a | suitable to | verwendbar für:

SCANIA R 2010 CG-CR

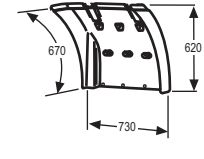
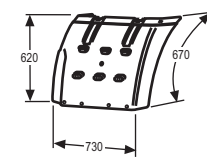
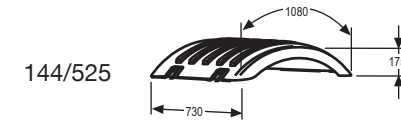
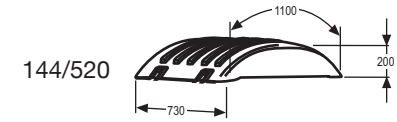
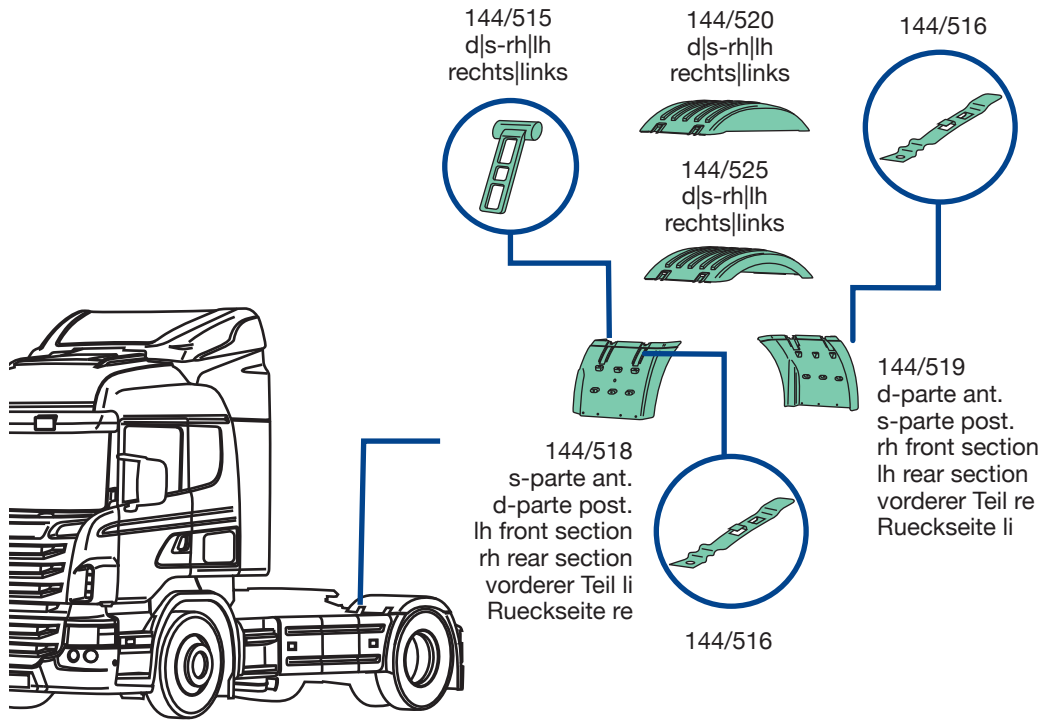

144/515
O.E.M. 1383858



144/516
O.E.M. 2056867

SCANIA R 2010 CG-CR

144/520
O.E.M. 1357601
d|s-rh|lh-rechts|links
grigio, circolare, senza cinghietti
grey, circular, without stretchers
grau, halbrund, ohne Spanngummi



144/518
O.E.M. 1357600
d|s-rh|lh-rechts|links
grigio
grey
grau

144/519
O.E.M. 1357599
d|s-rh|lh-rechts|links
grigio, senza anti-spray
grey, without anti-spray
grau, ohne Spritzschutz



144/525
O.E.M. 1395276
d|s-rh|lh-rechts|links
grigio, semipiatta, senza cinghietti
grey, semi-flat, without stretchers
grau, halbflach, ohne Spanngummi



144/519

144/518

applicabile a | suitable to | verwendbar für:

SCANIA R 2010 CG-CR

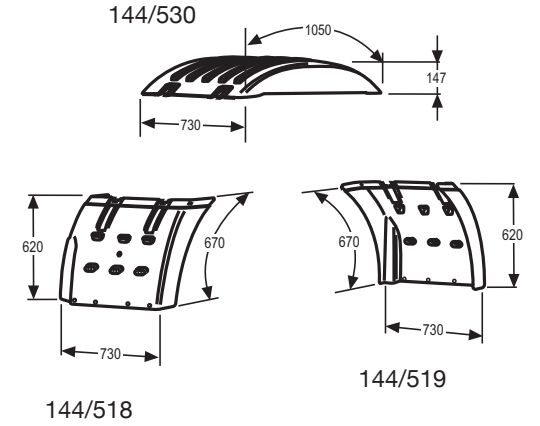
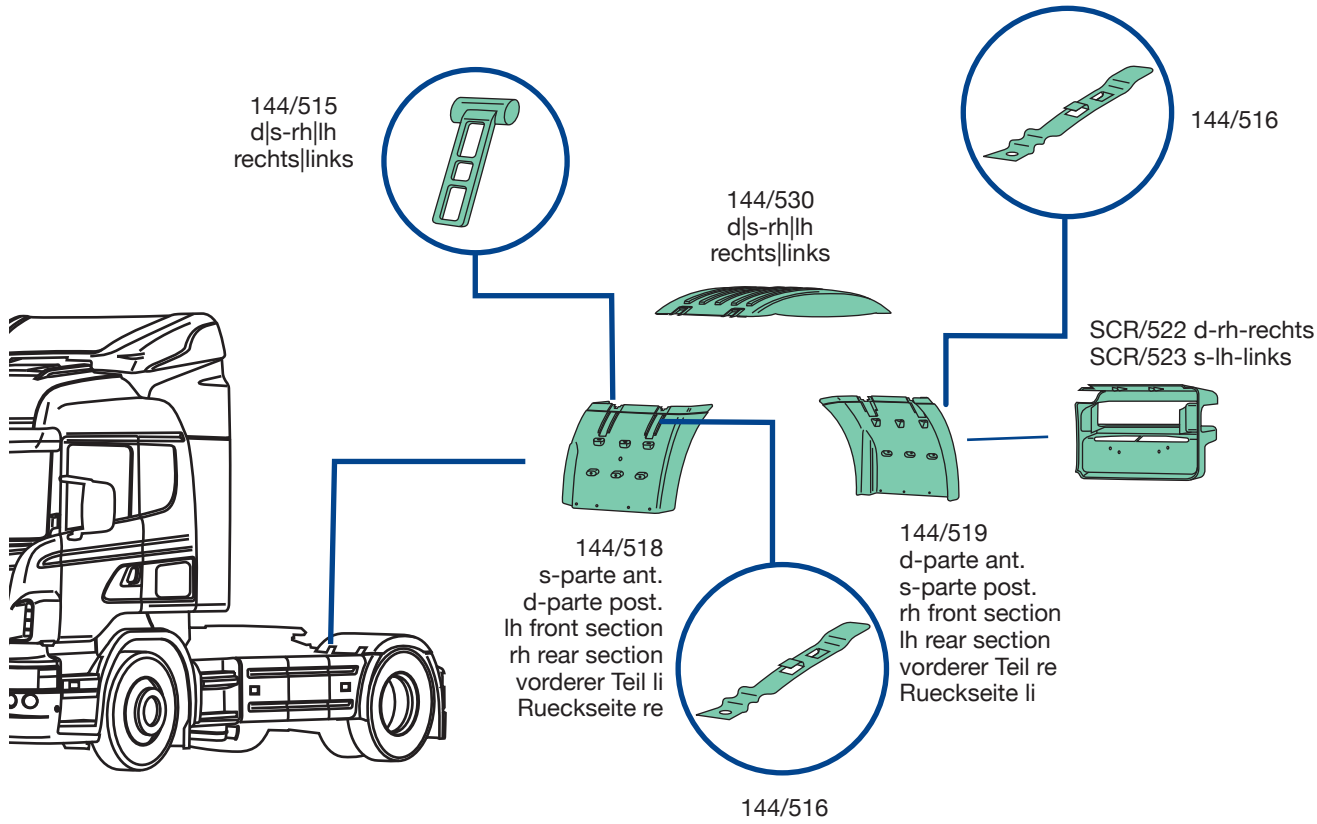

144/515
O.E.M. 1383858



144/516
O.E.M. 2056867



SCR/522
O.E.M. 202662
SCR/523
O.E.M. 1362708

144/530
 O.E.M. 1357602
 d|s-rh|lh-rechts|links
 grigio, piatta, senza cinghietti
 grey, flat, without stretchers
 grau, flach, ohne Spanngummi

144/519
 O.E.M. 1357599
 d|s-rh|lh-rechts|links
 grigio, senza anti-spray
 grey, without anti-spray
 grau, ohne Spritzschutz

144/518
 O.E.M. 1357600
 d|s-rh|lh-rechts|links
 grigio
 grey
 grau



applicabile a | suitable to | verwendbar für:

SCANIA R 2010 CG-CR

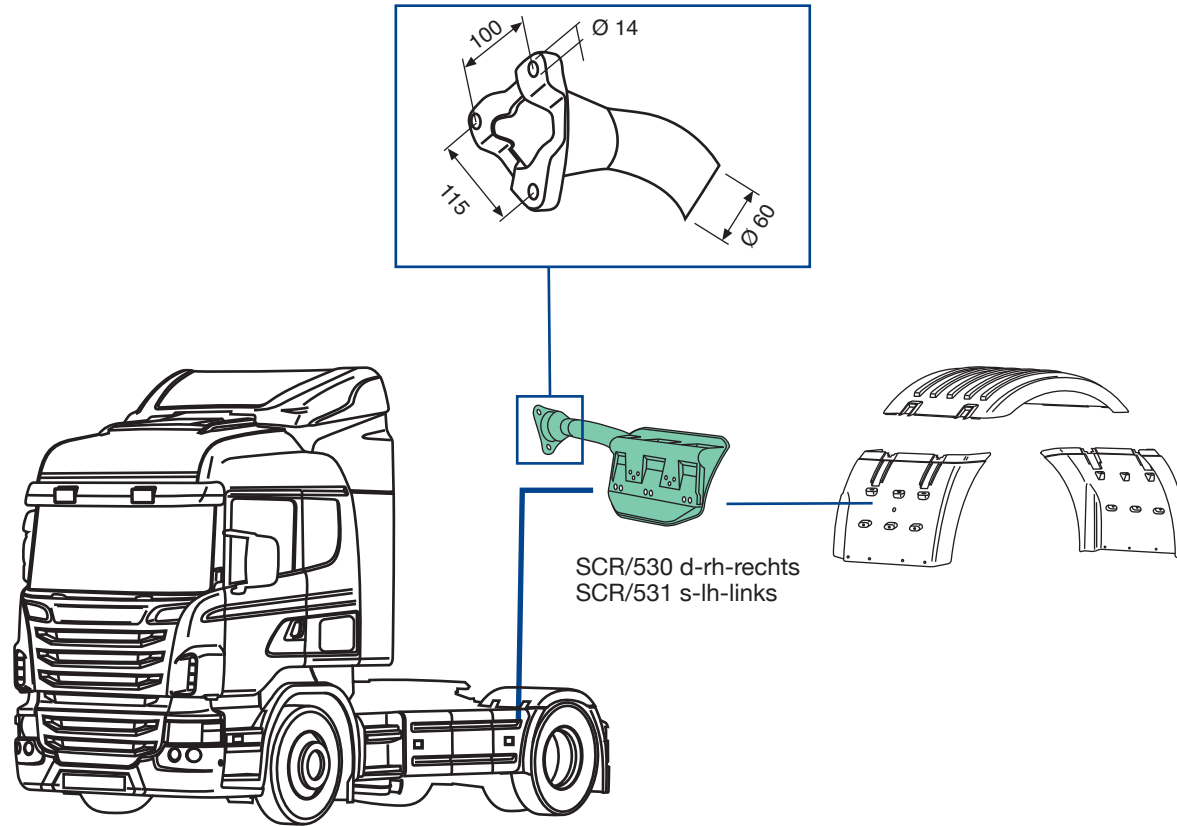



SCR/530
O.E.M. 2054582
anteriore destro
front right
vorne rechts

SCR/531
O.E.M. 2054581
anteriore sinistro
front left
vorne links

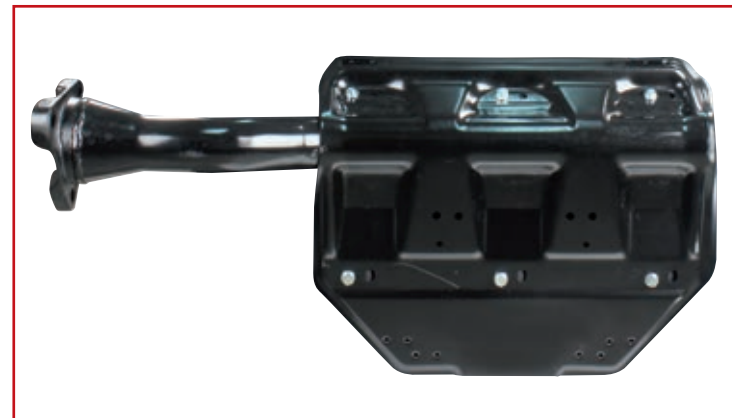
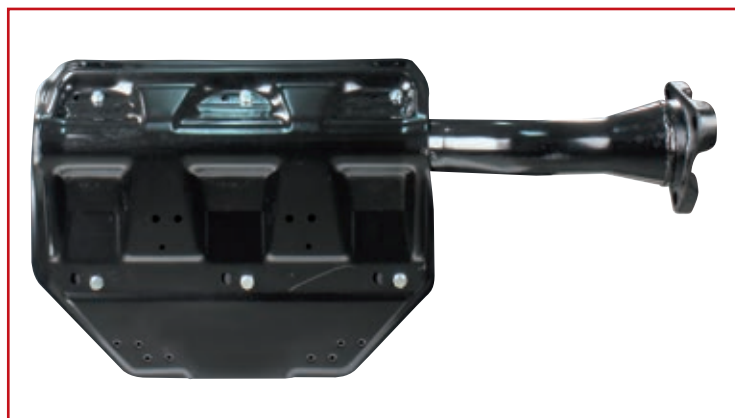

applicabile a | suitable to | verwendbar für:

SCANIA R 2010 CG-CR

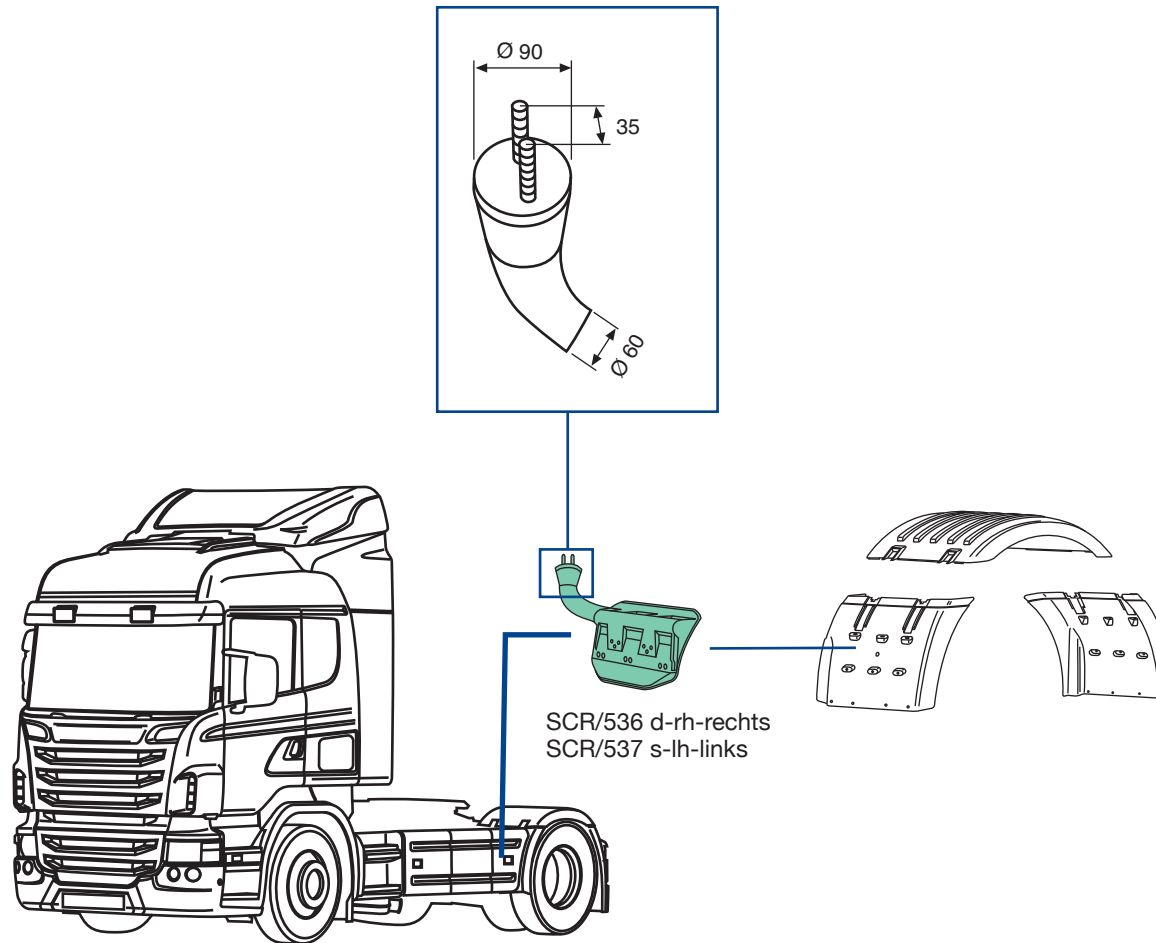



SCR/536
O.E.M. 1457920
anteriore destro
front right
vorne rechts

SCR/537
O.E.M. 1457919
anteriore sinistro
front left
vorne links

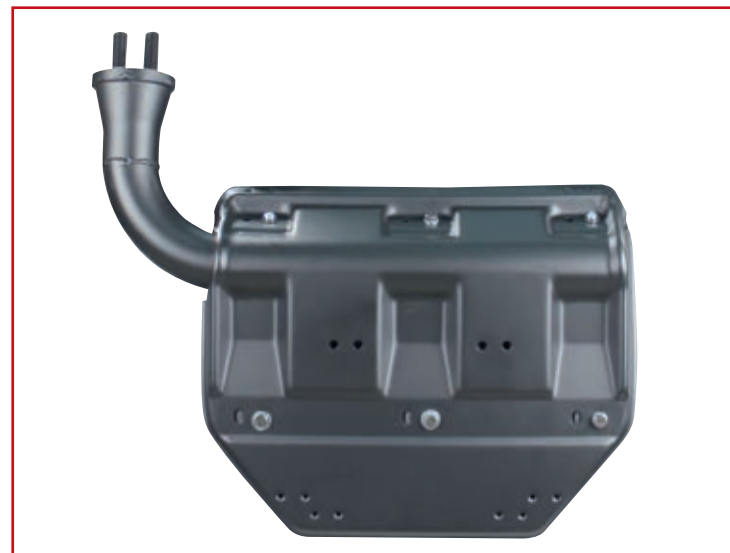

applicabile a | suitable to | verwendbar für:

SCANIA R 2010 CG-CR

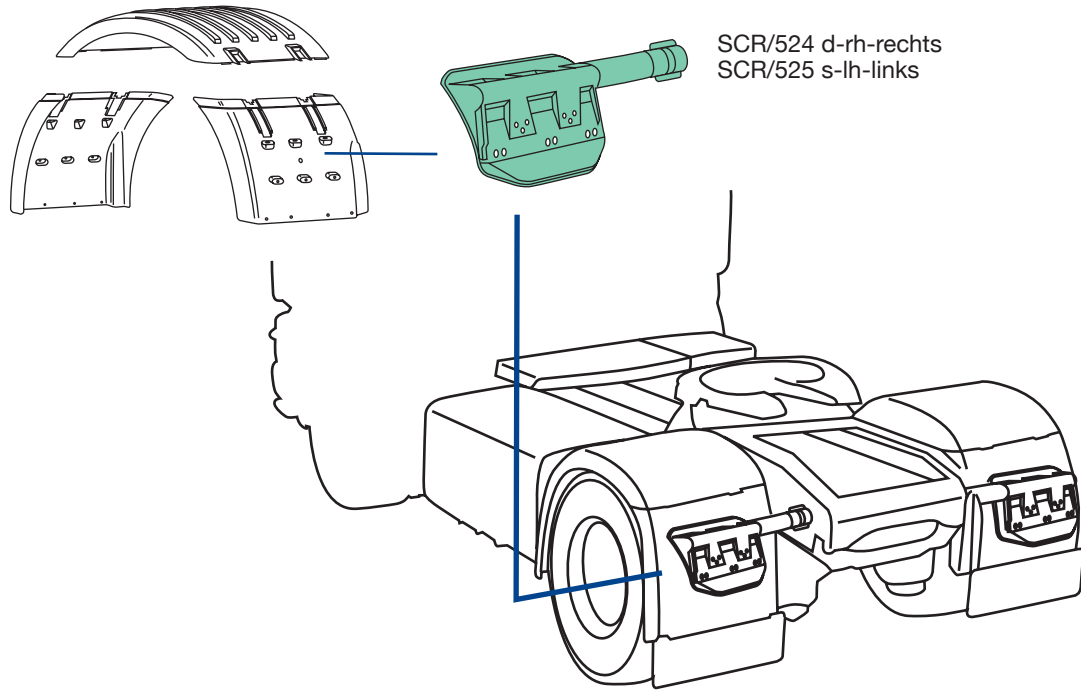



SCR/525
O.E.M. 2054589
posteriore sinistro
rear left
hinten links

SCR/524
O.E.M. 2054590
posteriore destro
rear right
hinten rechts



applicabile a | suitable to | verwendbar für:

SCANIA R 2010 CG-CR

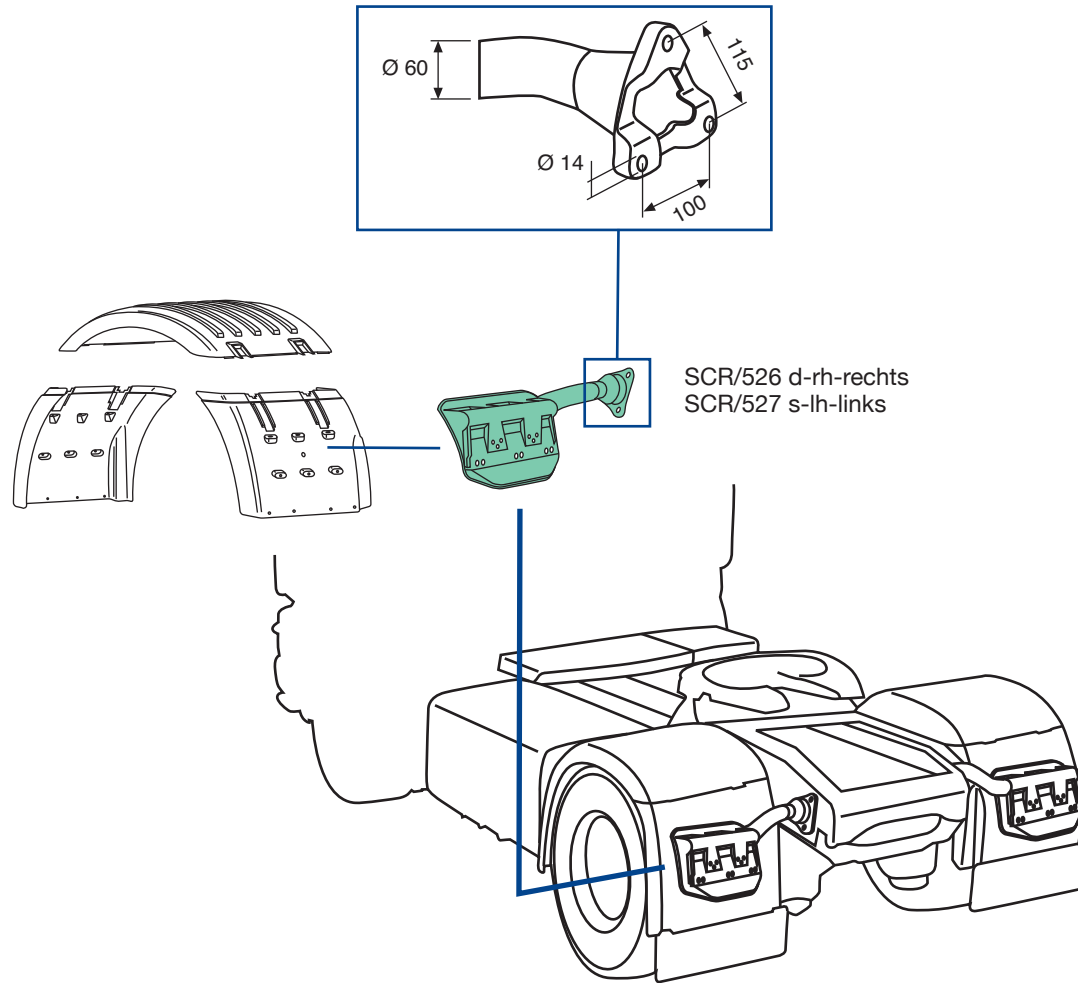



SCR/527
O.E.M. 2054579
posteriore sinistro
rear left
hinten links

SCR/526
O.E.M. 2054580
posteriore destro
rear right
hinten rechts



applicabile a | suitable to | verwendbar für:

SCANIA R 2010 CG-CR

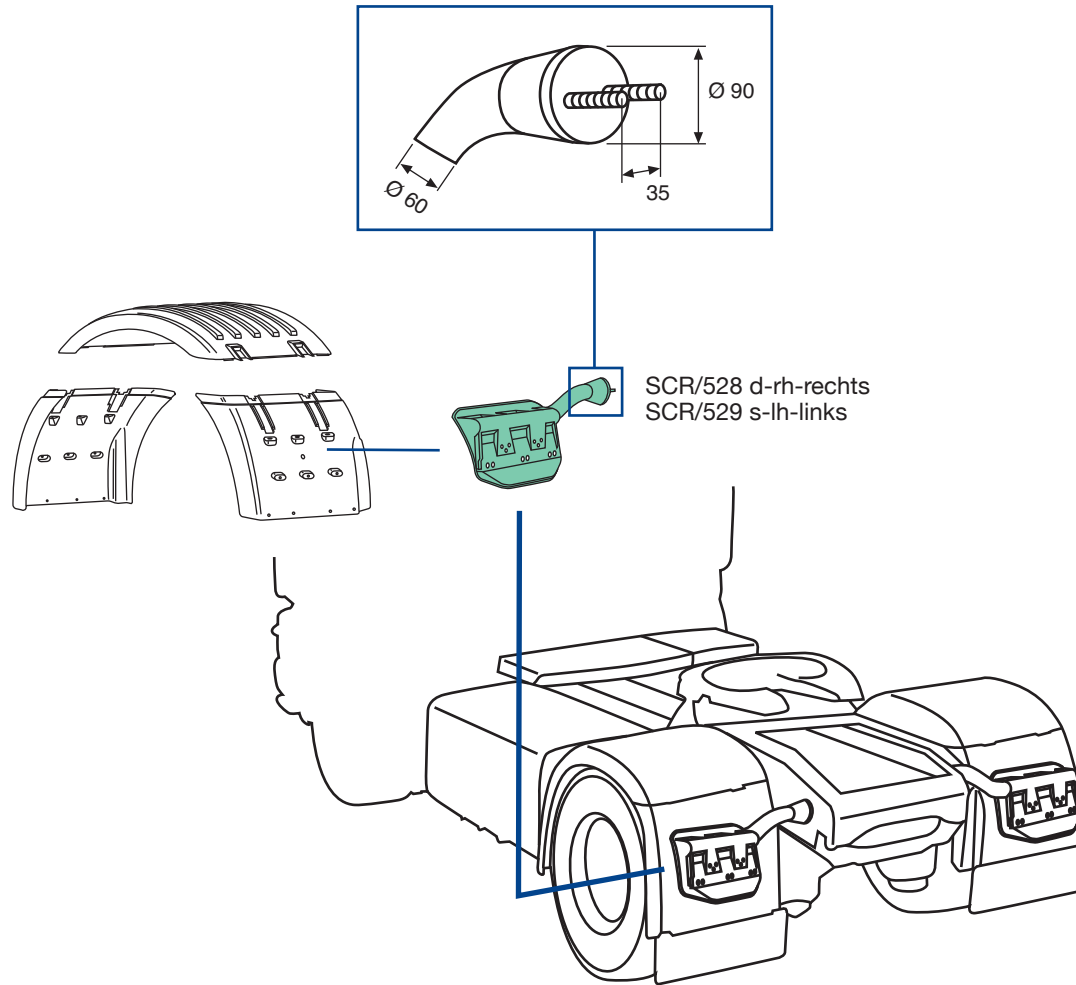



SCR/529
O.E.M. 2054603
posteriore sinistro
rear left
hinten links

SCR/528
O.E.M. 2054604
posteriore destro
rear right
hinten rechts



applicabile a | suitable to | verwendbar für:

SCANIA R 2010 CG-CR

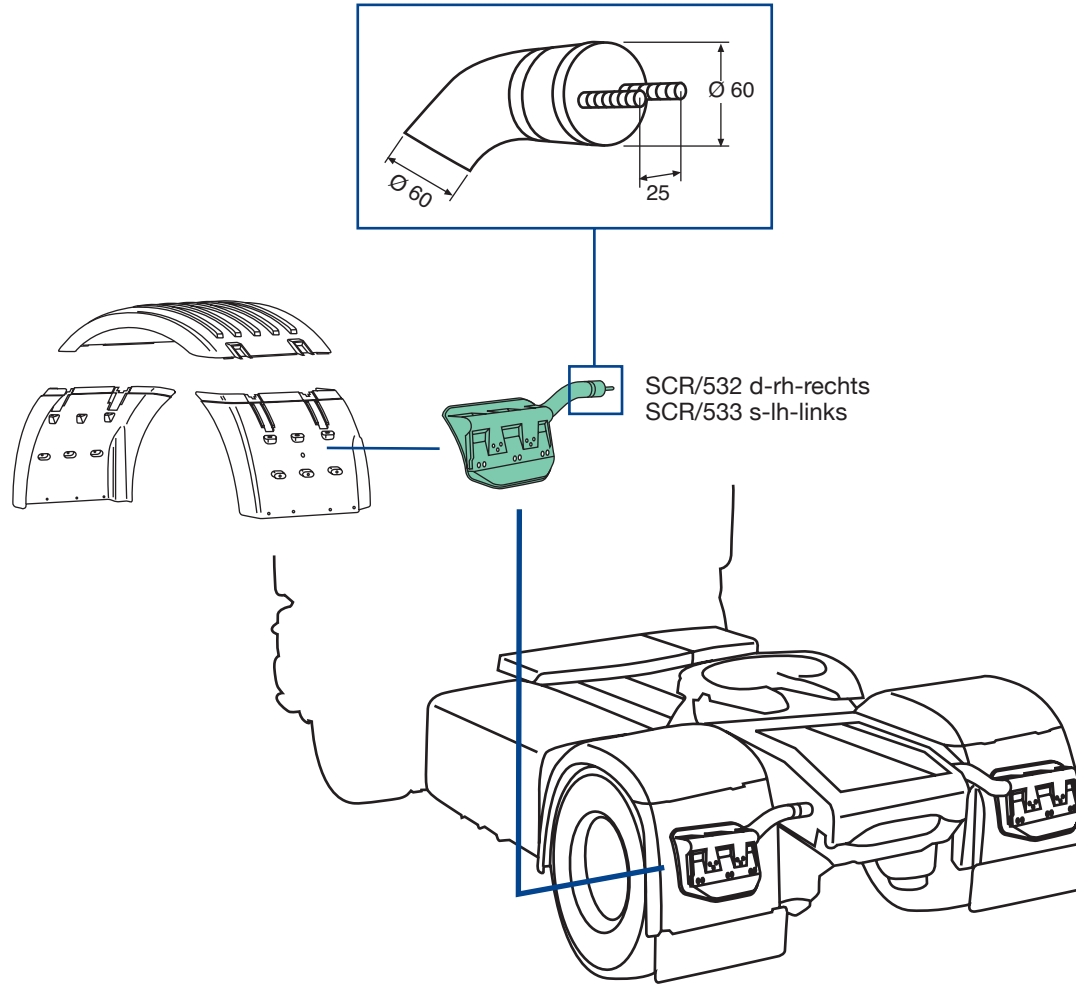



SCR/533
O.E.M. 1457929
posteriore sinistro
rear left
hinten links

SCR/532
O.E.M. 1457930
posteriore destro
rear right
hinten rechts



applicabile a | suitable to | verwendbar für:

SCANIA R 2010 CG-CR

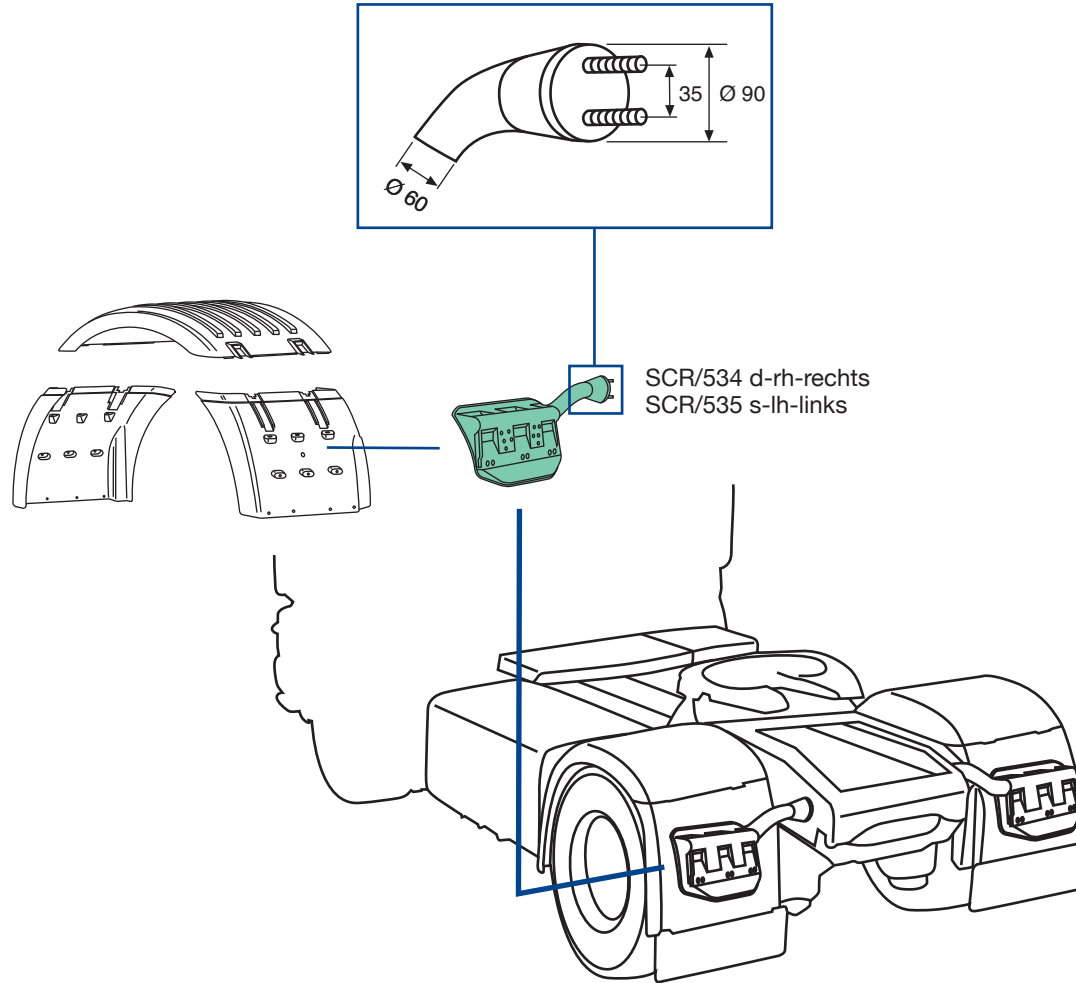



SCR/535
O.E.M. 2054601
posteriore sinistro
rear left
hinten links

SCR/534
O.E.M. 2054602
posteriore destro
rear right
hinten rechts



applicabile a | suitable to | verwendbar für:

SCANIA R 2010 CG-CR

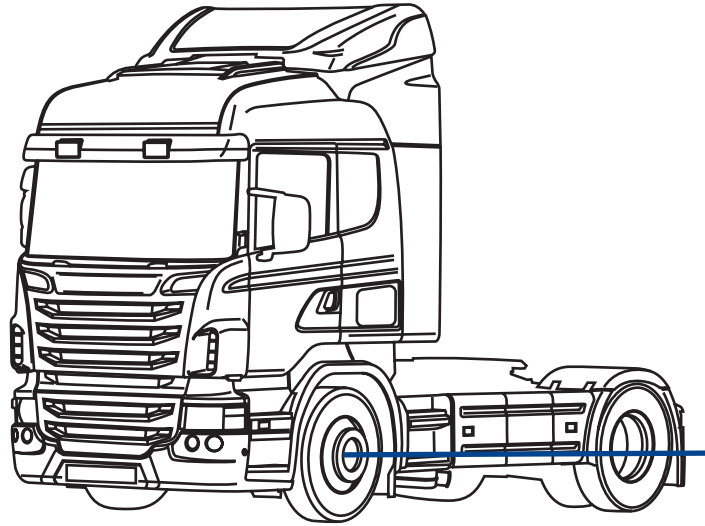

930/033

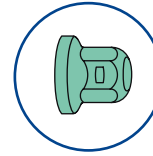

930/100
d-rh-rechts
930/101
s-lh-links

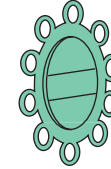
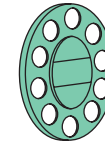

930/001
d-rh-rechts
930/002
s-lh-links

930/200
d|s-rh|lh
rechts|links



930/033
O.E.M. -



930/001
O.E.M. -
930/002
O.E.M. -



930/100
O.E.M. -
930/101
O.E.M. -



930/200
O.E.M. -

SCANIA R 2010 CG-CR

930/033 - Tappo copri Bullone - Bolt cover - Radmutterkappen

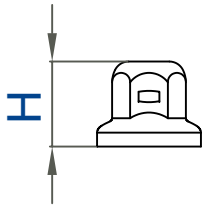

H	45 mm
Per bulloni \varnothing - bolt \varnothing	33 mm
Schlüsselweite \varnothing	
Colore	cromato-chrome-verchromt
Colours-Farbe	
Materiale-Material	acciaio inox-stainless steel Edelstahl
Kg	0,025

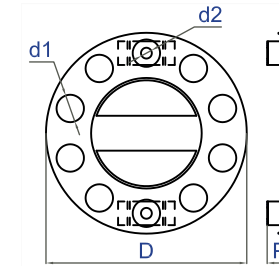

930/001 d-rh-rechts - 930/002 s-lh-links

D \varnothing 425 mm	P 50 mm
d1 nr. 10	d1 \varnothing 58 mm
d2 nr. 2	d2 \varnothing 23 mm
Ventilata	si-yes-Ja
Ventilated-Belüftet	
Colore	cromato e nero-chrome and black
Colours-Farbe	verchromt und schwarz
Materiale-Material	acciaio inox e plastica stainless steel and plastic Edelstahl und Kunststoff
Kg	1,230

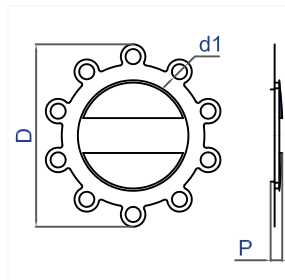

930/100 d-rh-rechts - 930/101 s-lh-links

D \varnothing 387 mm	P 30 mm
d1 nr. 10	d1 \varnothing 32 mm
Ventilata	si-yes-Ja
Ventilated-Belüftet	
Colore	cromato e nero-chrome and black
Colours-Farbe	verchromt und schwarz
Materiale-Material	acciaio inox e plastica stainless steel and plastic Edelstahl und Kunststoff
Kg	0,655

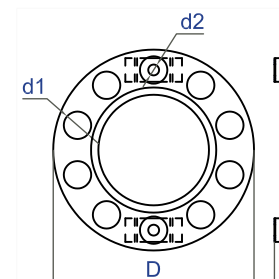

930/200 d|s-rh|lh-rechts|links

D \varnothing 425 mm	P 40 mm
d1 nr. 10	d1 \varnothing 58 mm
d2 nr. 2	d2 \varnothing 23 mm
Ventilata	no-nein
Ventilated-Belüftet	
Colore	cromato-chrome-verchromt
Colours-Farbe	
Materiale-Material	acciaio inox-stainless steel Edelstahl
Kg	1,155

applicabile a | suitable to | verwendbar für:

SCANIA R 2010 CG-CR

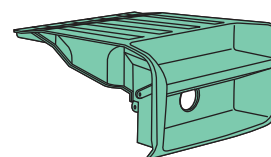
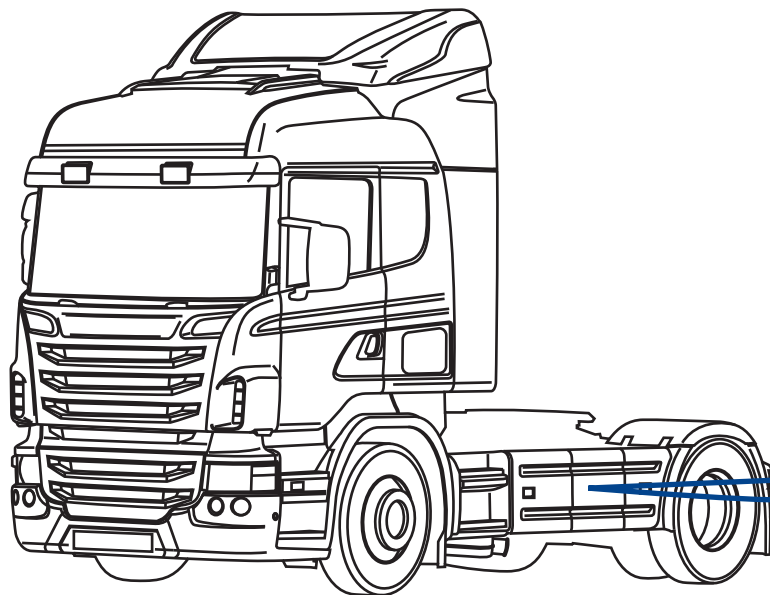

SCR/619

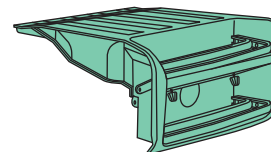

SCR/620(*)
con - with - mit:
1425051 (2 pz.-pcs.-st.) +
1425052 (2 pz.-pcs.-st.) +
1362691



SCR/619
O.E.M. 2093721



SCR/620
O.E.M. 2093720



applicabile a | suitable to | verwendbar für

125

SCP
SCANIA R CP

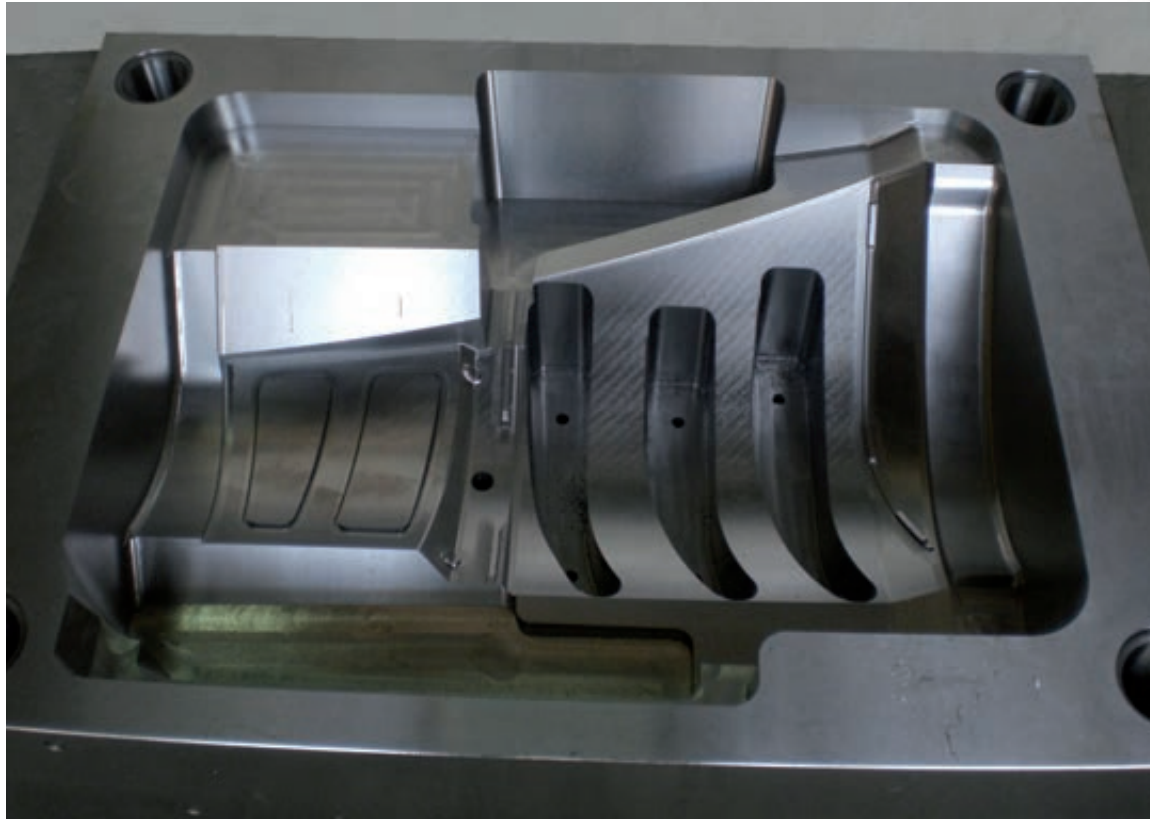

- IT Stampo in acciaio temprato per la produzione di un deviatore aria
EN Hardened steel mold for production for air buffle
DE Gehärtete Stahlform für die Produktion eines Luftabweisers

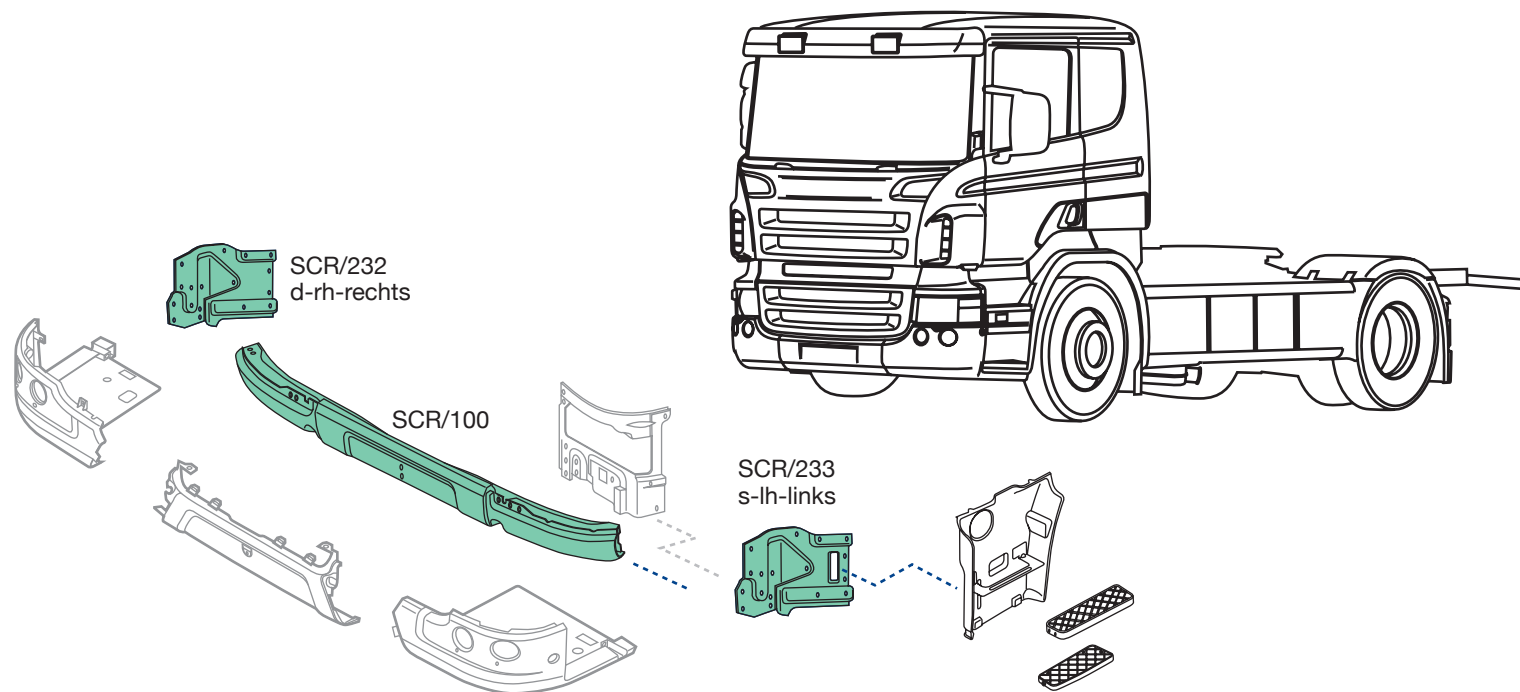

SCR/100
O.E.M. 1763296

SCR/232
O.E.M. 1431585

SCR/233
O.E.M. 1431584

applicabile a | suitable to | verwendbar für:

SCANIA R CP

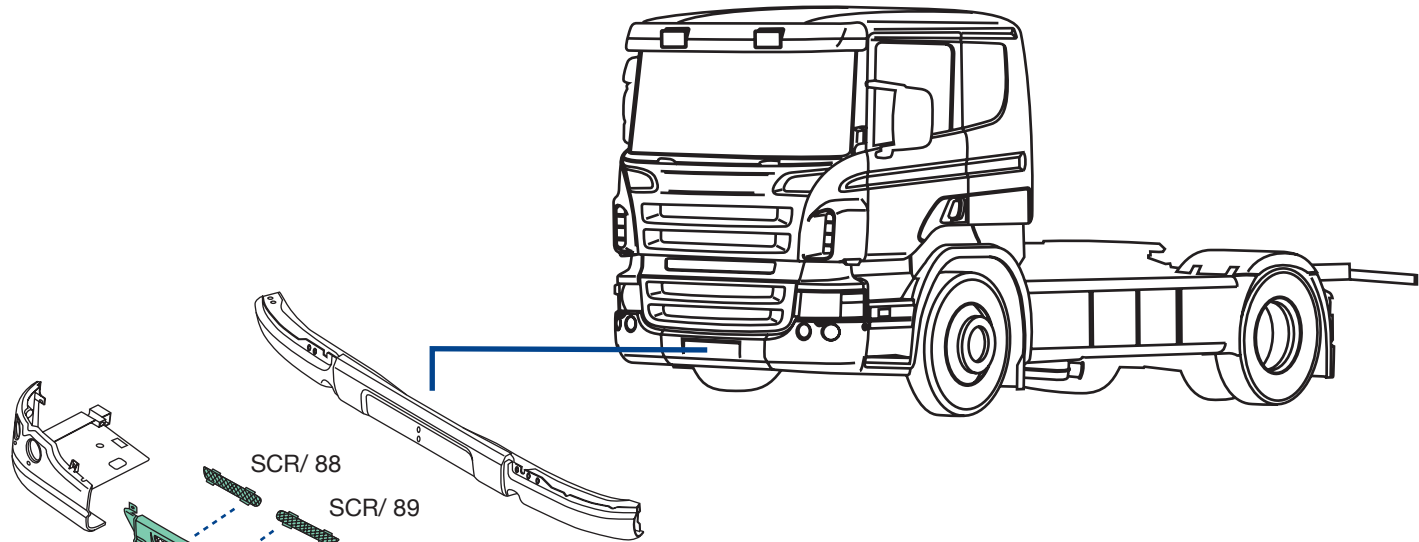

SCR/ 90(°)
KIT - Satz
composto da:
composed by:
bestehend aus:
SCR/ 88 d-rh-rechts
SCR/ 89 s-lh-links
1539397 (pz.-pcs-st. 8)
1431924 (pz.-pcs-st. 1)

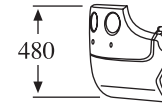

per paraurti basso
for low bumper
für niedrigen Stoßfänger



SCR/ 88
O.E.M. 1495578
SCR/ 89
O.E.M. 1495577



SCR/ 90
O.E.M. 1504131

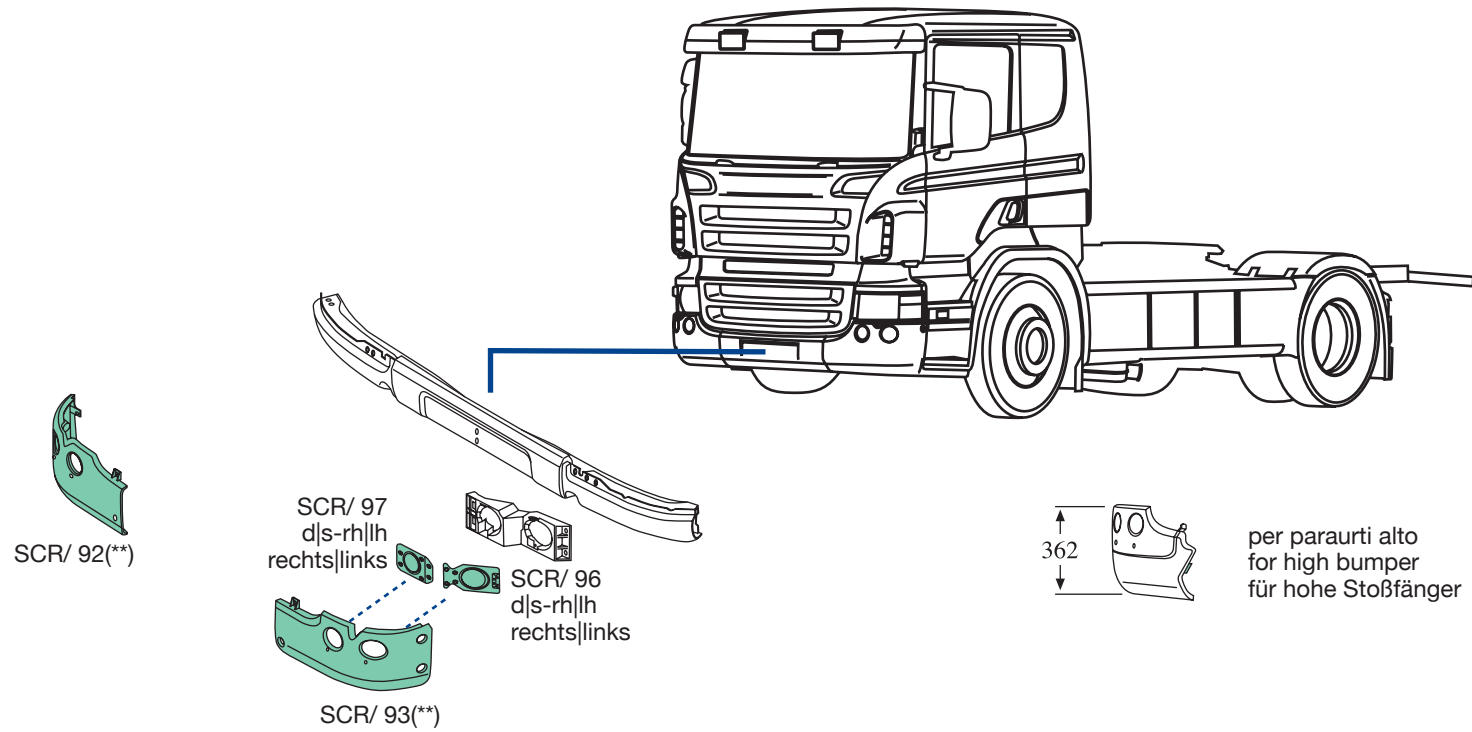

SCR/ 92
O.E.M. 1439789
SCR/ 93
O.E.M. 1439788



SCR/ 96
O.E.M. 1523509



SCR/ 97
O.E.M. 1523508

SCANIA R CP

(*) Larghezza telaio mm 1020 - chassis width 1020 mm - Chassis: Breite 1020 Millimeter (mm)

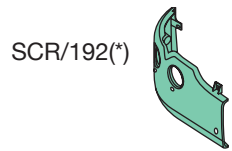

SCR/192(*)

SCR/ 98
d-rh-rechts
SCR/ 99
s-lh-links
con cerniera
with hinge
mit Scharnier
(1493381+1509091)

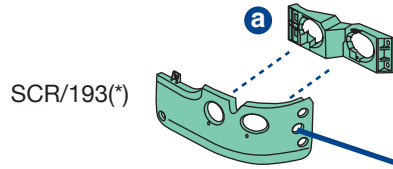

SCR/193(*)

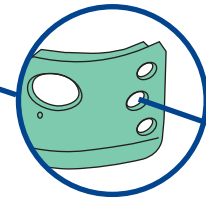
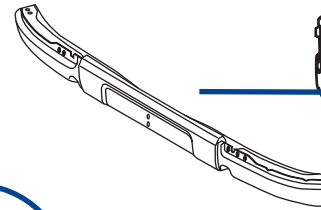

SCR/190
d|s-rh|lh
rechts|links

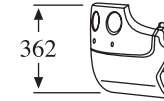

362

per paraurti alto
for high bumper
für hohe Stoßfänger



SCR/ 98
O.E.M. 1786693
SCR/ 99
O.E.M. 1786692

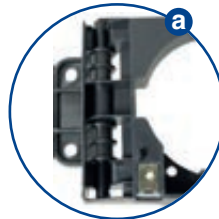

SCR/190
O.E.M. 1923152



SCR/192
O.E.M. 1853194
SCR/193
O.E.M. 1853193

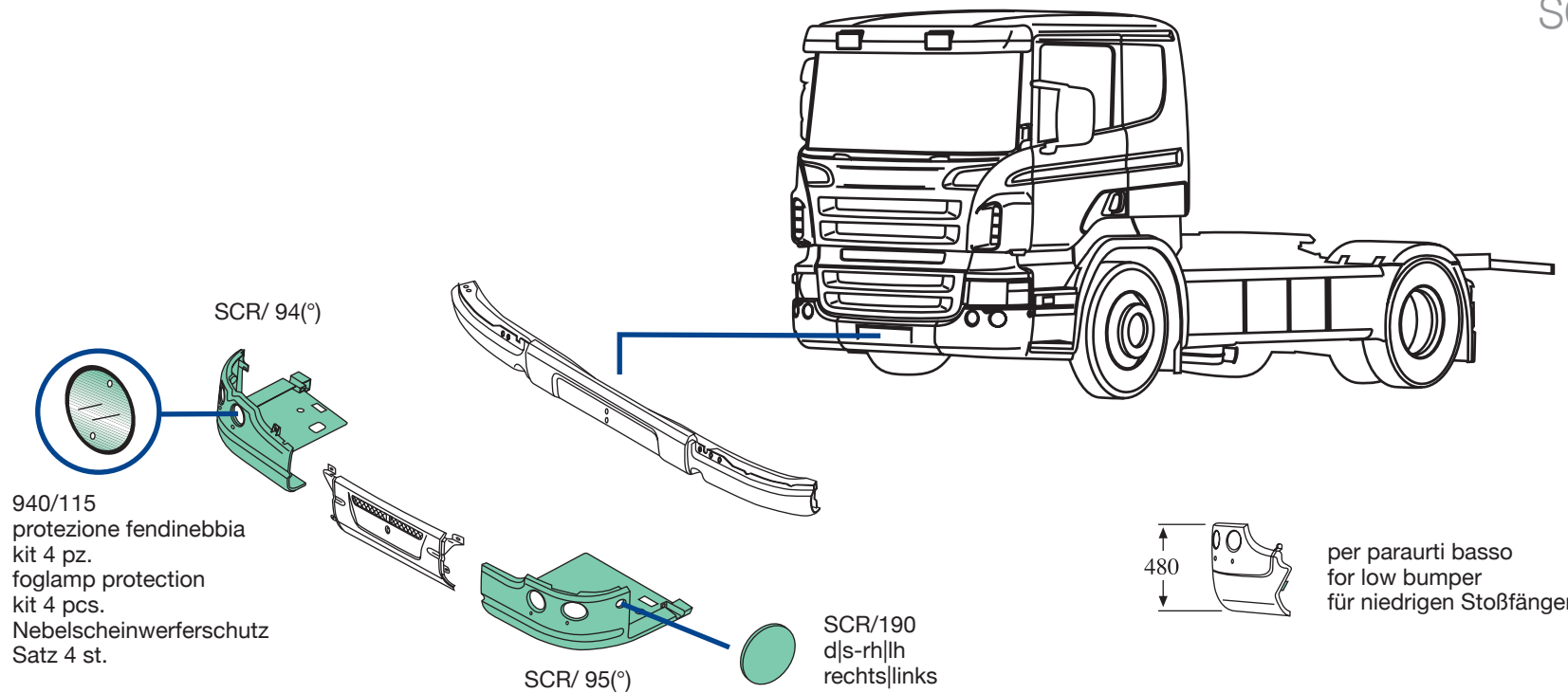

940/115
O.E.M. -



SCR/ 94
O.E.M. 1853347
SCR/ 95
O.E.M. 1853346



SCR/190
O.E.M. 1923152

applicabile a | suitable to | verwendbar für:

SCANIA R CP

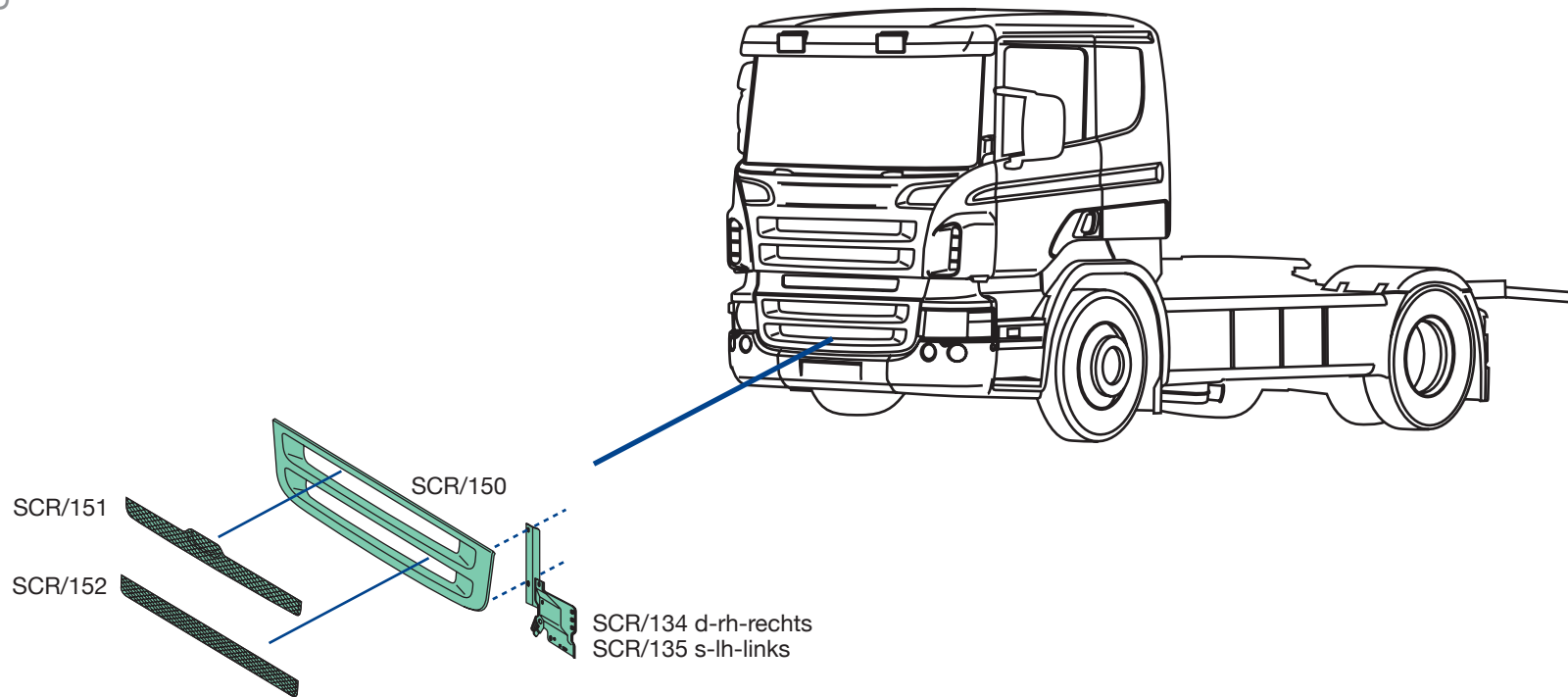

SCR/134
O.E.M. 1742265
SCR/135
O.E.M. 1742264



SCR/150
O.E.M. 1536807



SCR/151
O.E.M. 1459141



SCR/152
O.E.M. 1459142

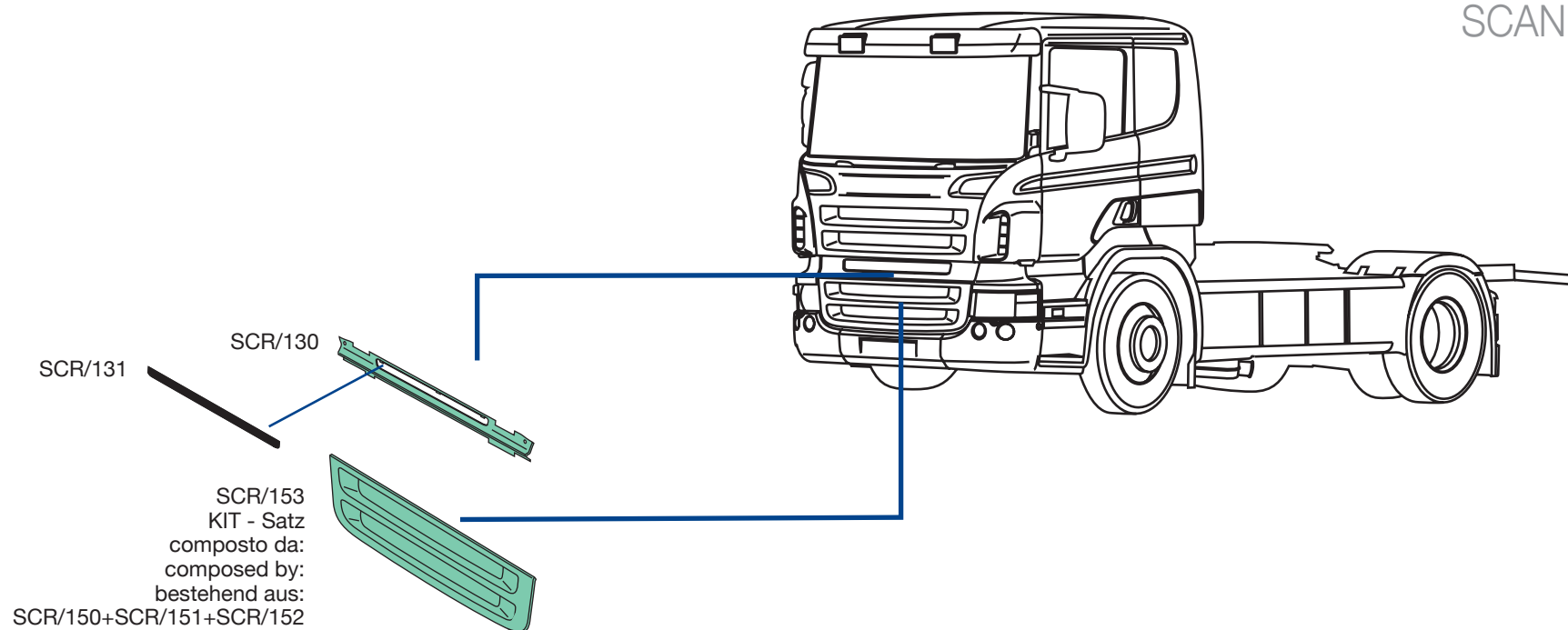

SCR/153
O.E.M. -



SCR/130
O.E.M. 1748086



SCR/131
O.E.M. 1459146

applicabile a | suitable to | verwendbar für:

SCANIA R CP

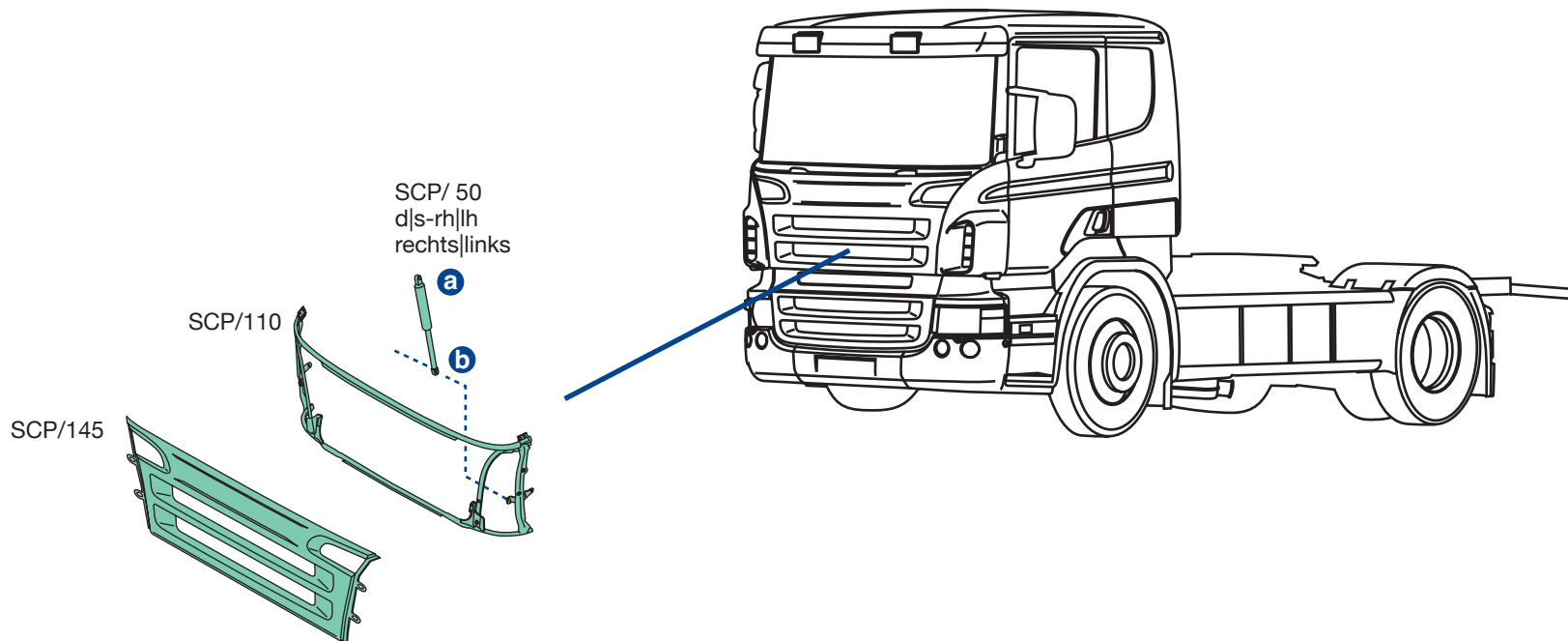

SCP/ 50
O.E.M. 2031866



SCP/110
O.E.M. 2008861



SCP/145
O.E.M. 1543607

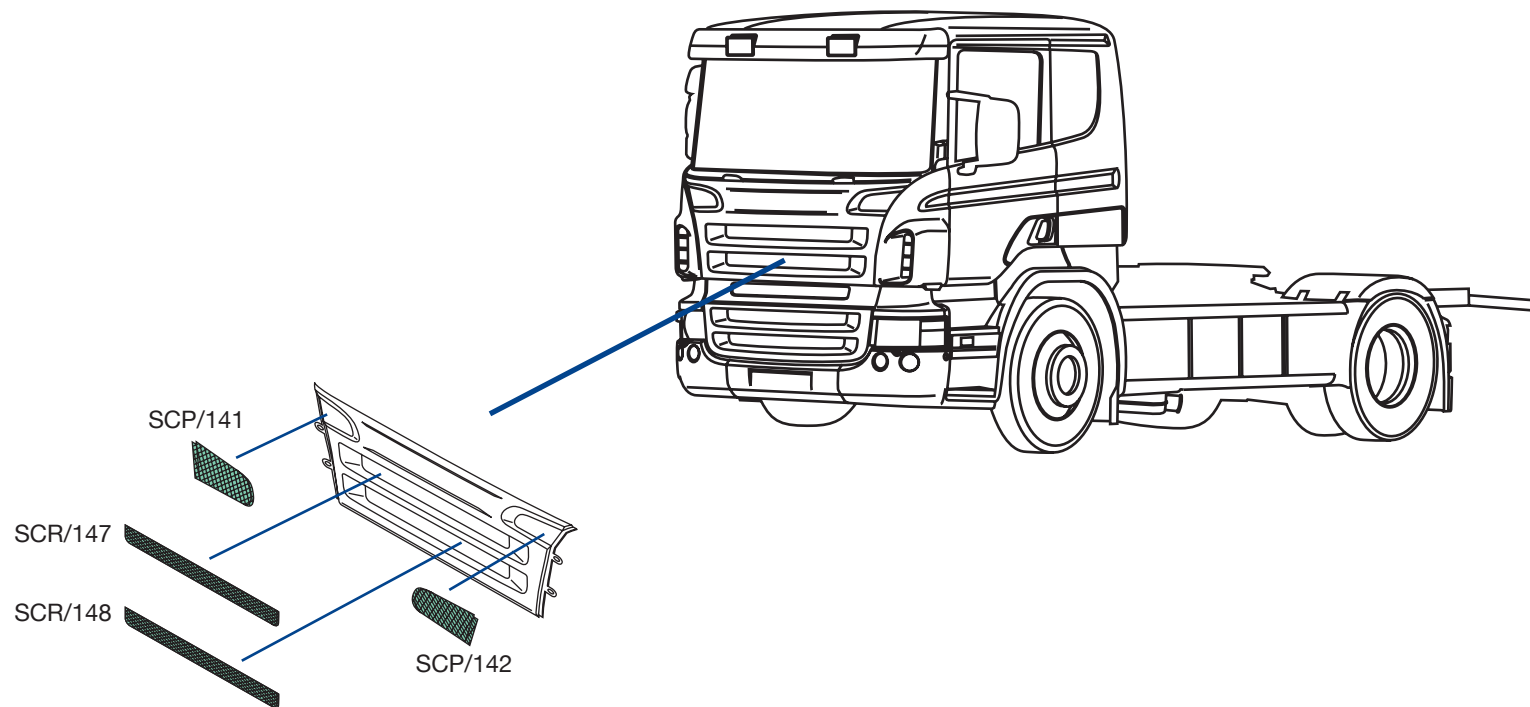

SCP/141
O.E.M. 1466035
SCP/142
O.E.M. 1466034



SCR/147
O.E.M. 1880737

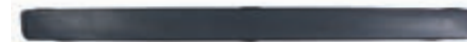

SCR/148
O.E.M. 1459135

applicabile a | suitable to | verwendbar für:

SCANIA R CP R CP

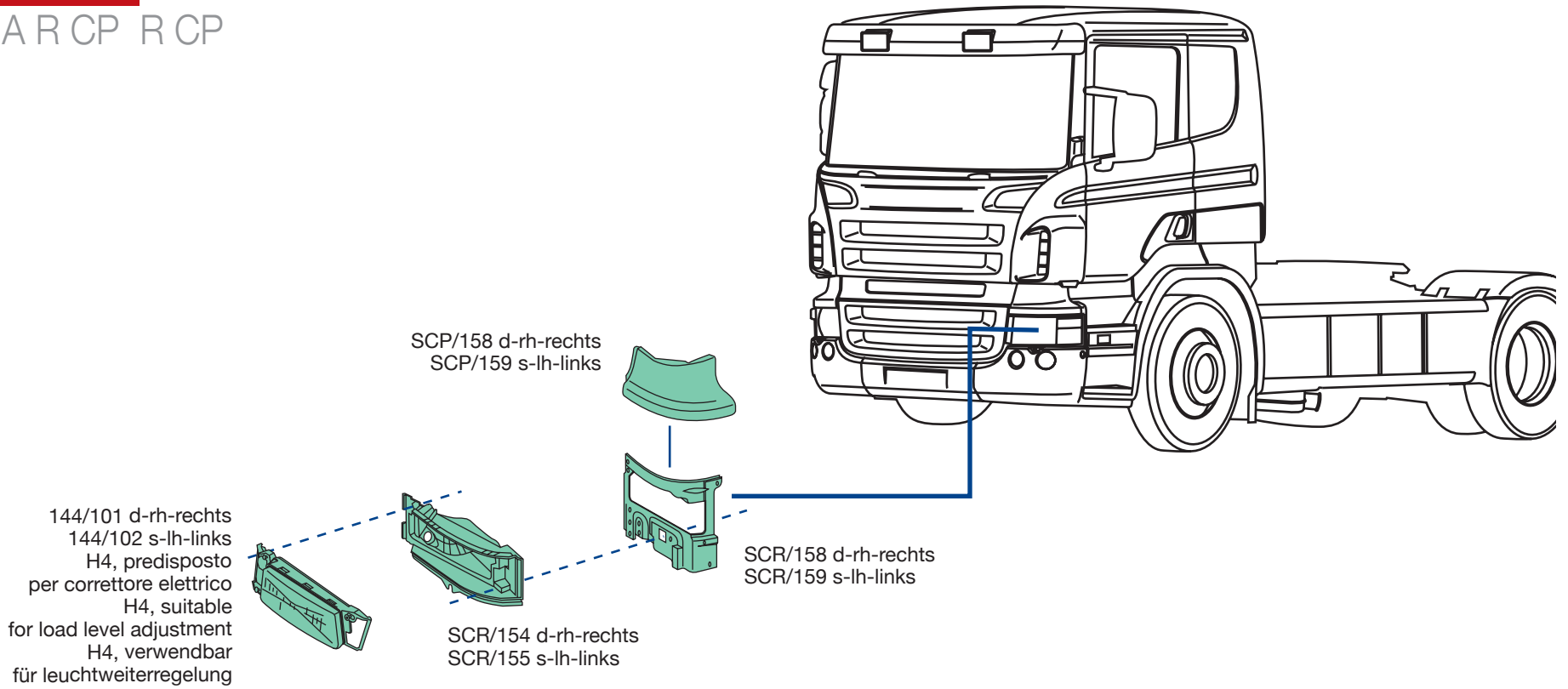

144/101
O.E.M. 1732510
144/102
O.E.M. 1732509



SCP/158
O.E.M. 1438564
SCP/159
O.E.M. 2124011



SCR/154
O.E.M. 1936675
SCR/155
O.E.M. 1936674



SCR/158
O.E.M. 1727992
SCR/159
O.E.M. 1727991

SCP/ 2 d-rh-rechts
SCP/ 3 s-lh-links
lastrata, con cerniere
paneled with hinges
rohbautür, mit Scharnier

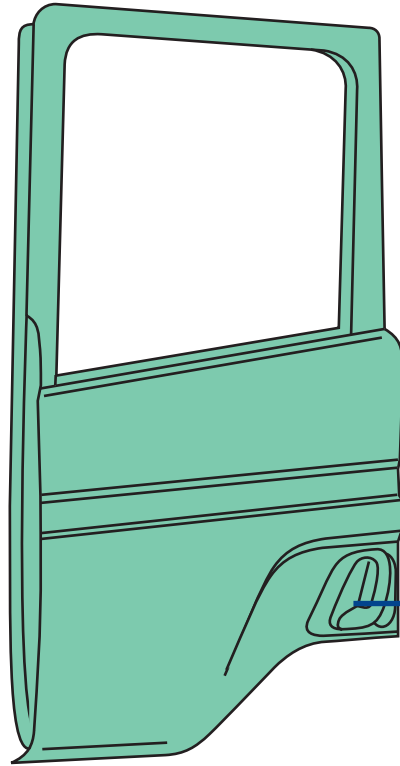

144/194 d-rh-rechts
144/195 s-lh-links

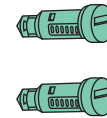
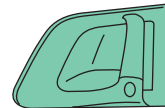

144/196
d|s-rh|lh
rechts|links

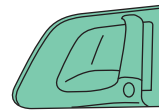

SCR/194 d-rh-rechts
SCR/195 s-lh-links



SCP/ 2
O.E.M. 1476533
SCP/ 3
O.E.M. 1476532



144/194
O.E.M. 2145648
144/195
O.E.M. 2145647



144/196
O.E.M. 1485072



SCR/194
O.E.M. -
SCR/195
O.E.M. -

SCANIA R CP

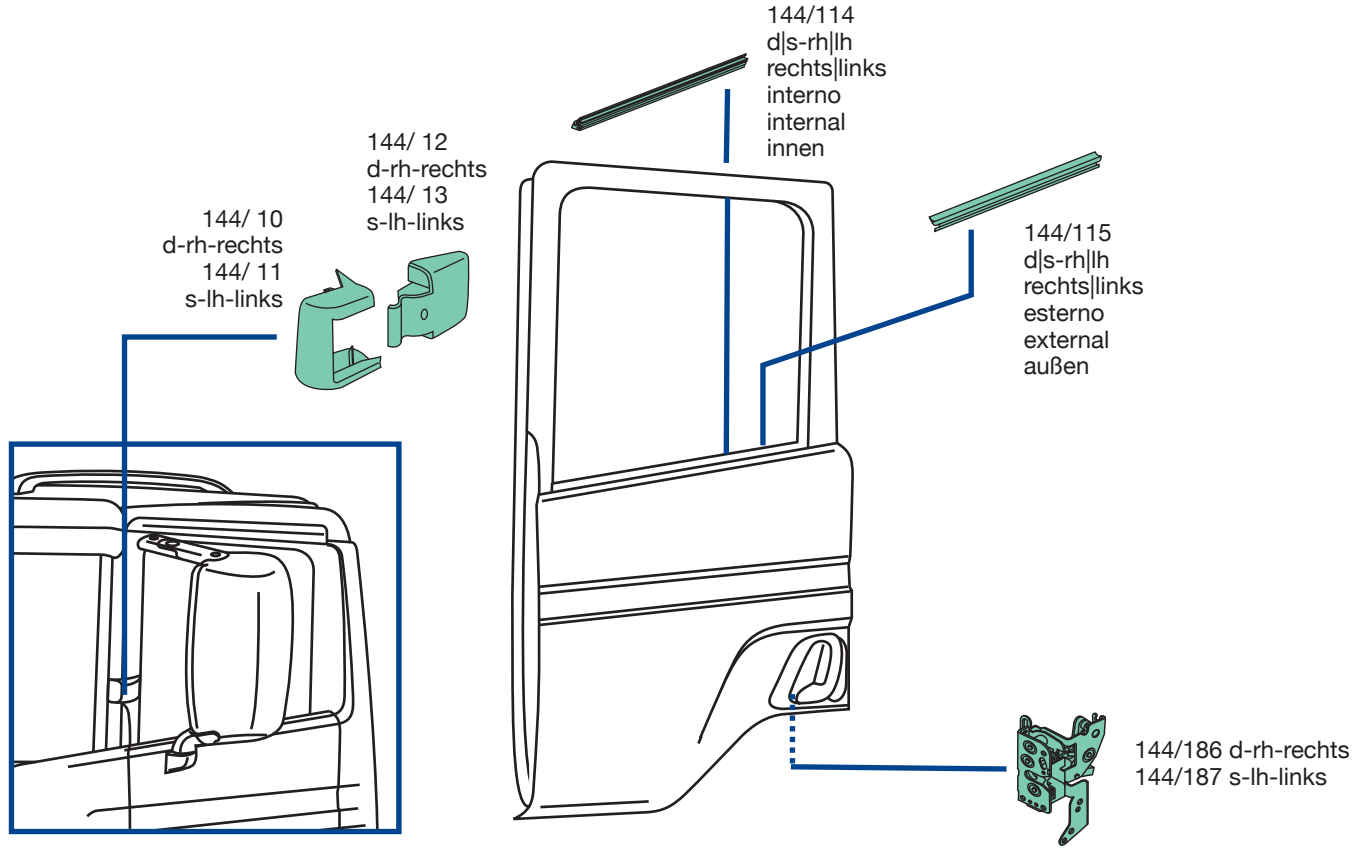

144/ 10
O.E.M. 1472832
144/ 11
O.E.M. 1472833



144/ 12
O.E.M. 1346940
144/ 13
O.E.M. 1346939



144/114
O.E.M. 1865520

144/115
O.E.M. 1865517



144/186
O.E.M. 1867655
144/187
O.E.M. 1867654

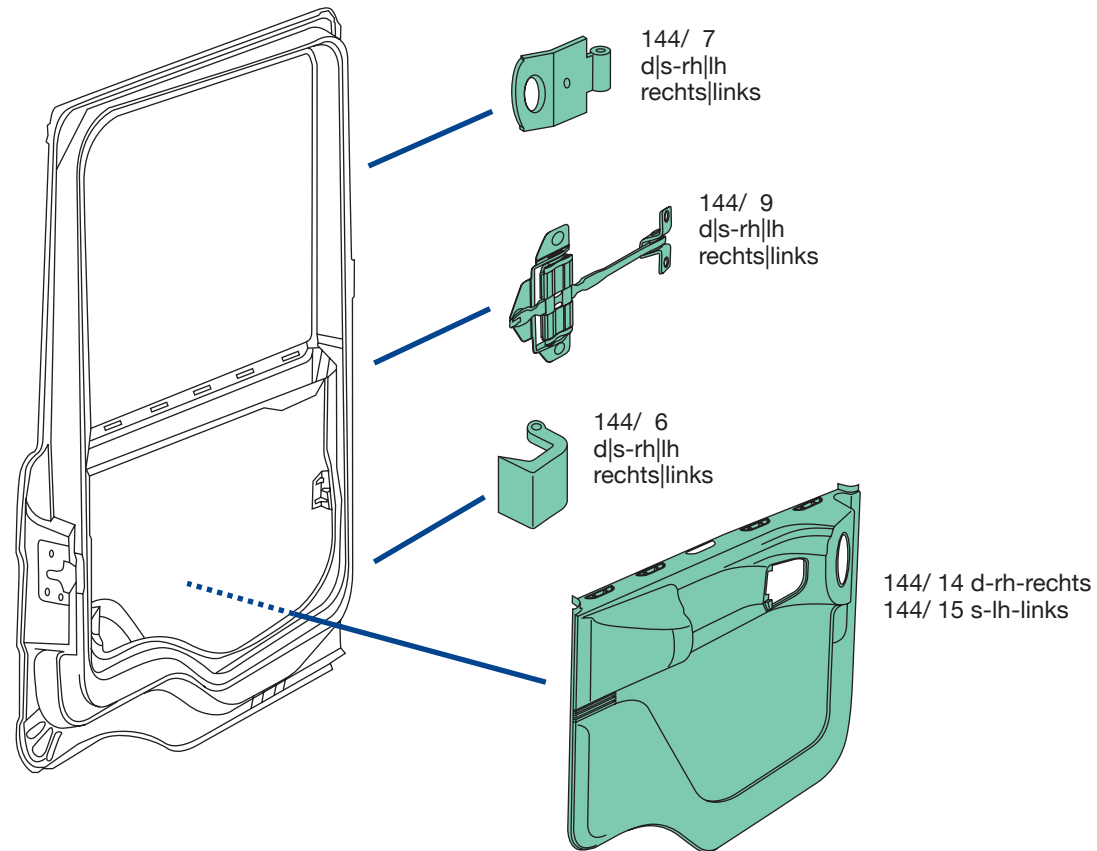

144/ 6
O.E.M. 1426925



144/ 7
O.E.M. 1422292



144/ 9
O.E.M. 1930649



144/ 14
O.E.M. 1346164
144/ 15
O.E.M. 1346163

applicabile a | suitable to | verwendbar für:

SCANIA R CP



144/503



E4 024107

200x432 mm



applicabilità:
applicable to:
Verwendbar für

SCANIA SERIE 4 1996→2004
SCANIA SERIE R/P/T 2004→

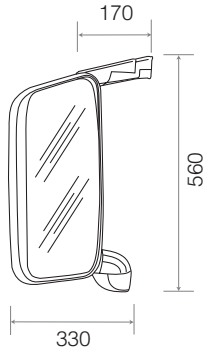

COVIND



IV

a

-

-

b

144/501

1765985



E4 024107

200x432 mm



d

-

-

f

144/512

1346380



applicabile a | suitable to | verwendbar für:

SCANIA R CP



144/505

2425815
(1723518)



|| E4 024107
200x432 mm

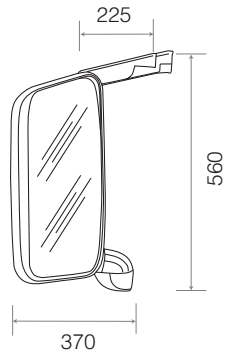

applicabilità:
applicable to:
Verwendbar für

SCANIA SERIE 4 1996→2004
SCANIA SERIE R/P/T 2004→



a

- -

b

144/501

1765985

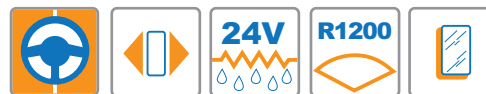

E4 024107

200x432 mm



d

- -

f

144/512

1346380



applicabile a | suitable to | verwendbar für:

SCANIA R CP



144/506

2425816
(1723519)



E4 024107

200x432 mm



E4 024108

160x184 mm



applicabilità:
applicable to:
Verwendbar für

SCANIA SERIE 4 1996→2004
SCANIA SERIE R/P/T 2004→

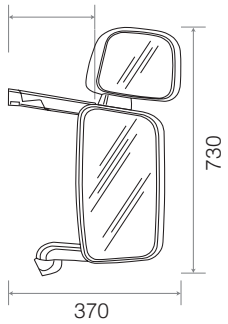

COVIND

144/510

IV

1765808



260x348 mm

a	-	-							
b	144/501 II	1765985							E4 024107 200x432 mm
c	144/502 IV	1767265							E4 024108 160x184 mm
d	-	-							
e	-	-							
f	144/512	1346380							

applicabile a | suitable to | verwendbar für:

SCANIA R CP



144/507

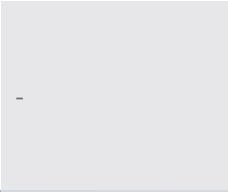

II (E4) 024107
200x432 mm



IV (E4) 024108
184x160 mm

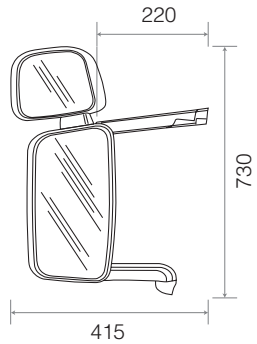
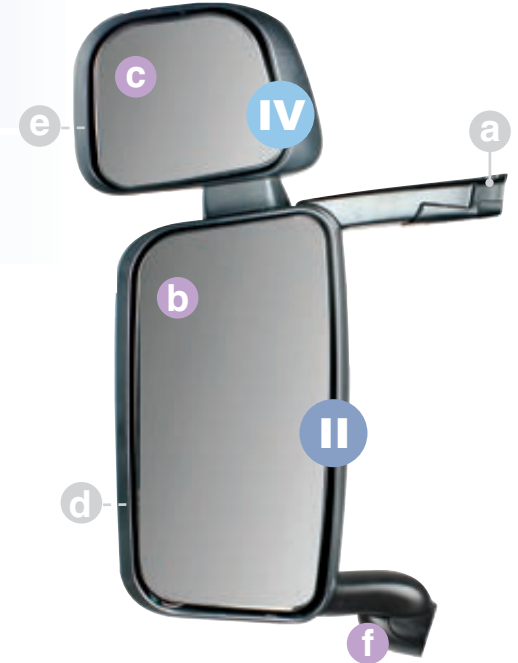

applicabilità:
applicable to:
Verwendbar für

SCANIA SERIE 4 1996→2004
SCANIA SERIE R/P/T 2004→

COVIND

144/511

IV

1765809



260x348 mm

a	-	-								
b	144/501	1765985							E4 024107	200x432 mm
	II									
c	144/502	1767265							E4 024108	184x160 mm
	IV									
d	-	-								
e	-	-								
f	144/512	1346380								

applicabile a | suitable to | verwendbar für:

SCANIA R CP



144/508



II

E4 024107

200x432 mm



IV

E4 024108

184x160 mm



applicabilità:
applicable to:
Verwendbar für

SCANIA SERIE 4 1996→2004
SCANIA SERIE R/P/T 2004→

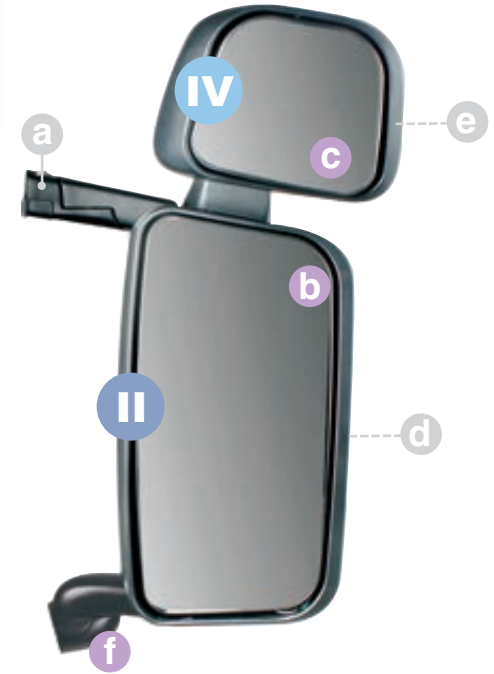
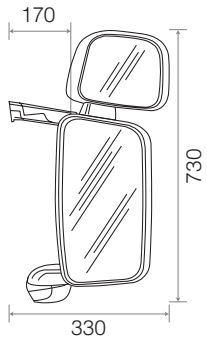

COVIND

144/510

1765808



260x348 mm

IV

a	-	-								
b	144/501	1765985							E4 024107	200x432 mm
	II									
c	144/502	1767265							E4 024108	184x160 mm
	IV									
d	-	-								
e	-	-								
f	144/512	1346380								

applicabile a | suitable to | verwendbar für:

SCANIA R CP



144/509



II

E4 024107

200x432 mm



IV

E4 024108

184x160 mm



applicabilità:
applicable to:
Verwendbar für

SCANIA SERIE 4 1996→2004
SCANIA SERIE R/P/T 2004→

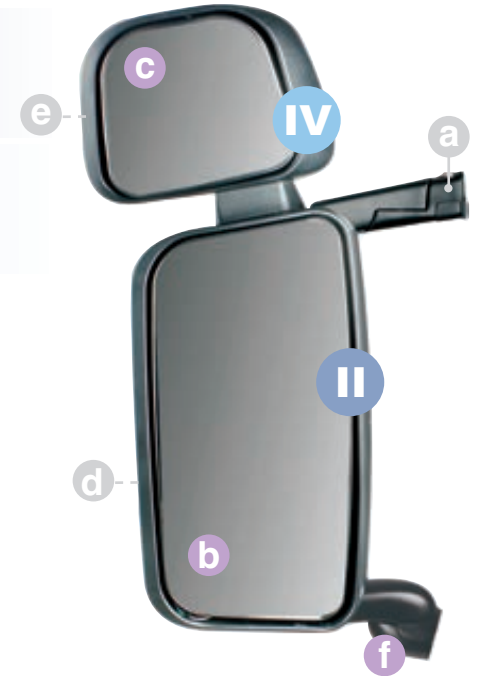
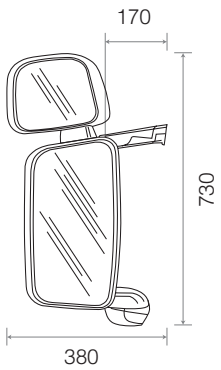

COVIND

144/511







1765809



260x348 mm

IV

150

a	-	-			E4 024107	
b	144/501	1765985	II		200x432 mm	
c	144/502	1767265	IV			E4 024108
d	-	-				
e	-	-				
f	144/512	1346380				

applicabile a | suitable to | verwendbar für:

SCANIA R CP

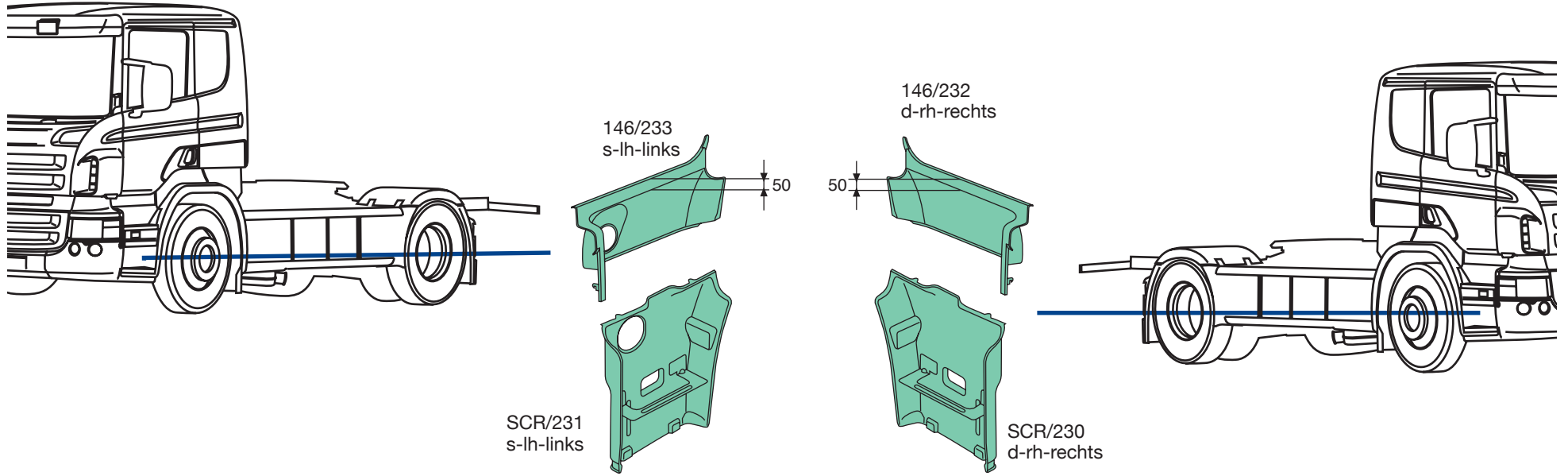

146/232
O.E.M. 1805342



146/233
O.E.M. 1805341



SCR/230
O.E.M. 1854228



SCR/231
O.E.M. 1854227

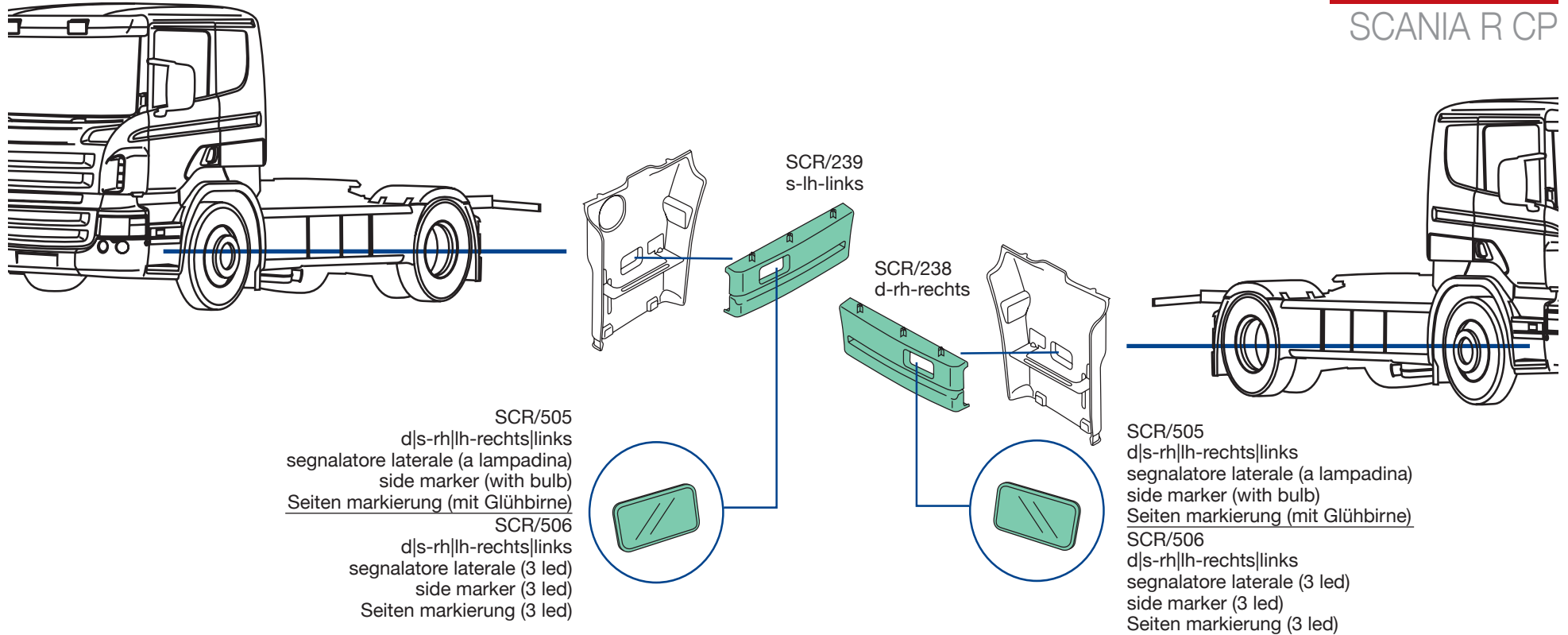

SCR/238
O.E.M. 1779119



SCR/239
O.E.M. 1779118

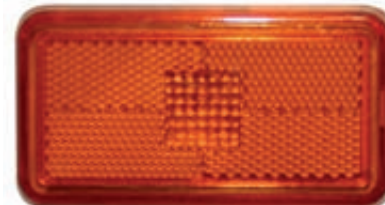

SCR/505
O.E.M. 2052117

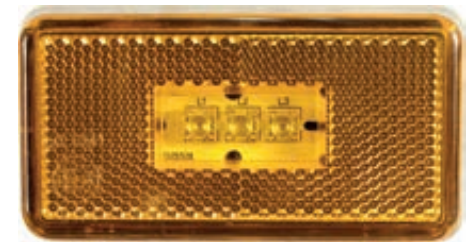

SCR/506
O.E.M. 2080828

applicabile a | suitable to | verwendbar für:

SCANIA R CP

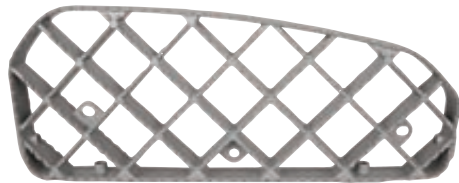
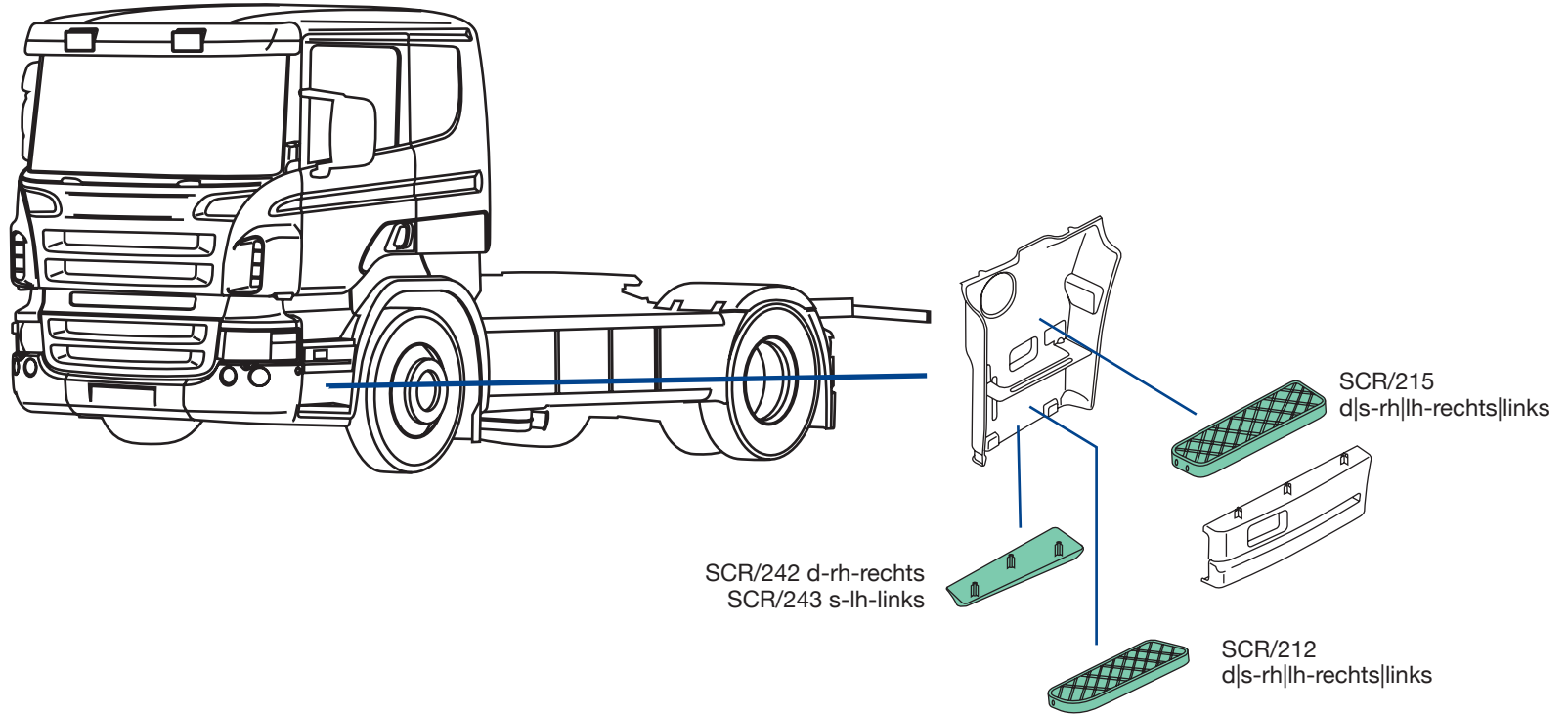

SCR/212
O.E.M. 1535052



SCR/215
O.E.M. 1805447



SCR/242
O.E.M. 1512424
SCR/243
O.E.M. 1512423

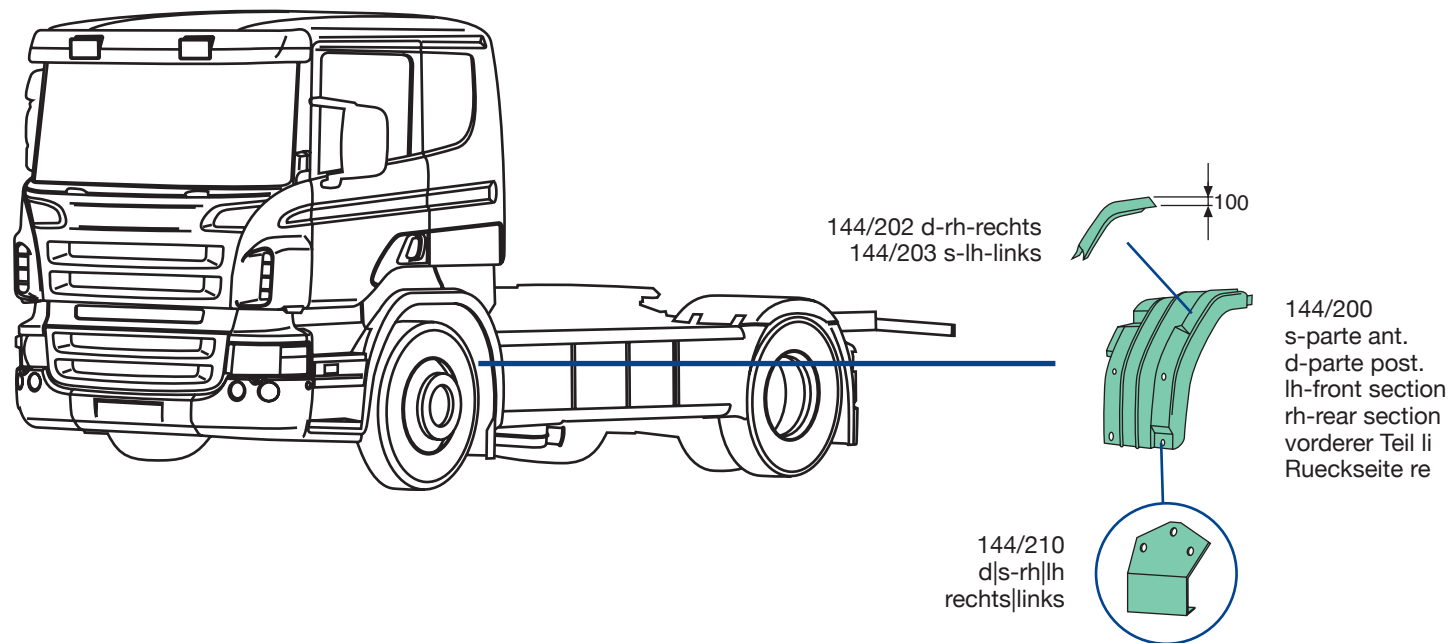

144/200
O.E.M. 1485485



144/210
O.E.M. 1398873



144/202
O.E.M. 1517650
144/203
O.E.M. 1517649

applicabile a | suitable to | verwendbar für:

SCANIA R CP

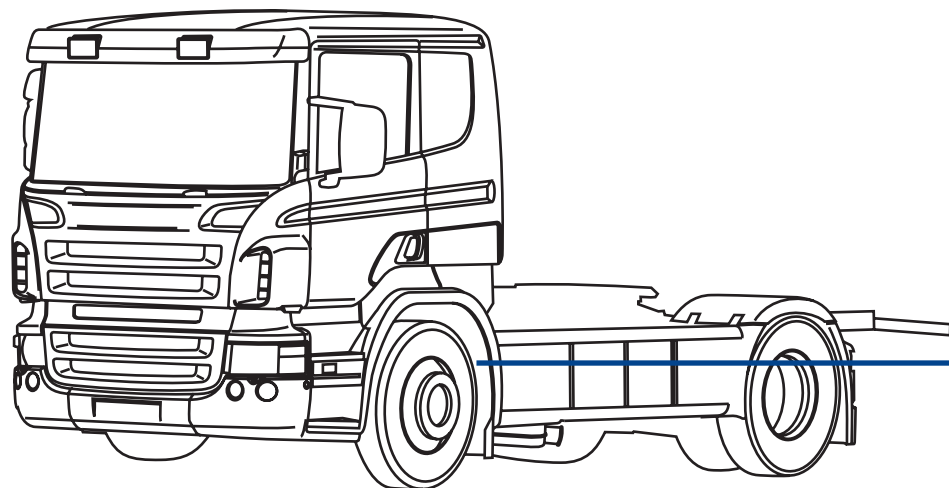

144/220
d|s-rh|lh
rechts|links

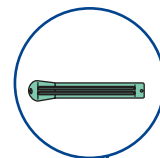

144/206 d-rh-rechts
144/207 s-lh-links

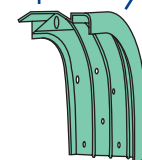

144/204
d-parte ant.
s-parte post.
rh-front section
lh-rear section
vorderer Teil re
Rueckseite li



144/204
O.E.M. 1485486



144/206
O.E.M. 1364666
144/207
O.E.M. 1364665



144/220
O.E.M. 1479924



IT Stampo in acciaio temprato per la produzione della porta anteriore cabina

EN Hardened steel mould for door cab production

DE Gehärtete Stahlform für die Produktion einer Fahrerhausstür

applicabile a | suitable to | verwendbar für:

SCANIA R CP

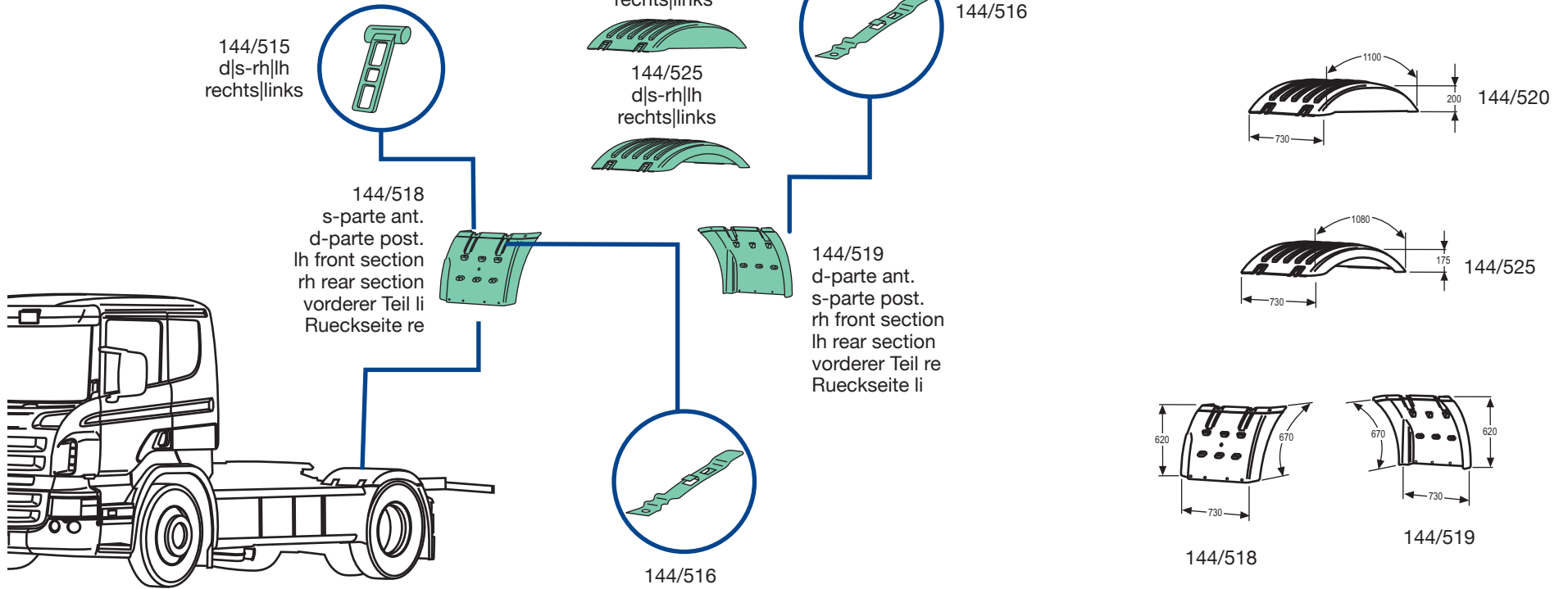

144/515
O.E.M. 1383858



144/516
O.E.M. 2056867

144/520
 O.E.M. 1357601
 d|s-rh|lh-rechts|links
 grigio, circolare, senza cinghietti
 grey, circular, without stretchers
 grau, halbrund, ohne Spanngummi



144/519
 O.E.M. 1357599
 d|s-rh|lh-rechts|links
 grigio, senza anti-spray
 grey, without anti-spray
 grau, ohne Spritzschutz



144/518
 O.E.M. 1357600
 d|s-rh|lh-rechts|links
 grigio
 grey
 grau

144/525
 O.E.M. 1395276
 d|s-rh|lh-rechts|links
 grigio, semipiatta, senza cinghietti
 grey, semi-flat, without stretchers
 grau, halbflach, ohne Spanngummi



144/519

144/518

applicabile a | suitable to | verwendbar für:

SCANIA R CP

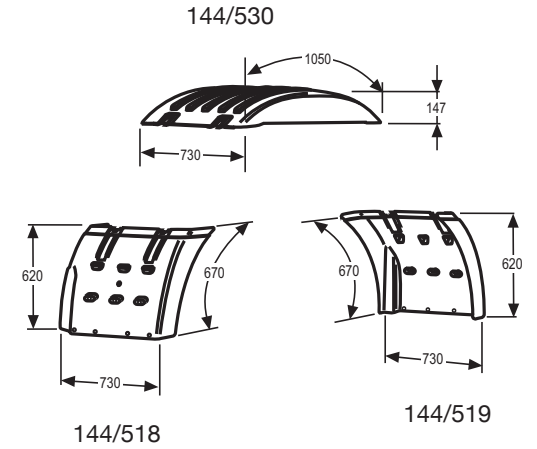
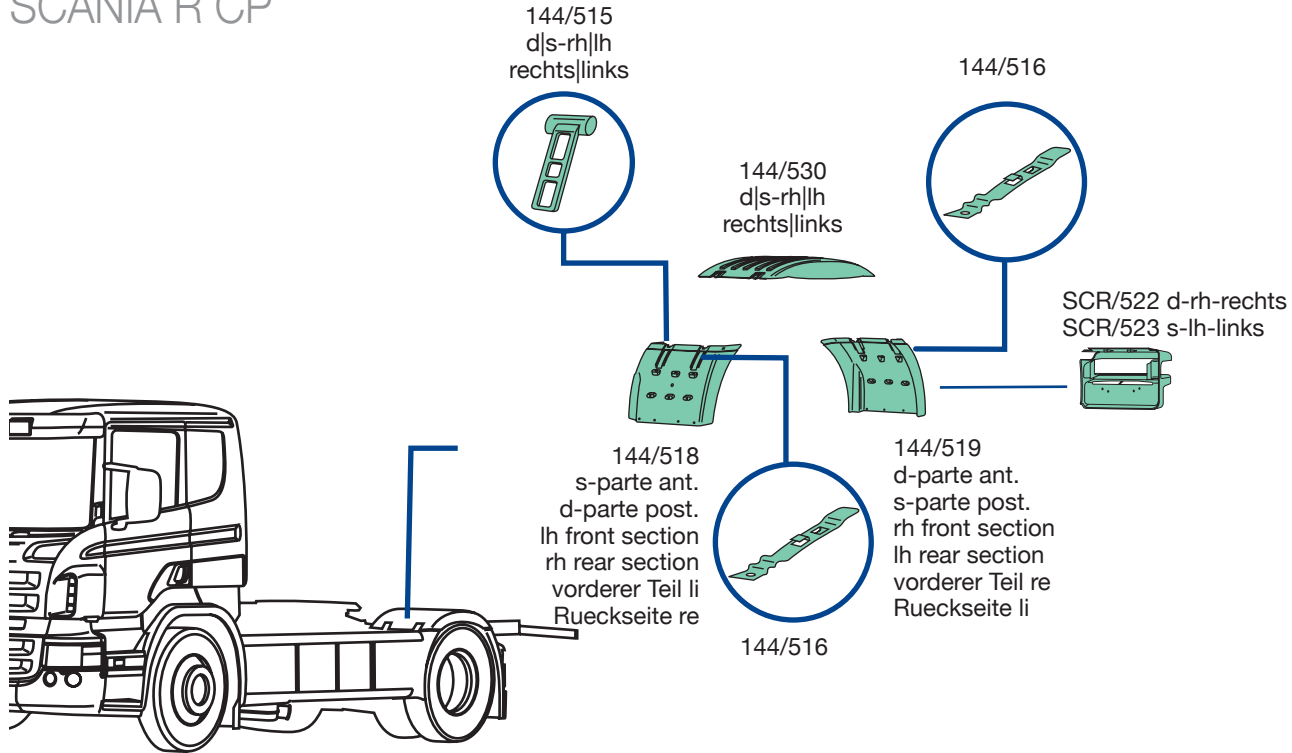

144/515
O.E.M. 1383858



144/516
O.E.M. 2056867



SCR/522
O.E.M. 2026621
SCR/523
O.E.M. 1362708

144/530
 O.E.M. 1357602
 d|s-rh|lh-rechts|links
 grigio, piatta, senza cinghietti
 grey, flat, without stretchers
 grau, flach, ohne Spanngummi

144/519
 O.E.M. 1357599
 d|s-rh|lh-rechts|links
 grigio, senza anti-spray
 grey, without anti-spray
 grau, ohne Spritzschutz

144/518
 O.E.M. 1357600
 d|s-rh|lh-rechts|links
 grigio
 grey
 grau



applicabile a | suitable to | verwendbar für:

SCANIA R CP

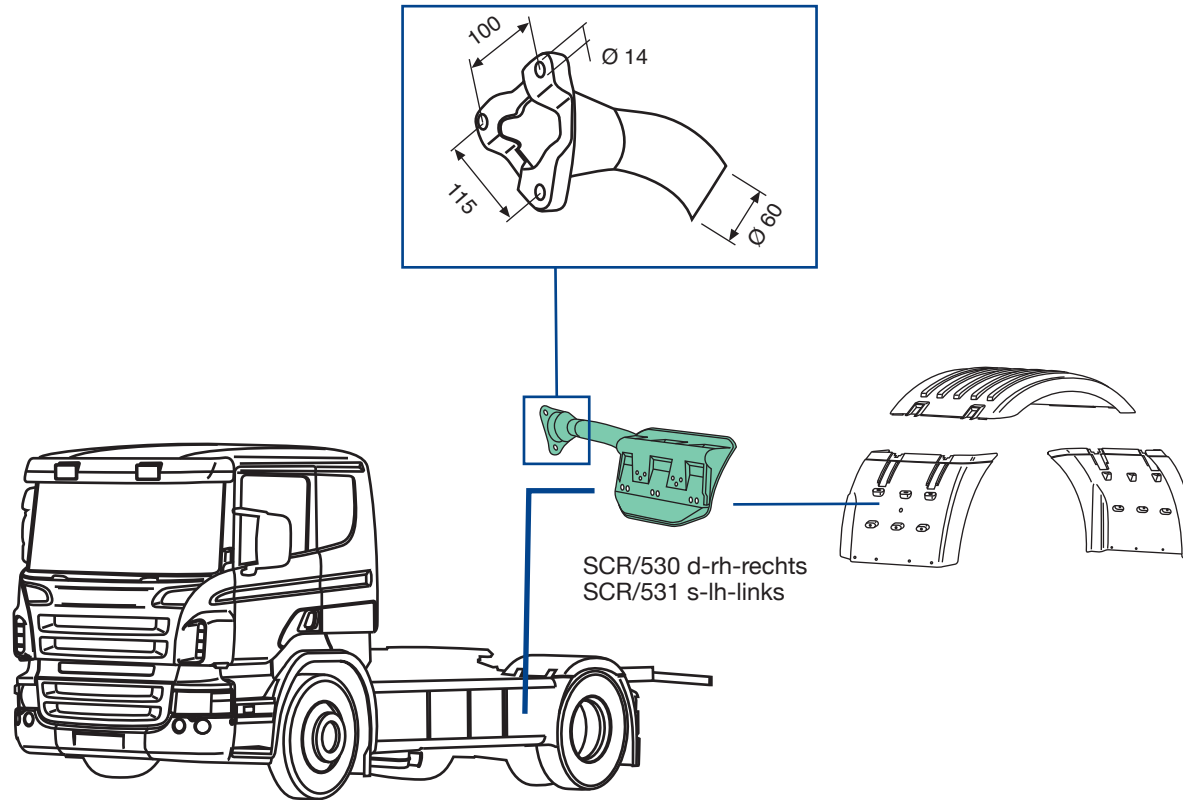



SCR/530
O.E.M. 2054582
anteriore destro
front right
vorne rechts

SCR/531
O.E.M. 2054581
anteriore sinistro
front left
vorne links

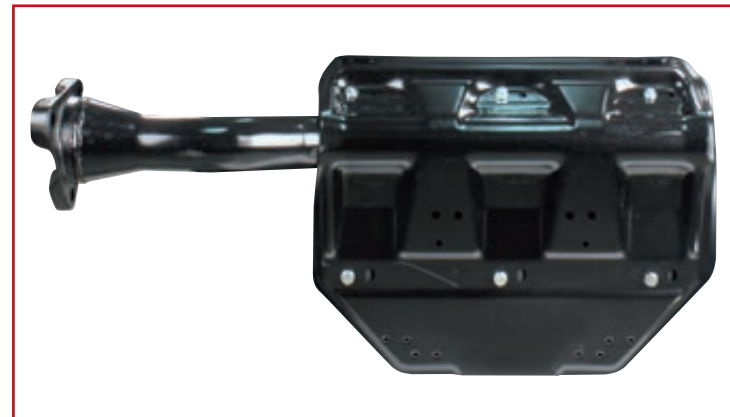

applicabile a | suitable to | verwendbar für:

SCANIA R CP

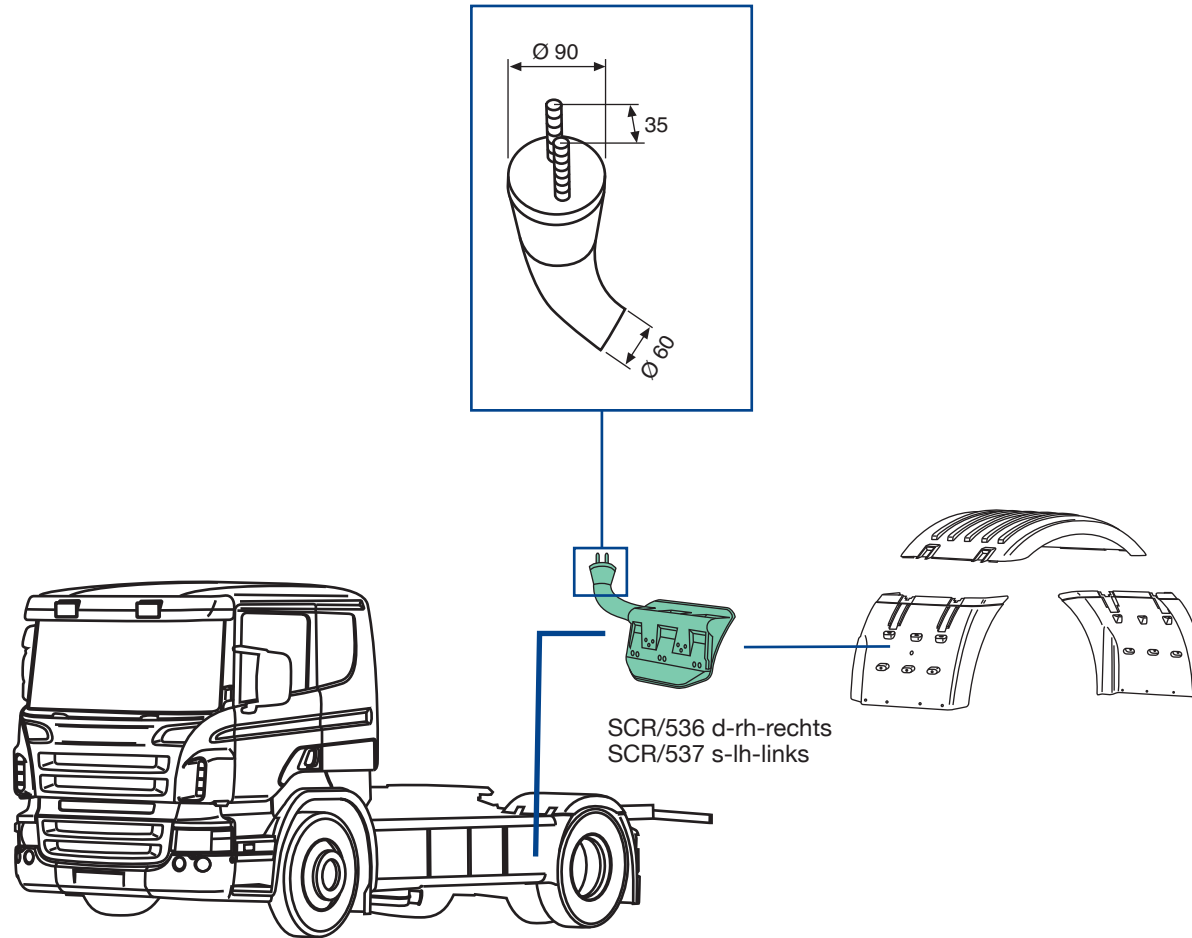



SCR/536
O.E.M. 1457920
anteriore destro
front right
vorne rechts

SCR/537
O.E.M. 1457919
anteriore sinistro
front left
vorne links

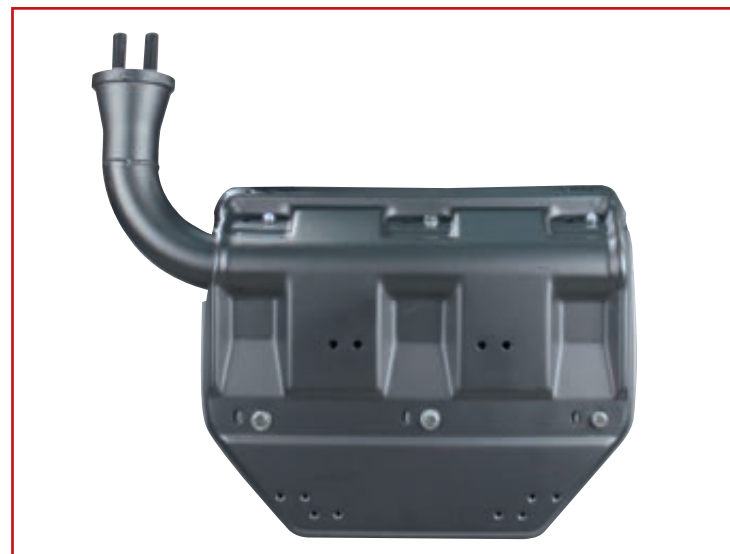

applicabile a | suitable to | verwendbar für:

SCANIA R CP

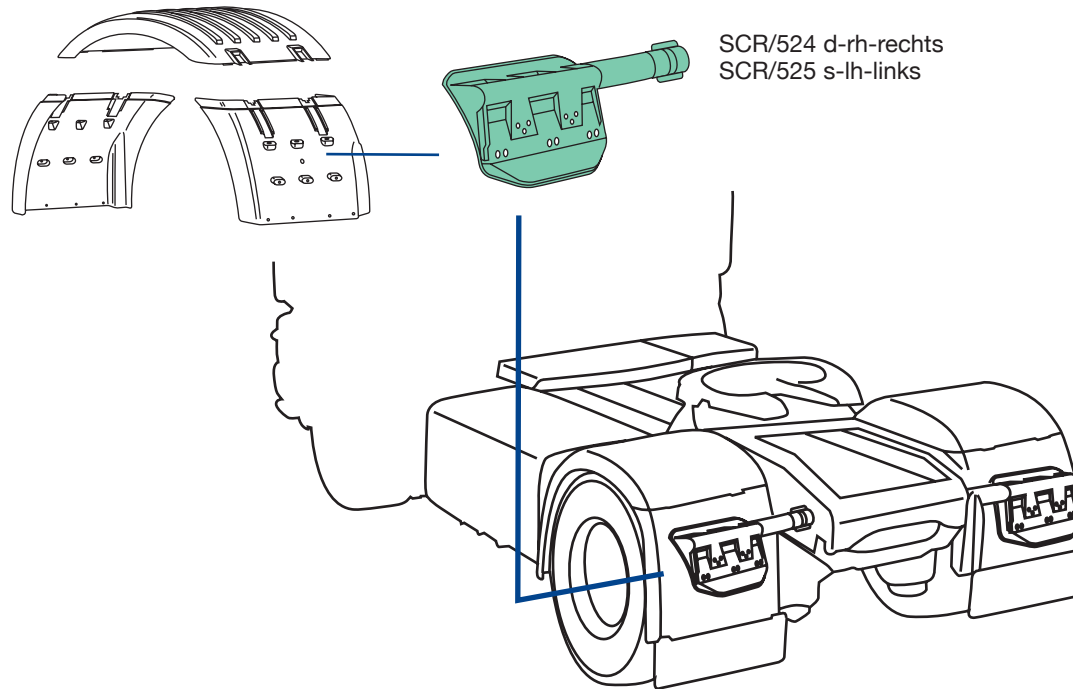



SCR/525
O.E.M. 2054589
posteriore sinistro
rear left
hinten links

SCR/524
O.E.M. 2054590
posteriore destro
rear right
hinten rechts



applicabile a | suitable to | verwendbar für:

SCANIA R CP

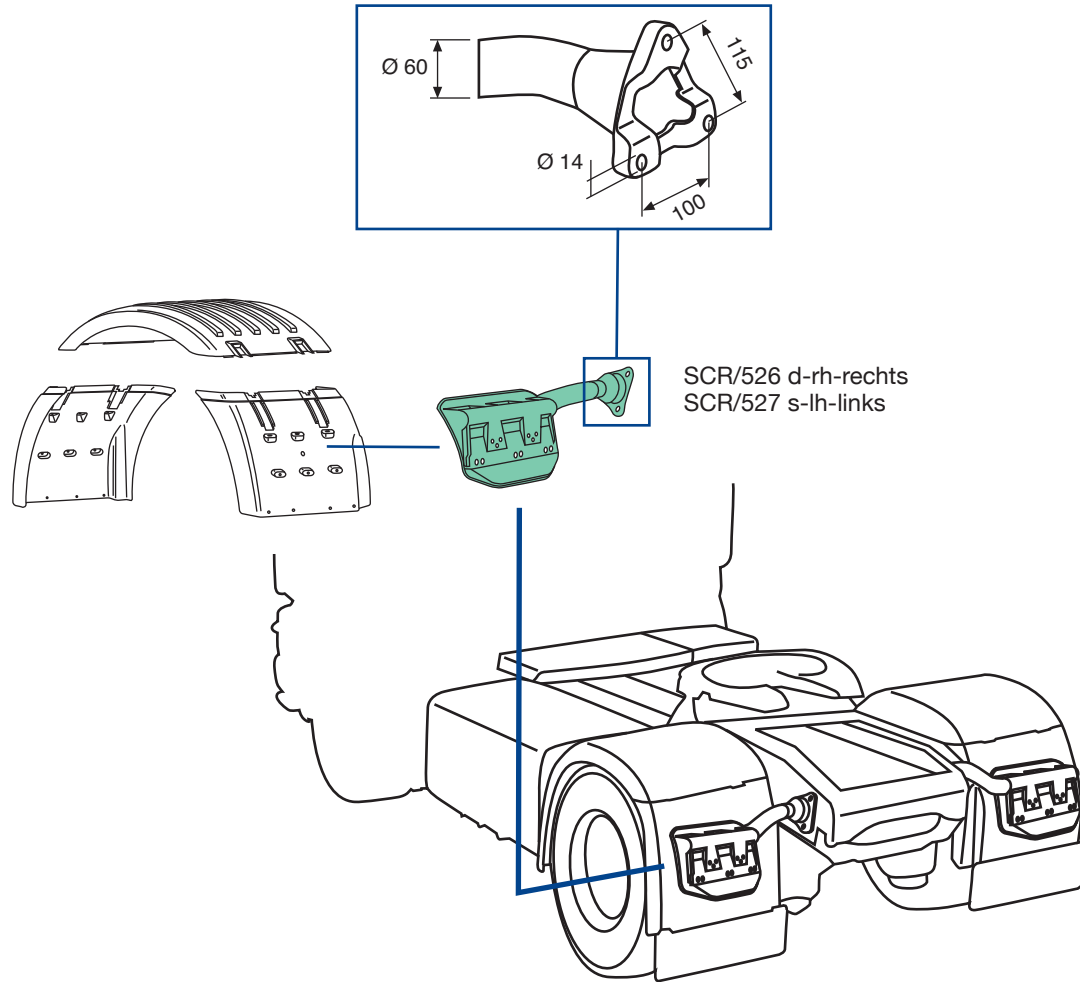



SCR/527
O.E.M. 2054579
posteriore sinistro
rear left
hinten links

SCR/526
O.E.M. 2054580
posteriore destro
rear right
hinten rechts



applicabile a | suitable to | verwendbar für:

SCANIA R CP

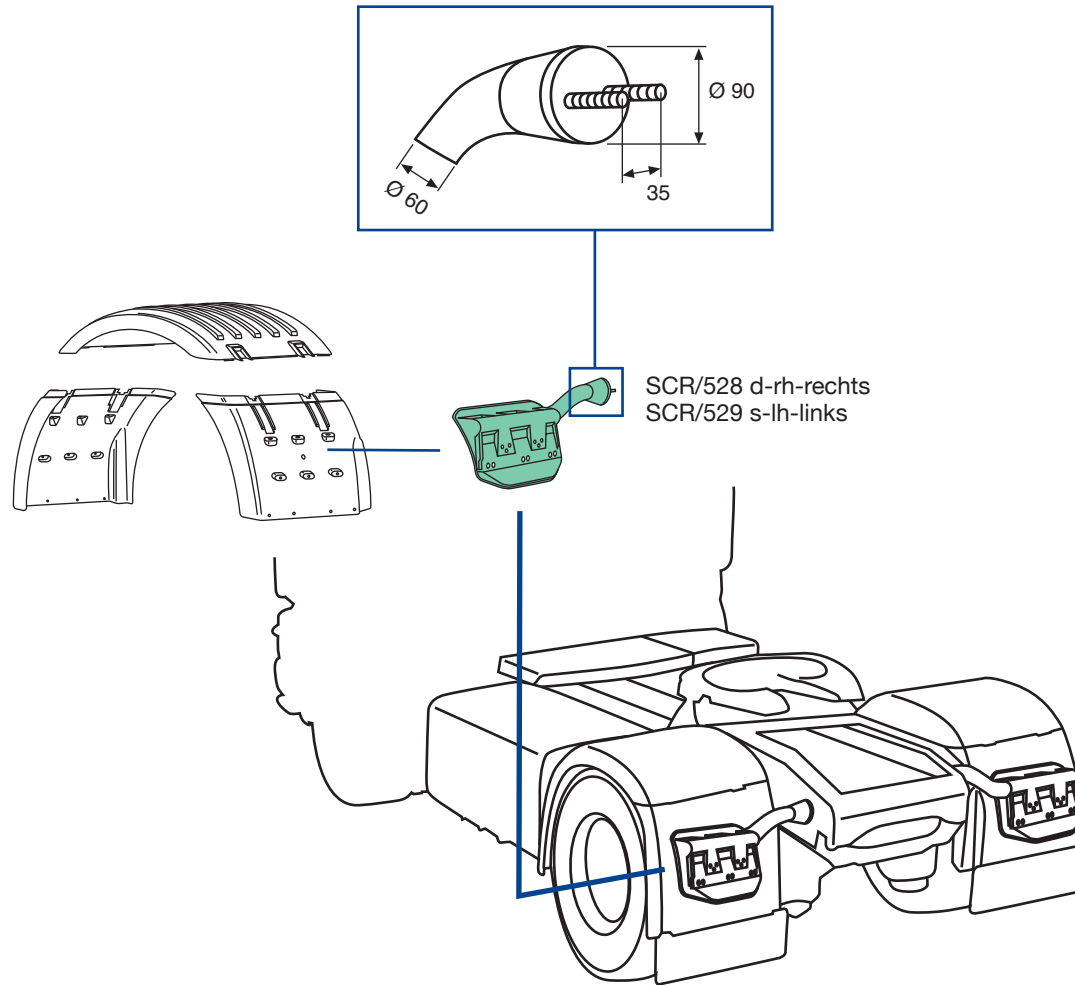



SCR/529
O.E.M. 2054603
posteriore sinistro
rear left
hinten links

SCR/528
O.E.M. 2054604
posteriore destro
rear right
hinten rechts



applicabile a | suitable to | verwendbar für:

SCANIA R CP

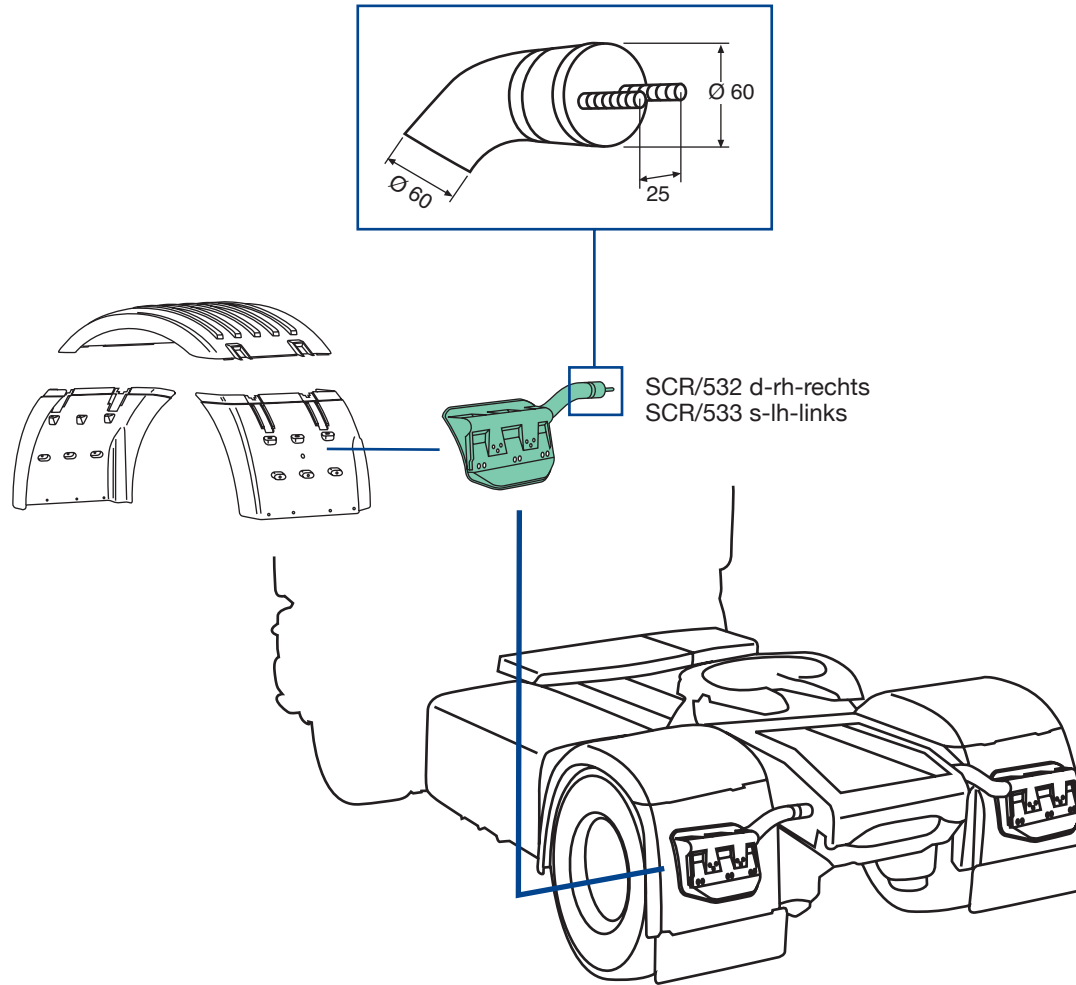



SCR/533
O.E.M. 1457929
posteriore sinistro
rear left
hinten links

SCR/532
O.E.M. 1457930
posteriore destro
rear right
hinten rechts



applicabile a | suitable to | verwendbar für:

SCANIA R CP

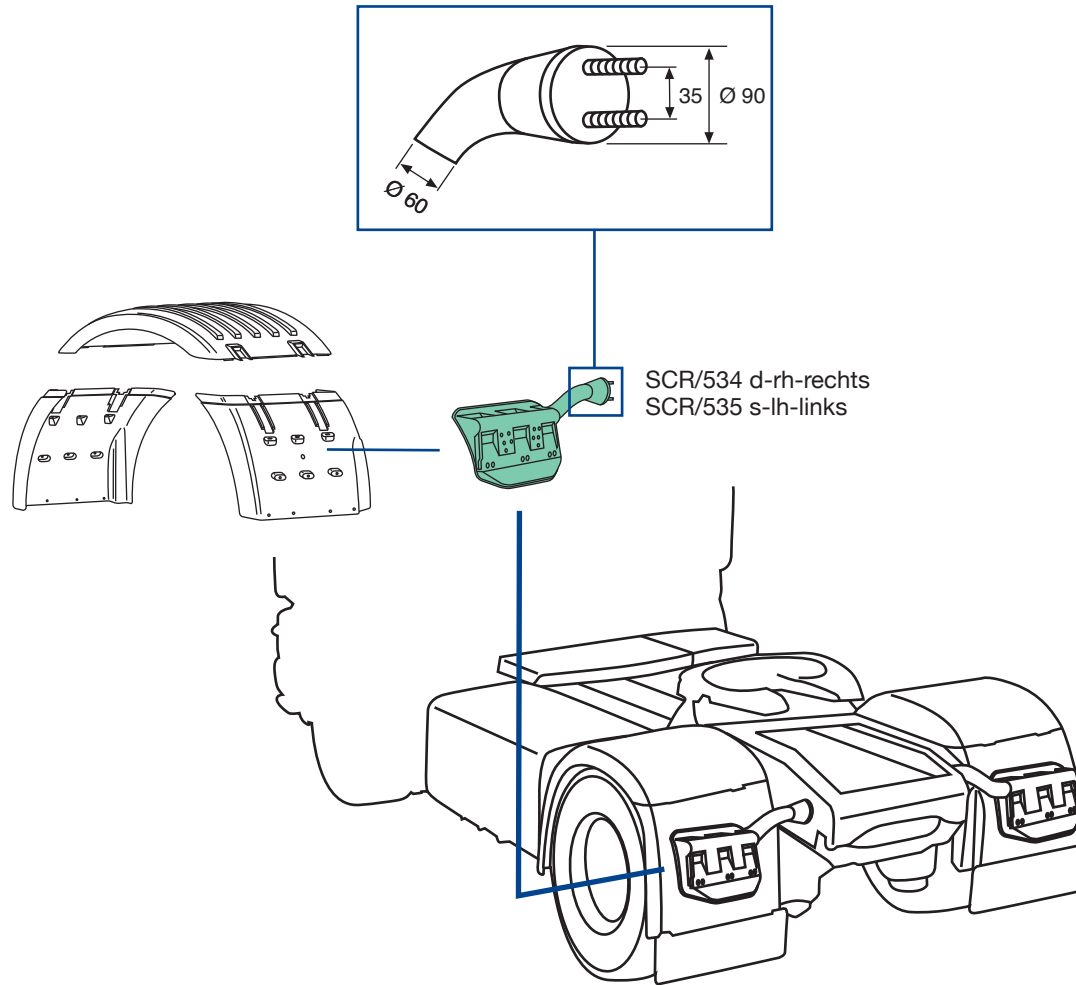



SCR/535
O.E.M. 2054601
posteriore sinistro
rear left
hinten links

SCR/534
O.E.M. 2054602
posteriore destro
rear right
hinten rechts



applicabile a | suitable to | verwendbar für:

SCANIA R CP

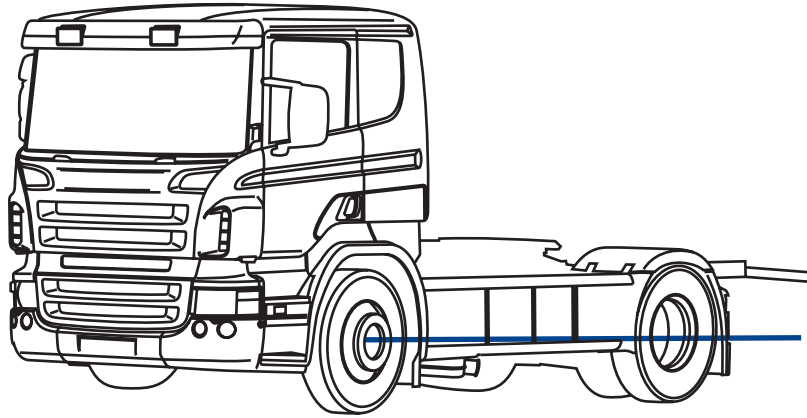

930/033

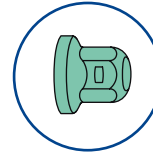

930/100
d-rh-rechts
930/101
s-lh-links



930/001
d-rh-rechts
930/002
s-lh-links

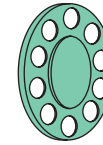

930/200
d|s-rh|lh
rechts|links

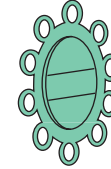

930/033
O.E.M. -



930/001
O.E.M. -
930/002
O.E.M. -



930/100
O.E.M. -
930/101
O.E.M. -



930/200
O.E.M. -

930/033 - Tappo copri Bullone - Bolt cover - Radmutterkappen

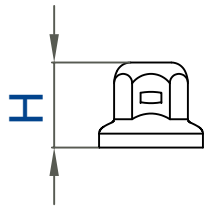

H	45 mm
Per bulloni \varnothing - bolt \varnothing	33 mm
Schlüsselweite \varnothing	
Colore	cromato-chrome-verchromt
Colours-Farbe	
Materiale-Material	acciaio inox-stainless steel Edelstahl
Kg	0,025

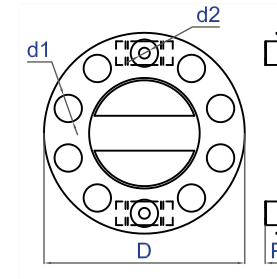

930/001 d-rh-rechts - 930/002 s-lh-links

D \varnothing 425 mm	P 50 mm
d1 nr. 10	d1 \varnothing 58 mm
d2 nr. 2	d2 \varnothing 23 mm
Ventilata	si-yes-Ja
Ventilated-Belüftet	
Colore	cromato e nero-chrome and black
Colours-Farbe	verchromt und schwarz
Materiale-Material	acciaio inox e plastica stainless steel and plastic Edelstahl und Kunststoff
Kg	1,230

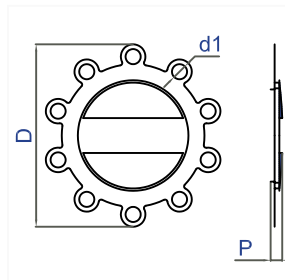

930/100 d-rh-rechts - 930/101 s-lh-links

D \varnothing 387 mm	P 30 mm
d1 nr. 10	d1 \varnothing 32 mm
Ventilata	si-yes-Ja
Ventilated-Belüftet	
Colore	cromato e nero-chrome and black
Colours-Farbe	verchromt und schwarz
Materiale-Material	acciaio inox e plastica stainless steel and plastic Edelstahl und Kunststoff
Kg	0,655

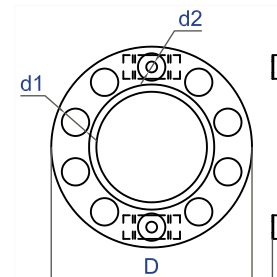

930/200 d|s-rh|lh-rechts|links

D \varnothing 425 mm	P 40 mm
d1 nr. 10	d1 \varnothing 58 mm
d2 nr. 2	d2 \varnothing 23 mm
Ventilata	no-nein
Ventilated-Belüftet	
Colore	cromato-chrome-verchromt
Colours-Farbe	
Materiale-Material	acciaio inox-stainless steel Edelstahl
Kg	1,155



IT Officina di riparazione
EN Workshop
DE Werkstatt



applicabile a | suitable to | verwendbar für

179

SCR
SCANIA R CG-CR

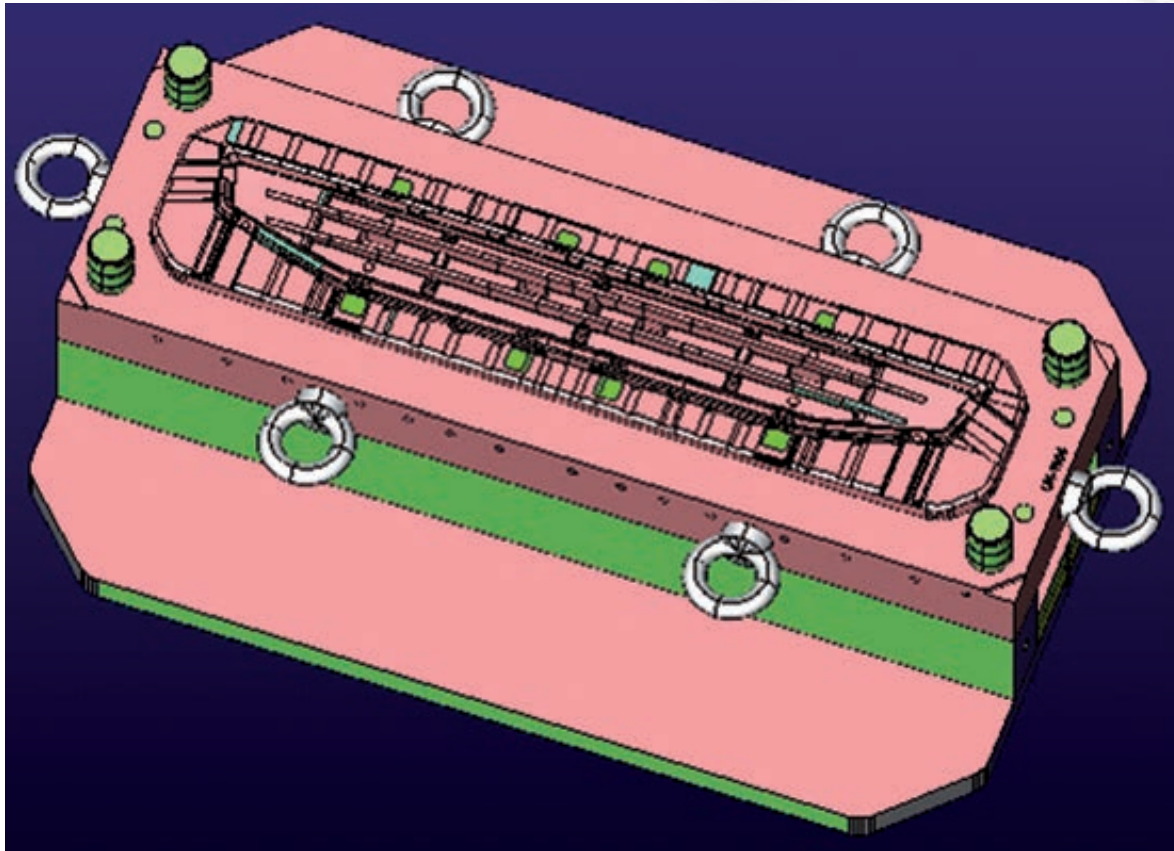

IT Progetto in 3D dello stampo ad iniezione per la produzione di griglie

EN 3D project of injection mould for grill production

DE 3D Projekt, einer Spritzgußform für die Grill Produktion

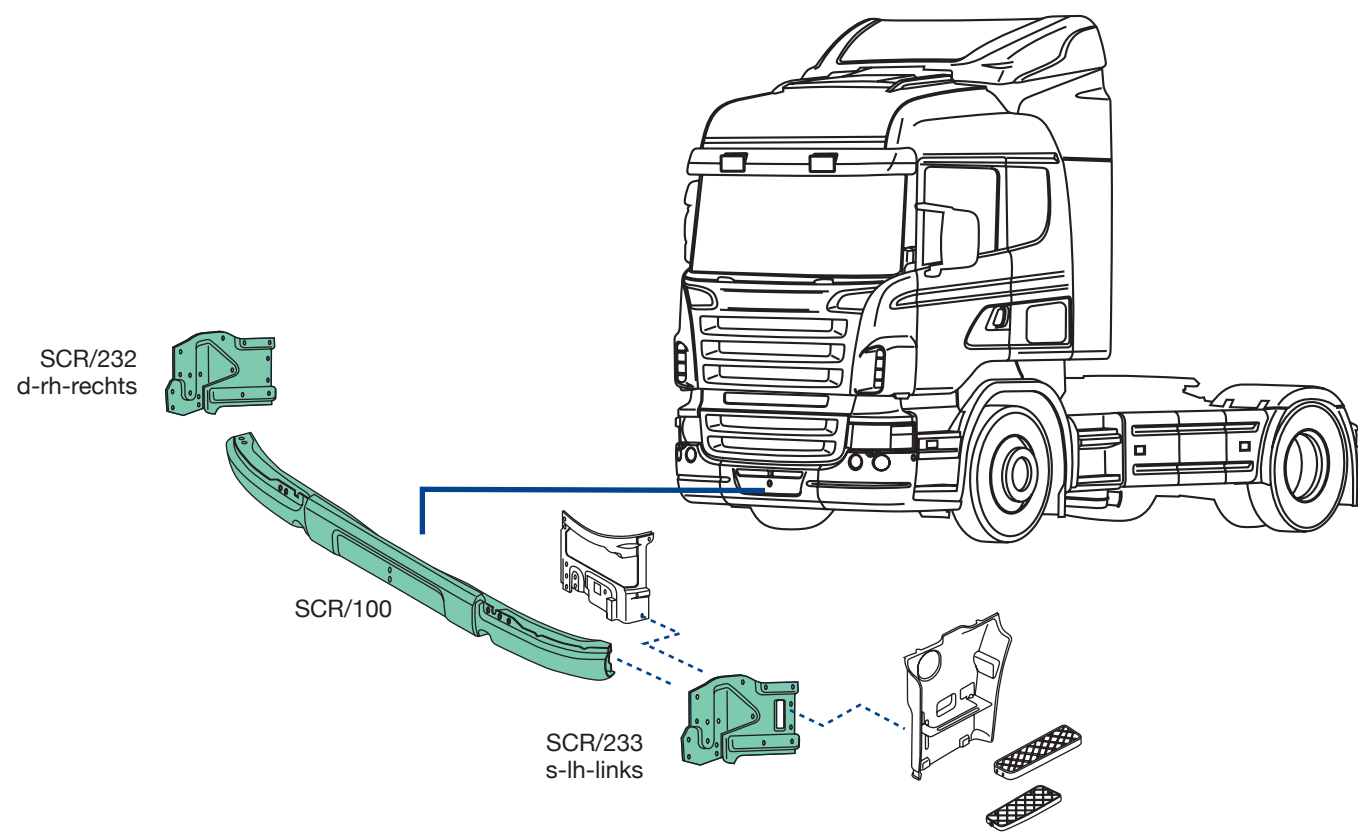

SCR/100
O.E.M. 1763296



SCR/232
O.E.M. 1431585

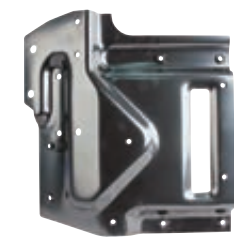

SCR/233
O.E.M. 1431584

applicabile a | suitable to | verwendbar für:

SCANIA R CG-CR

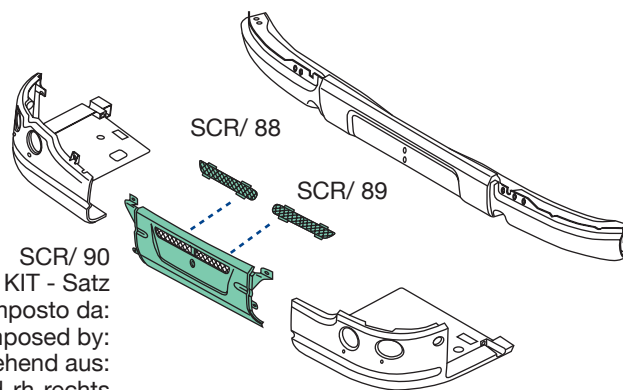

SCR/ 90
KIT - Satz
composto da:
composed by:
bestehend aus:
SCR/ 88 d-rh-rechts
SCR/ 89 s-lh-links
1539397 (pz.-pcs-st. 8)
1431924 (pz.-pcs-st. 1)

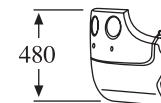
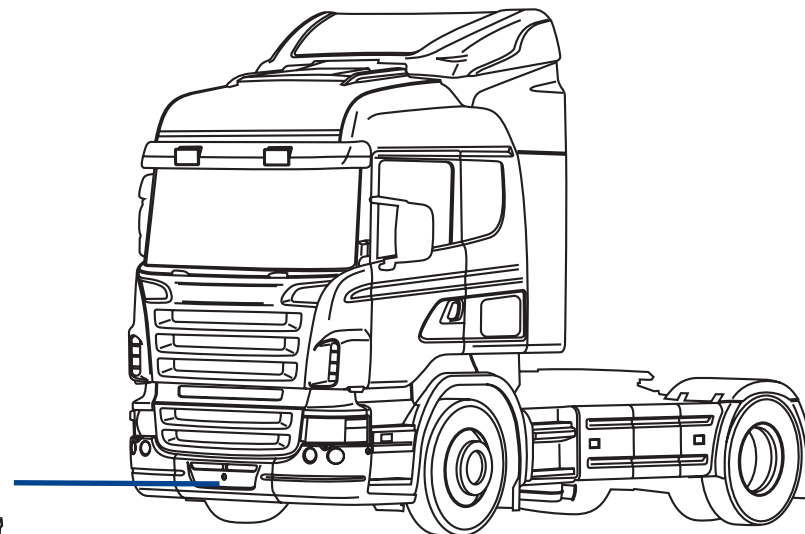

per paraurti basso
for low bumper
für niedrigen Stoßfänger



SCR/ 88
O.E.M. 1495578
SCR/ 89
O.E.M. 1495577



SCR/ 90
O.E.M. 1504131

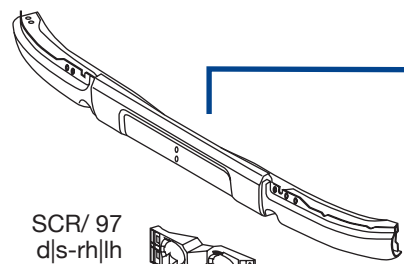
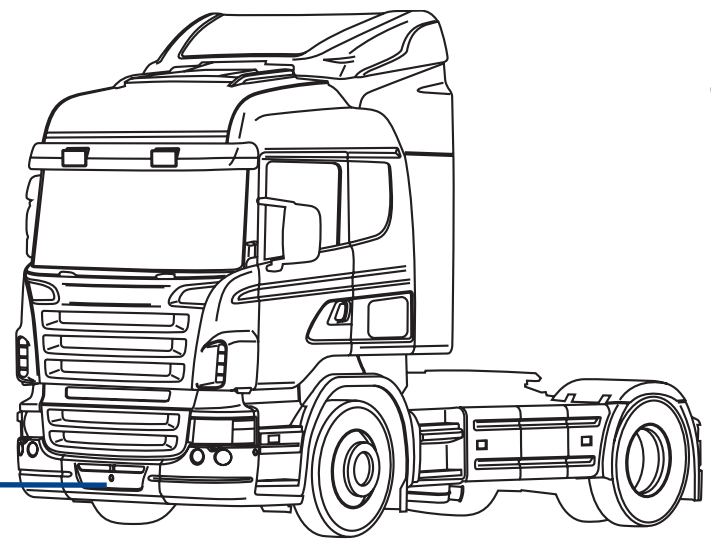

SCR/ 92

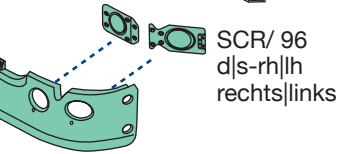

SCR/ 93

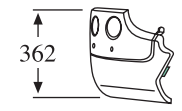

per paraurti alto
for high bumper
für hohe Stoßfänger



SCR/ 92
O.E.M. 1439789
SCR/ 93
O.E.M. 1439788



SCR/ 96
O.E.M. 1523509



SCR/ 97
O.E.M. 1523508

applicabile a | suitable to | verwendbar für:

SCANIA R CG-CR

(*) Larghezza telaio mm 1020 - chassis width 1020 mm - Chassis: Breite 1020 Millimeter (mm)

SCR/192(*)



SCR/ 98
d-rh-rechts
SCR/ 99
s-lh-links
con cerniera
with hinge
mit Scharnier
(1493381+1509091)

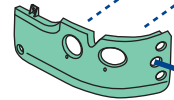
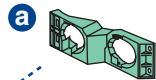

SCR/193(*)

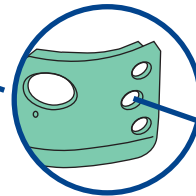

SCR/190
d|s-rh|lh
rechts|links

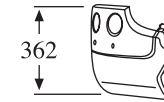
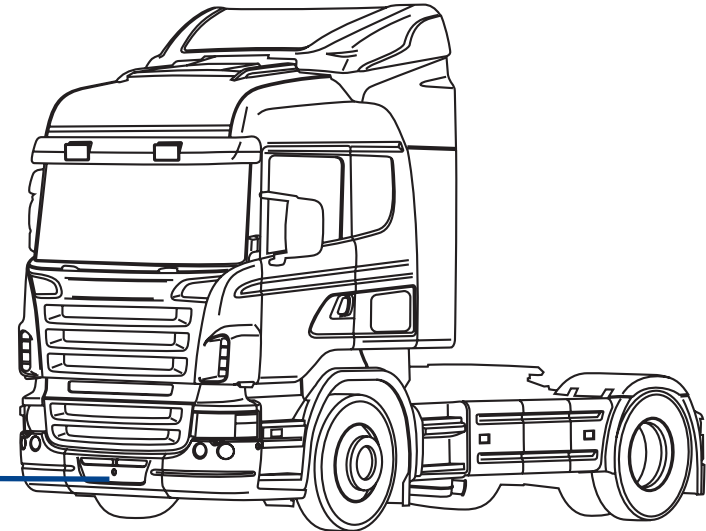
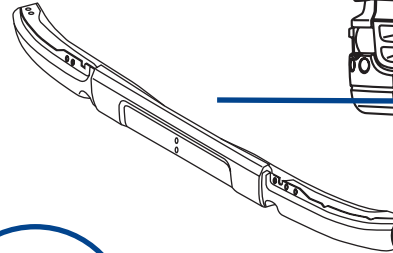

362

per paraurti alto
for high bumper
für hohe Stoßfänger



SCR/ 98
O.E.M. 1786693
SCR/ 99
O.E.M. 1786692

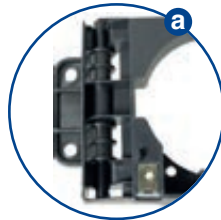

SCR/190
O.E.M. 1923152



SCR/192
O.E.M. 1853194
SCR/193
O.E.M. 1853193

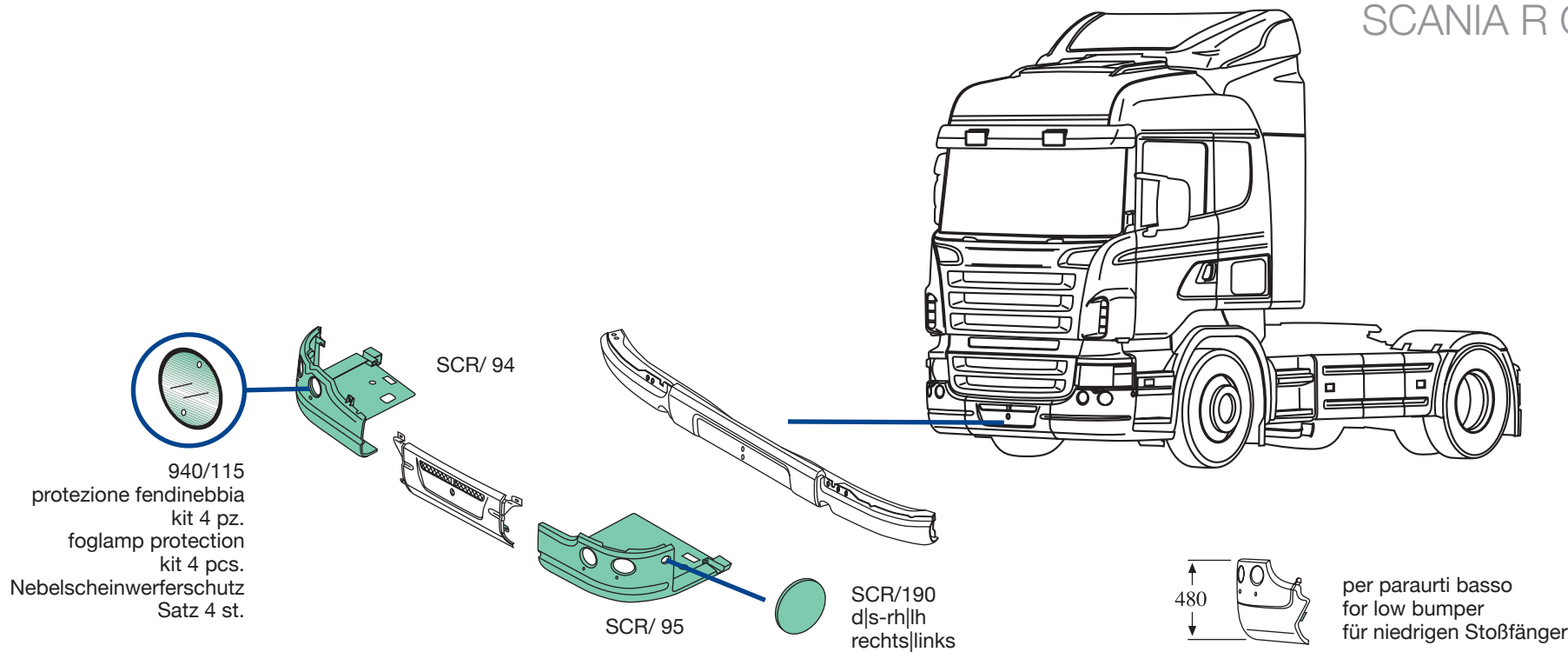

940/115
O.E.M. -



SCR/ 94
O.E.M. 1853347
SCR/ 95
O.E.M. 1853346



SCR/190
O.E.M. 1923152

applicabile a | suitable to | verwendbar für:

SCANIA R CG-CR

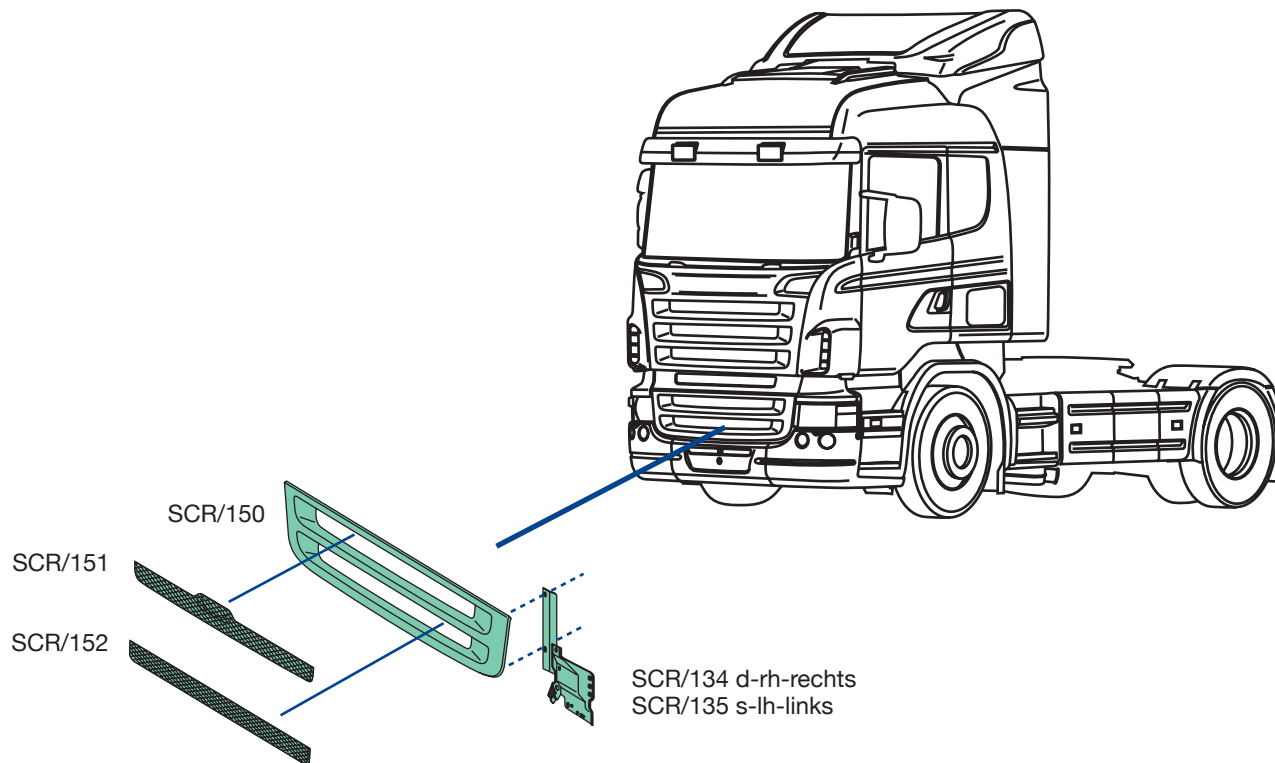

SCR/134
O.E.M. 1742265
SCR/135
O.E.M. 1742264



SCR/150
O.E.M. 1536807



SCR/151
O.E.M. 1459141



SCR/152
O.E.M. 1459142

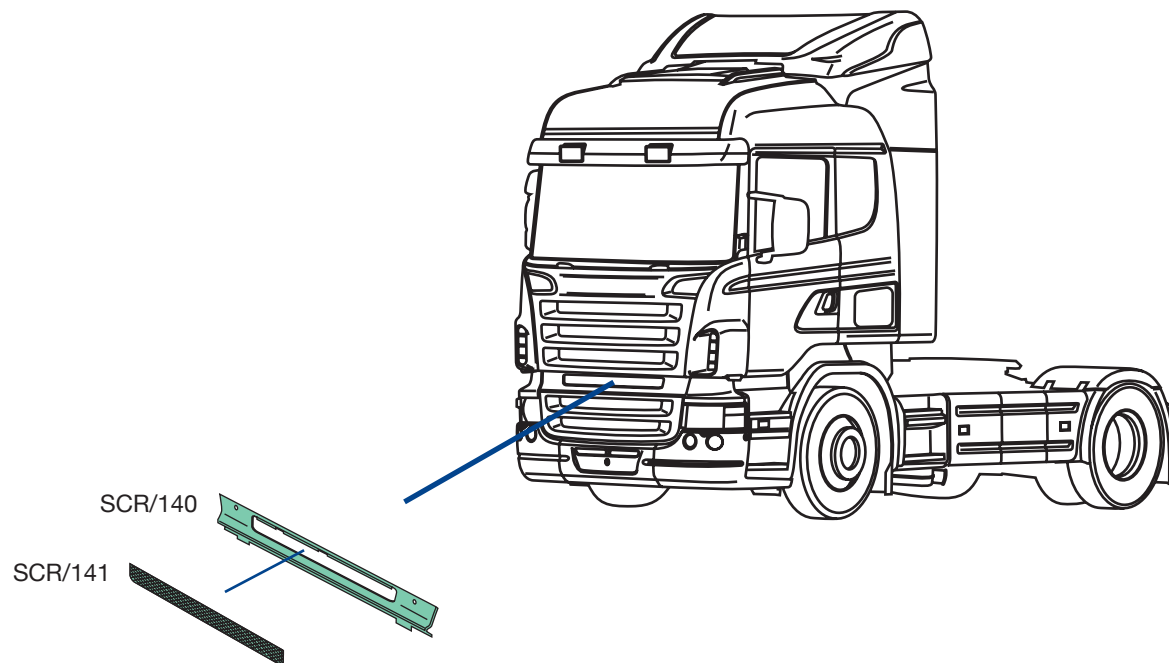

SCR/140
O.E.M. 1748085



SCR/141
O.E.M. 1459145

applicabile a | suitable to | verwendbar für:

SCANIA R CG-CR

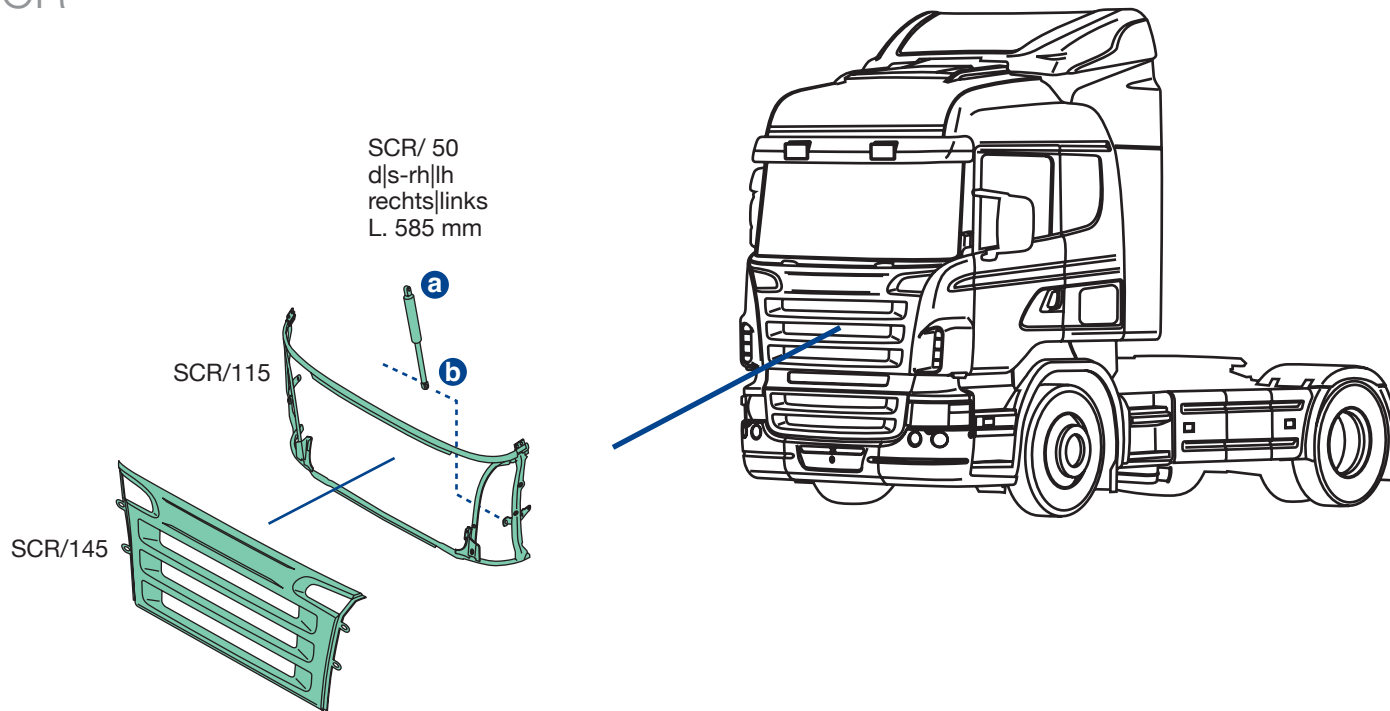

SCR/ 50
O.E.M. 1435542



SCR/115
O.E.M. 1804628



SCR/145
O.E.M. 1880736

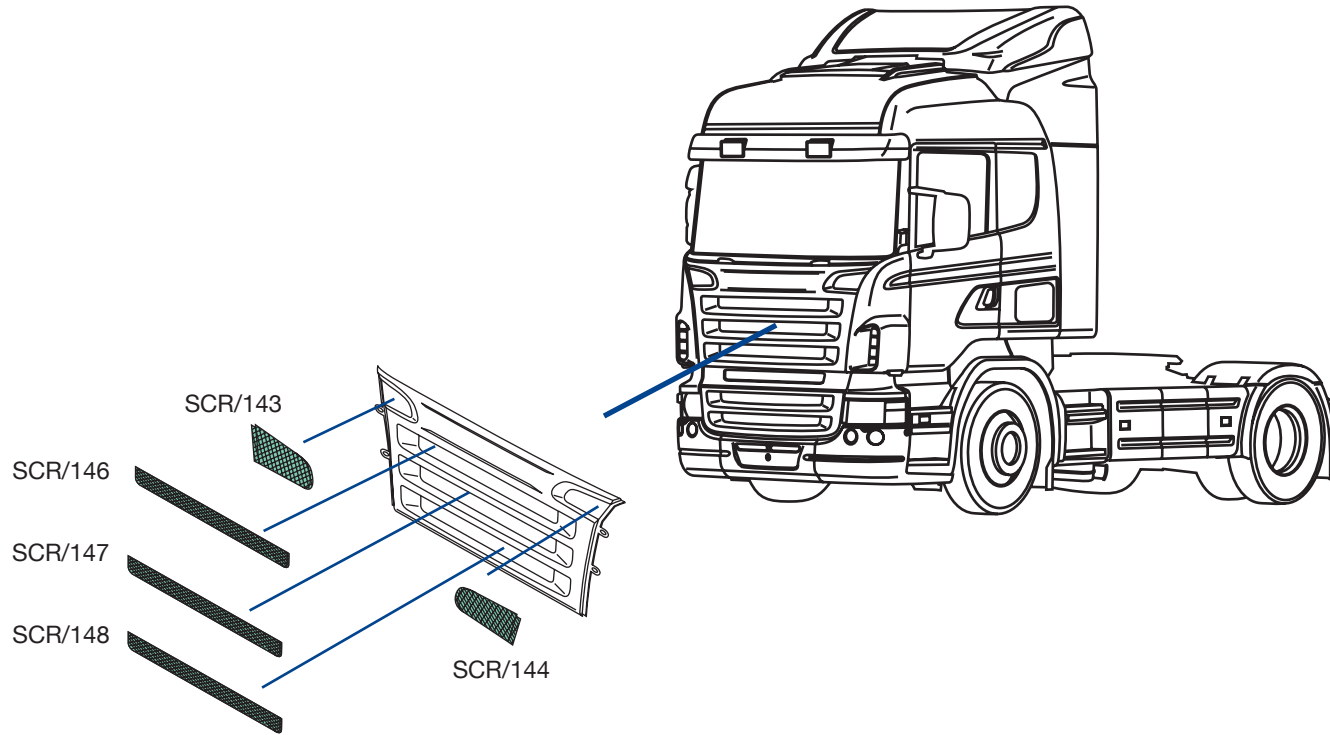

SCR/143
O.E.M. 1466032
SCR/144
O.E.M. 1466031



SCR/146
O.E.M. 1459133



SCR/147
O.E.M. 1880737



SCR/148
O.E.M. 1459135

applicabile a | suitable to | verwendbar für:

SCANIA R CG-CR

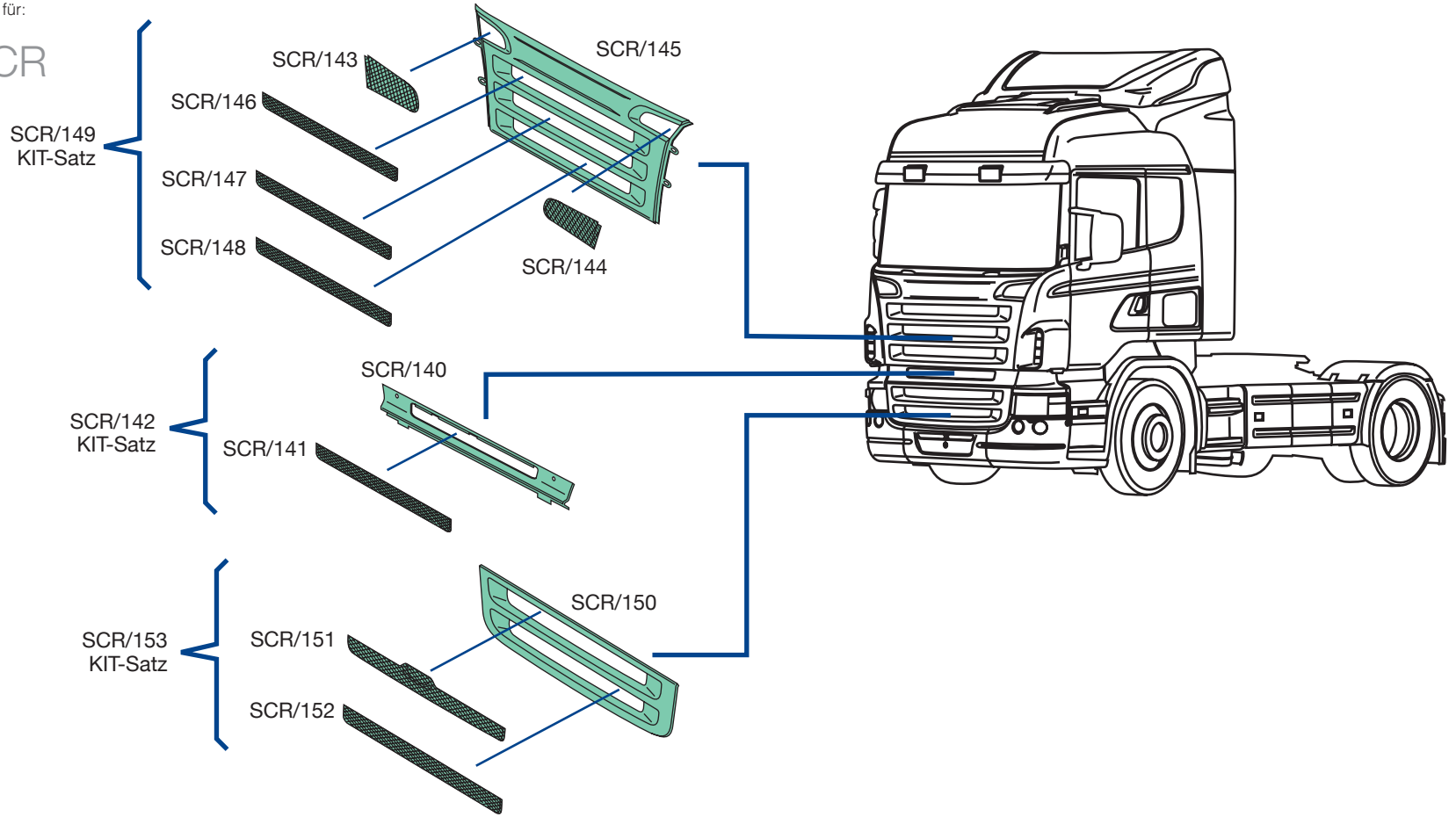

SCR/142
O.E.M. -



SCR/149
O.E.M. -



SCR/153
O.E.M. -

SCANIA R CG-CR

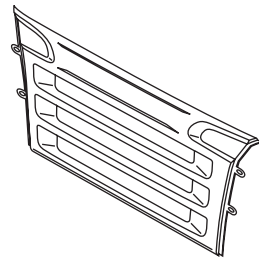
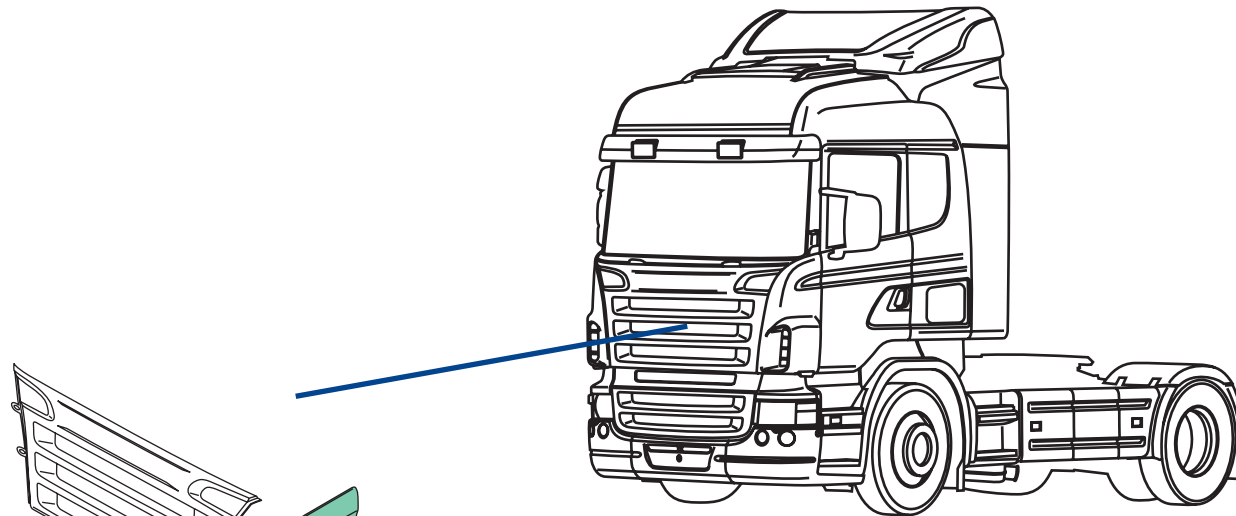

SCR/160 d-rh-rechts
SCR/161 s-lh-links



SCR/164
d-rh-rechts
SCR/165
s-lh-links
cabina
cab
Fhs.
CR



146/162 d-rh-rechts
146/163 s-lh-links
cabina
cab
Fhs.
CG



146/162
O.E.M. 1856476
146/163
O.E.M. 1856477

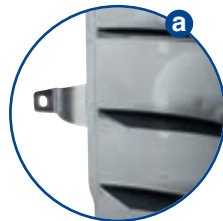

SCR/160
O.E.M. 1751406
SCR/161
O.E.M. 1751405



SCR/164
O.E.M. 1856474
SCR/165
O.E.M. 1856475

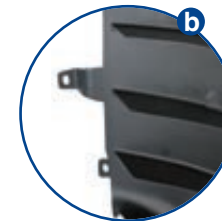

applicabile a | suitable to | verwendbar für:

SCANIA R CG-CR

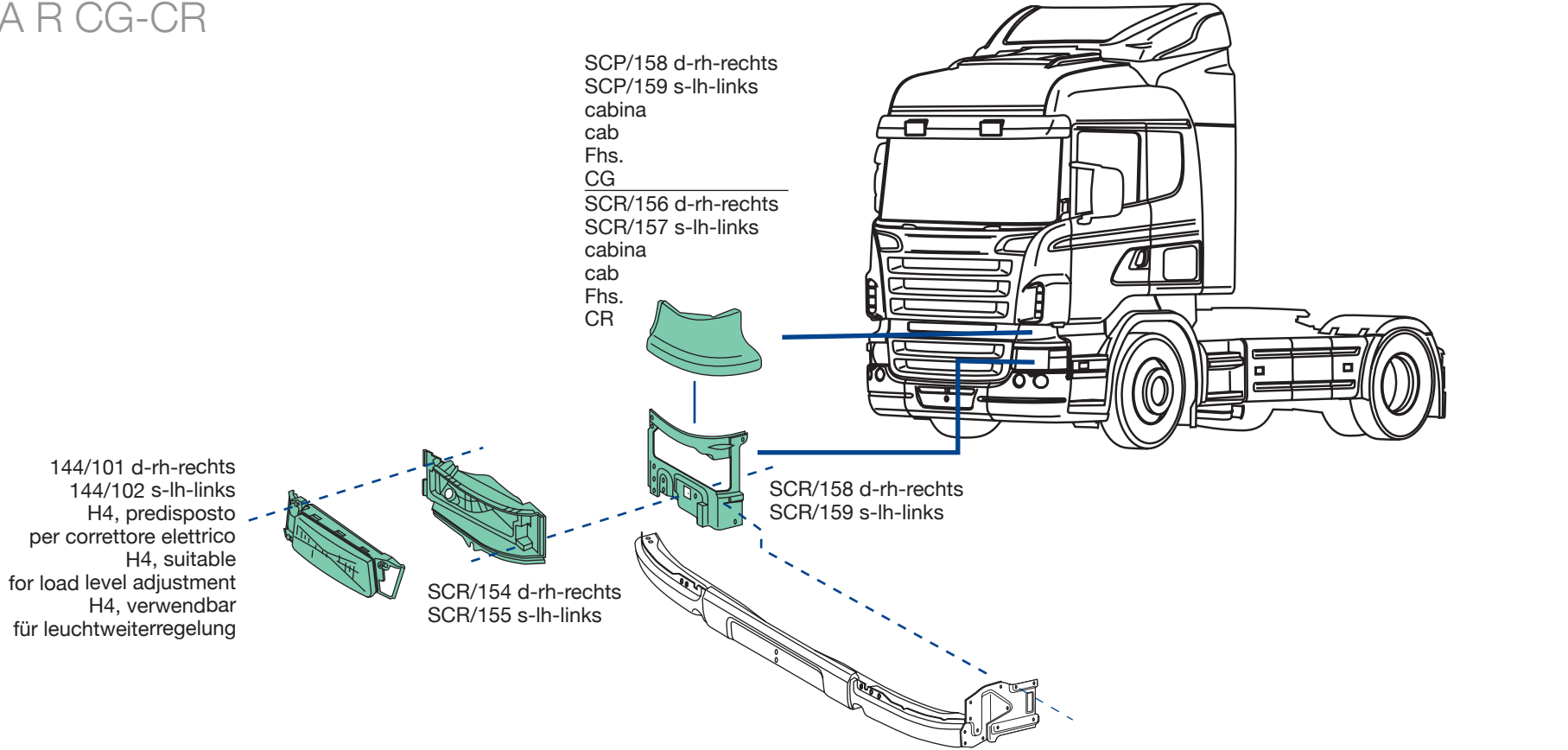

144/101
O.E.M. 1732510
144/102
O.E.M. 1732509



SCR/154
O.E.M. 1936675
SCR/155
O.E.M. 1936674



SCR/158
O.E.M. 1727992
SCR/159
O.E.M. 1727991



SCP/158
O.E.M. 1438564
SCP/159
O.E.M. 2124011

SCR/156
O.E.M. 1431923
SCR/157
O.E.M. 2124015

SCR/ 2 d-rh-rechts
SCR/ 3 s-lh-links
lastrata, con cerniere
paneled with hinges
rohbautür, mit Scharnier

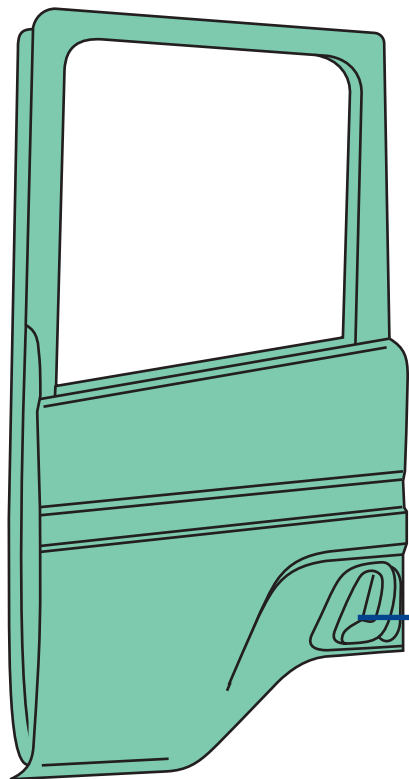

144/194 d-rh-rechts
144/195 s-lh-links



144/196
d|s-rh|lh
rechts|links

SCR/194 d-rh-rechts
SCR/195 s-lh-links



SCR/ 2
O.E.M. 1476535
SCR/ 3
O.E.M. 1476534



144/194
O.E.M. 2145648
144/195
O.E.M. 2145647



144/196
O.E.M. 1485072



SCR/194
O.E.M. -
SCR/195
O.E.M. -

applicabile a | suitable to | verwendbar für:

SCANIA R CG-CR

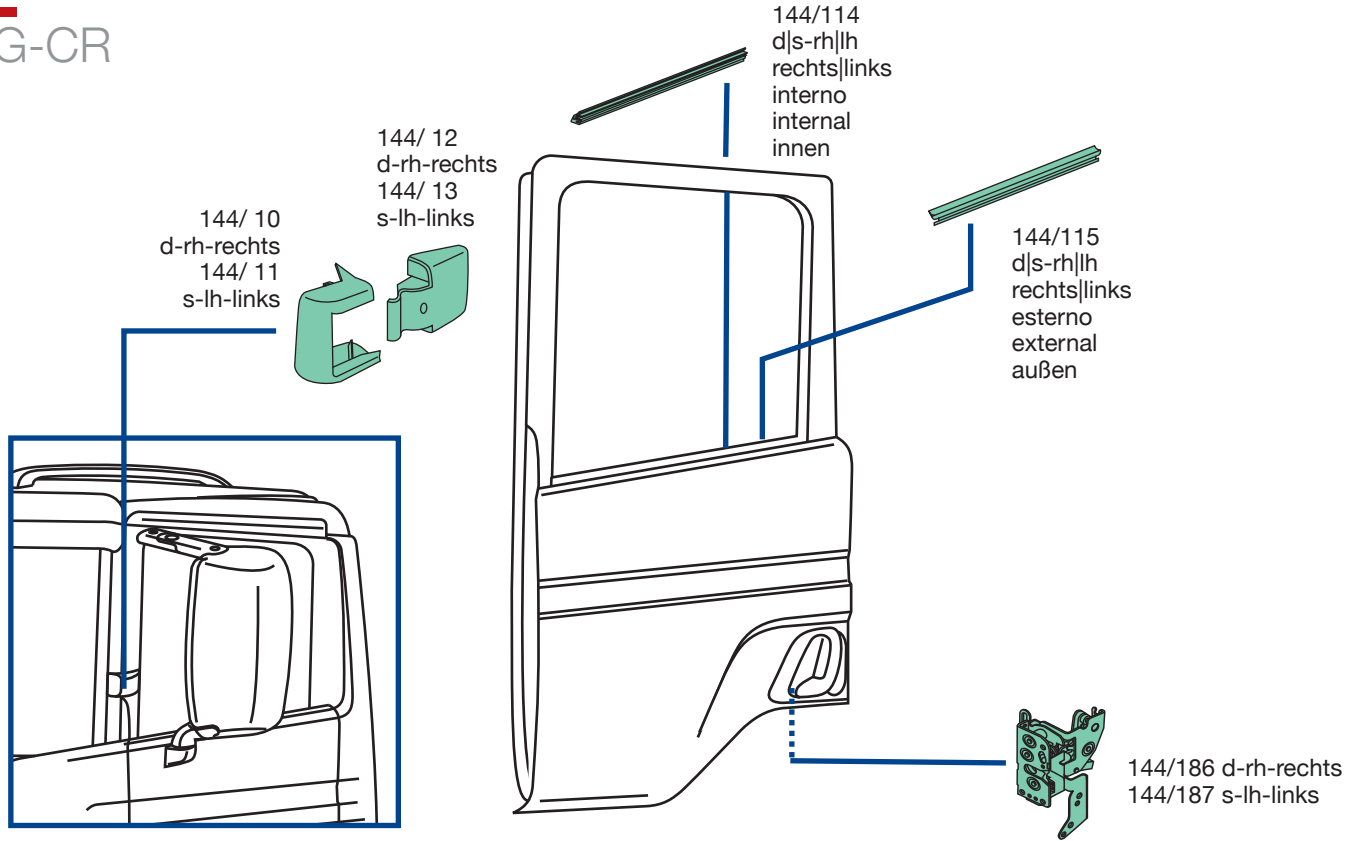

144/10
O.E.M. 1472832
144/11
O.E.M. 1472833



144/12
O.E.M. 1346940
144/13
O.E.M. 1346939



144/114
O.E.M. 1865520

144/115
O.E.M. 1865517



144/186
O.E.M. 1867655
144/187
O.E.M. 1867654

SCANIA R CG-CR

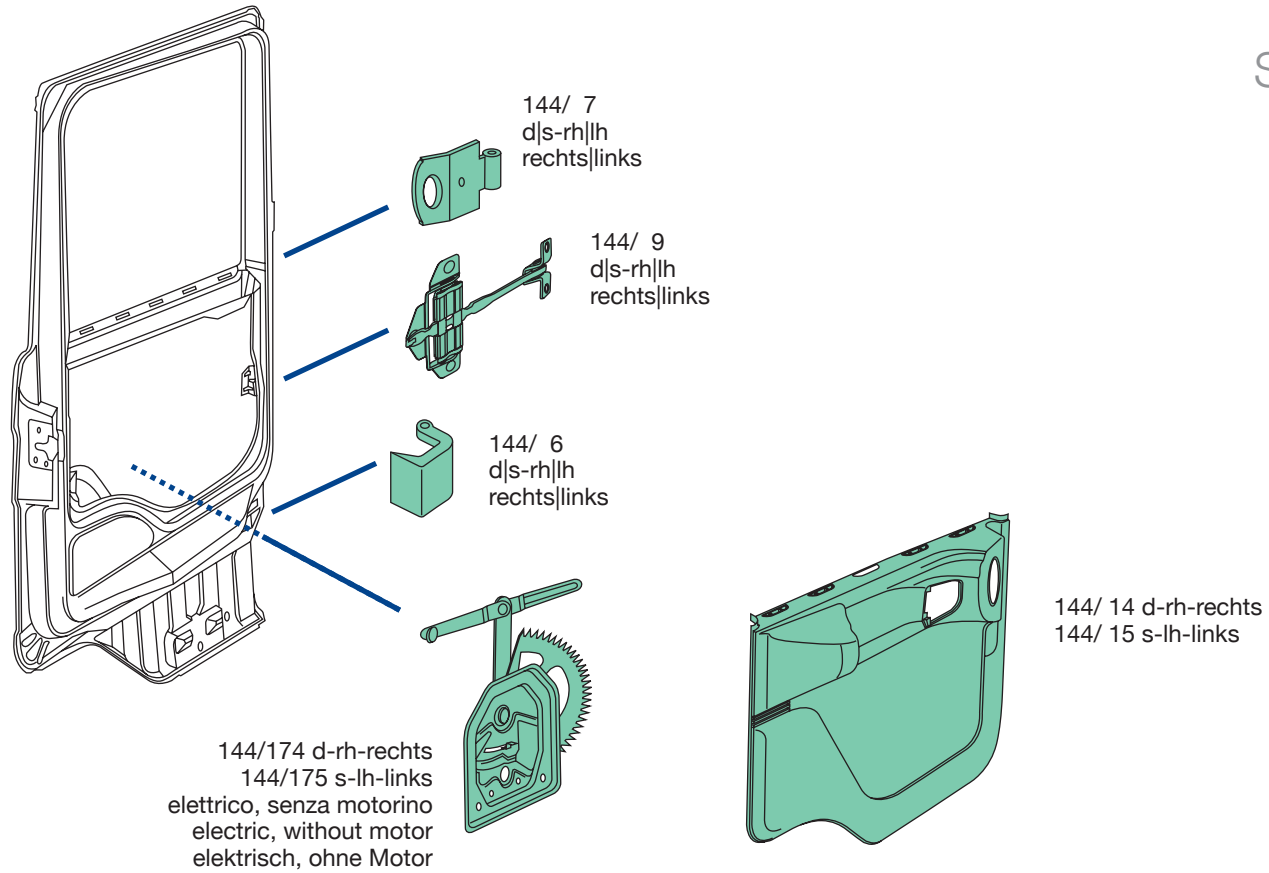

144/ 6
O.E.M. 1426925



144/ 7
O.E.M. 1422292



144/ 9
O.E.M. 1930649



144/ 14
O.E.M. 1346164
144/ 15
O.E.M. 1346163



144/174
O.E.M. 2303352
144/175
O.E.M. 2303349

applicabile a | suitable to | verwendbar für:

SCANIA R CG-CR



144/503



E4 024107

200x432 mm



applicabilità:
applicable to:
Verwendbar für

SCANIA SERIE 4 1996→2004
SCANIA SERIE R/P/T 2004→

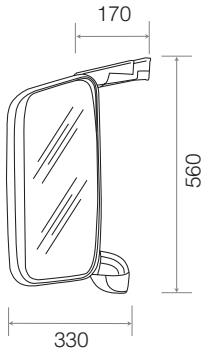

a

-

-

b

144/501

1765985



E4 024107

200x432 mm



d

-

-

f

144/512

1346380



applicabile a | suitable to | verwendbar für:

SCANIA R CG-CR



144/505

2425815
(1723518)



E4 024107

200x432 mm



applicabilità:
applicable to:
Verwendbar für

SCANIA SERIE 4 1996→2004
SCANIA SERIE R/P/T 2004→

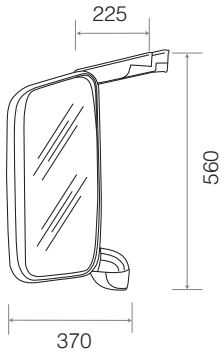

COVIND

II

IV

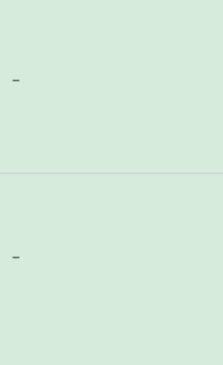

a

-

-

b

144/501

1765985



E4 024107

200x432 mm



d

-

-

f

144/512

1346380



applicabile a | suitable to | verwendbar für:

SCANIA R CG-CR



144/506

2425816
(1723519)



E4 024107

200x432 mm



E4 024108

160x184 mm



applicabilità:
applicable to:
Verwendbar für

SCANIA SERIE 4 1996→2004
SCANIA SERIE R/P/T 2004→

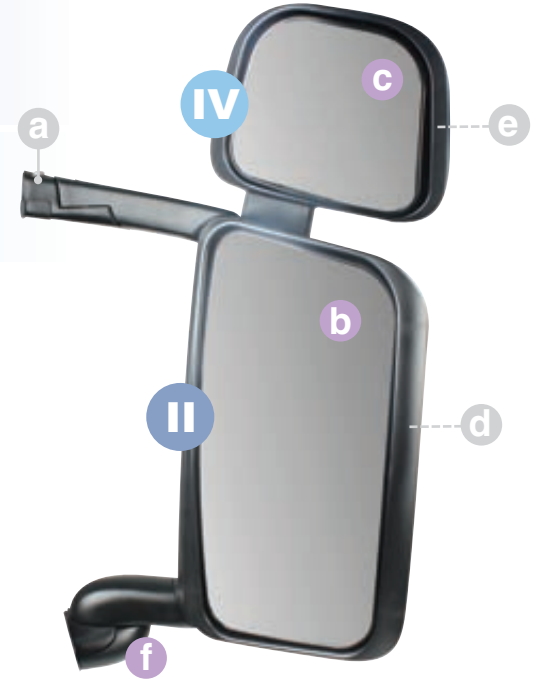
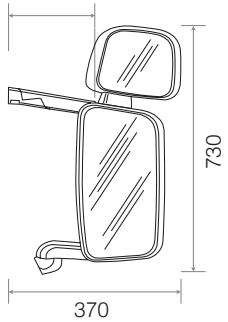

COVIND

144/510

















IV

1765808



260x348 mm

200

a	-	-								
b	144/501 II	1765985							E4 024107	200x432 mm
c	144/502 IV	1767265							E4 024108	160x184 mm
d	-	-								
e	-	-								
f	144/512	1346380								

applicabile a | suitable to | verwendbar für:

SCANIA R CG-CR



144/507

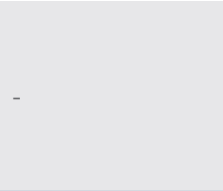

II

E4 024107

200x432 mm



IV

E4 024108

184x160 mm



applicabilità:
applicable to:
Verwendbar für

SCANIA SERIE 4 1996→2004
SCANIA SERIE R/P/T 2004→

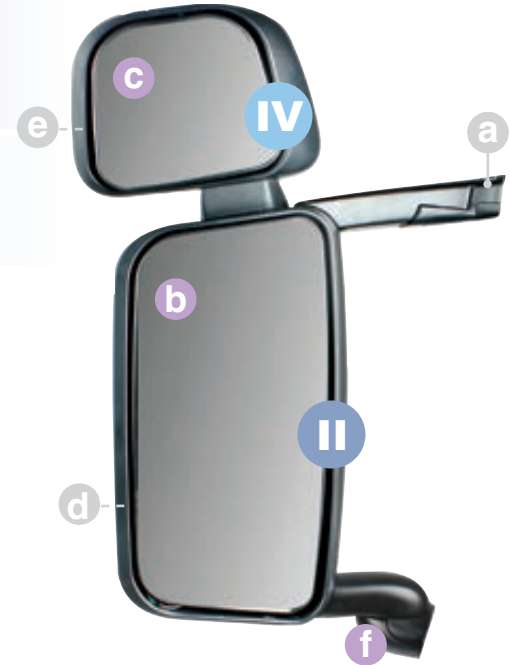
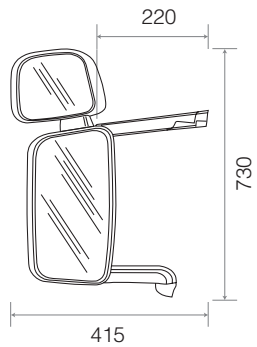

COVIND

















144/511

IV

1765809



260x348 mm

a	-	-								
b	144/501 II	1765985							E4 024107	200x432 mm
c	144/502 IV	1767265							E4 024108	184x160 mm
d	-	-								
e	-	-								
f	144/512	1346380								

applicabile a | suitable to | verwendbar für:

SCANIA R CG-CR



144/508



II (E4) 024107
200x432 mm



IV (E4) 024108
184x160 mm

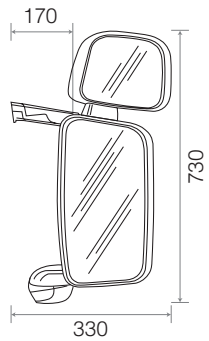

applicabilità:
applicable to:
Verwendbar für

SCANIA SERIE 4 1996→2004
SCANIA SERIE R/P/T 2004→

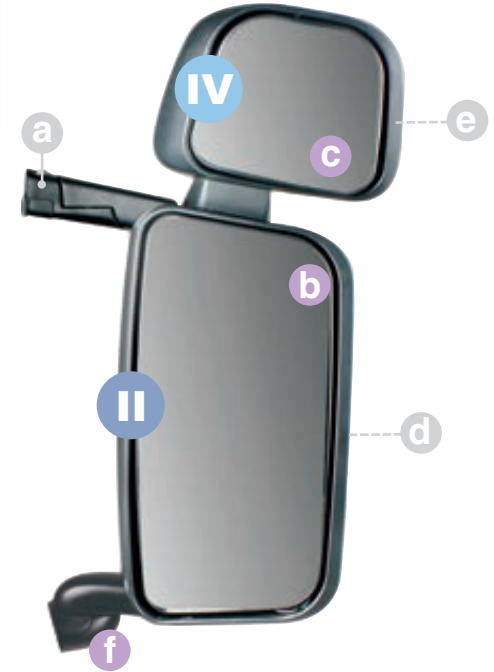

COVIND

144/510

1765808



260x348 mm

IV

a

-

-

b

144/501

1765985



E4 024107

200x432 mm

II

c

144/502

1767265



E4 024108

184x160 mm

IV

d

-

-

e

-

-

f

144/512

1346380



applicabile a | suitable to | verwendbar für:

SCANIA R CG-CR



144/509



II (E4)024107
200x432 mm



IV (E4)024108
184x160 mm

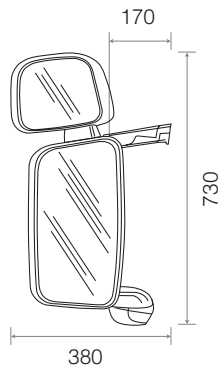

applicabilità:
applicable to:
Verwendbar für

SCANIA SERIE 4 1996→2004
SCANIA SERIE R/P/T 2004→

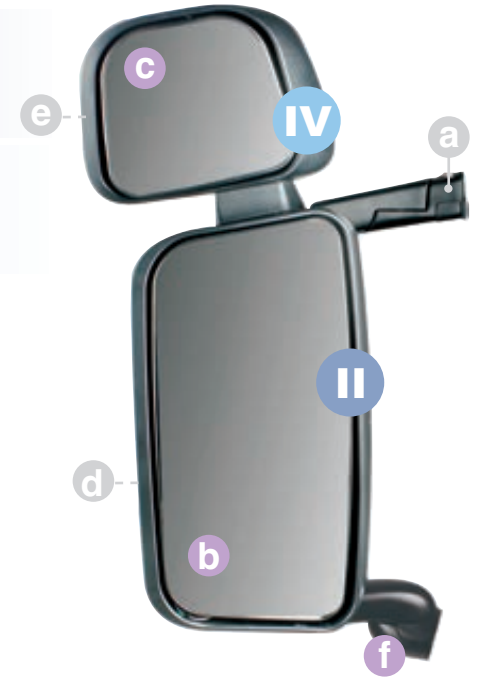

COVIND

144/511

1765809



260x348 mm

IV

a	-	-							
b	144/501 II	1765985							E4 024107 200x432 mm
c	144/502 IV	1767265							E4 024108 184x160 mm
d	-	-							
e	-	-							
f	144/512	1346380							

applicabile a | suitable to | verwendbar für:

SCANIA R CG-CR

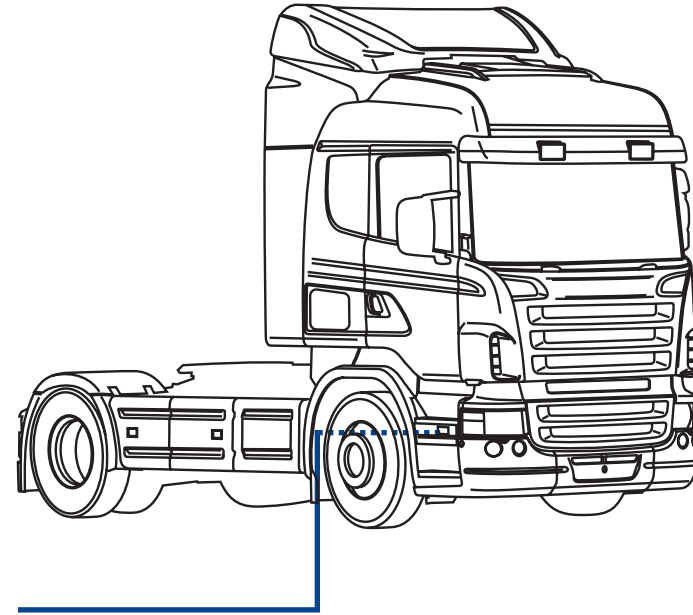
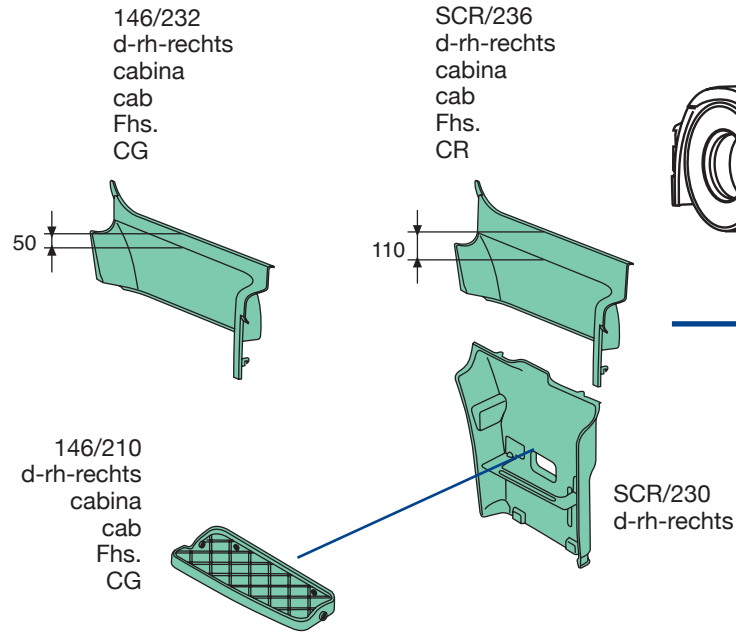

146/210
O.E.M. 1779114



146/232
O.E.M. 1805342



SCR/230
O.E.M. 1854228



SCR/236
O.E.M. 1442654

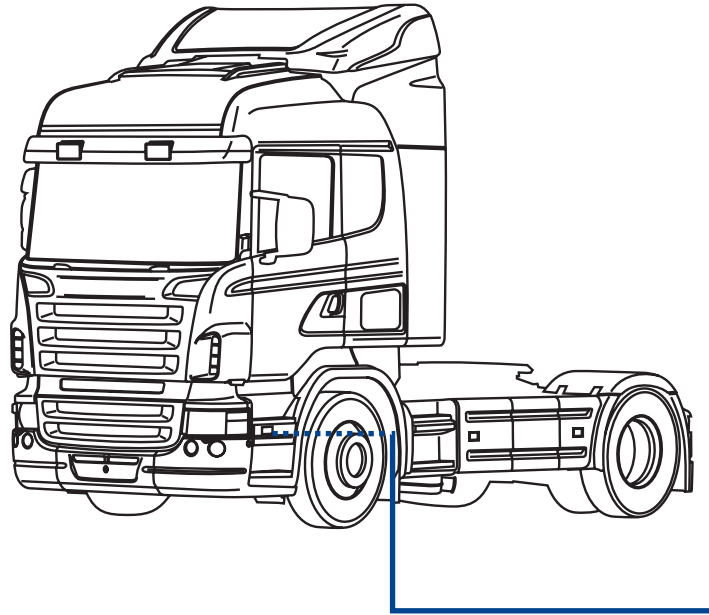

SCR/237
s-lh-links
cabina
cab
Fhs.
CR

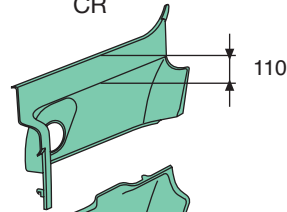

146/233
s-lh-links
cabina
cab
Fhs.
CG

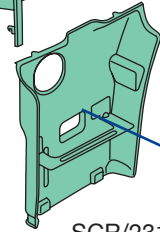
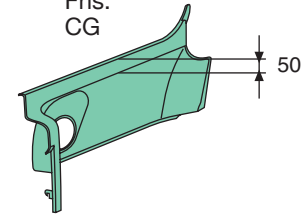

SCR/231
s-lh-links

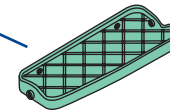

146/211
s-lh-links
cabina
cab
Fhs.
CG

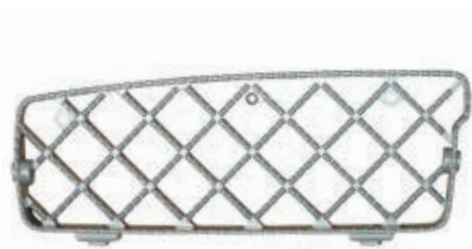

146/211
O.E.M. 1779113



146/233
O.E.M. 1805341



SCR/231
O.E.M. 1854227



SCR/237
O.E.M. 1442653

applicabile a | suitable to | verwendbar für:

SCANIA R CG-CR

SCR/506
d|s-rh||h-rechts|links
segnalatore laterale (3 led)
side marker (3 led)
Seiten markierung (3 led)

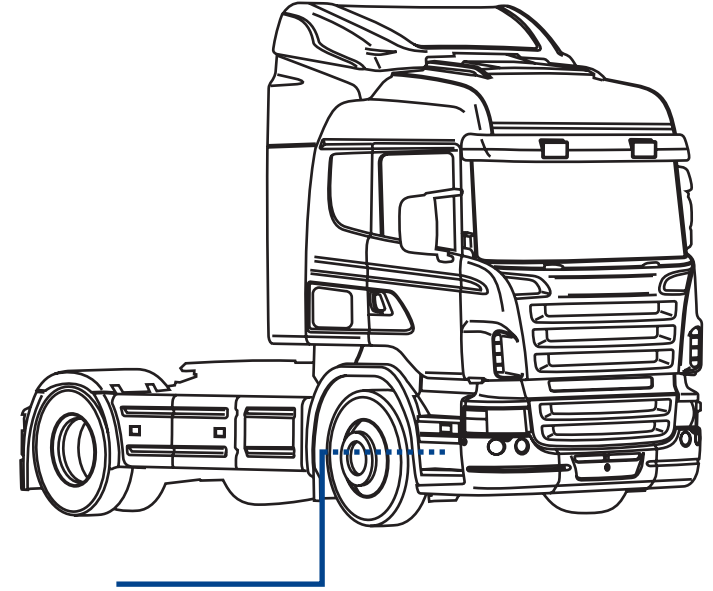
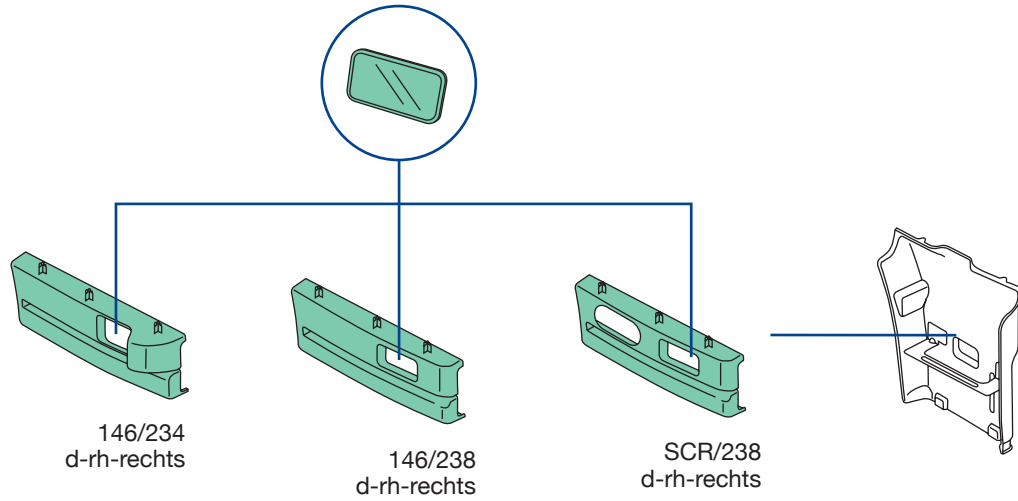

146/234
O.E.M. 1779121



146/238
O.E.M. 1787895



SCR/238
O.E.M. 1779119

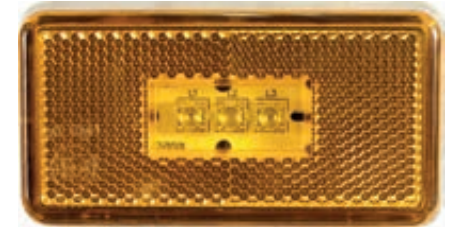

SCR/506
O.E.M. 2080828

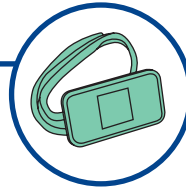
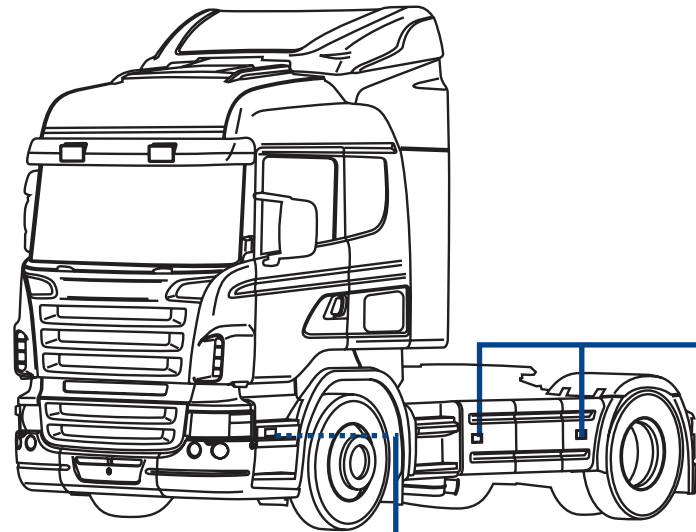

SCR/235
d|s-rh||lh-rechts|links
segnalatore laterale (4 led)
side marker (4 led)
Seiten markierung (4 led)

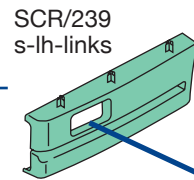
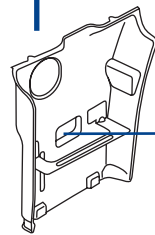

SCR/239
s-lh-links

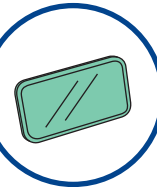

SCR/505
d|s-rh||lh-rechts|links
segnalatore laterale
(a lampadina)
side marker
(with bulb)
Seiten markierung
(mit Glühbirne)

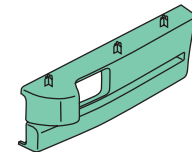

146/235
s-lh-links



146/235
O.E.M. 1779120



SCR/239
O.E.M. 1779118



SCR/235
O.E.M. -

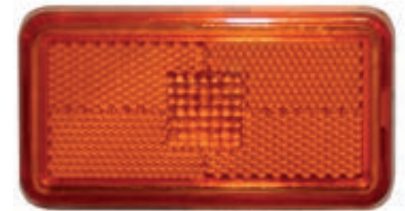

SCR/505
O.E.M. 1362707

applicabile a | suitable to | verwendbar für:

SCANIA R CG-CR

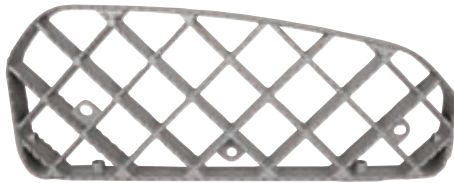
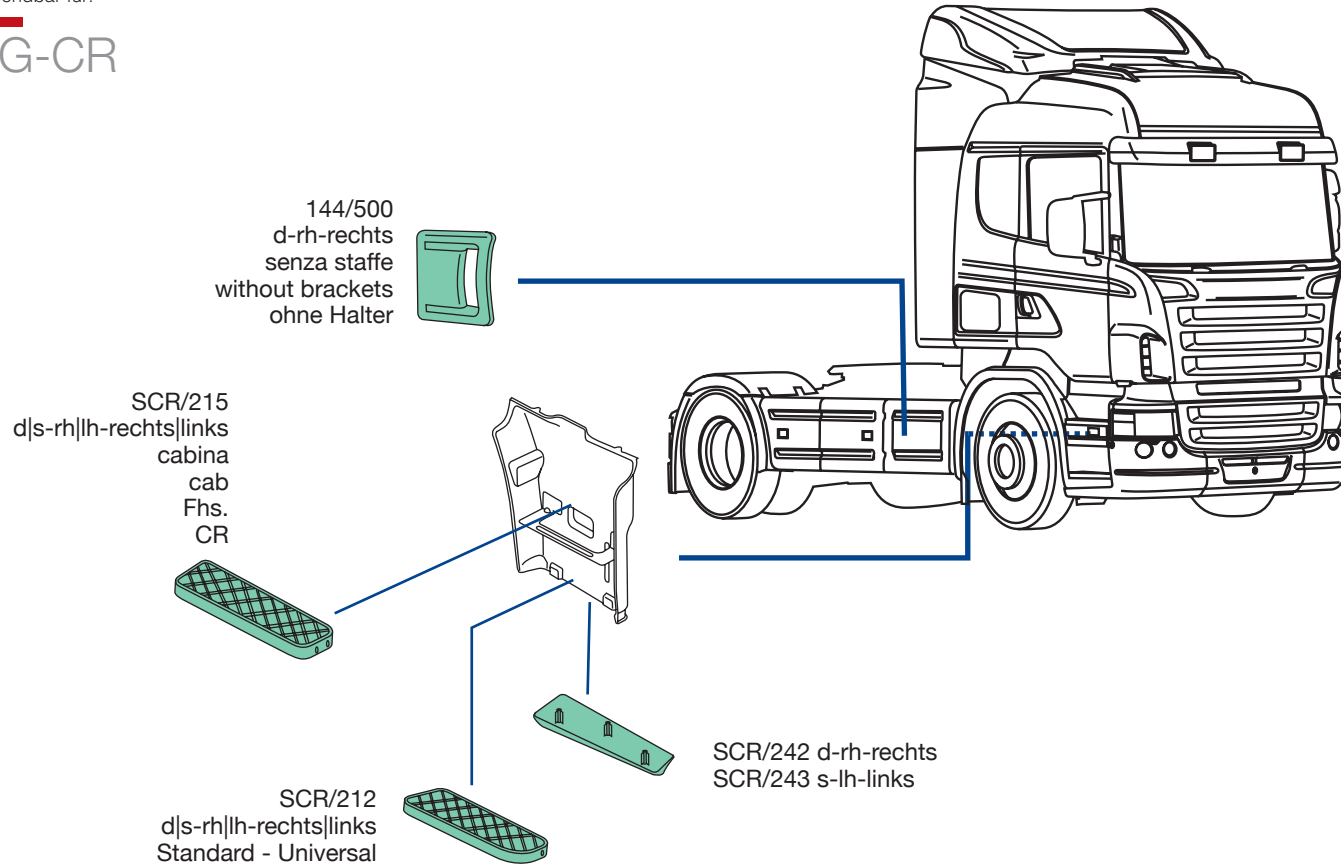

SCR/212
O.E.M. 1535052

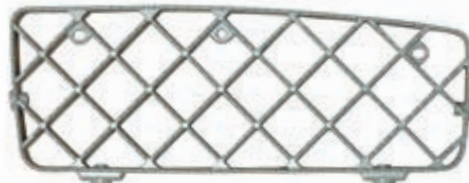

SCR/215
O.E.M. 1805447



SCR/242
O.E.M. 1512424
SCR/243
O.E.M. 1512423



144/500
O.E.M. 1496659

PDS/360

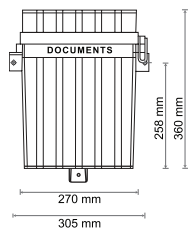

applicabile a | suitable to | verwendbar für:

SCANIA R CG-CR

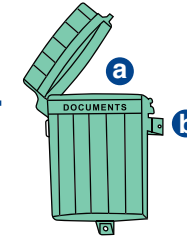
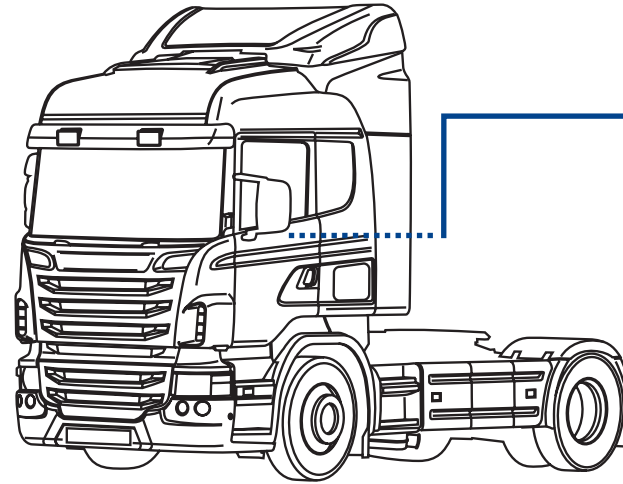

PDS/360



PDS/360
O.E.M. -



applicabile a | suitable to | verwendbar für:

SCANIA R CG-CR

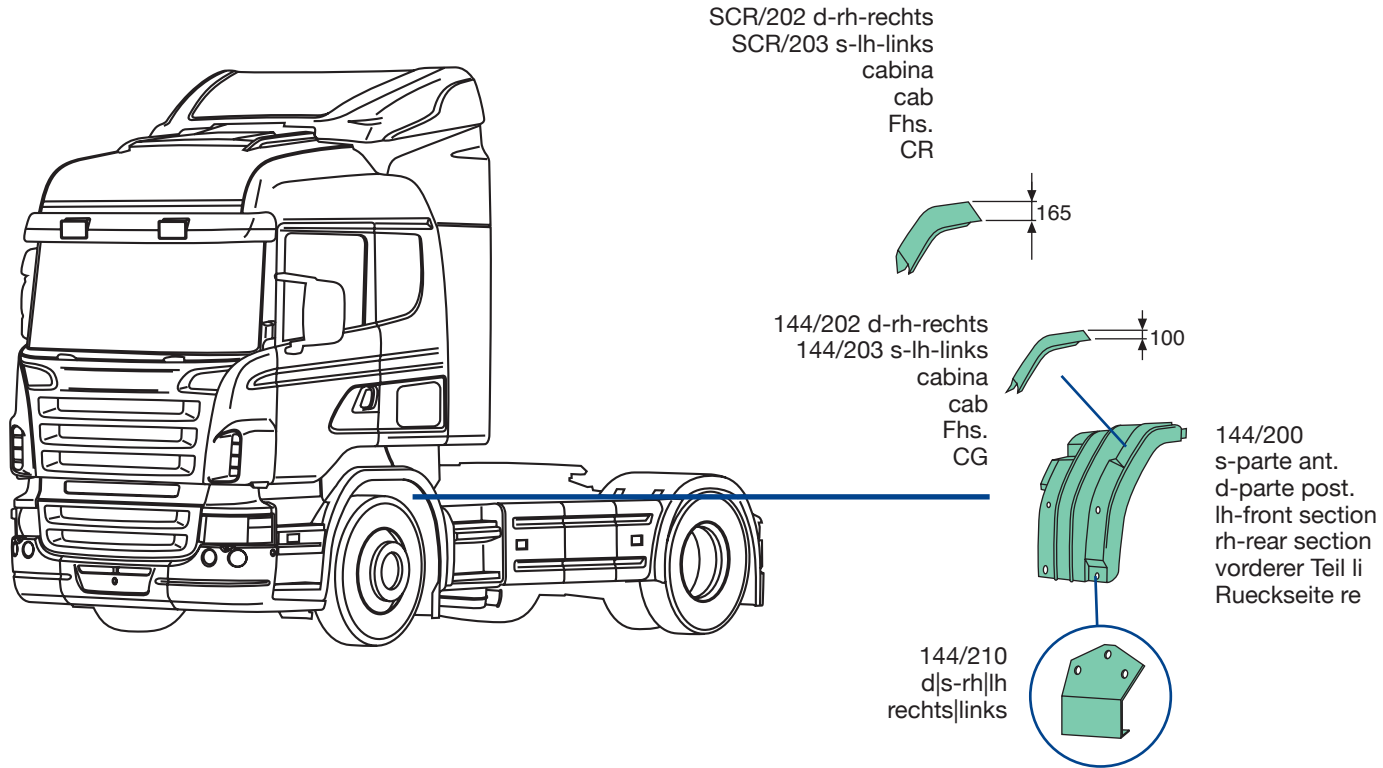

144/200
O.E.M. 1485485



144/202
O.E.M. 1517650
144/203
O.E.M. 1517649



144/210
O.E.M. 1398873



SCR/202
O.E.M. 1431932
SCR/203
O.E.M. 1431931

SCANIA R CG-CR

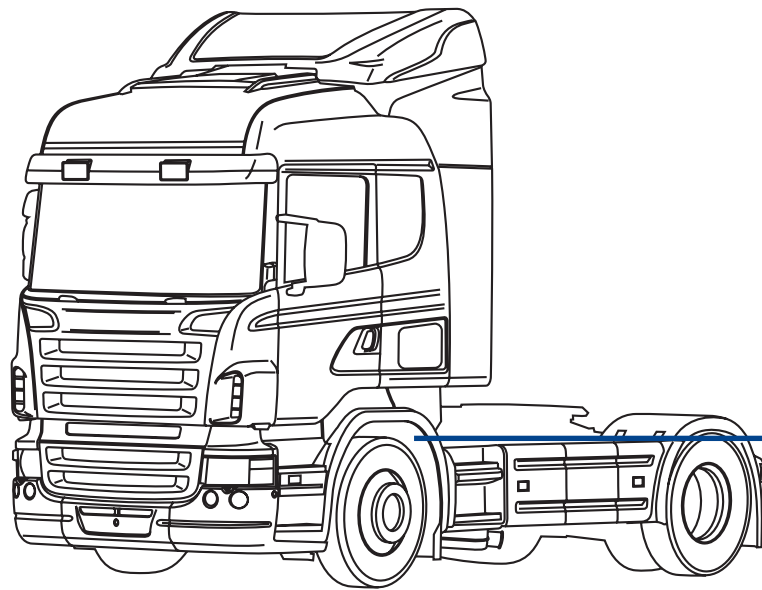

144/220
d|s-rh|lh
rechts|links

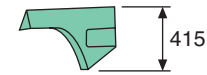
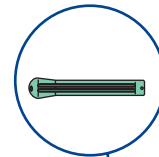

SCR/206 d-rh-rechts
SCR/207 s-lh-links
cabina
cab
Fhs.
CR



144/206 d-rh-rechts
144/207 s-lh-links
cabina
cab
Fhs.
CG

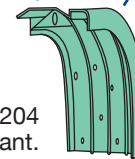

144/204
d-parte ant.
s-parte post.
rh-front section
lh-rear section
vorderer Teil re
Rueckseite li



144/204
O.E.M. 1485486



144/206
O.E.M. 1364666
144/207
O.E.M. 1364665



144/220
O.E.M. 1479924



SCR/206
O.E.M. 1431934
SCR/207
O.E.M. 1431933

applicabile a | suitable to | verwendbar für:

SCANIA R CG-CR

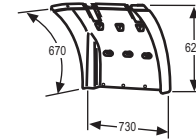
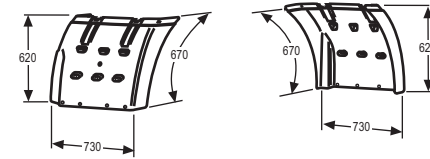
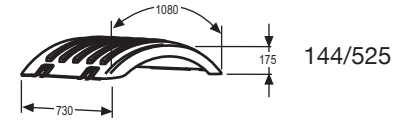
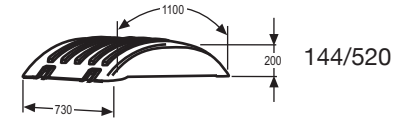
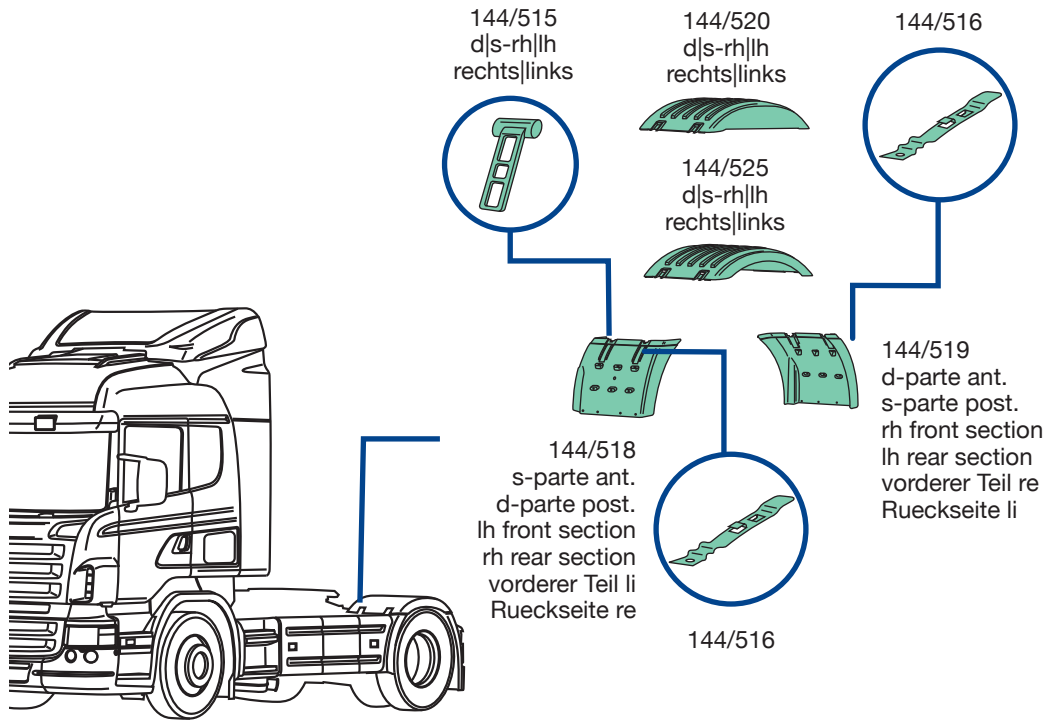

144/515
O.E.M. 1383858



144/516
O.E.M. 2056867

144/520
 O.E.M. 1357601
 d|s-rh|lh-rechts|links
 grigio, circolare, senza cinghietti
 grey, circular, without stretchers
 grau, halbrund, ohne Spanngummi



144/519
 O.E.M. 1357599
 d|s-rh|lh-rechts|links
 grigio, senza anti-spray
 grey, without anti-spray
 grau, ohne Spritzschutz



144/518
 O.E.M. 1357600
 d|s-rh|lh-rechts|links
 grigio
 grey
 grau

144/525
 O.E.M. 1395276
 d|s-rh|lh-rechts|links
 grigio, semipiatta, senza cinghietti
 grey, semi-flat, without stretchers
 grau, halbfach, ohne Spanngummi



144/519

144/518

applicabile a | suitable to | verwendbar für:

SCANIA R CG-CR

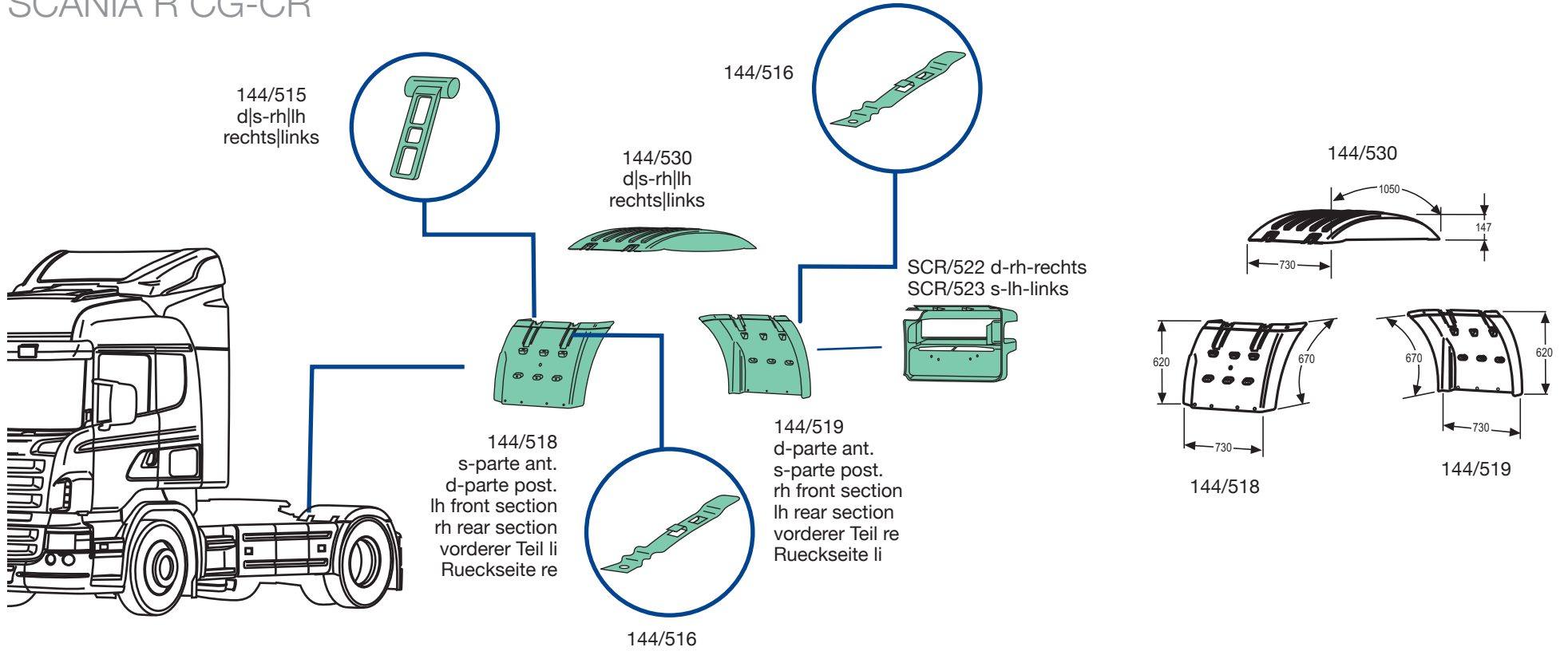

144/515
O.E.M. 1383858



144/516
O.E.M. 2056867



SCR/522
O.E.M. 2026621
SCR/523
O.E.M. 1362708

144/530
 O.E.M. 1357602
 d|s-rh|lh-rechts|links
 grigio, piatta, senza cinghietti
 grey, flat, without stretchers
 grau, flach, ohne Spanngummi

144/519
 O.E.M. 1357599
 d|s-rh|lh-rechts|links
 grigio, senza anti-spray
 grey, without anti-spray
 grau, ohne Spritzschutz

144/518
 O.E.M. 1357600
 d|s-rh|lh-rechts|links
 grigio
 grey
 grau



applicabile a | suitable to | verwendbar für:

SCANIA R CG-CR

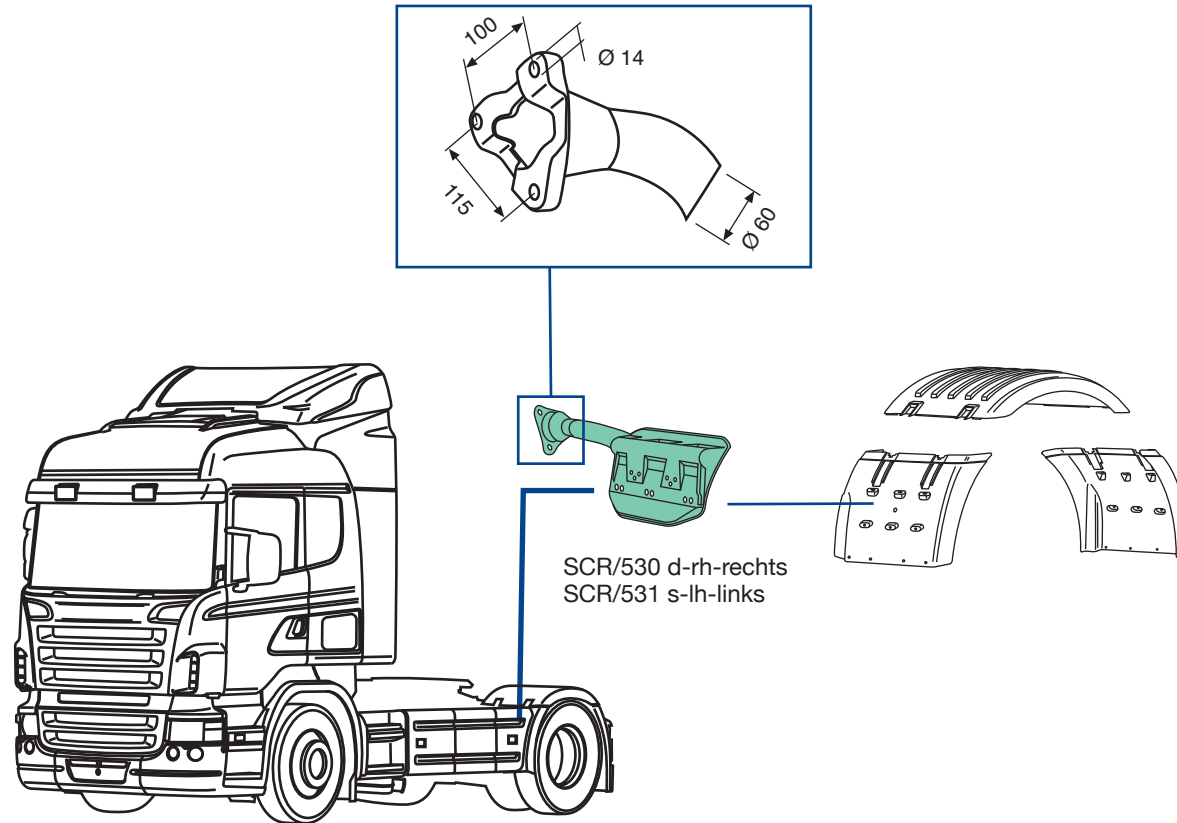



SCR/530
O.E.M. 2054582
anteriore destro
front right
vorne rechts

SCR/531
O.E.M. 2054581
anteriore sinistro
front left
vorne links

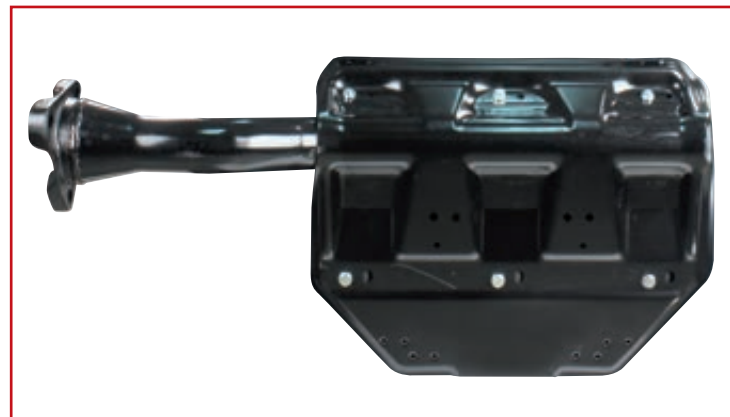
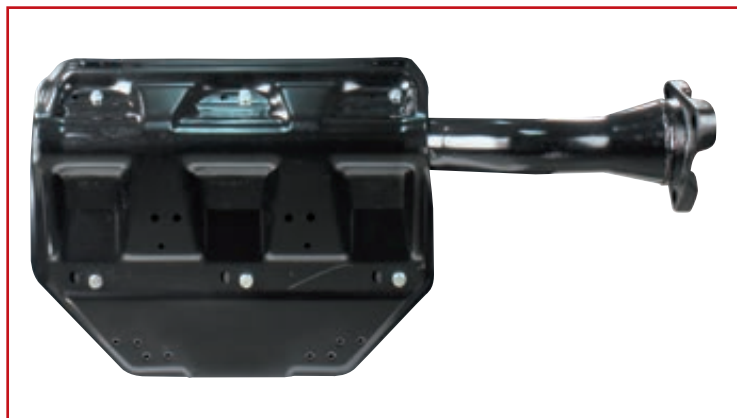

applicabile a | suitable to | verwendbar für:

SCANIA R CG-CR

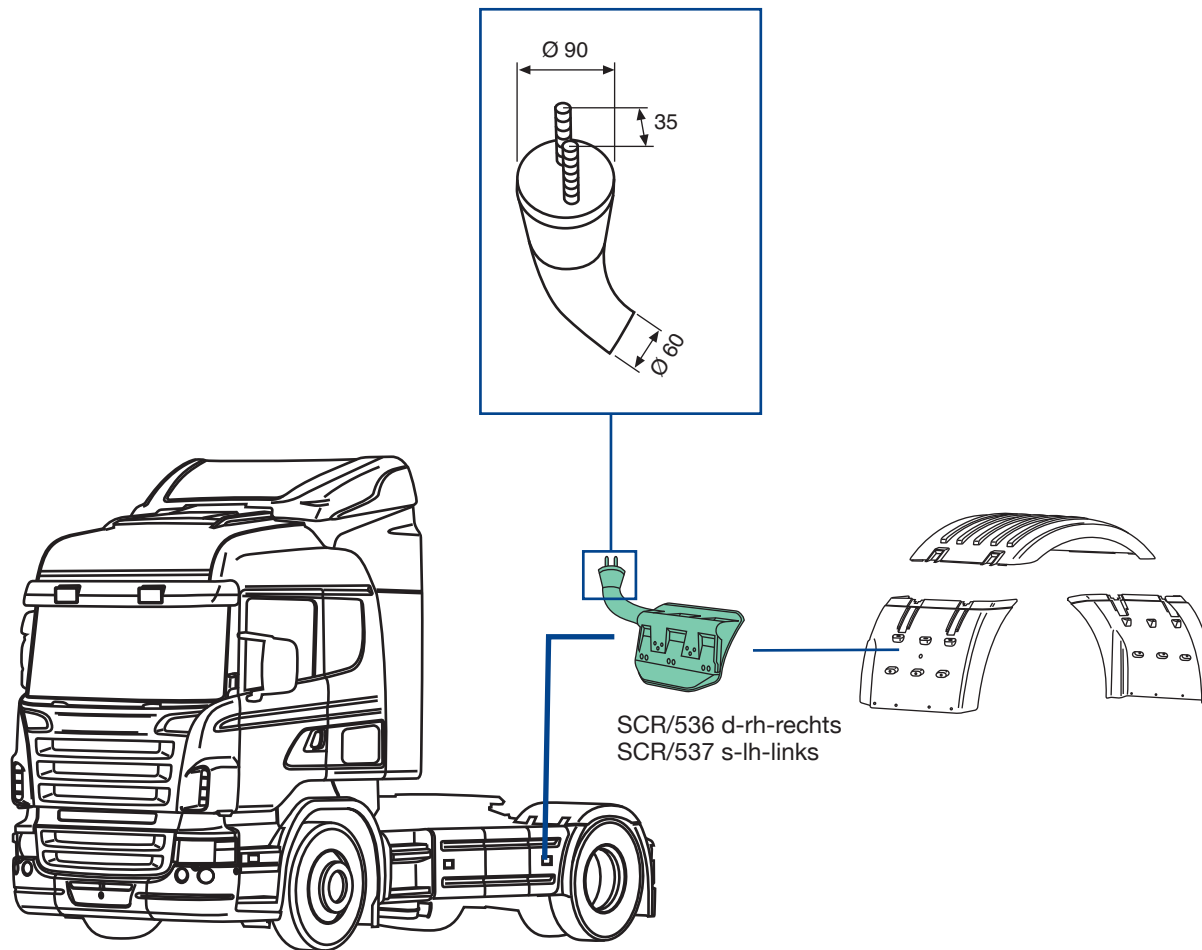



SCR/536
O.E.M. 1457920
anteriore destro
front right
vorne rechts

SCR/537
O.E.M. 1457919
anteriore sinistro
front left
vorne links



applicabile a | suitable to | verwendbar für:

SCANIA R CG-CR

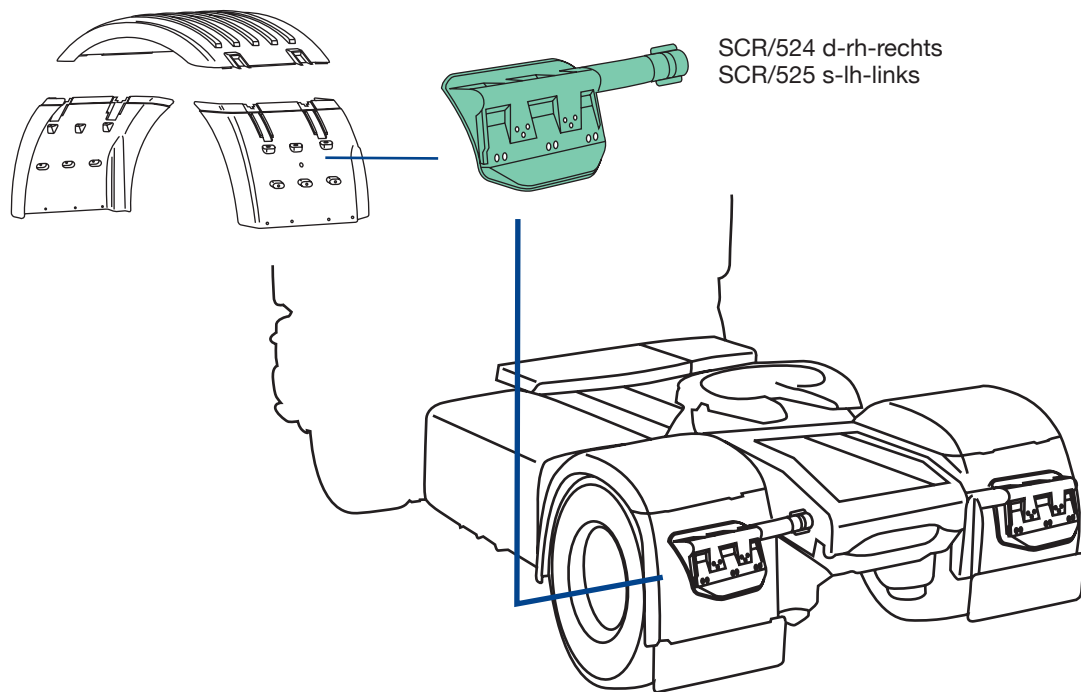



SCR/525
O.E.M. 2054589
posteriore sinistro
rear left
hinten links

SCR/524
O.E.M. 2054590
posteriore destro
rear right
hinten rechts



applicabile a | suitable to | verwendbar für:

SCANIA R CG-CR

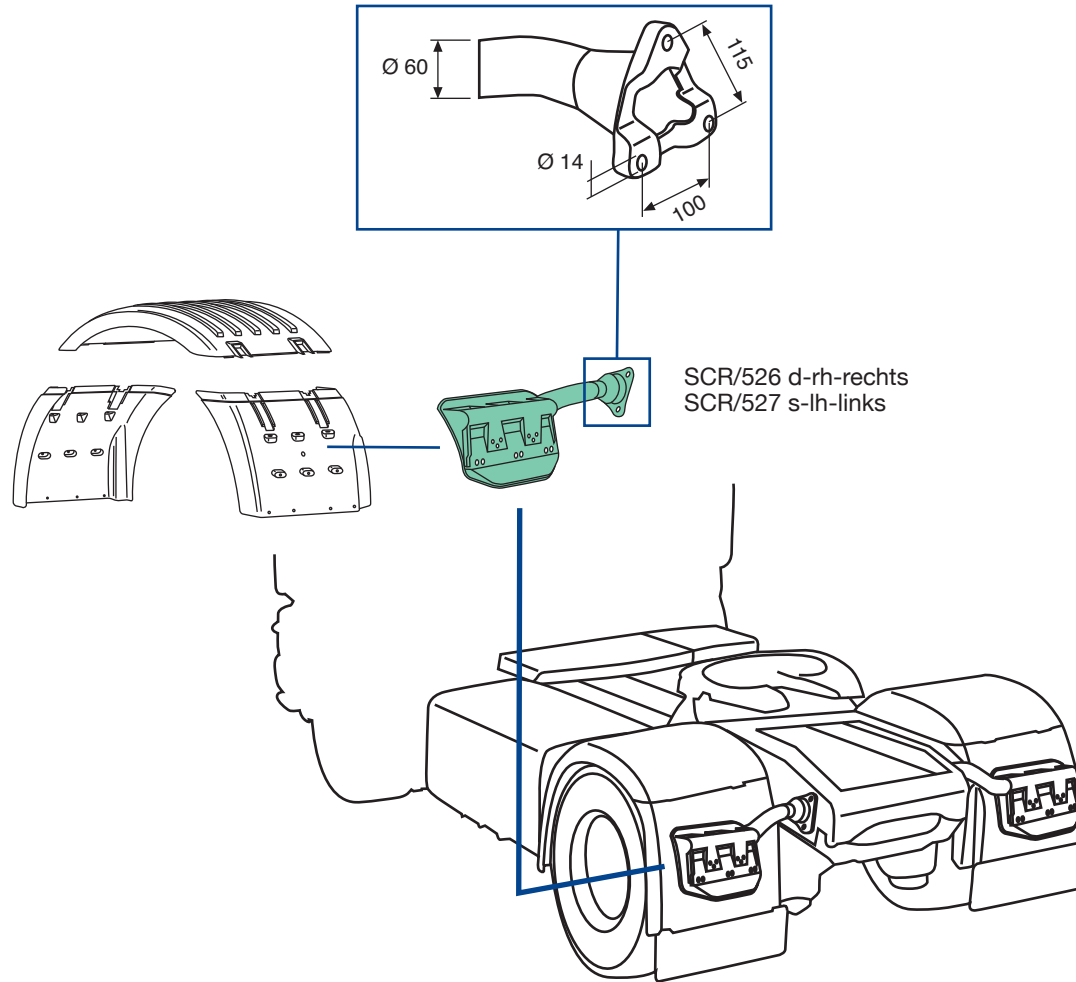



SCR/527
O.E.M. 2054579
posteriore sinistro
rear left
hinten links

SCR/526
O.E.M. 2054580
posteriore destro
rear right
hinten rechts



applicabile a | suitable to | verwendbar für:

SCANIA R CG-CR

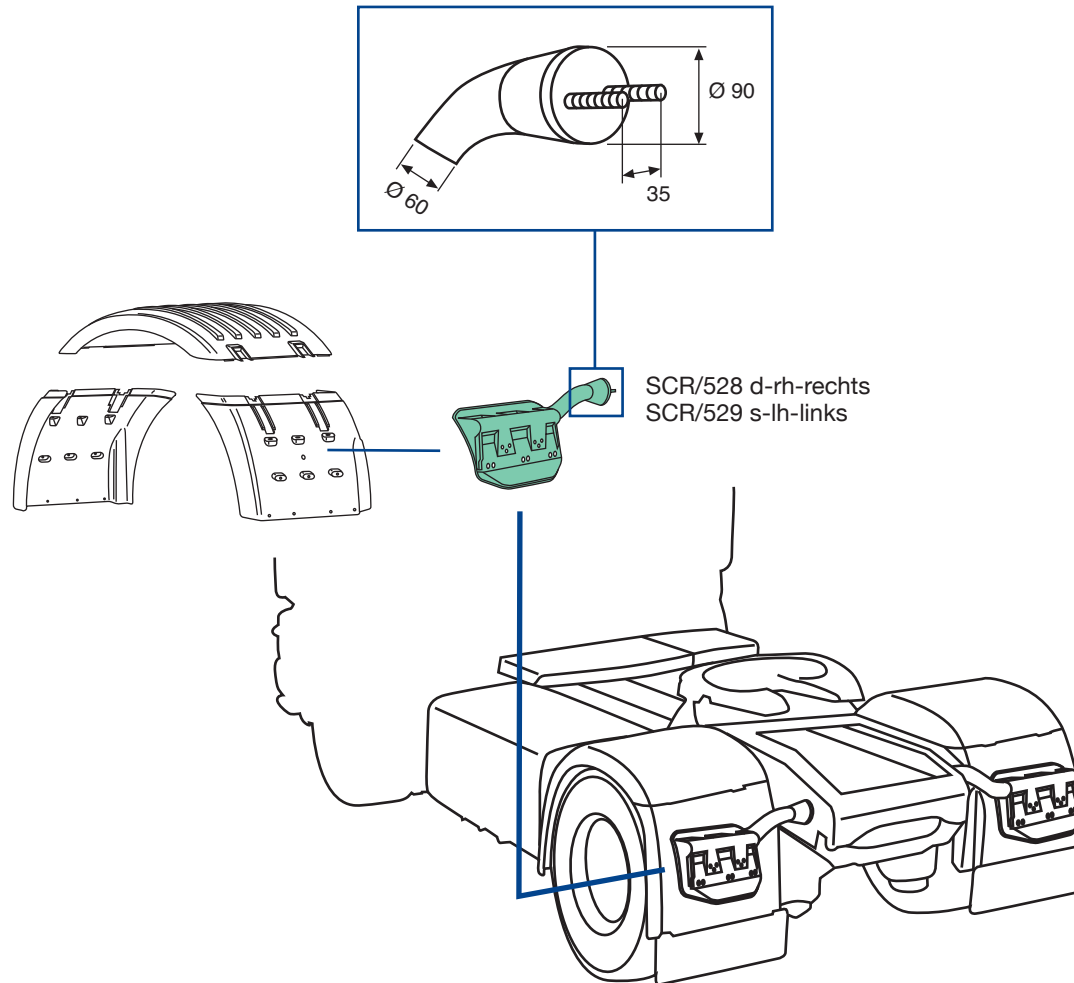



SCR/529
O.E.M. 2054603
posteriore sinistro
rear left
hinten links

SCR/528
O.E.M. 2054604
posteriore destro
rear right
hinten rechts



applicabile a | suitable to | verwendbar für:

SCANIA R CG-CR

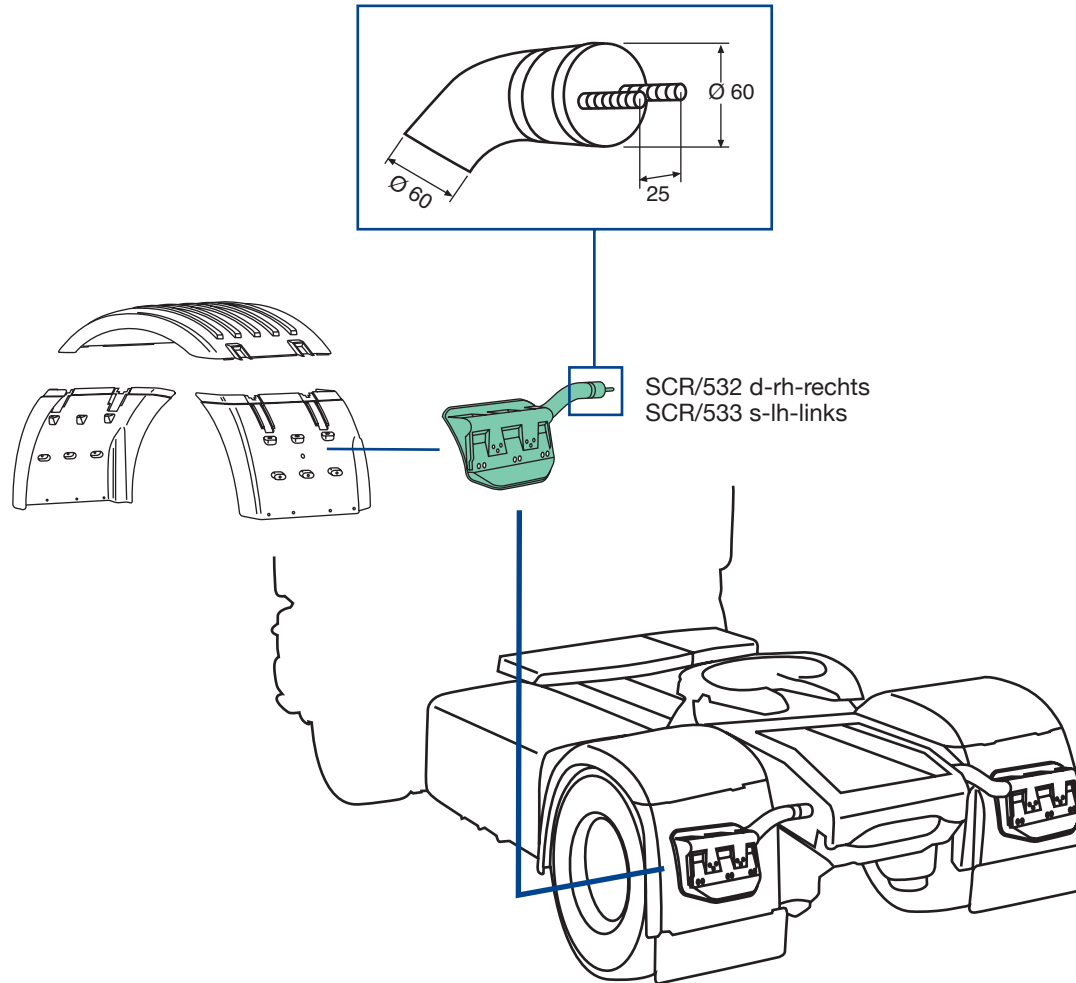



SCR/533
O.E.M. 1457929
posteriore sinistro
rear left
hinten links

SCR/532
O.E.M. 1457930
posteriore destro
rear right
hinten rechts



applicabile a | suitable to | verwendbar für:

SCANIA R CG-CR

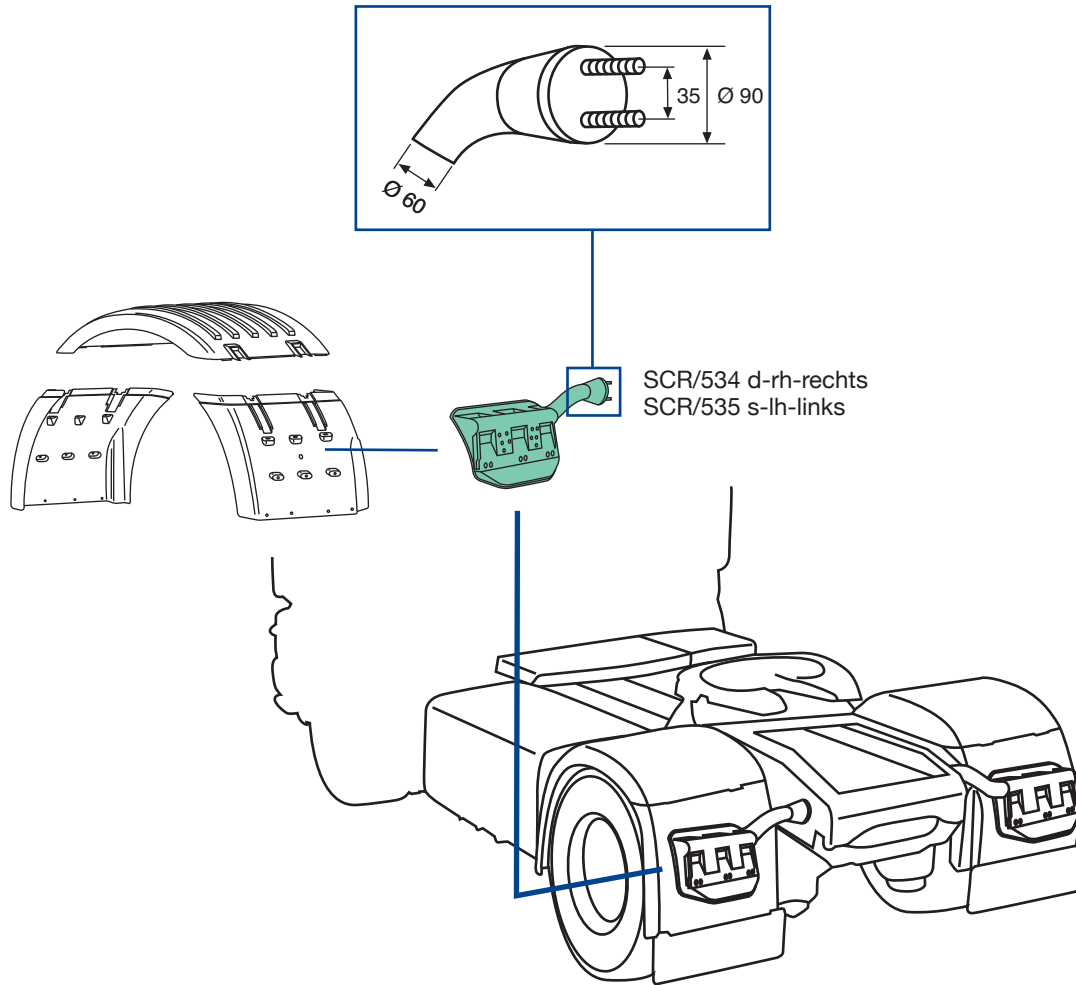



SCR/535
O.E.M. 2054601
posteriore sinistro
rear left
hinten links

SCR/534
O.E.M. 2054602
posteriore destro
rear right
hinten rechts



applicabile a | suitable to | verwendbar für:

SCANIA R CG-CR

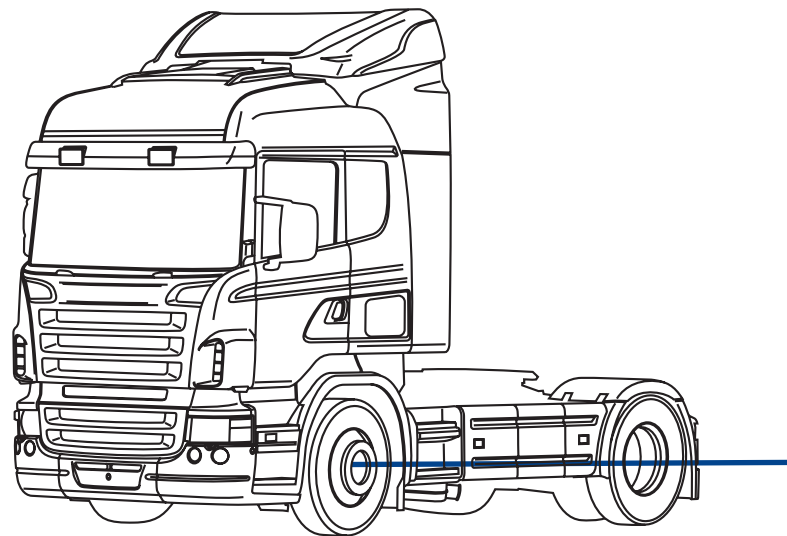

930/033

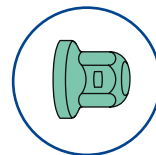

930/100
d-rh-rechts
930/101
s-lh-links

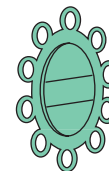

930/001
d-rh-rechts
930/002
s-lh-links

930/200
d|s-rh|lh
rechts|links



930/033
O.E.M. -



930/001
O.E.M. -
930/002
O.E.M. -



930/100
O.E.M. -
930/101
O.E.M. -



930/200
O.E.M. -

930/033 - Tappo copri Bullone - Bolt cover - Radmutterkappen

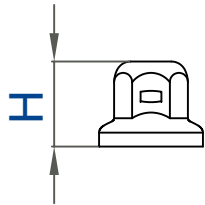

H	45 mm
Per bulloni \varnothing - bolt \varnothing	33 mm
Schlüsselweite \varnothing	
Colore	cromato-chrome-verchromt
Colours-Farbe	
Materiale-Material	acciaio inox-stainless steel Edelstahl
Kg	0,025

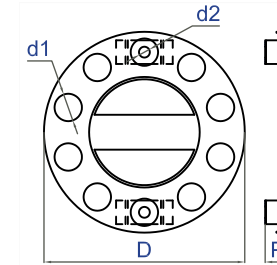

930/001 d-rh-rechts - 930/002 s-lh-links

D \varnothing 425 mm	P 50 mm
d1 nr. 10	d1 \varnothing 58 mm
d2 nr. 2	d2 \varnothing 23 mm
Ventilata	si-yes-Ja
Ventilated-Belüftet	
Colore	cromato e nero-chrome and black
Colours-Farbe	verchromt und schwarz
Materiale-Material	acciaio inox e plastica stainless steel and plastic Edelstahl und Kunststoff
Kg	1,230

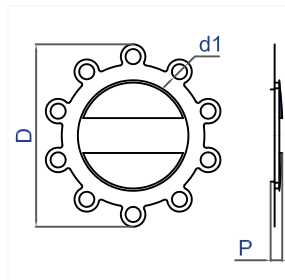

930/100 d-rh-rechts - 930/101 s-lh-links

D \varnothing 387 mm	P 30 mm
d1 nr. 10	d1 \varnothing 32 mm
Ventilata	si-yes-Ja
Ventilated-Belüftet	
Colore	cromato e nero-chrome and black
Colours-Farbe	verchromt und schwarz
Materiale-Material	acciaio inox e plastica stainless steel and plastic Edelstahl und Kunststoff
Kg	0,655

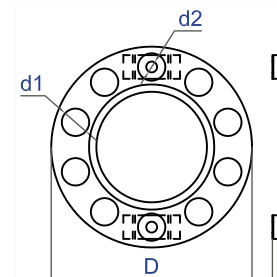

930/200 d|s-rh|lh-rechts|links

D \varnothing 425 mm	P 40 mm
d1 nr. 10	d1 \varnothing 58 mm
d2 nr. 2	d2 \varnothing 23 mm
Ventilata	no-nein
Ventilated-Belüftet	
Colore	cromato-chrome-verchromt
Colours-Farbe	
Materiale-Material	acciaio inox-stainless steel Edelstahl
Kg	1,155

applicabile a | suitable to | verwendbar für:

SCANIA R CG-CR

(*) Completo di staffe e tappo centrale - With central cap and brackets - mit Halter und Abdeckkappe

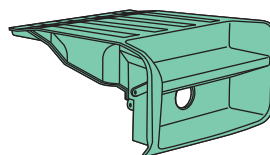
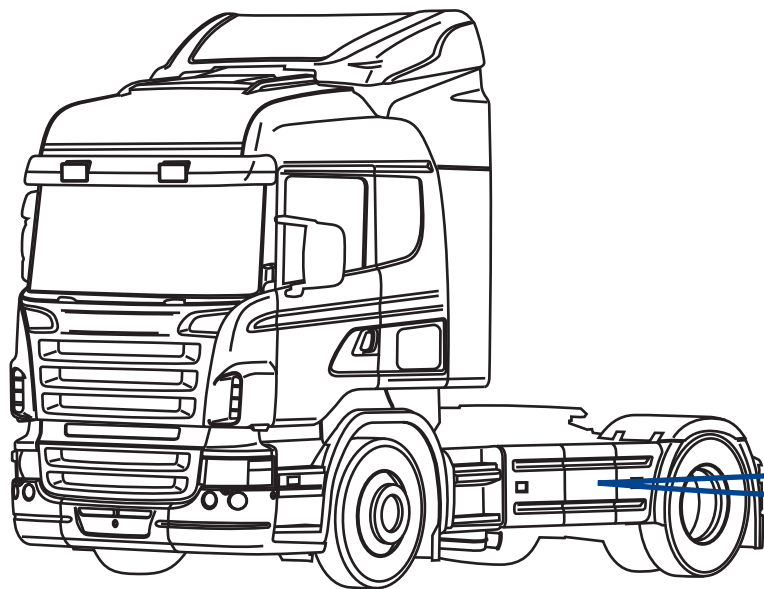

SCR/619

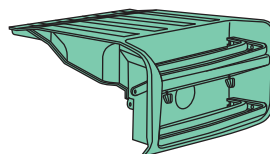

SCR/620(*)
con - with - mit:
1425051 (2 pz.-pcs.-st.) +
1425052 (2 pz.-pcs.-st.) +
1362691



SCR/619
O.E.M. 2093721



SCR/620
O.E.M. 2093720



applicabile a | suitable to | verwendbar für

237

094

SCANIA 94 CP

D CLASS CP94-114-124

I codici originali sono riportati unicamente per favorire l'identificazione del prodotto | The original codes are indicated for product identification only | Die aufgeführten Originalnummer dienen ausschließlich zu Vergleichszwecken

applicabile a | suitable to | verwendbar für:

SCANIA 94 CP

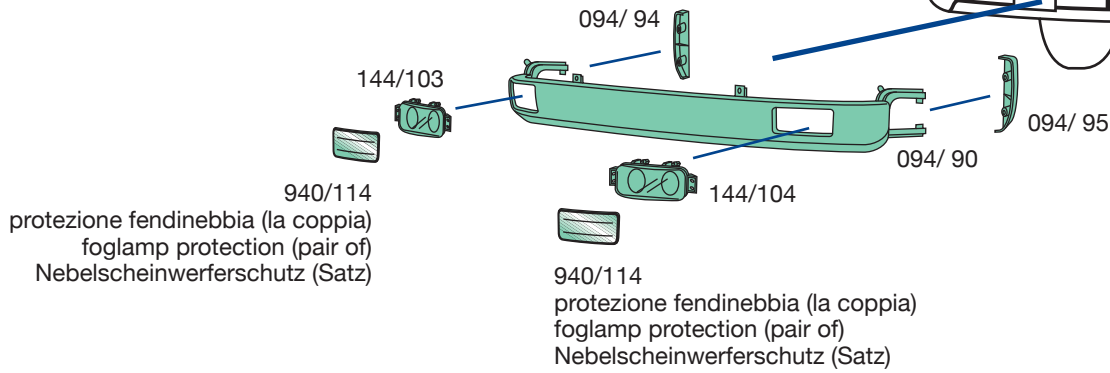
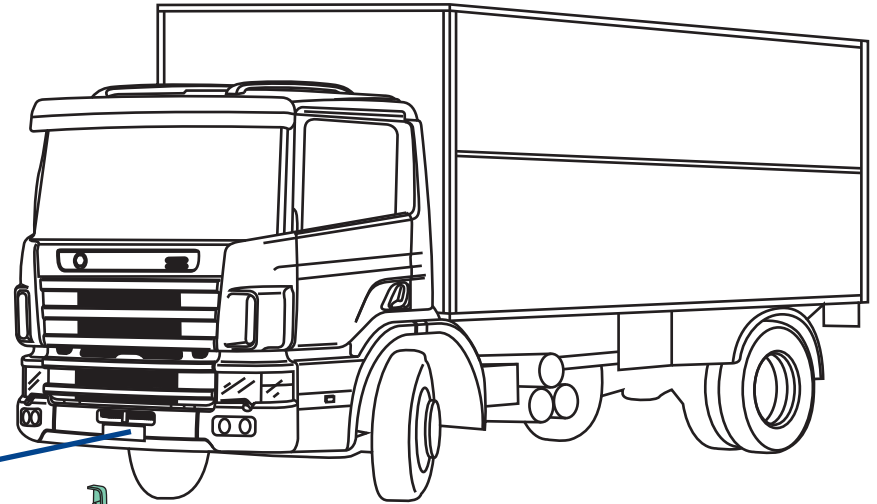

094/90
O.E.M. 1515190



094/94
O.E.M. 1375458
094/95
O.E.M. 1375457



144/103
O.E.M. 1529071
144/104
O.E.M. 1529070



940/114
O.E.M. -

SCANIA 94 CP

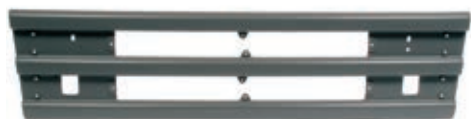
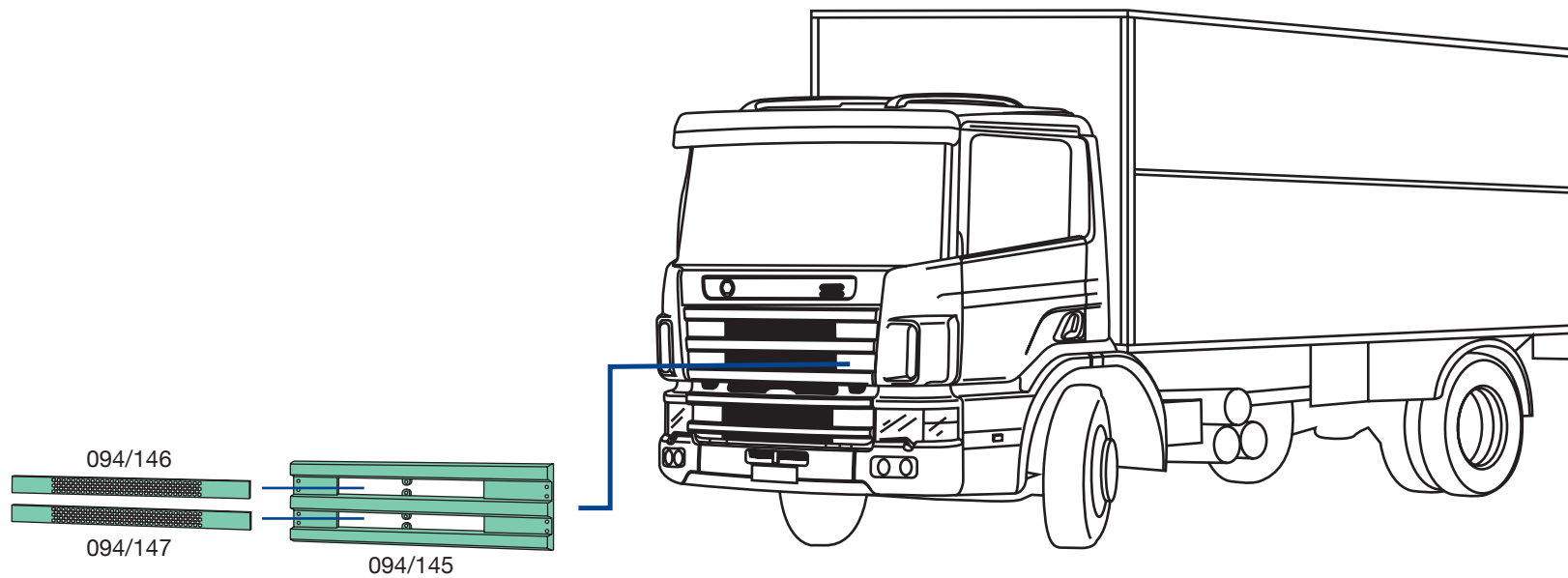

094/145
O.E.M. 1397571



094/146
O.E.M. 1401931



094/147
O.E.M. 1371754

applicabile a | suitable to | verwendbar für:

SCANIA 94 CP

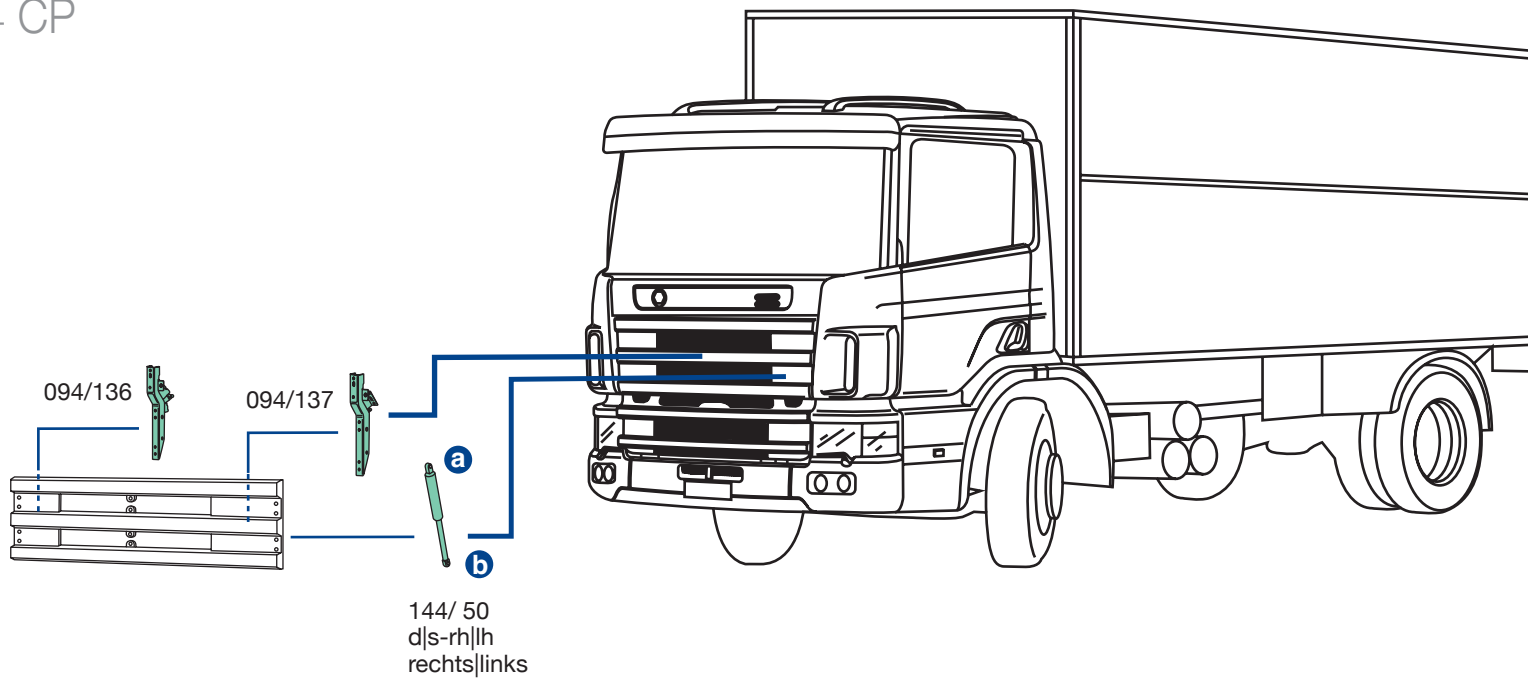

094/136
O.E.M. 1393447
094/137
O.E.M. 1383887



144/ 50
O.E.M. 1306492



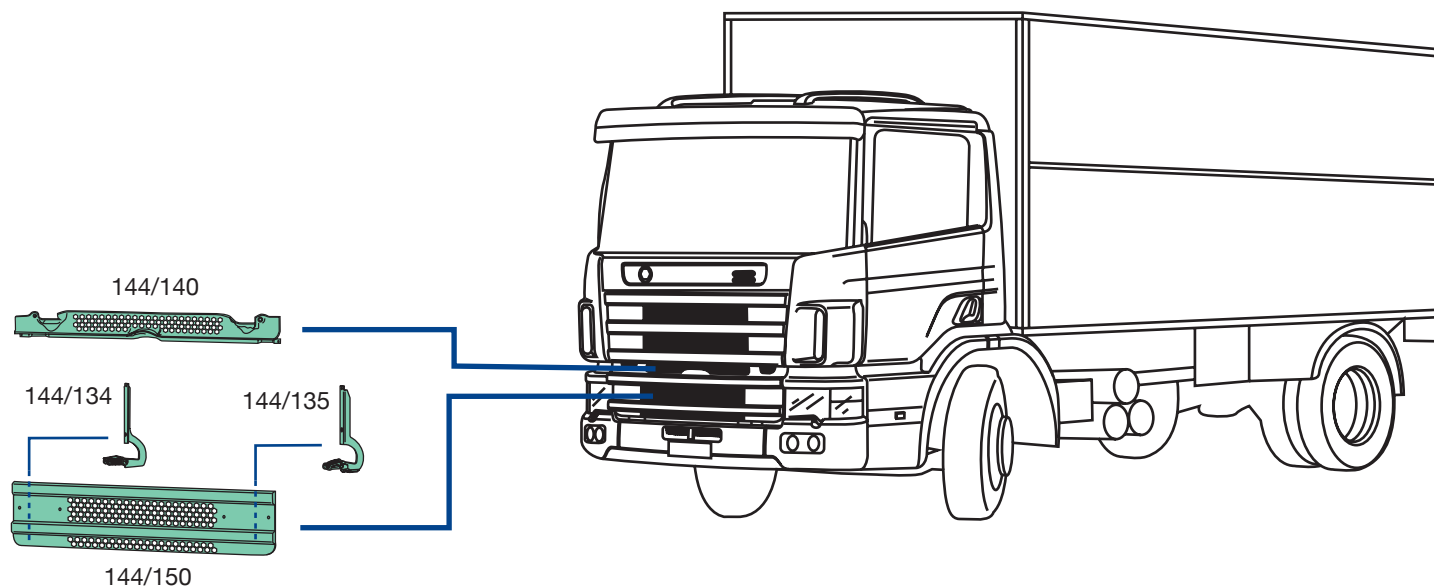

144/134
O.E.M. 1381480
144/135
O.E.M. 1381479



144/140
O.E.M. 1870689



144/150
O.E.M. 1366384

applicabile a | suitable to | verwendbar für:

SCANIA 94 CP

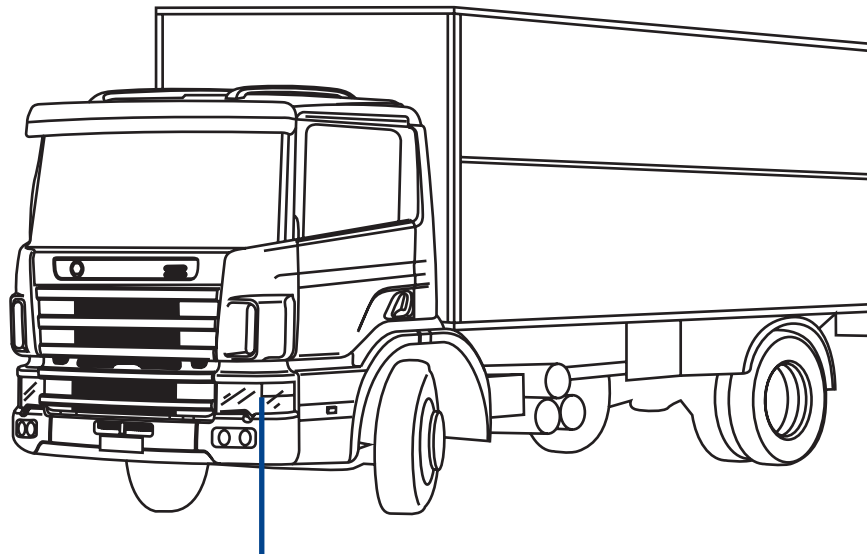

144/101 d-rh-rechts
144/102 s-lh-links
H4, predisposto
per correttore elettrico
H4, suitable
for load level adjustment
H4, verwendbar
für leuchtweiterregelung

940/144
protezione faro (la coppia)
headlamp protection (pair of)
Scheinwerferschutz (Satz)

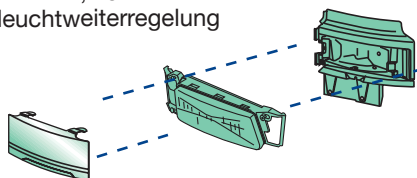

144/154 d-rh-rechts
144/155 s-lh-links



144/101
O.E.M. 1732510
144/102
O.E.M. 1732509



144/154
O.E.M. 1543635
144/155
O.E.M. 1543634



940/144
O.E.M. -

SCANIA 94 CP

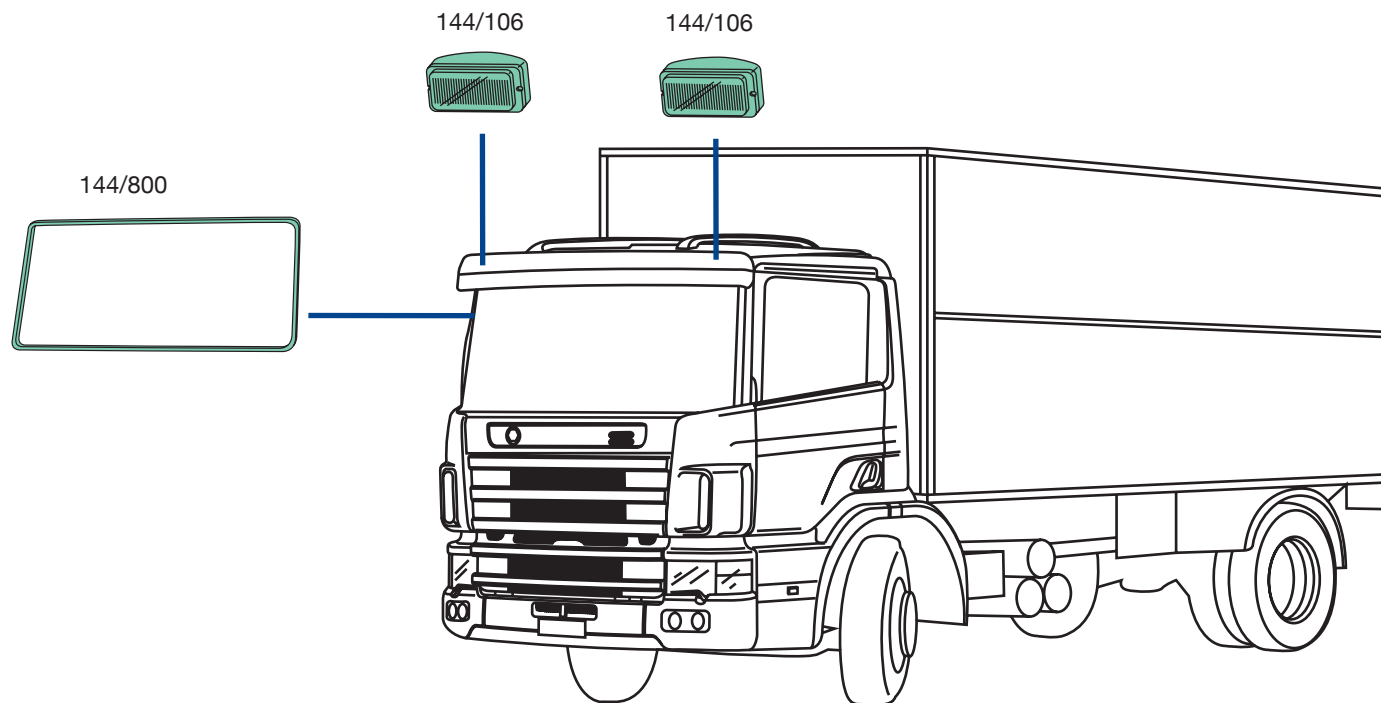

144/106
O.E.M. 1749953



144/800
O.E.M. 1366851

applicabile a | suitable to | verwendbar für:

SCANIA 94 CP

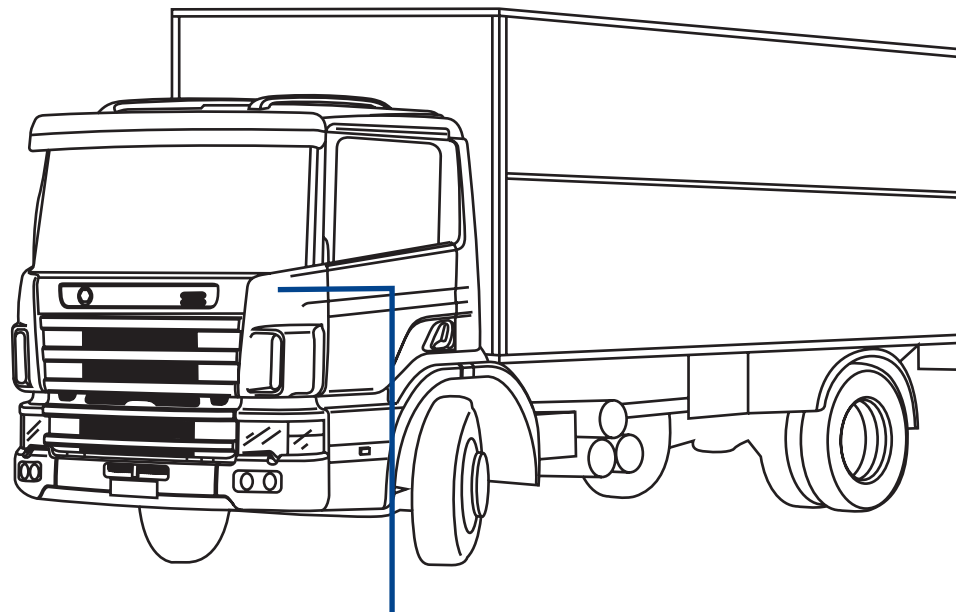

144/158 d-rh-rechts
144/159 s-lh-links

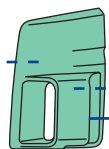

094/164 d-rh-rechts
094/165 s-lh-links

094/160 d-rh-rechts
094/161 s-lh-links



094/162 d-rh-rechts
094/163 s-lh-links



094/160
O.E.M. 1386958
094/161
O.E.M. 1386957



094/162
O.E.M. 1370108
094/163
O.E.M. 1370107



094/164
O.E.M. 1386960
094/165
O.E.M. 1386959



144/158
O.E.M. 1726851
144/159
O.E.M. 1440108

SCP/ 2 d-rh-rechts
SCP/ 3 s-lh-links
lastrata, con cerniere
paneled with hinges
rohbaütür, mit Scharnier

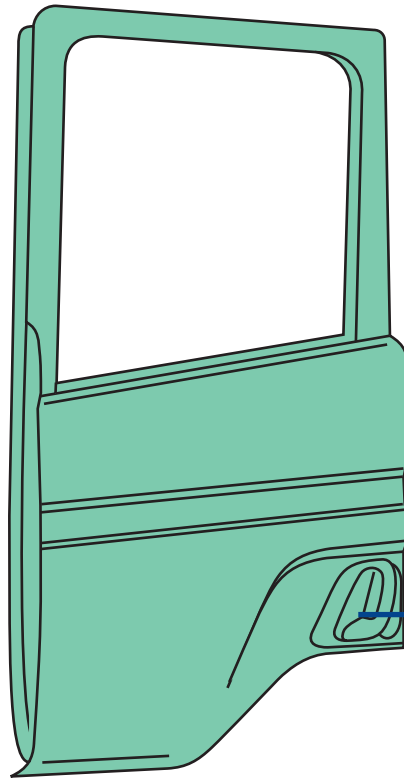

144/194 d-rh-rechts
144/195 s-lh-links

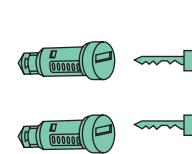
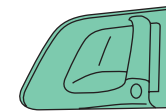
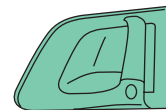

144/196
d|s-rh|lh
rechts|links

SCR/194 d-rh-rechts
SCR/195 s-lh-links



SCP/ 2
O.E.M. 1476533
SCP/ 3
O.E.M. 1476532



144/194
O.E.M. 2145648
144/195
O.E.M. 2145647



144/196
O.E.M. 1485072



SCR/194
O.E.M. -
SCR/195
O.E.M. -

applicabile a | suitable to | verwendbar für:

SCANIA 94 CP

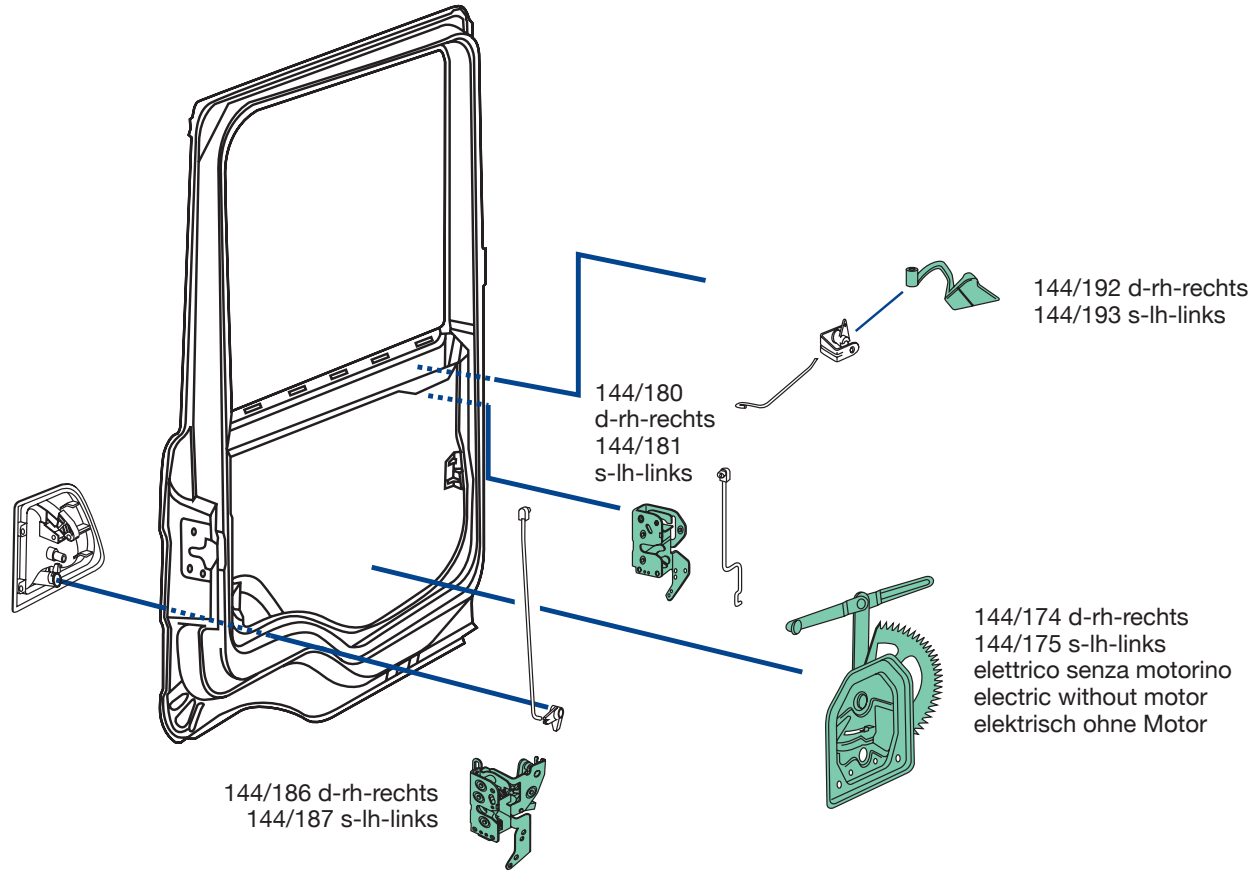

144/174
O.E.M. 2303352
144/175
O.E.M. 2303349



144/180
O.E.M. 1902976
144/181
O.E.M. 1902975



144/186
O.E.M. 1867655
144/187
O.E.M. 1867654



144/192
O.E.M. 1346178
144/193
O.E.M. 1346177

SCANIA 94 CP

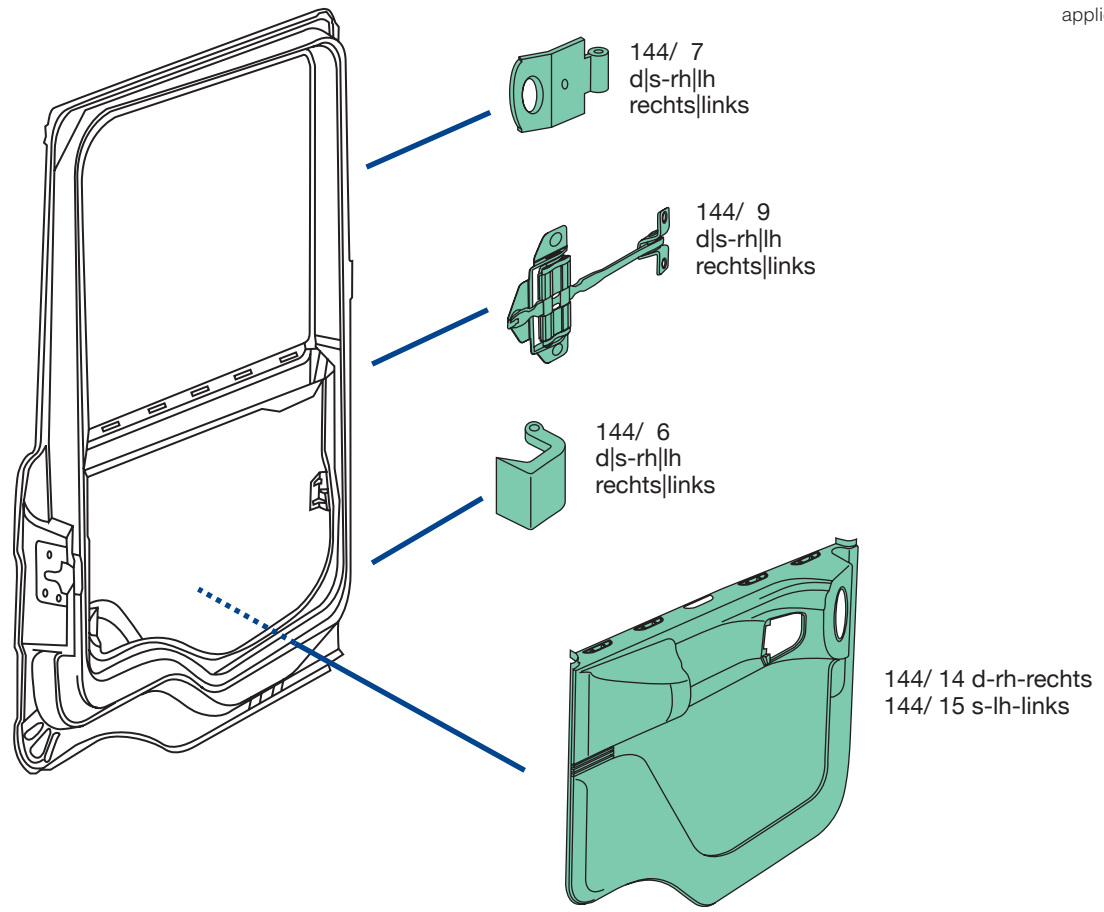

144/ 6
O.E.M. 1426925



144/ 7
O.E.M. 1422292



144/ 9
O.E.M. 1930649



144/ 14
O.E.M. 1346164
144/ 15
O.E.M. 1346163

applicabile a | suitable to | verwendbar für:

SCANIA 94 CP



144/503



E4 024107

200x432 mm



applicabilità:
applicable to:
Verwendbar für

SCANIA SERIE 4 1996→2004
SCANIA SERIE R/P/T 2004→

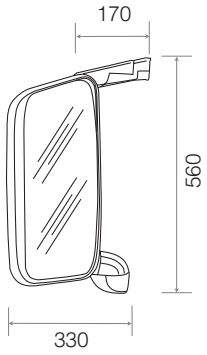

a

-

-

b

144/501

1765985



E4 024107

200x432 mm



d

-

-

f

144/512

1346380



applicabile a | suitable to | verwendbar für:

SCANIA 94 CP



144/505

2425815
(1723518)



E4 024107

200x432 mm

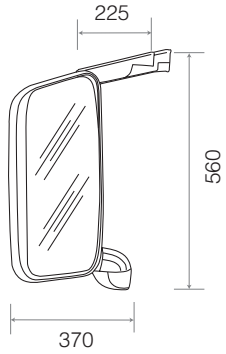

applicabilità:
applicable to:
Verwendbar für

SCANIA SERIE 4 1996→2004
SCANIA SERIE R/P/T 2004→



COVIND

II

IV

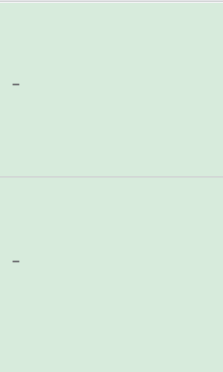

250

a

-

-

b

144/501

1765985



E4 024107

200x432 mm



d

-

-

f

144/512

1346380



applicabile a | suitable to | verwendbar für:

SCANIA 94 CP



144/506

2425816
(1723519)



E4 024107

200x432 mm



E4 024108

160x184 mm



applicabilità:
applicable to:
Verwendbar für

SCANIA SERIE 4 1996→2004
SCANIA SERIE R/P/T 2004→

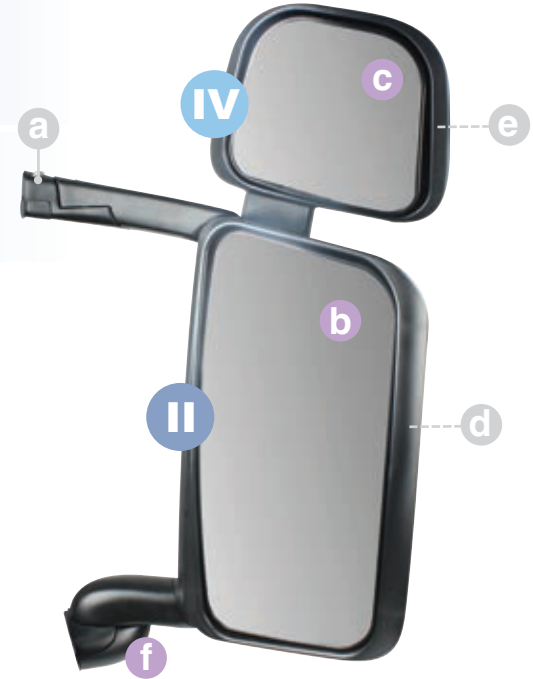
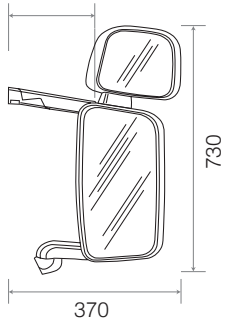

COVIND

















144/510

IV

1765808



260x348 mm

a	-	-								
b	144/501 II	1765985							E4 024107	200x432 mm
c	144/502 IV	1767265							E4 024108	160x184 mm
d	-	-								
e	-	-								
f	144/512	1346380								

applicabile a | suitable to | verwendbar für:

SCANIA 94 CP



144/507



II (E4) 024107
200x432 mm



IV (E4) 024108
184x160 mm



applicabilità:
applicable to:
Verwendbar für

SCANIA SERIE 4 1996→2004
SCANIA SERIE R/P/T 2004→

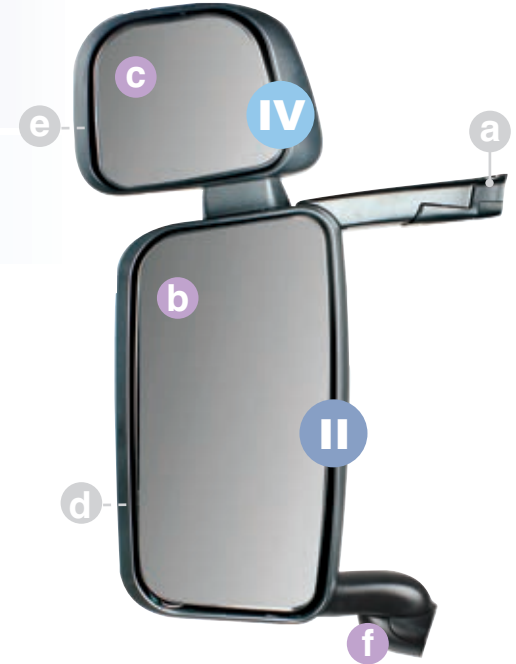
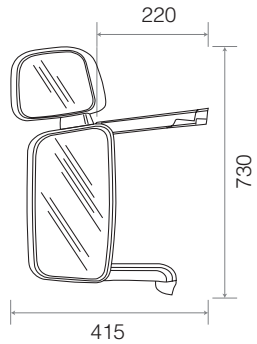

COVIND







144/511

1765809



260x348 mm

IV

a	-	-			E4 024107	200x432 mm
b	144/501	1765985	II			
c	144/502	1767265			E4 024108	184x160 mm
d	-	-				
e	-	-				
f	144/512	1346380				

applicabile a | suitable to | verwendbar für:

SCANIA 94 CP



144/508



II

E4 024107

200x432 mm



IV

E4 024108

184x160 mm



applicabilità:
applicable to:
Verwendbar für

SCANIA SERIE 4 1996→2004
SCANIA SERIE R/P/T 2004→

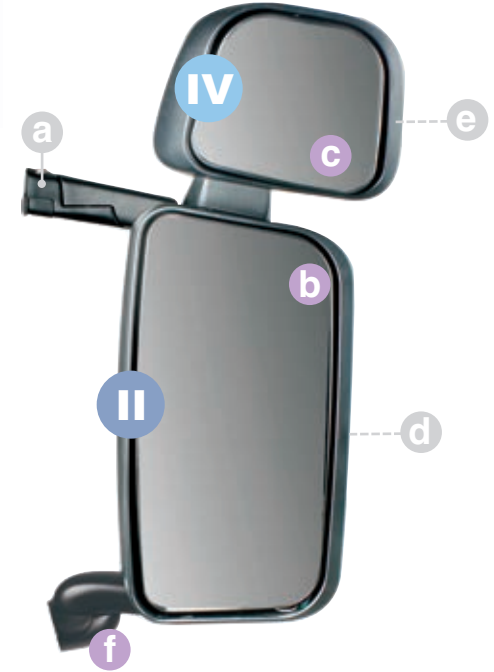
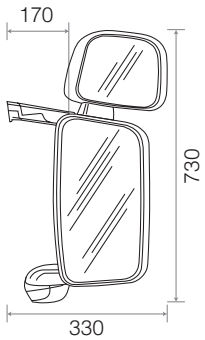

COVIND

144/510

1765808



260x348 mm

IV

a	-	-							
b	144/501 II	1765985							E4 024107 200x432 mm
c	144/502 IV	1767265							E4 024108 184x160 mm
d	-	-							
e	-	-							
f	144/512	1346380							

applicabile a | suitable to | verwendbar für:

SCANIA 94 CP



144/509



II (E4) 024107
200x432 mm



IV (E4) 024108
184x160 mm

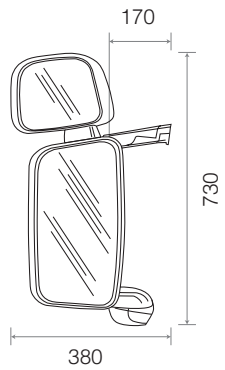

applicabilità:
applicable to:
Verwendbar für

SCANIA SERIE 4 1996→2004
SCANIA SERIE R/P/T 2004→

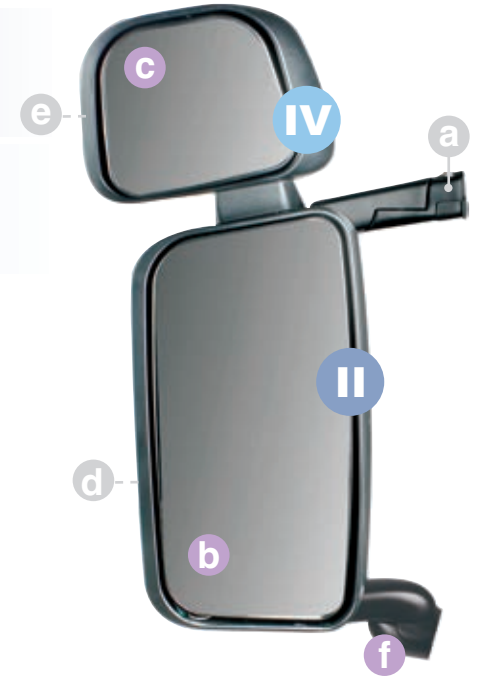

COVIND

144/511
IV

1765809



260x348 mm

a

-

-

b

144/501

1765985



E4 024107

200x432 mm

II

c

144/502

1767265



E4 024108

184x160 mm

IV

d

-

-

e

-

-

f

144/512

1346380



applicabile a | suitable to | verwendbar für:

SCANIA 94 CP

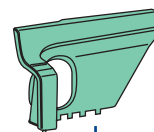
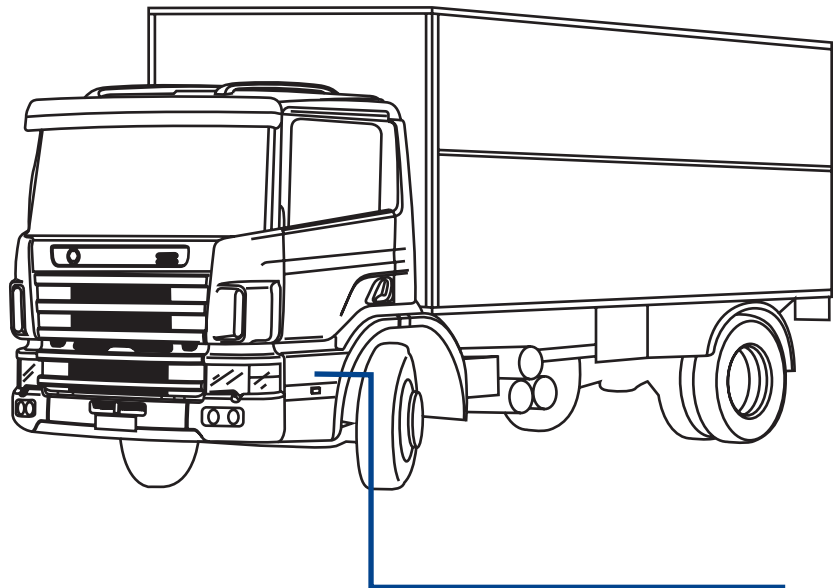

144/236 d-rh-rechts
144/237 s-lh-links

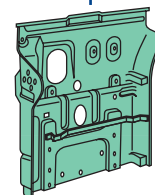

144/230 d-rh-rechts
144/231 s-lh-links



144/230
O.E.M. 1515194



144/231
O.E.M. 1515195



144/236
O.E.M. 1390074



144/237
O.E.M. 1390075

SCANIA 94 CP

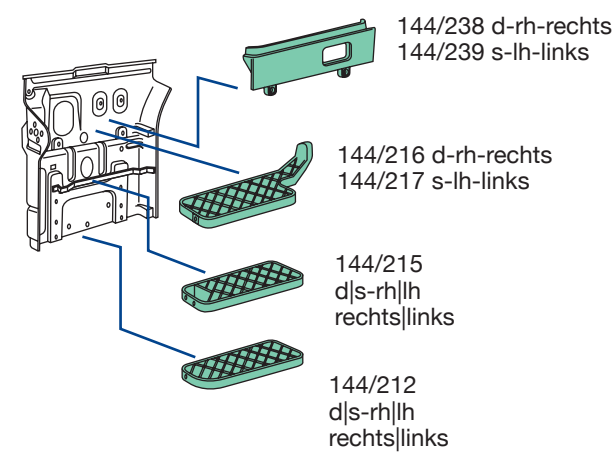
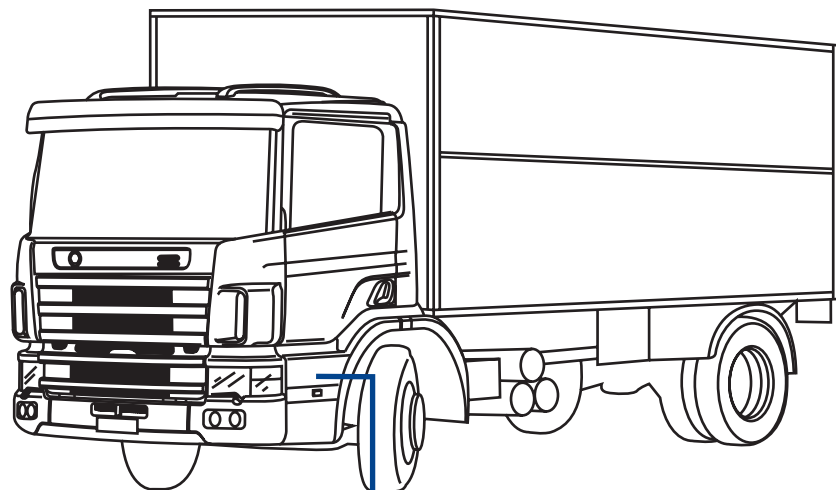

144/238
O.E.M. 1354594
144/239
O.E.M. 1354593



144/212
O.E.M. 1535049



144/215
O.E.M. 1535045



144/216
O.E.M. 1535036
144/217
O.E.M. 1535035

applicabile a | suitable to | verwendbar für:

SCANIA 94 CP

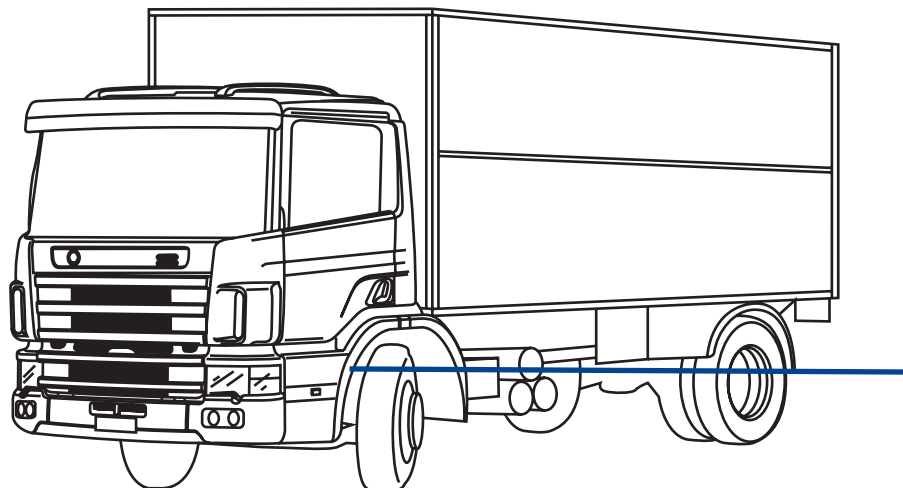

144/202 d-rh-rechts
144/203 s-lh-links

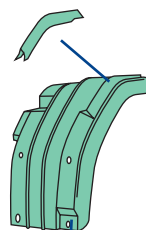

144/200
s-parte ant.
d-parte post.
lh-front section
rh-rear section
vorderer Teil li
Rueckseite re

144/210



144/200
O.E.M. 1485485



144/202
O.E.M. 1517650
144/203
O.E.M. 1517649



144/210
O.E.M. 1398873

SCANIA 94 CP

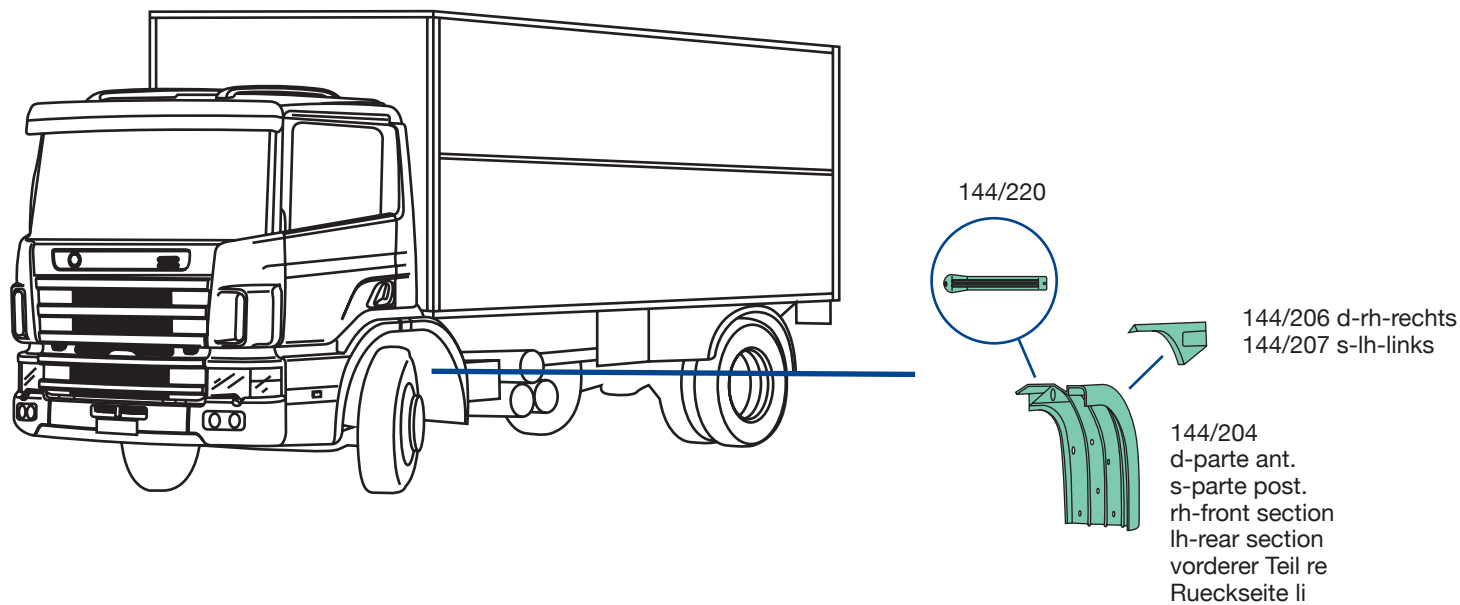

144/204
O.E.M. 1485486



144/206
O.E.M. 1364666
144/207
O.E.M. 1364665



144/220
O.E.M. 1479924

applicabile a | suitable to | verwendbar für:

SCANIA 94 CP

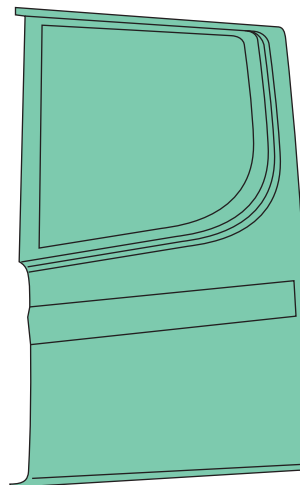
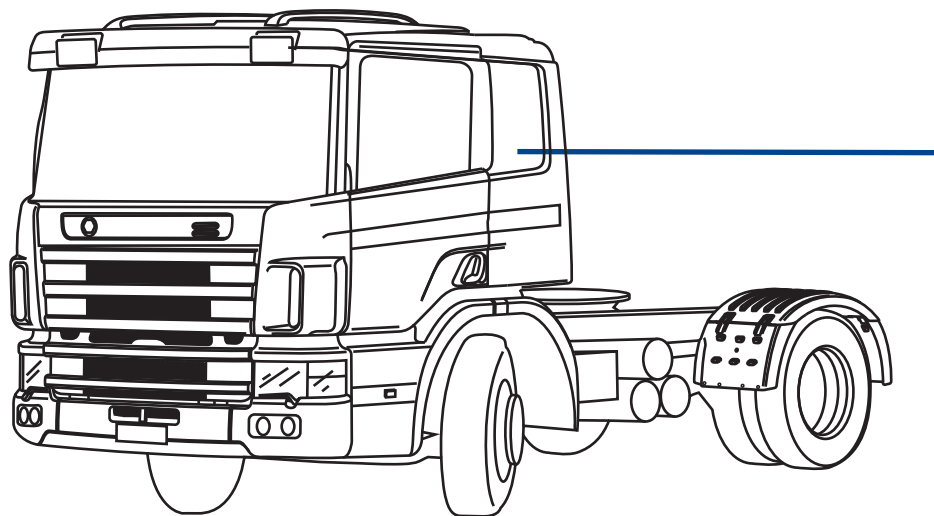

144/246 d-rh-rechts
144/247 s-lh-links

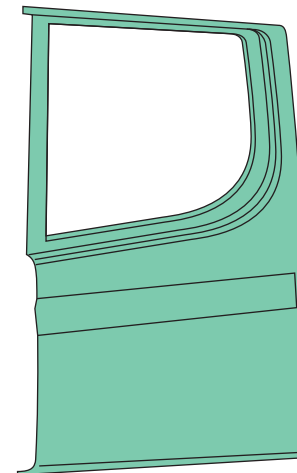

144/248 d-rh-rechts
144/249 s-lh-links



144/246
O.E.M. 1310214
144/247
O.E.M. 1310203



144/248
O.E.M. 1310204
144/249
O.E.M. 1310213

PDS/360

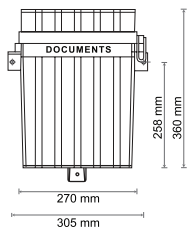

applicabile a | suitable to | verwendbar für:

SCANIA 94 CP

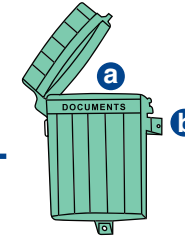
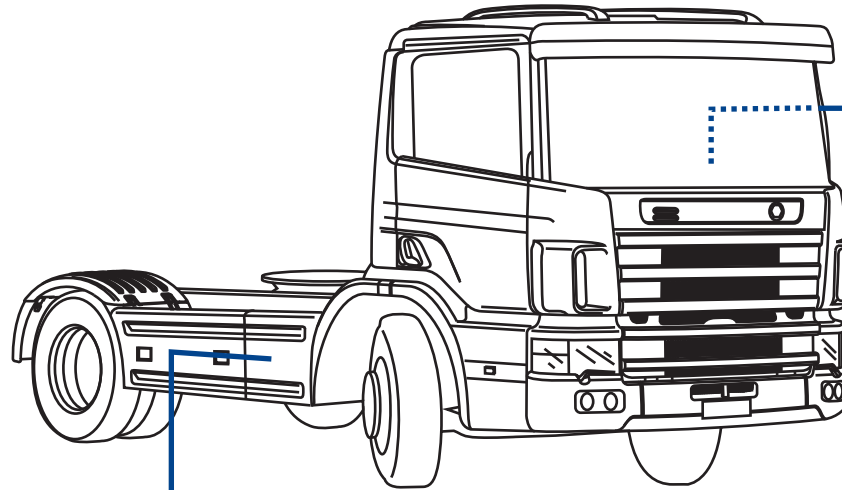

PDS/360

144/500
d-rh-rechts
senza staffe
without brackets
ohne Halter



144/500
O.E.M. 1496659



PDS/360
O.E.M. -

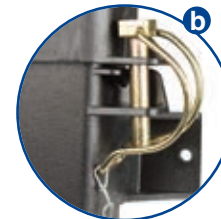

SCANIA 94 CP

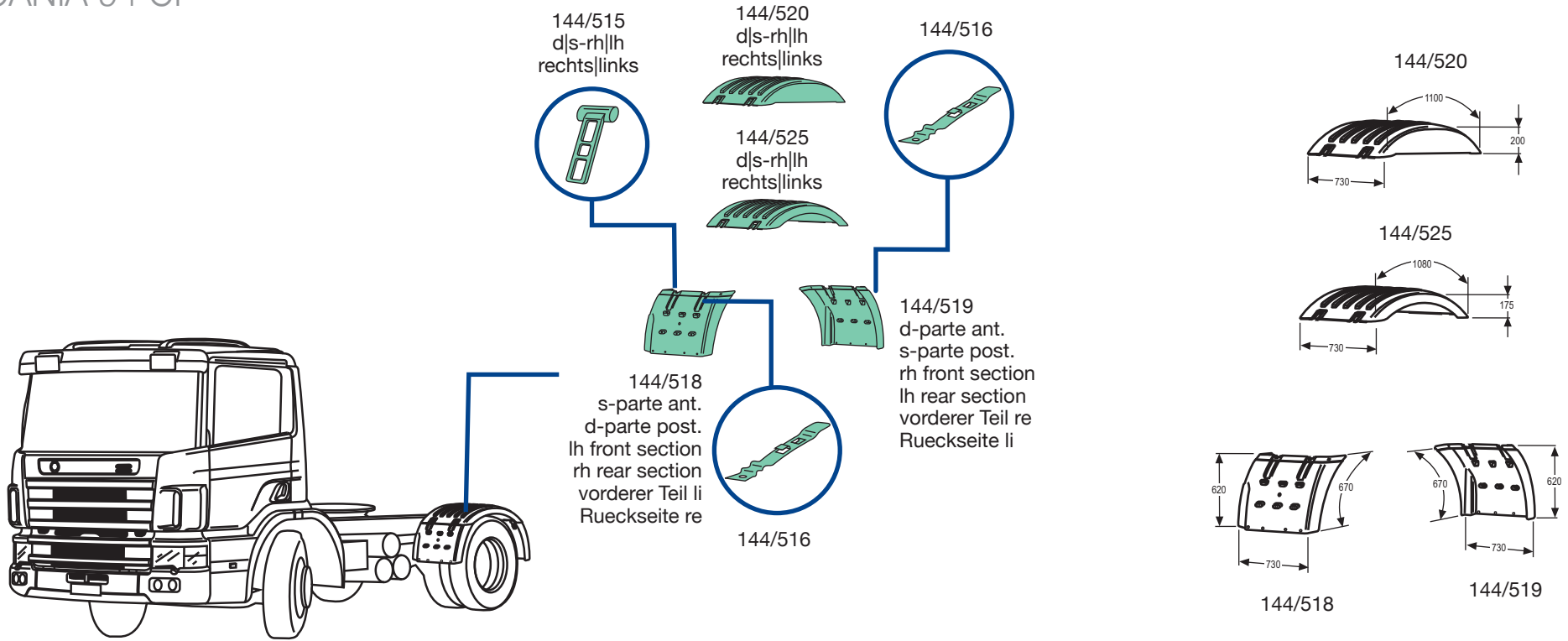

144/515
O.E.M. 1383858



144/516
O.E.M. 2056867

144/520
 O.E.M. 1357601
 d|s-rh||h-rechts|links
 grigio, circolare, senza cinghietti
 grey, circular, without stretchers
 grau, halbrund, ohne Spanngummi



144/519
 O.E.M. 1357599
 d|s-rh||h-rechts|links
 grigio, senza anti-spray
 grey, without anti-spray
 grau, ohne Spritzschutz



144/518
 O.E.M. 1357600
 d|s-rh||h-rechts|links
 grigio
 grey
 grau

144/525
 O.E.M. 1395276
 d|s-rh||h-rechts|links
 grigio, semipiatta, senza cinghietti
 grey, semi-flat, without stretchers
 grau, halbflach, ohne Spanngummi



144/518

SCANIA 94 CP

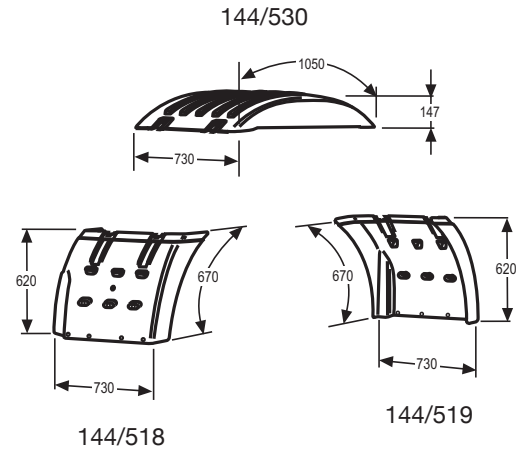
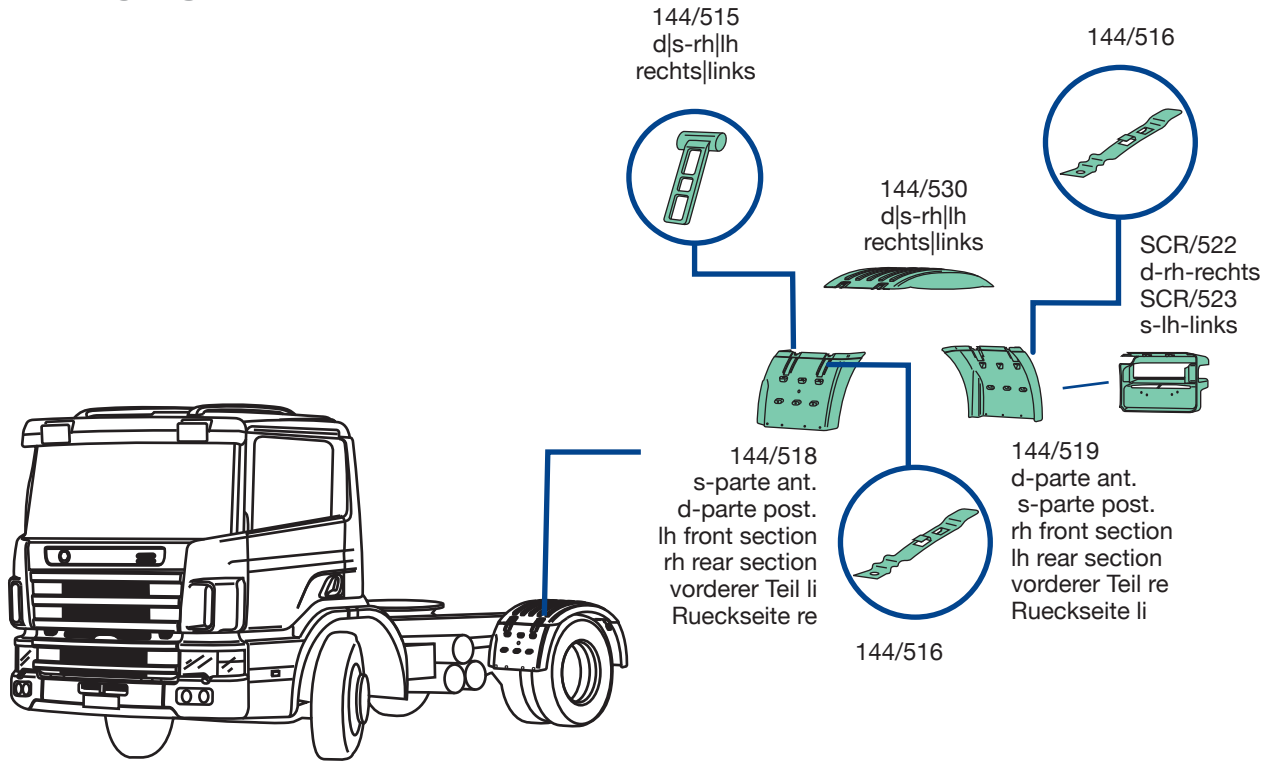

144/515
O.E.M. 1383858



144/516
O.E.M. 2056867



SCR/522
O.E.M. 2026621
SCR/523
O.E.M. 1362708

144/530
 O.E.M. 1357602
 d|s-rh||h-rechts|links
 grigio, piatta, senza cinghietti
 grey, flat, without stretchers
 grau, flach, ohne Spanngummi

144/519
 O.E.M. 1357599
 d|s-rh||h-rechts|links
 grigio, senza anti-spray
 grey, without anti-spray
 grau, ohne Spritzschutz

144/518
 O.E.M. 1357600
 d|s-rh||h-rechts|links
 grigio
 grey
 grau



applicabile a | suitable to | verwendbar für:

SCANIA 94 CP

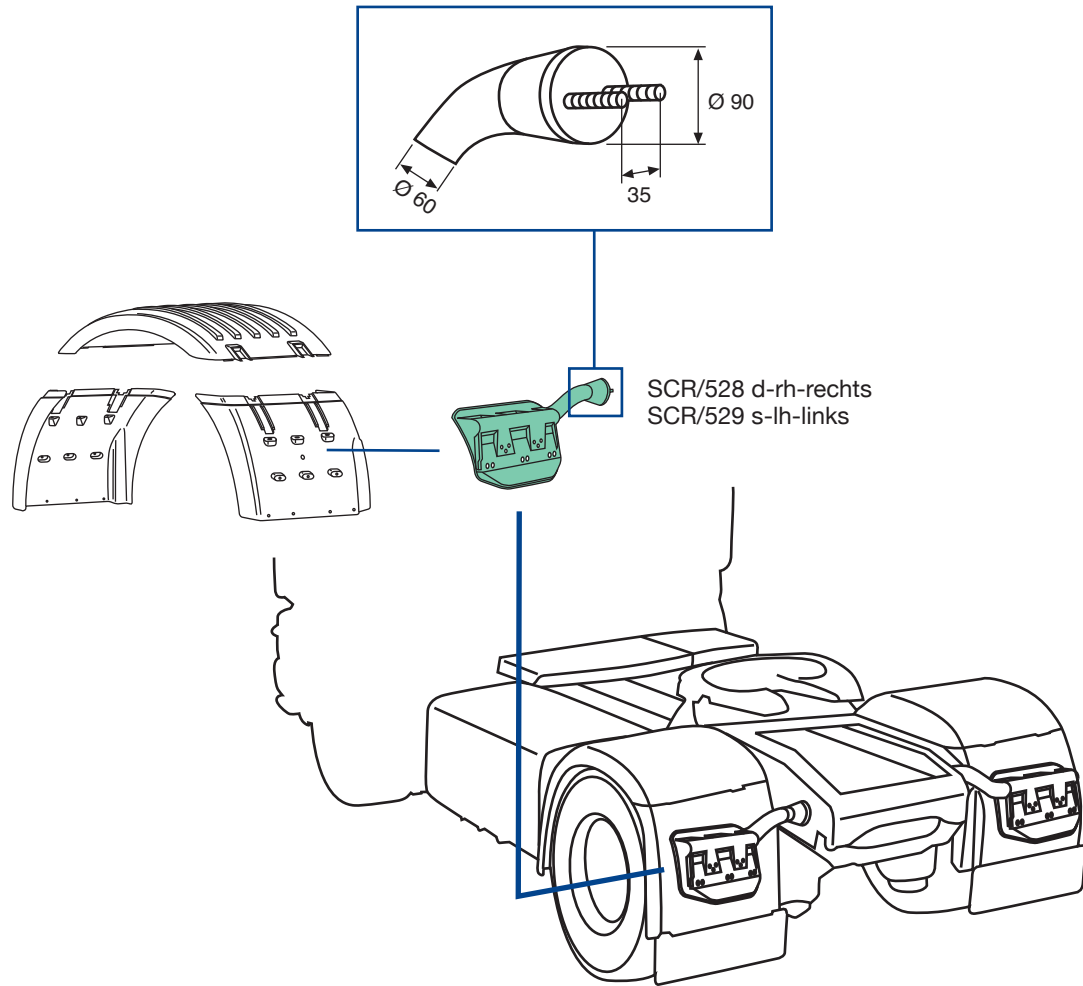



SCR/529
O.E.M. 2054603
posteriore sinistro
rear left
hinten links

SCR/528
O.E.M. 2054604
posteriore destro
rear right
hinten rechts



applicabile a | suitable to | verwendbar für:

SCANIA 94 CP

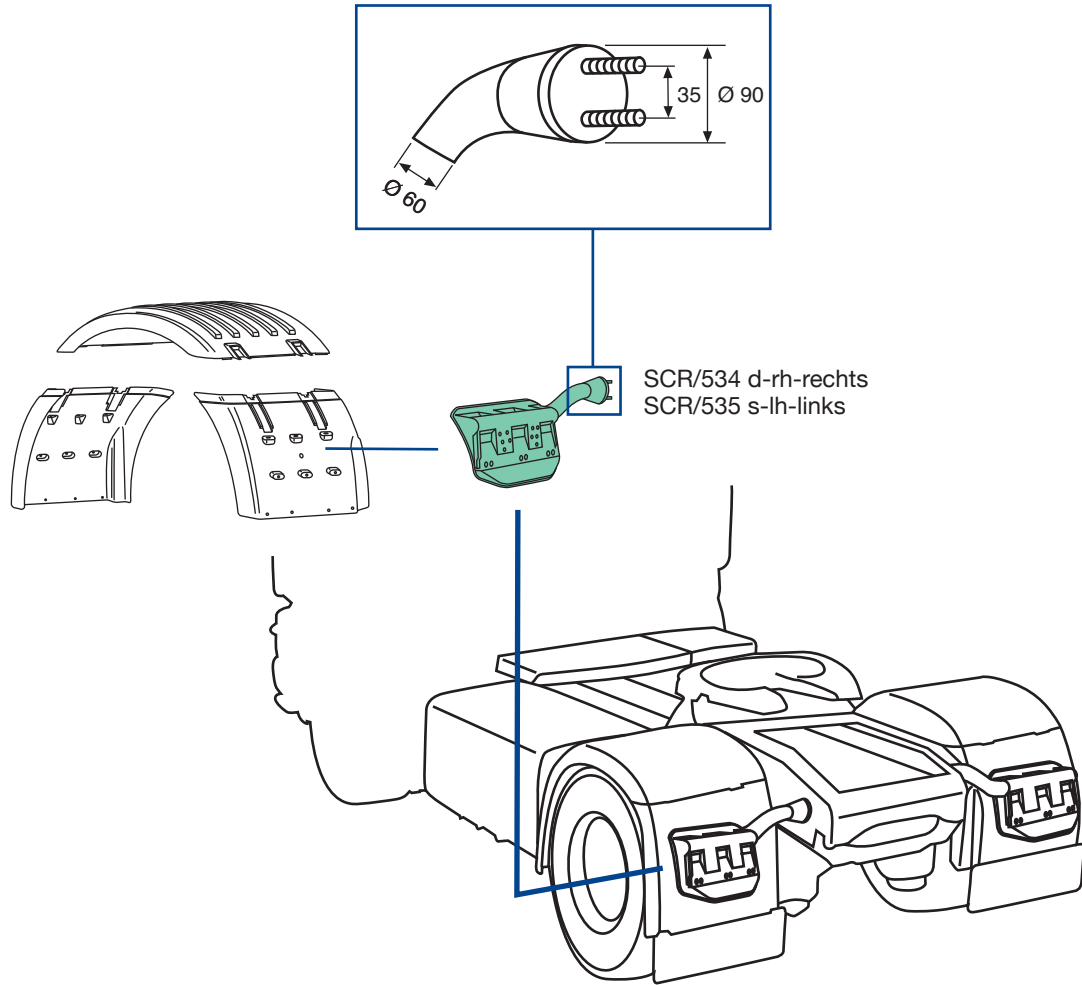



SCR/535
O.E.M. 2054601
posteriore sinistro
rear left
hinten links

SCR/534
O.E.M. 2054602
posteriore destro
rear right
hinten rechts



applicabile a | suitable to | verwendbar für:

SCANIA 94 CP

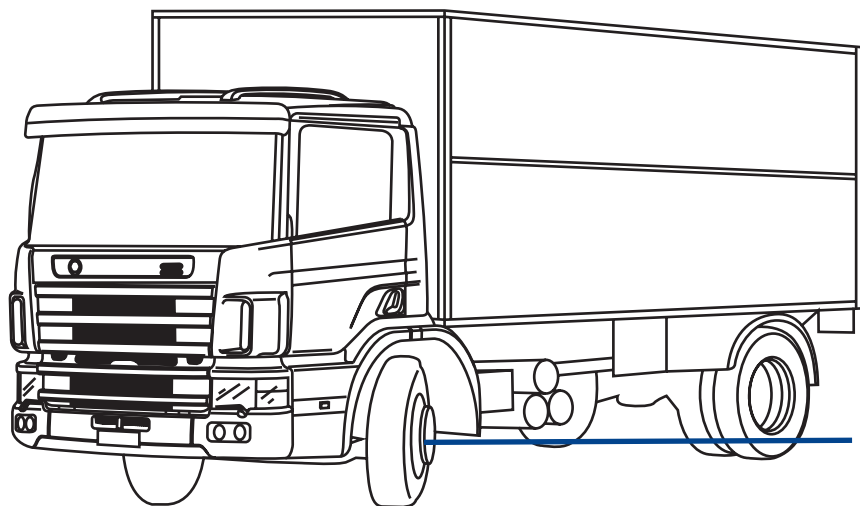

930/033

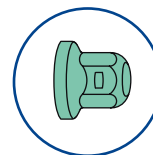

930/100
d-rh-rechts
930/101
s-lh-links



930/001
d-rh-rechts
930/002
s-lh-links

930/200
d|s-rh|lh
rechts|links



930/033
O.E.M. -



930/001
O.E.M. -
930/002
O.E.M. -



930/100
O.E.M. -
930/101
O.E.M. -

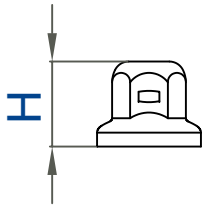

930/200
O.E.M. -

930/033 - Tappo copri Bullone - Bolt cover - Radmutterkappen

H	45 mm
Per bulloni \varnothing - bolt \varnothing	33 mm
Schlüsselweite \varnothing	
Colore	cromato-chrome-verchromt
Colours-Farbe	
Materiale-Material	acciaio inox-stainless steel Edelstahl
Kg	0,025

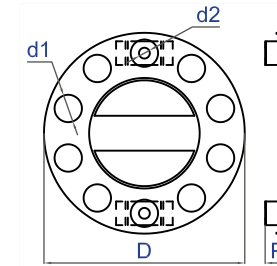
**930/001 d-rh-rechts - 930/002 s-lh-links**

D \varnothing 425 mm	P 50 mm
d1 nr. 10	d1 \varnothing 58 mm
d2 nr. 2	d2 \varnothing 23 mm
Ventilata	si-yes-Ja
Ventilated-Belüftet	
Colore	cromato e nero-chrome and black
Colours-Farbe	verchromt und schwarz
Materiale-Material	acciaio inox e plastica stainless steel and plastic Edelstahl und Kunststoff
Kg	1,230

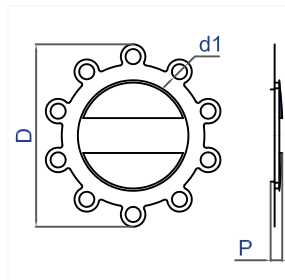
**930/100 d-rh-rechts - 930/101 s-lh-links**

D \varnothing 387 mm	P 30 mm
d1 nr. 10	d1 \varnothing 32 mm
Ventilata	si-yes-Ja
Ventilated-Belüftet	
Colore	cromato e nero-chrome and black
Colours-Farbe	verchromt und schwarz
Materiale-Material	acciaio inox e plastica stainless steel and plastic Edelstahl und Kunststoff
Kg	0,655

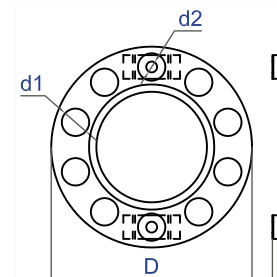
**930/200 d|s-rh|lh-rechts|links**

D \varnothing 425 mm	P 40 mm
d1 nr. 10	d1 \varnothing 58 mm
d2 nr. 2	d2 \varnothing 23 mm
Ventilata	no-nein
Ventilated-Belüftet	
Colore	cromato-chrome-verchromt
Colours-Farbe	
Materiale-Material	acciaio inox-stainless steel Edelstahl
Kg	1,155



IT Stampo per la produzione del deviatore aria per il veicolo Scania (Cod. Covind SCR/161)
EN Mould for the production of the air buffle for the Scania vehicles (Cod. Covind SCR/161)
DE Stahlform für die Produktion des Scania Luftabweiser (Covind Nr. SCR/161)



applicabile a | suitable to | verwendbar für 277

144
SCANIA 144 CR

L CLASS CR 114-124-144

applicabile a | suitable to | verwendbar für:

SCANIA 144 CR

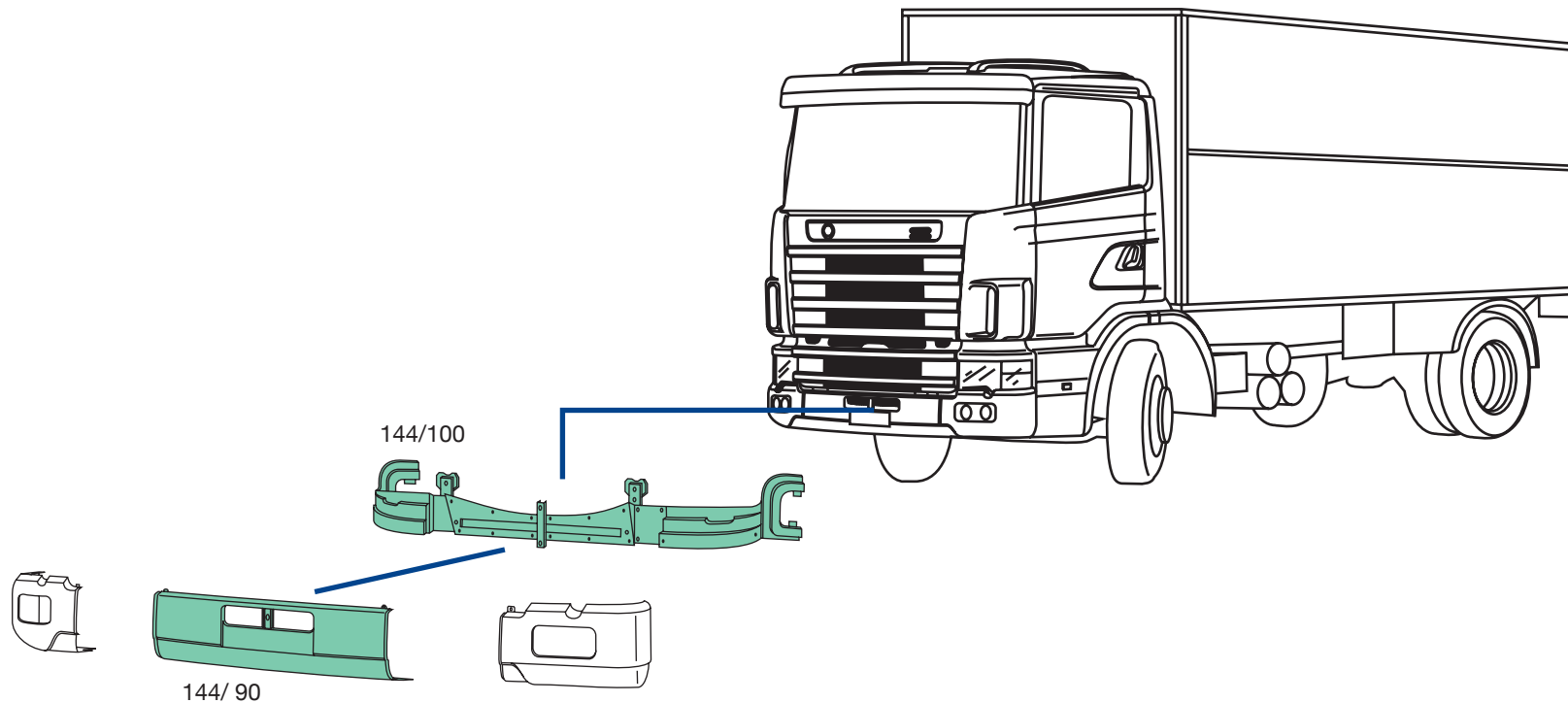

144/90
O.E.M. 1400213



144/100
O.E.M. 1499230

SCANIA 144 CR

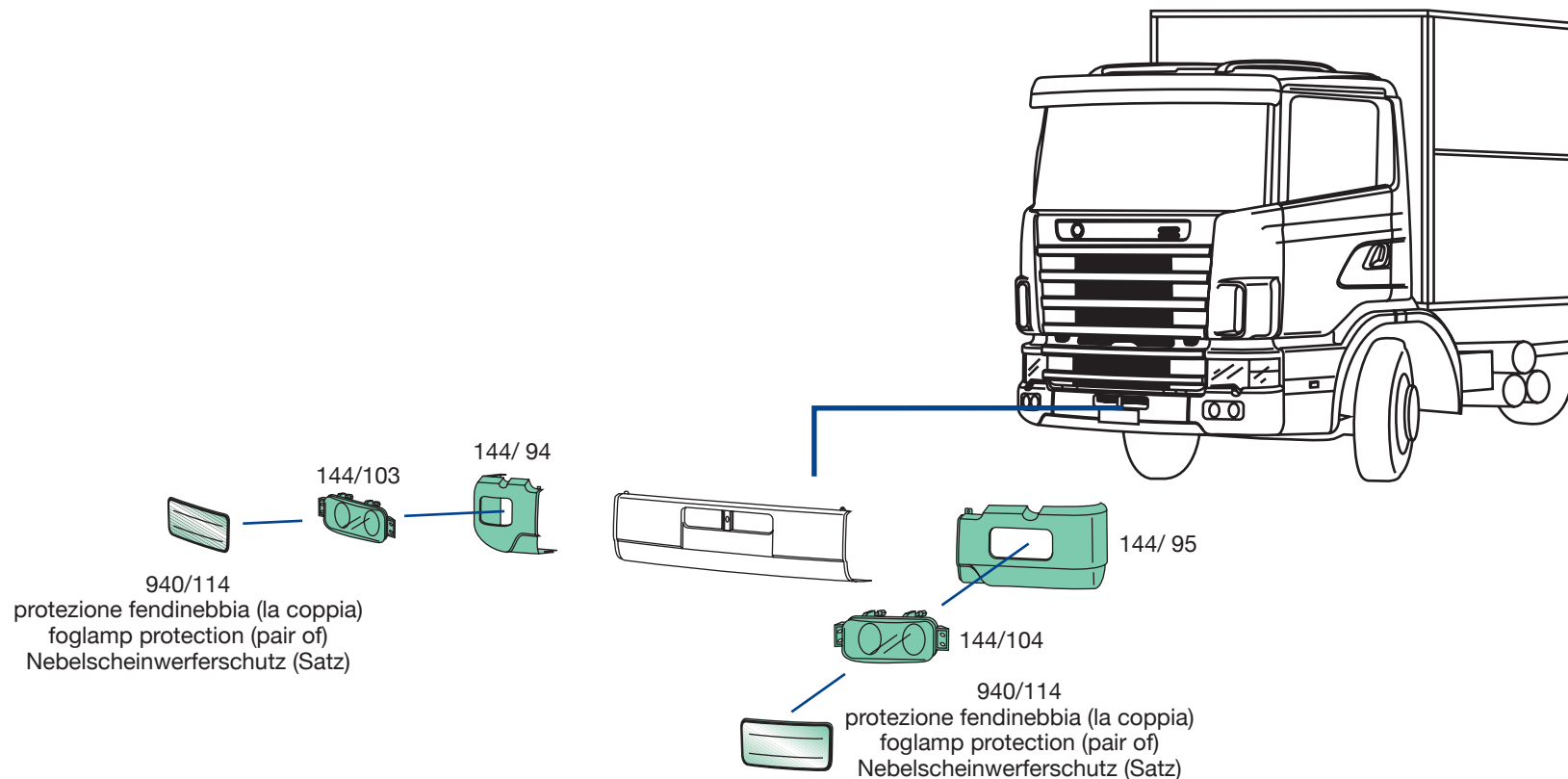

144/ 94
O.E.M. 1324598
144/ 95
O.E.M. 1324597



144/103
O.E.M. 1529071
144/104
O.E.M. 1529070



940/114
O.E.M. -

applicabile a | suitable to | verwendbar für:

SCANIA 144 CR

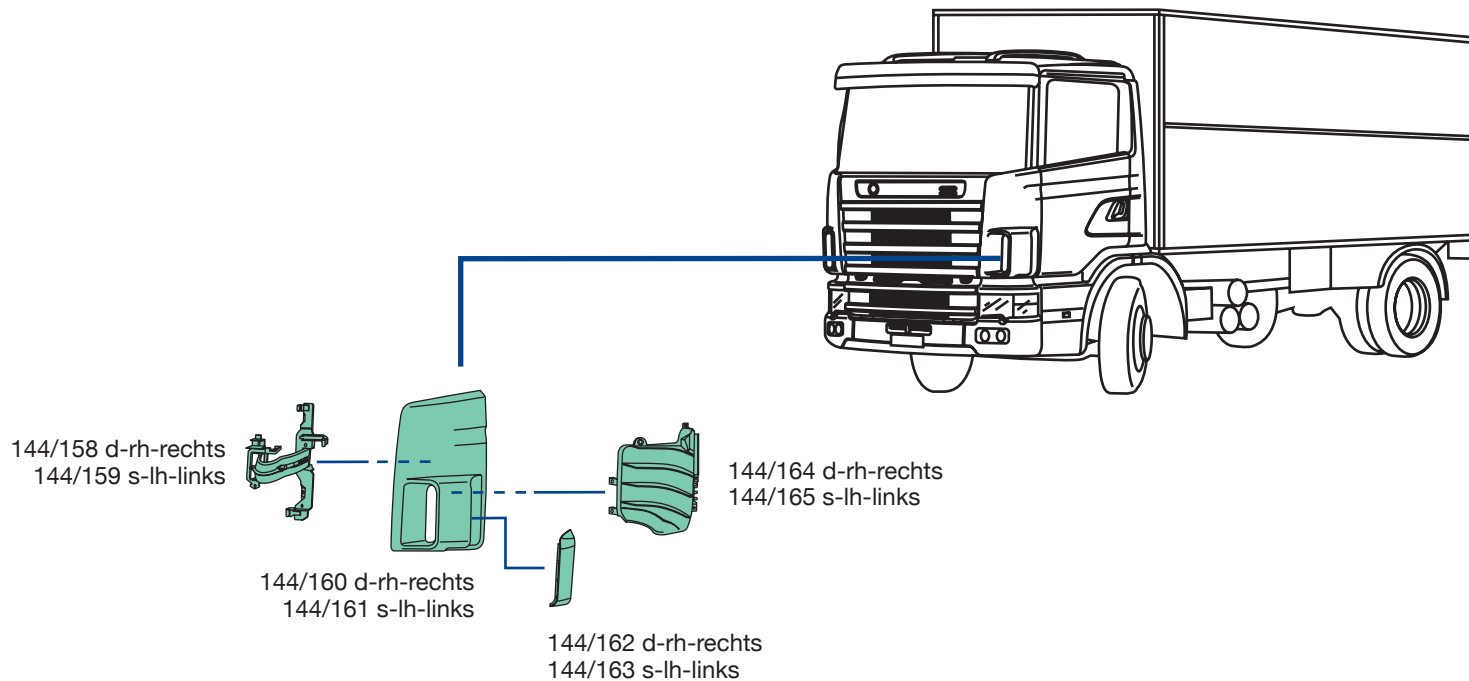

144/160
O.E.M. 1370330
144/161
O.E.M. 1370329



144/162
O.E.M. 1382728
144/163
O.E.M. 1382727



144/164
O.E.M. 1381566
144/165
O.E.M. 1381565



144/158
O.E.M. 1726851
144/159
O.E.M. 1440108

SCANIA 144 CR

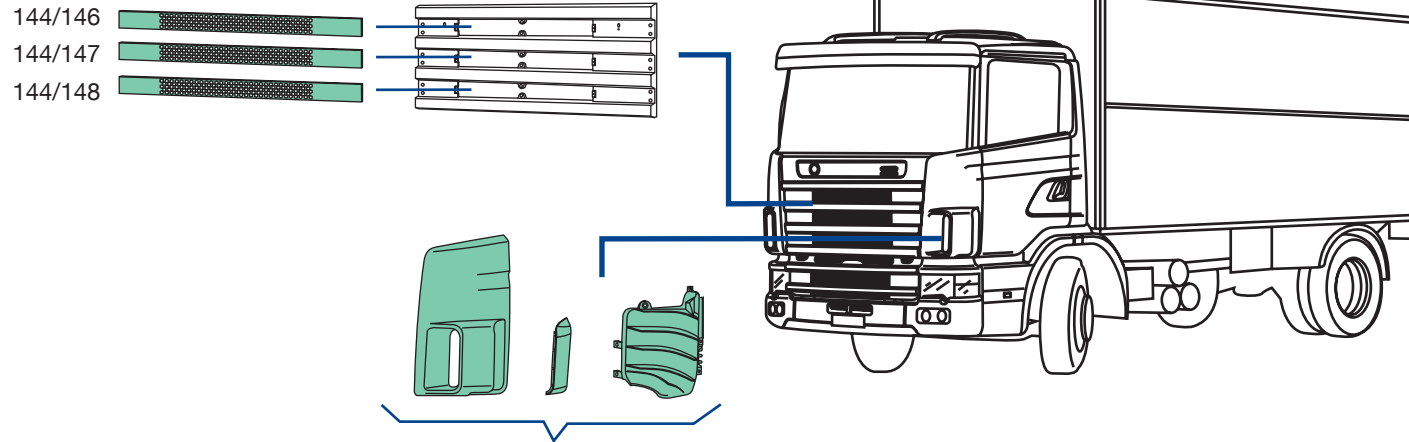

144/600
d-rh-rechts
KIT - Satz
composto da:
composed by:
bestehend aus:
144/160+144/162+144/164

144/601
s-lh-links
KIT - Satz
composto da:
composed by:
bestehend aus:
144/161+144/163+144/165



144/146
O.E.M. 1401929



144/147
O.E.M. 1371757



144/148
O.E.M. 1371758



144/600
O.E.M. -
144/601
O.E.M. -

applicabile a | suitable to | verwendbar für:

SCANIA 144 CR

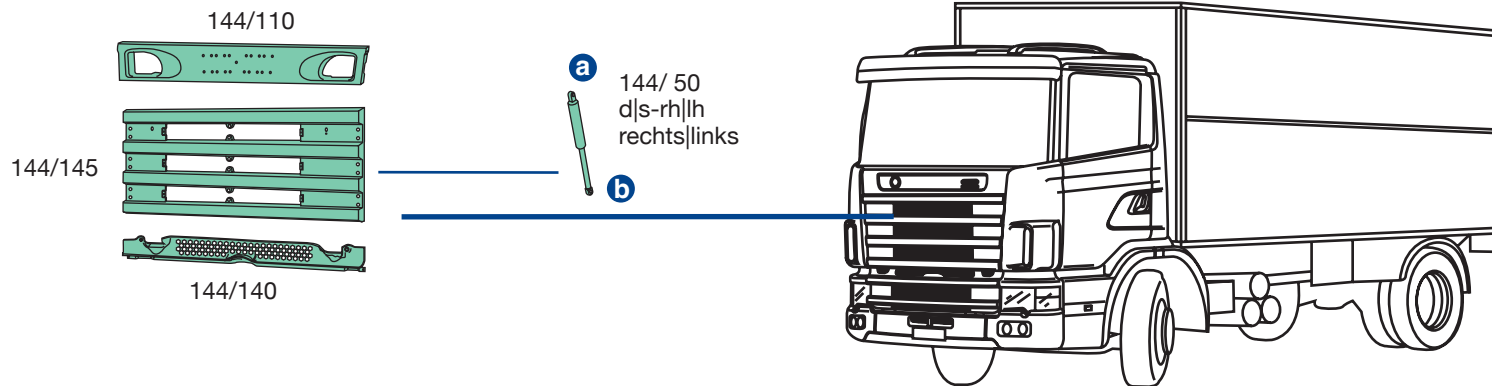

O.E.M. 1306492

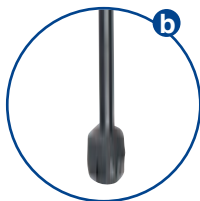

O.E.M. 1383609



O.E.M. 1870689



O.E.M. 1397570

SCANIA 144 CR

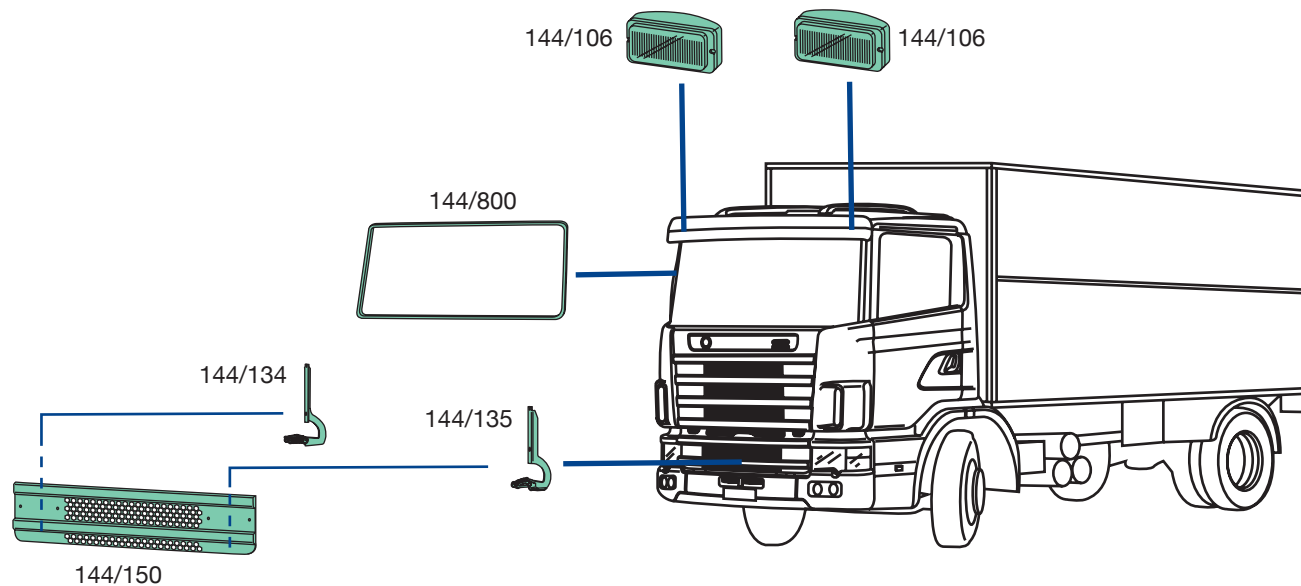

144/106
O.E.M. 1749953



144/134
O.E.M. 1381480
144/135
O.E.M. 1381479



144/150
O.E.M. 1366384



144/800
O.E.M. 1366851

applicabile a | suitable to | verwendbar für:

SCANIA 144 CR

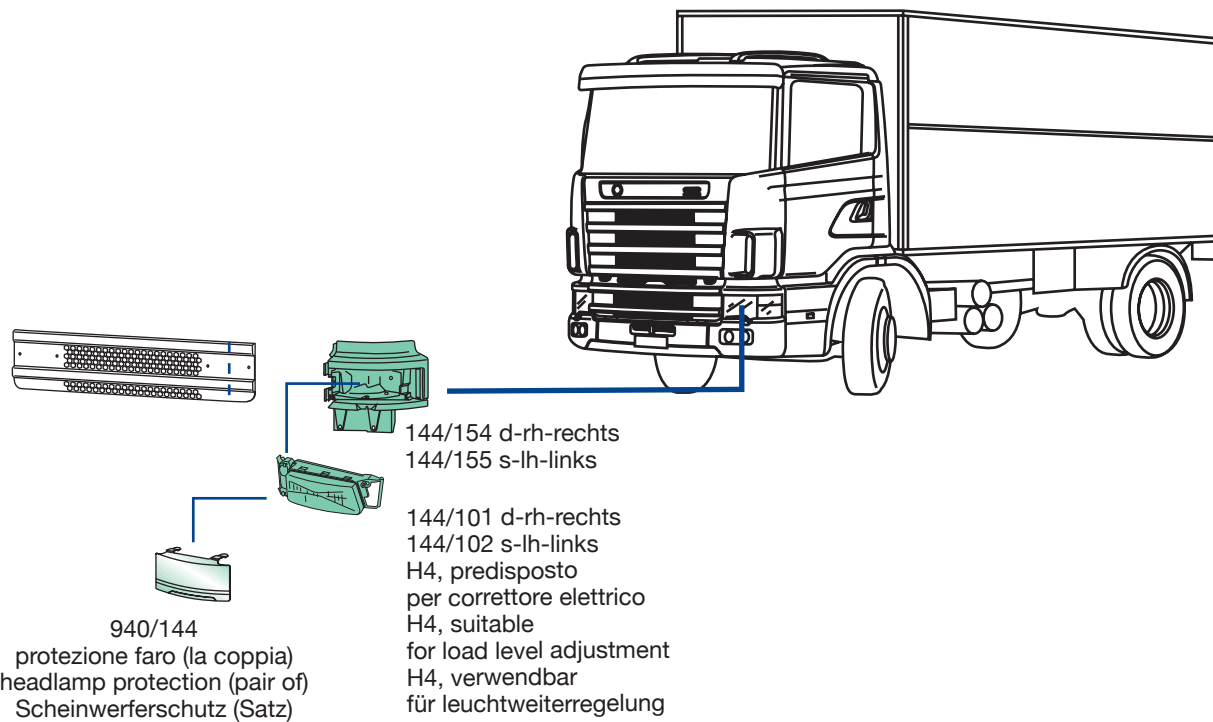

144/101
O.E.M. 1732510
144/102
O.E.M. 1732509



144/154
O.E.M. 1543635
144/155
O.E.M. 1543634



940/144
O.E.M. -

SCR/ 2 d-rh-rechts
SCR/ 3 s-lh-links
lastrata, con cerniere
paneled with hinges
rohbautür, mit Scharnier

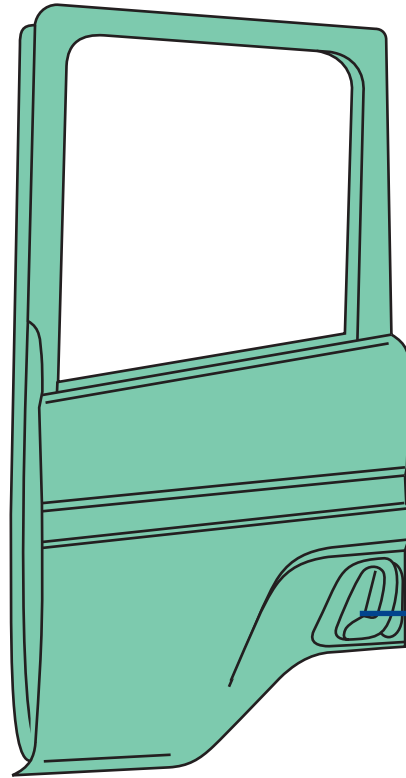

144/194 d-rh-rechts
144/195 s-lh-links

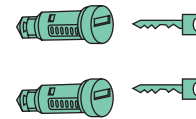
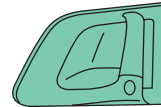

144/196
d|s-rh|lh
rechts|links

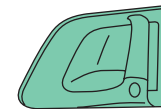

SCR/194 d-rh-rechts
SCR/195 s-lh-links



SCR/ 2
O.E.M. 1476535
SCR/ 3
O.E.M. 1476534



144/194
O.E.M. 2145648
144/195
O.E.M. 2145647



144/196
O.E.M. 1485072



SCR/194
O.E.M. -
SCR/195
O.E.M. -

applicabile a | suitable to | verwendbar für:

SCANIA 144 CR

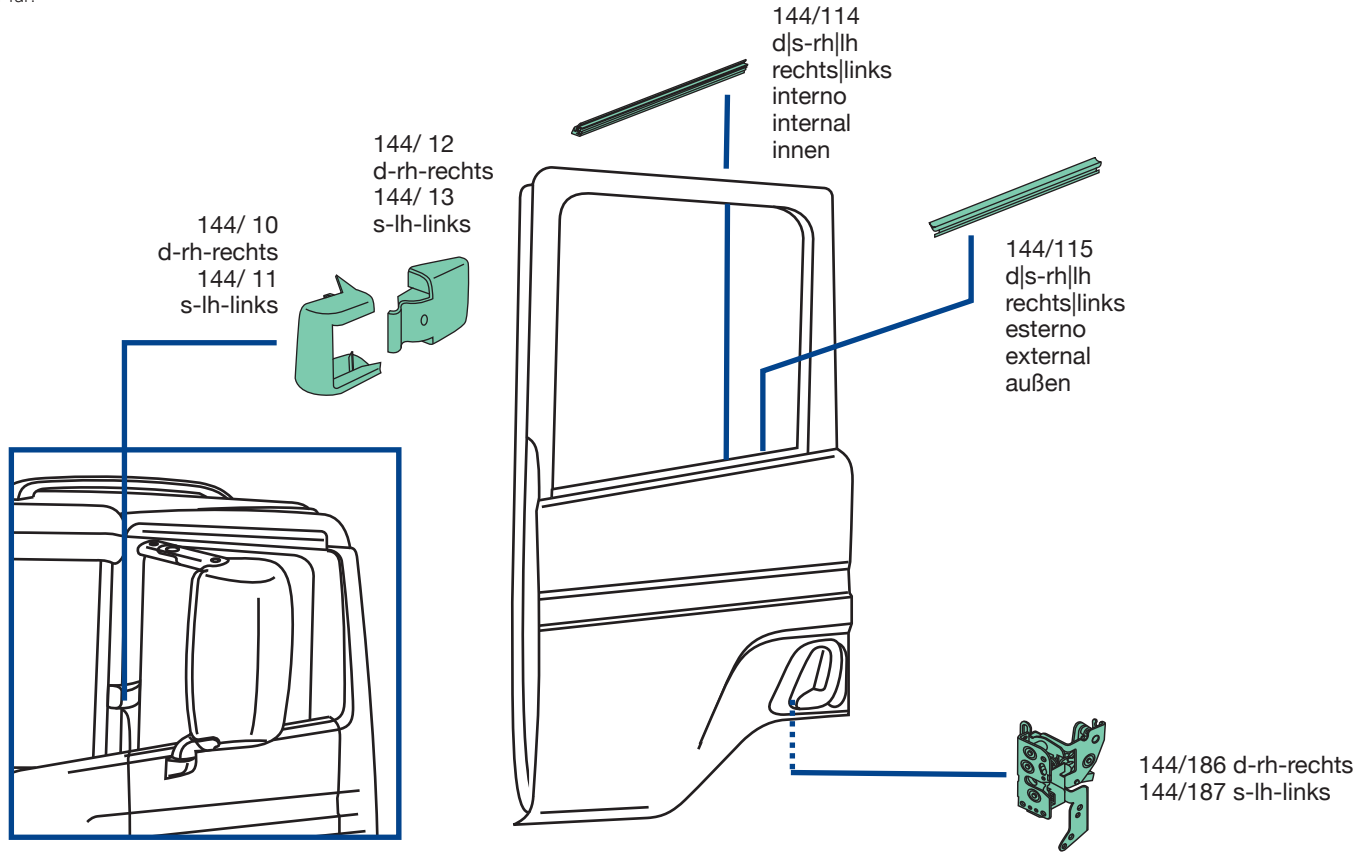

144/10
O.E.M. 1472832
144/11
O.E.M. 1472833



144/12
O.E.M. 1346940
144/13
O.E.M. 1346939



144/114
O.E.M. 1865520

144/115
O.E.M. 1865517



144/186
O.E.M. 1867655
144/187
O.E.M. 1867654

SCANIA 144 CR

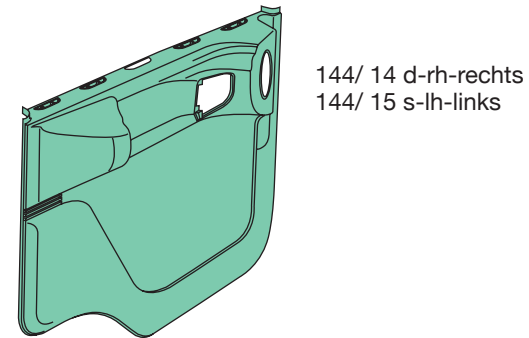
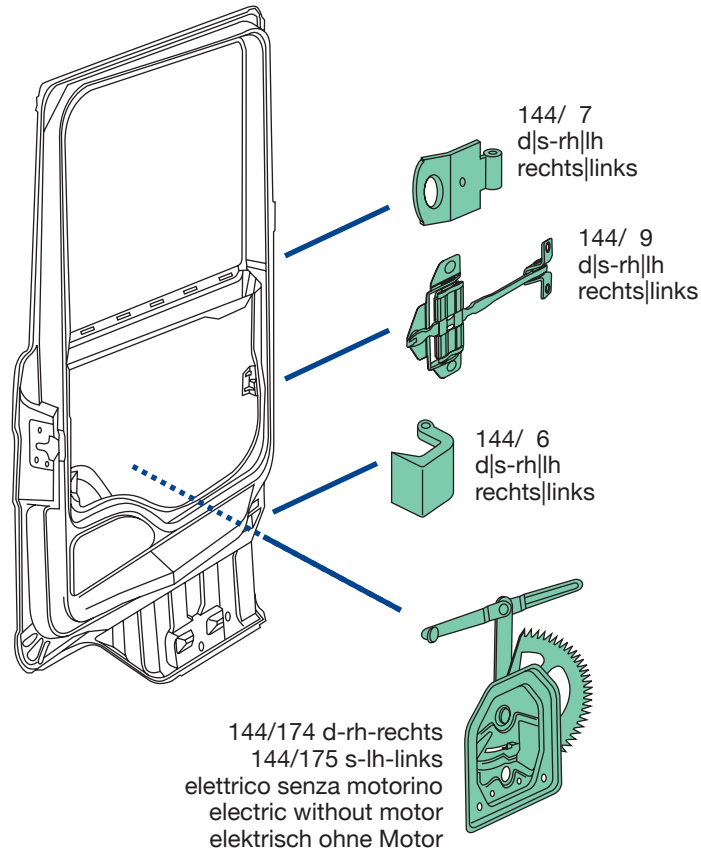

144/ 6
O.E.M. 1426925



144/ 7
O.E.M. 1422292



144/ 9
O.E.M. 1930649



144/ 14
O.E.M. 1346164
144/ 15
O.E.M. 1346163



144/174
O.E.M. 2303352
144/175
O.E.M. 2303349

applicabile a | suitable to | verwendbar für:

SCANIA 144 CR



144/503



E4 024107

200x432 mm



applicabilità:
applicable to:
Verwendbar für

SCANIA SERIE 4 1996→2004
SCANIA SERIE R/P/T 2004→

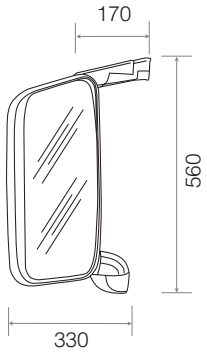

a

-

-

b

144/501

1765985



E4 024107

200x432 mm



d

-

-

f

144/512

1346380



applicabile a | suitable to | verwendbar für:

SCANIA 144 CR



144/505

2425815
(1723518)



|| E4 024107
200x432 mm



applicabilità:
applicable to:
Verwendbar für

SCANIA SERIE 4 1996→2004
SCANIA SERIE R/P/T 2004→

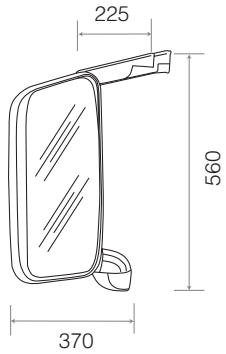

COVIND

||

IV

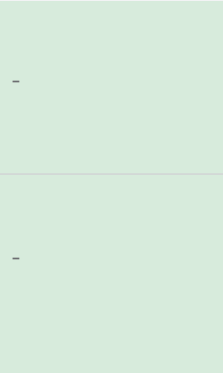

a

-

-

b

144/501

1765985



E4 024107

200x432 mm



d

-

-

f

144/512

1346380



applicabile a | suitable to | verwendbar für:

SCANIA 144 CR



144/506

2425816
(1723519)



E4 024107

200x432 mm



E4 024108

160x184 mm

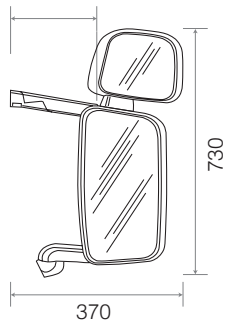

applicabilità:
applicable to:
Verwendbar für

SCANIA SERIE 4 1996→2004
SCANIA SERIE R/P/T 2004→

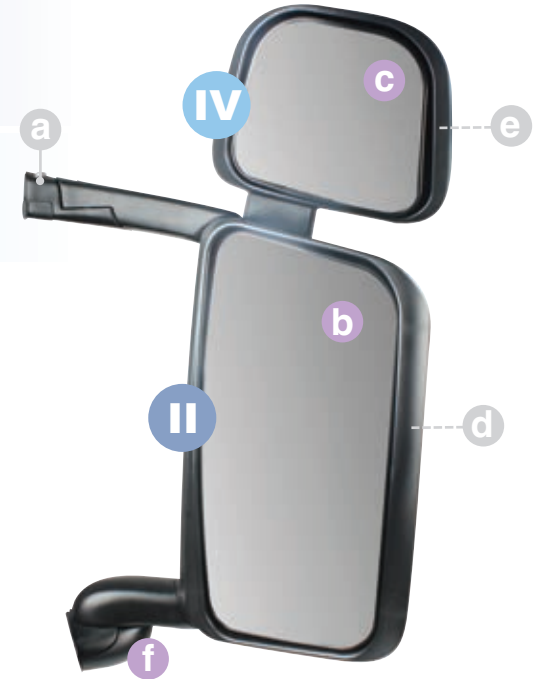

















COVIND

144/510 IV

1765808



260x348 mm

a	-	-							
b	144/501 II	1765985							E4 024107 200x432 mm
c	144/502 IV	1767265							E4 024108 160x184 mm
d	-	-							
e	-	-							
f	144/512	1346380							

applicabile a | suitable to | verwendbar für:

SCANIA 144 CR



144/507

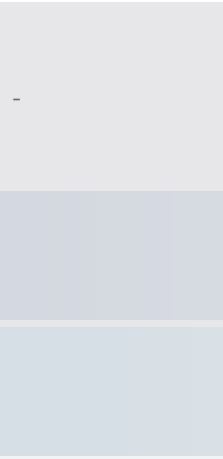

II (E4) 024107
200x432 mm



IV (E4) 024108
184x160 mm



applicabilità:
applicable to:
Verwendbar für

SCANIA SERIE 4 1996→2004
SCANIA SERIE R/P/T 2004→

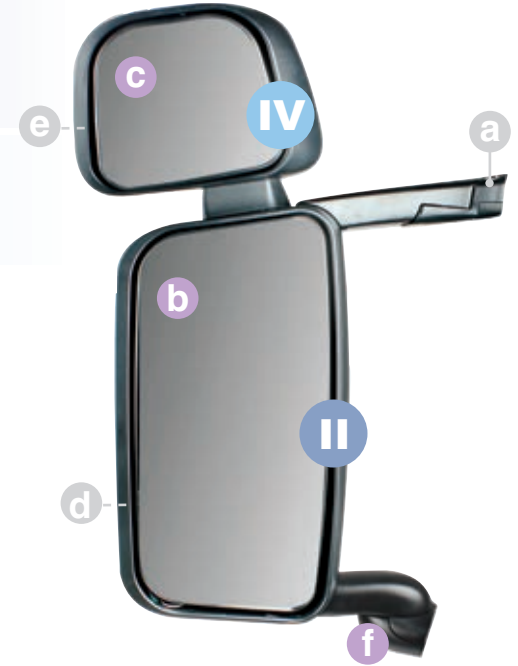
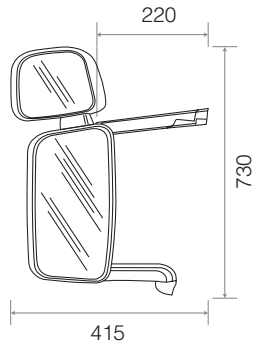

COVIND

144/511

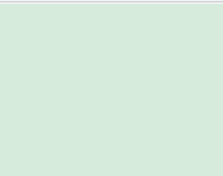







1765809



260x348 mm

IV

a	-	-			E4 024107	200x432 mm	
b	144/501	1765985	II				
c	144/502	1767265	IV			E4 024108	184x160 mm
d	-	-					
e	-	-					
f	144/512	1346380					

applicabile a | suitable to | verwendbar für:

SCANIA 144 CR



144/508



II (E4) 024107
200x432 mm



IV (E4) 024108
184x160 mm

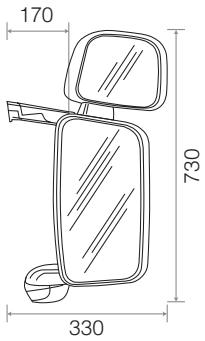

applicabilità:
applicable to:
Verwendbar für

SCANIA SERIE 4 1996→2004
SCANIA SERIE R/P/T 2004→

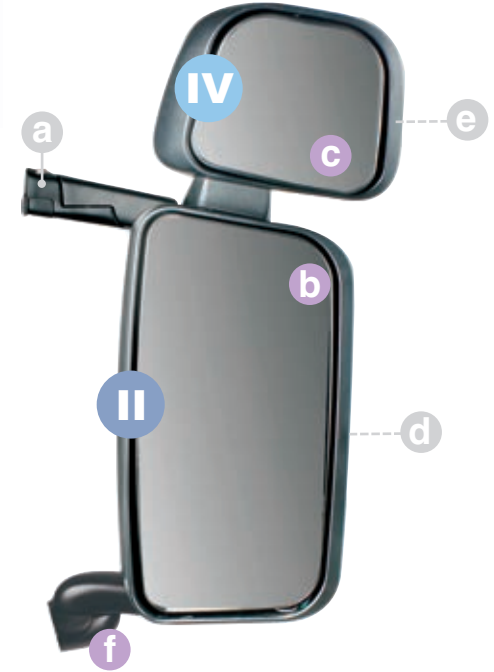

COVIND

















144/510

1765808



260x348 mm

IV

a	-	-								
b	144/501	1765985							E4 024107	200x432 mm
II										
c	144/502	1767265							E4 024108	184x160 mm
IV										
d	-	-								
e	-	-								
f	144/512	1346380								

applicabile a | suitable to | verwendbar für:

SCANIA 144 CR



144/509



II (E4)024107
200x432 mm



IV (E4)024108
184x160 mm

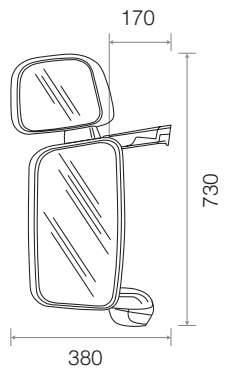

applicabilità:
applicable to:
Verwendbar für

SCANIA SERIE 4 1996→2004
SCANIA SERIE R/P/T 2004→

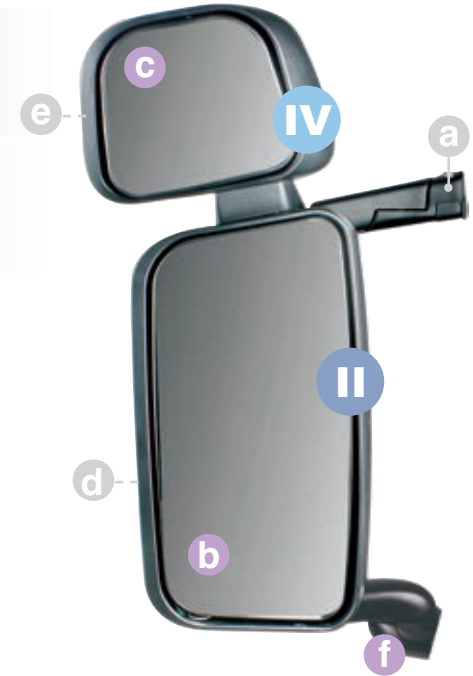

COVIND

144/511

1765809



260x348 mm

IV

a	-	-								
b	144/501 II	1765985							E4 024107	200x432 mm
c	144/502 IV	1767265							E4 024108	184x160 mm
d	-	-								
e	-	-								
f	144/512	1346380								

applicabile a | suitable to | verwendbar für:

SCANIA 144 CR

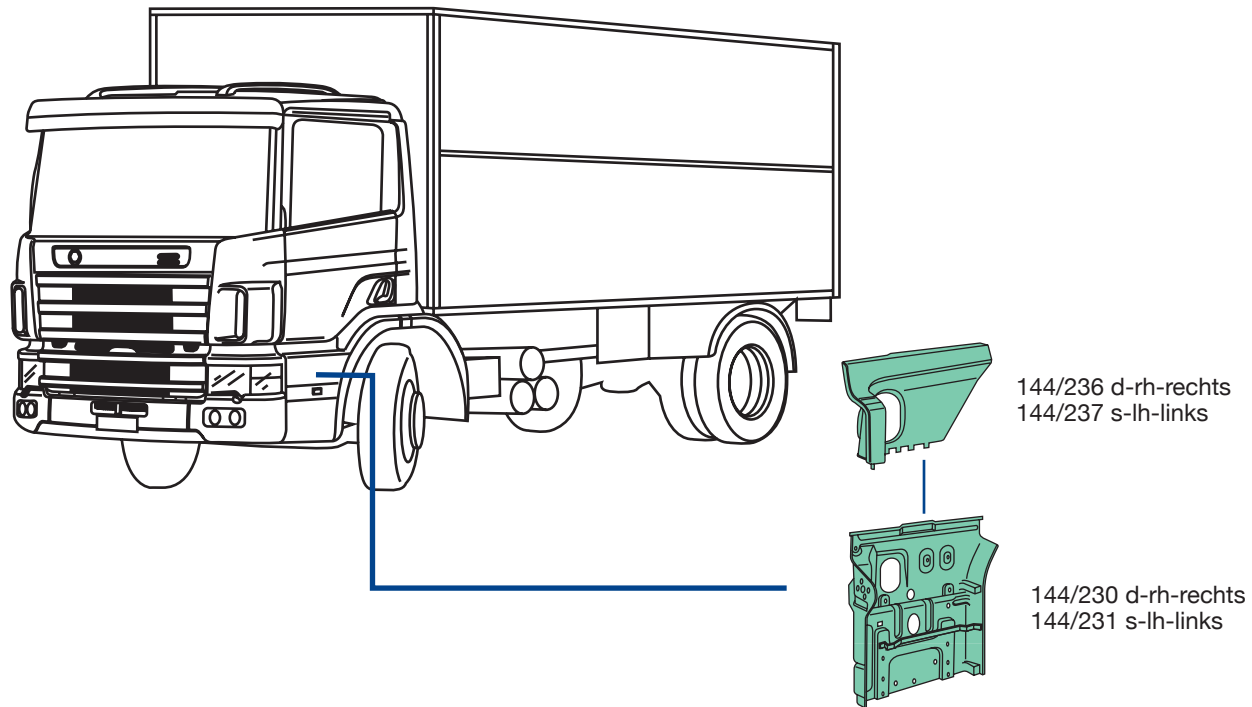

SCANIA 144 CR

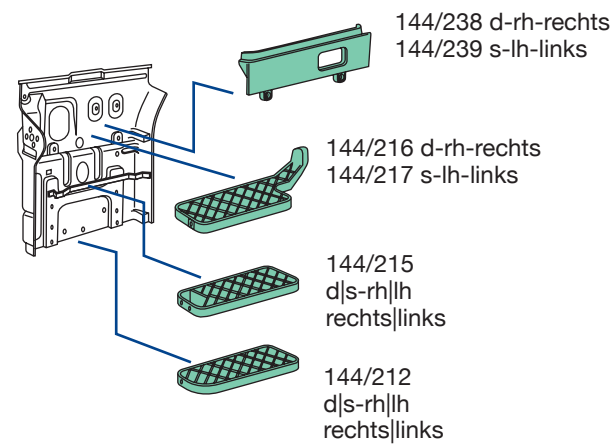
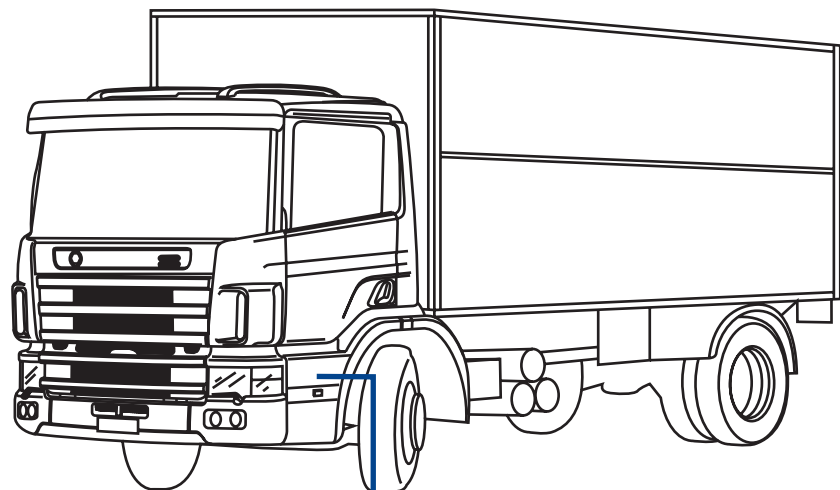

144/238
O.E.M. 1354594
144/239
O.E.M. 1354593



144/212
O.E.M. 1535049



144/215
O.E.M. 1535045



144/216
O.E.M. 1535036
144/217
O.E.M. 1535035

applicabile a | suitable to | verwendbar für:

SCANIA 144 CR

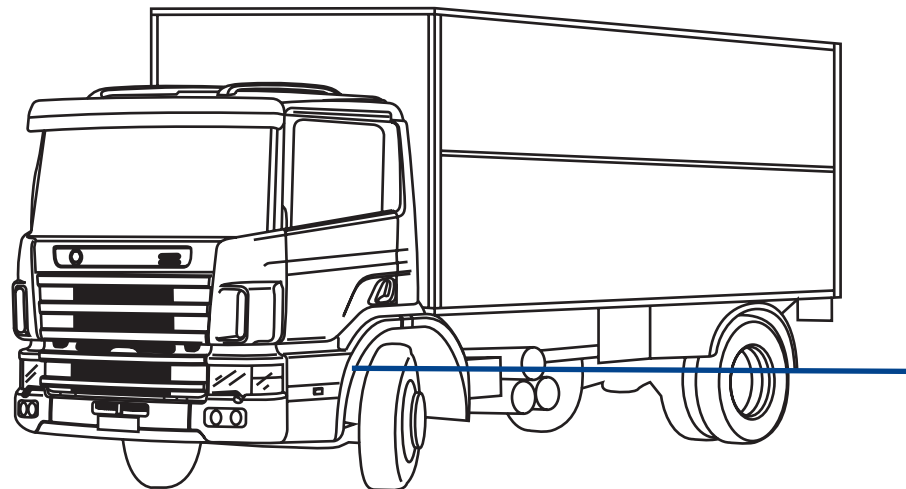

144/202 d-rh-rechts
144/203 s-lh-links

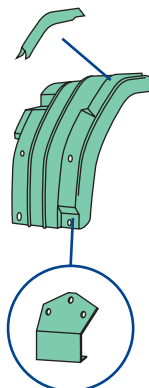

144/200
s-parte ant.
d-parte post.
lh-front section
rh-rear section
vorderer Teil li
Rueckseite re

144/210



144/200
O.E.M. 1485485



144/202
O.E.M. 1517650
144/203
O.E.M. 1517649



144/210
O.E.M. 1398873

SCANIA 144 CR

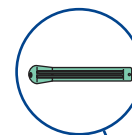
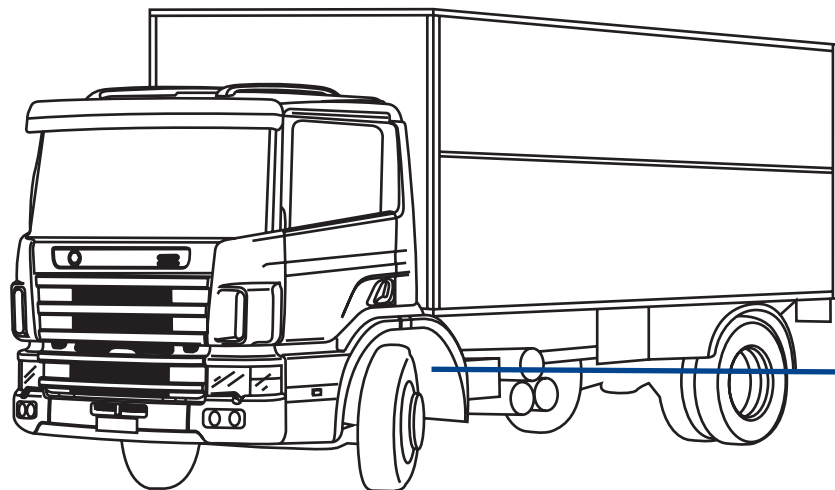

144/206 d-rh-rechts
144/207 s-lh-links

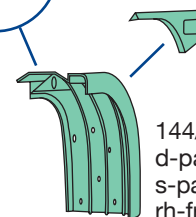

144/204
d-parte ant.
s-parte post.
rh-front section
lh-rear section
vorderer Teil re
Rueckseite li



144/204
O.E.M. 1485486



144/206
O.E.M. 1364666
144/207
O.E.M. 1364665



144/220
O.E.M. 1479924

applicabile a | suitable to | verwendbar für:

SCANIA 144 CR

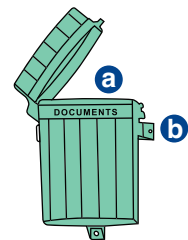
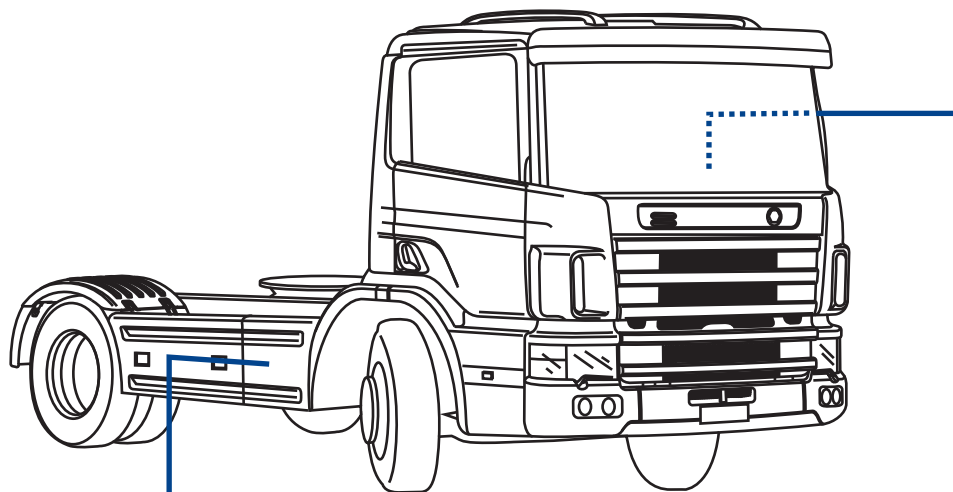

PDS/360

PDS/360

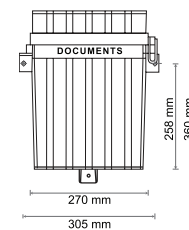

144/500
d-rh-rechts
senza staffe
without brackets
ohne Halter

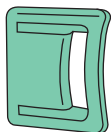

144/500
O.E.M. 1496659



PDS/360
O.E.M. -

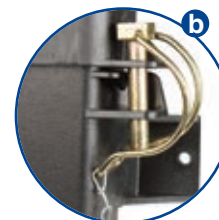

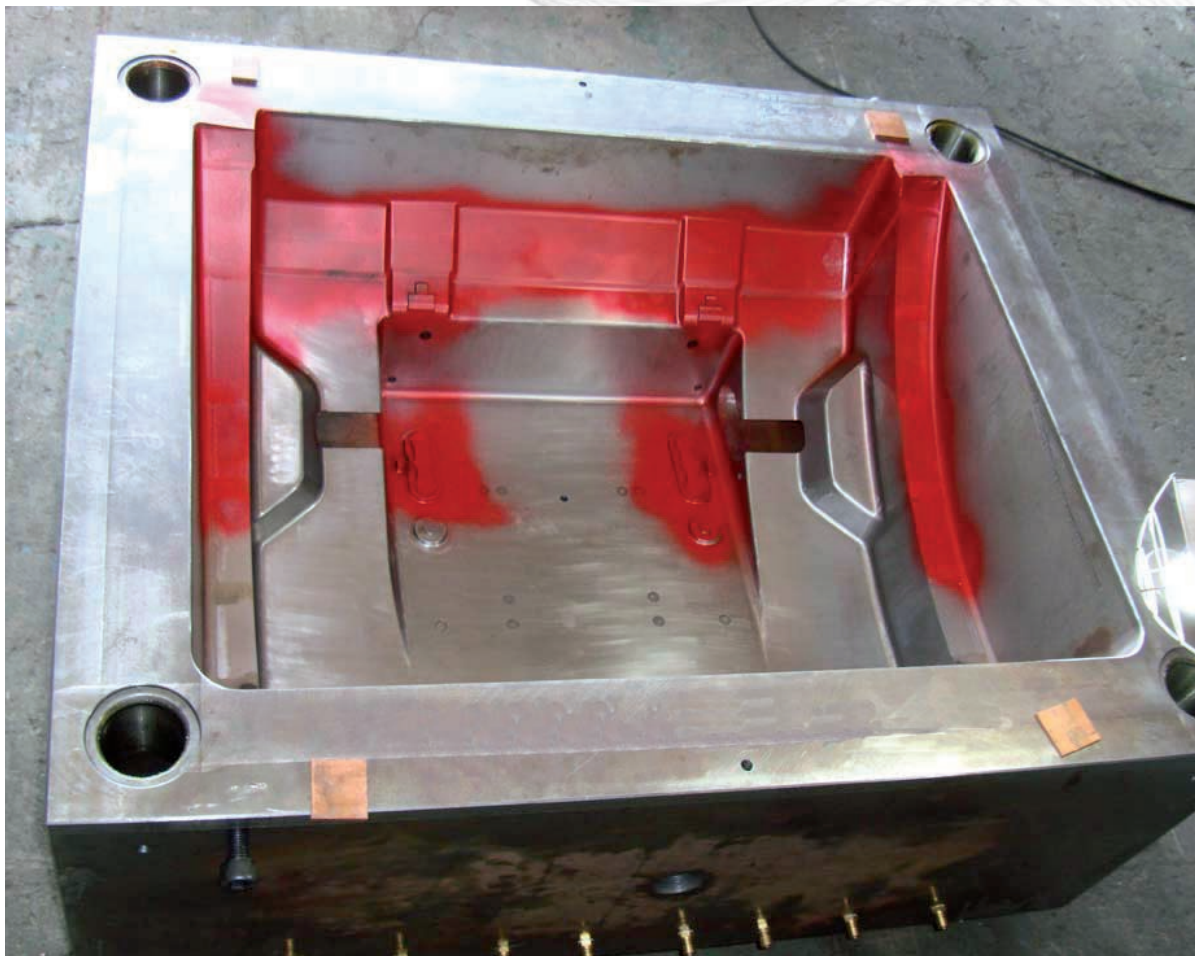

IT Stampo per lo stampaggio ad iniezione di un semiparafango posteriore

EN Mould for the production of the rear mudguard

DE Form zum Spritzgießen des Hinterachskotflügels

applicabile a | suitable to | verwendbar für:

SCANIA 144 CR

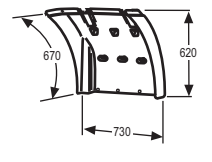
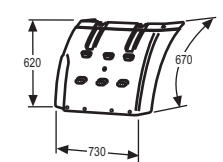
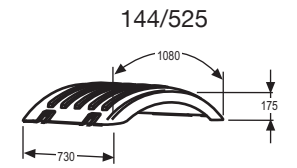
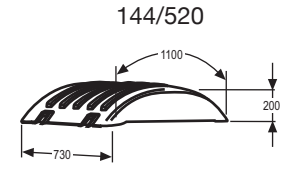
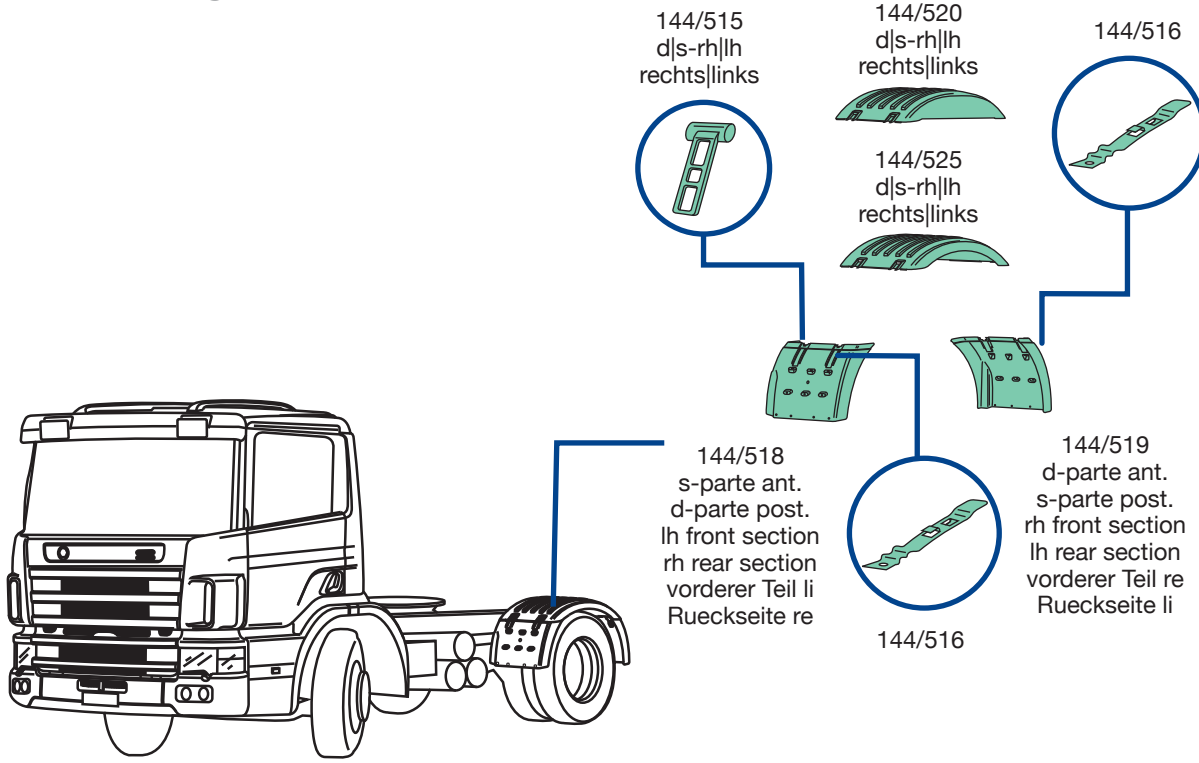

144/515
O.E.M. 1383858



144/516
O.E.M. 2056867

144/520
 O.E.M. 1357601
 d|s-rh|lh-rechts|links
 grigio, circolare, senza cinghietti
 grey, circular, without stretchers
 grau, halbrund, ohne Spanngummi



144/519
 O.E.M. 1357599
 d|s-rh|lh-rechts|links
 grigio, senza anti-spray
 grey, without anti-spray
 grau, ohne Spritzschutz



144/518
 O.E.M. 1357600
 d|s-rh|lh-rechts|links
 grigio
 grey
 grau

144/525
 O.E.M. 1395276
 d|s-rh|lh-rechts|links
 grigio, semipiatta, senza cinghietti
 grey, semi-flat, without stretchers
 grau, halbfach, ohne Spanngummi



144/519

144/518

applicabile a | suitable to | verwendbar für:

SCANIA 144 CR

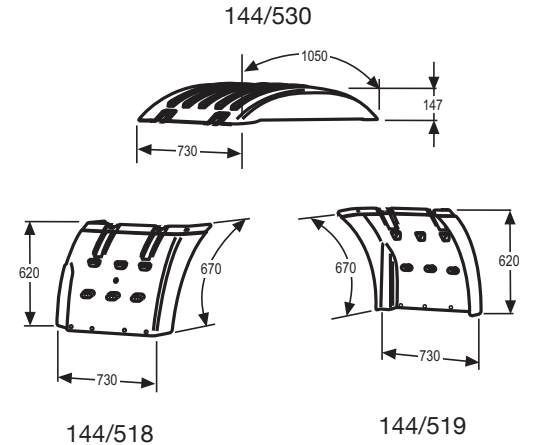
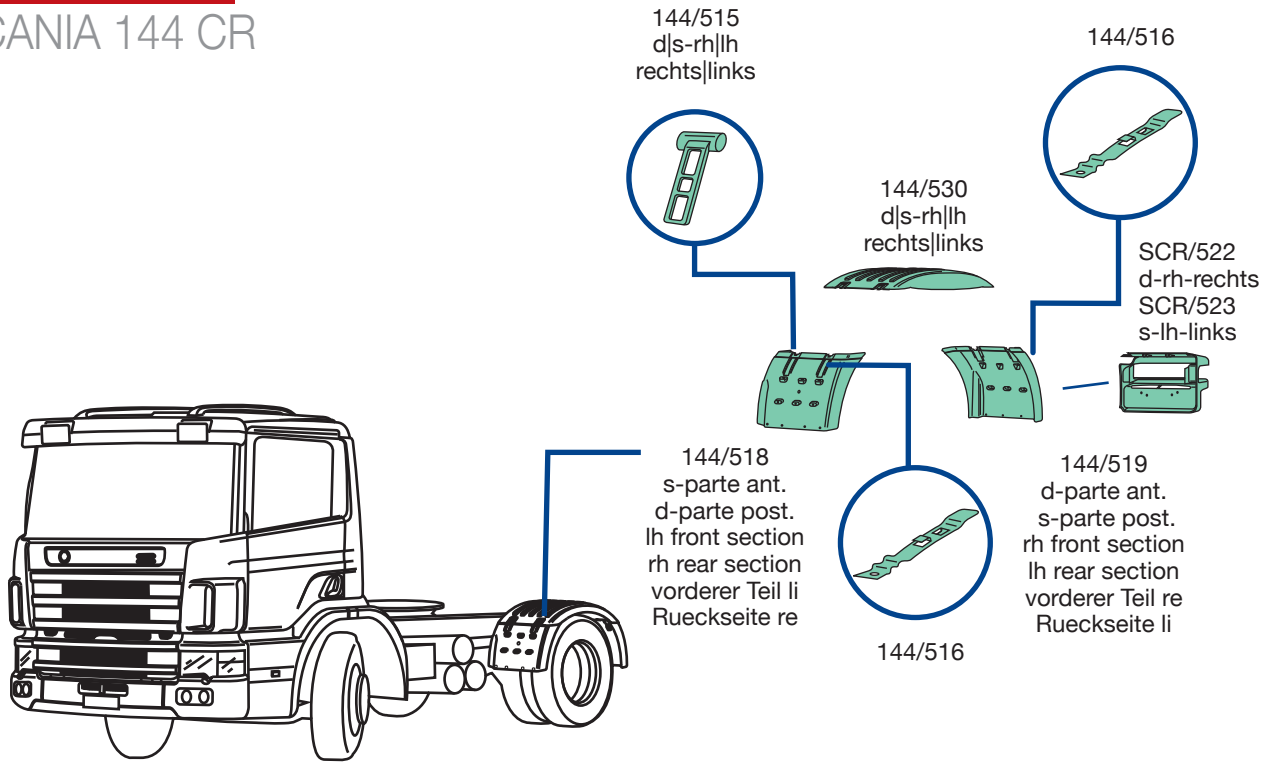

144/515
O.E.M. 1383858



144/516
O.E.M. 2056867



SCR/522
O.E.M. 2026621
SCR/523
O.E.M. 1362708

144/530
 O.E.M. 1357602
 d|s-rh|lh-rechts|links
 grigio, piatta, senza cinghietti
 grey, flat, without stretchers
 grau, flach, ohne Spanngummi

144/519
 O.E.M. 1357599
 d|s-rh|lh-rechts|links
 grigio, senza anti-spray
 grey, without anti-spray
 grau, ohne Spritzschutz

144/518
 O.E.M. 1357600
 d|s-rh|lh-rechts|links
 grigio
 grey
 grau



applicabile a | suitable to | verwendbar für:

SCANIA 144 CR

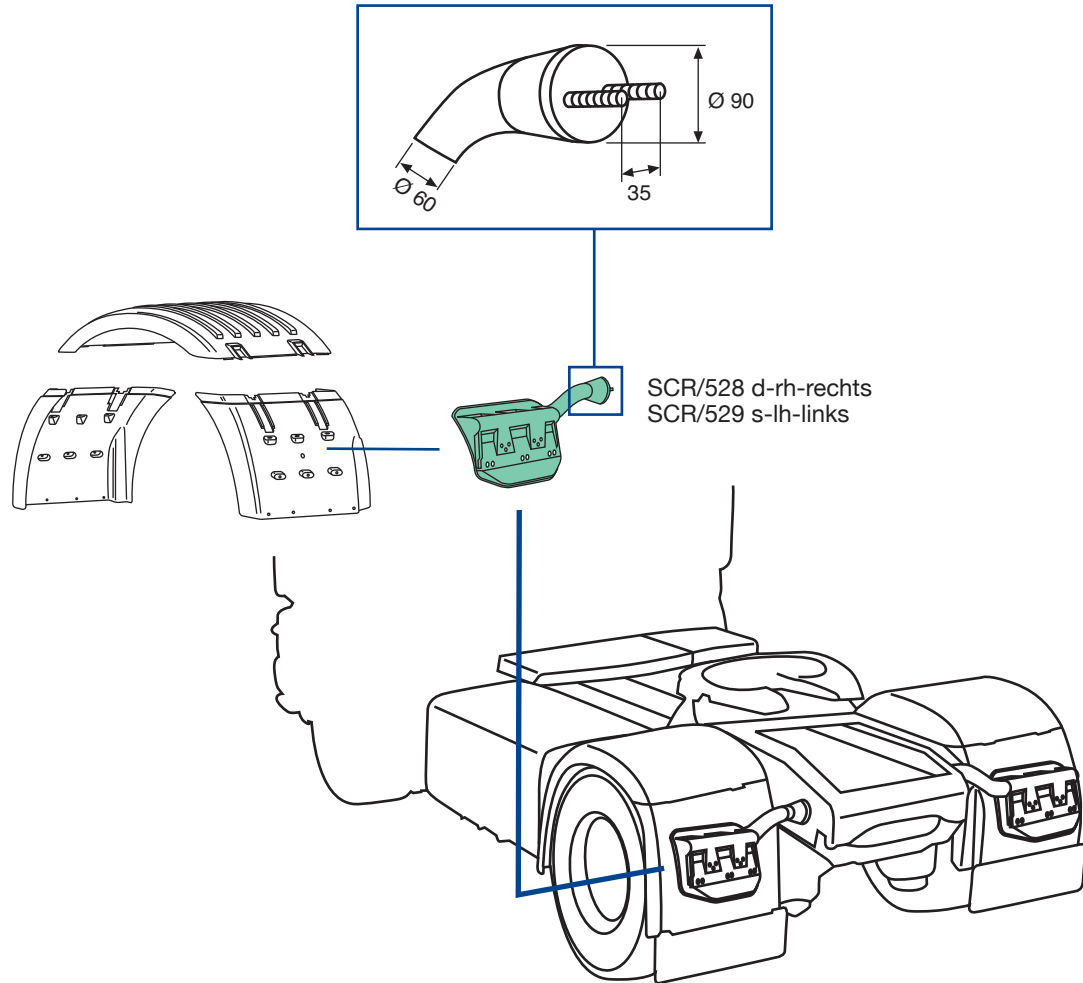



SCR/529
O.E.M. 2054603
posteriore sinistro
rear left
hinten links

SCR/528
O.E.M. 2054604
posteriore destro
rear right
hinten rechts



applicabile a | suitable to | verwendbar für:

SCANIA 144 CR

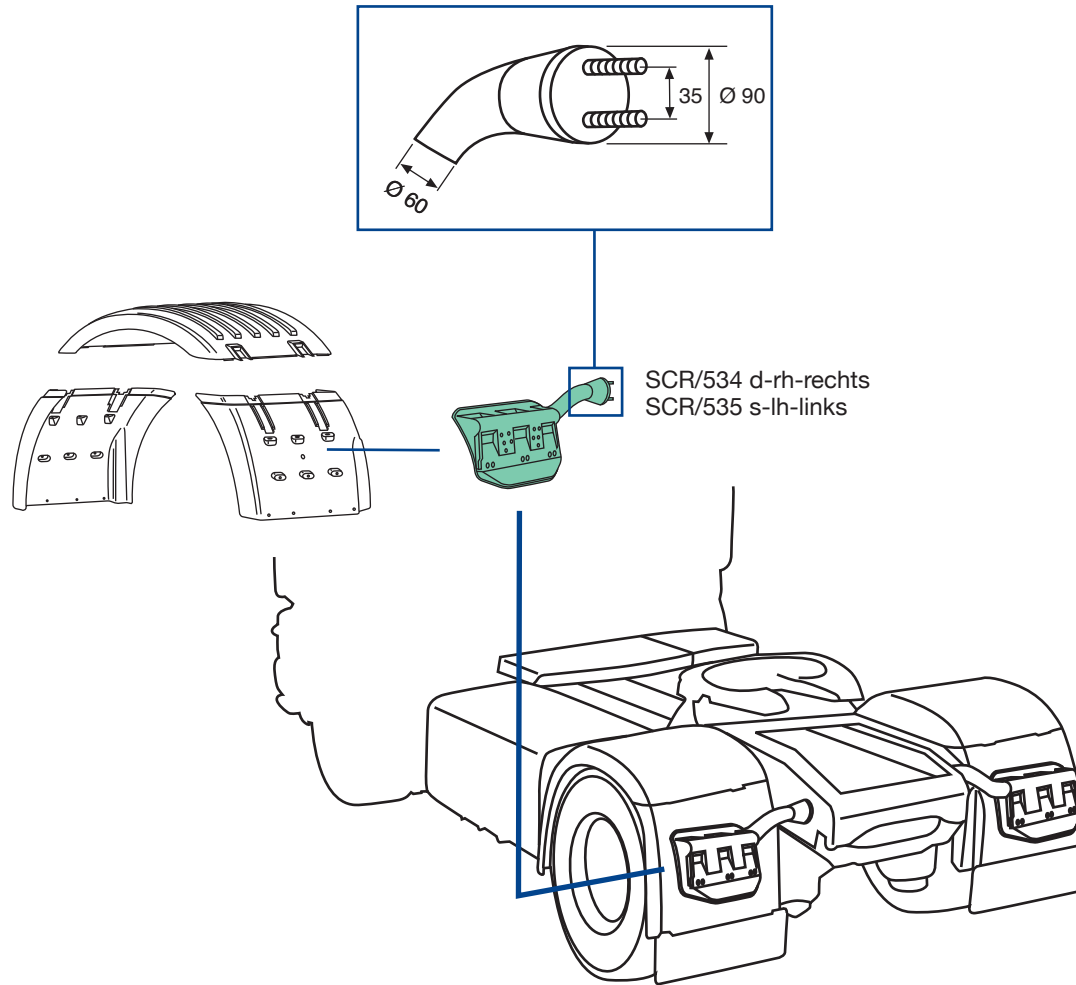



SCR/535
O.E.M. 2054601
posteriore sinistro
rear left
hinten links

SCR/534
O.E.M. 2054602
posteriore destro
rear right
hinten rechts



applicabile a | suitable to | verwendbar für:

SCANIA 144 CR

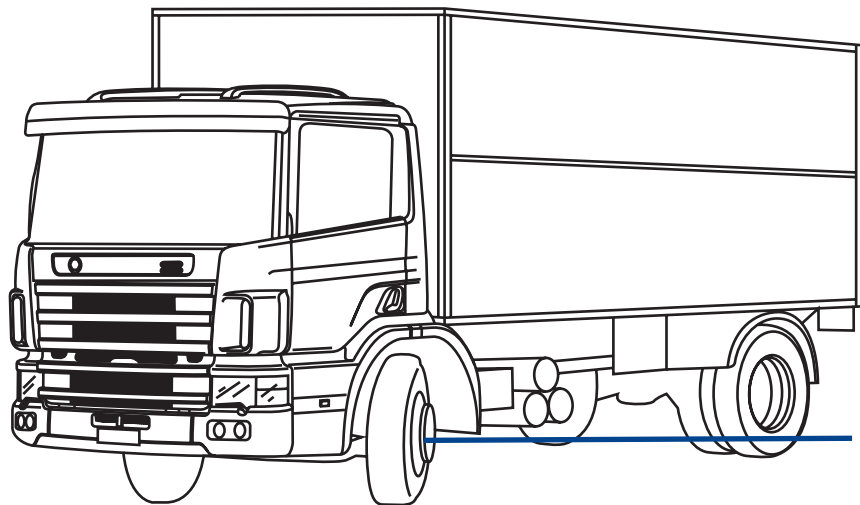

930/033

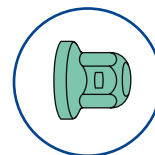

930/100
d-rh-rechts
930/101
s-lh-links

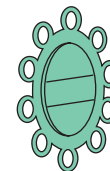

930/001
d-rh-rechts
930/002
s-lh-links

930/200
d|s-rh|lh
rechts|links



930/033
O.E.M. -



930/001
O.E.M. -
930/002
O.E.M. -



930/100
O.E.M. -
930/101
O.E.M. -



930/200
O.E.M. -

930/033 - Tappo copri Bullone - Bolt cover - Radmutterkappen

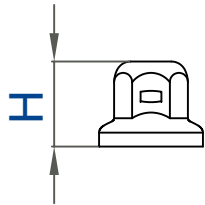

H	45 mm
Per bulloni \varnothing - bolt \varnothing	33 mm
Schlüsselweite \varnothing	
Colore	cromato-chrome-verchromt
Colours-Farbe	
Materiale-Material	acciaio inox-stainless steel Edelstahl
Kg	0,025

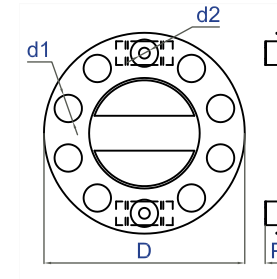

930/001 d-rh-rechts - 930/002 s-lh-links

D \varnothing 425 mm	P 50 mm
d1 nr. 10	d1 \varnothing 58 mm
d2 nr. 2	d2 \varnothing 23 mm
Ventilata	si-yes-Ja
Ventilated-Belüftet	
Colore	cromato e nero-chrome and black
Colours-Farbe	verchromt und schwarz
Materiale-Material	acciaio inox e plastica stainless steel and plastic Edelstahl und Kunststoff
Kg	1,230

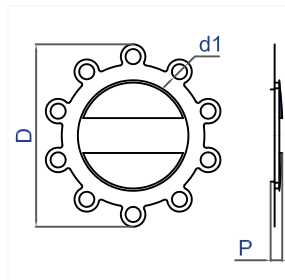

930/100 d-rh-rechts - 930/101 s-lh-links

D \varnothing 387 mm	P 30 mm
d1 nr. 10	d1 \varnothing 32 mm
Ventilata	si-yes-Ja
Ventilated-Belüftet	
Colore	cromato e nero-chrome and black
Colours-Farbe	verchromt und schwarz
Materiale-Material	acciaio inox e plastica stainless steel and plastic Edelstahl und Kunststoff
Kg	0,655

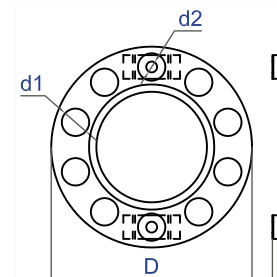

930/200 d|s-rh|lh-rechts|links

D \varnothing 425 mm	P 40 mm
d1 nr. 10	d1 \varnothing 58 mm
d2 nr. 2	d2 \varnothing 23 mm
Ventilata	no-nein
Ventilated-Belüftet	
Colore	cromato-chrome-verchromt
Colours-Farbe	
Materiale-Material	acciaio inox-stainless steel Edelstahl
Kg	1,155



IT Officina di riparazione
EN Workshop
DE Werkstatt



applicabile a | suitable to | verwendbar für

317

093

SCANIA 93 CP

P83-P93-P113 Intercooler

applicabile a | suitable to | verwendbar für:

SCANIA 93 CP

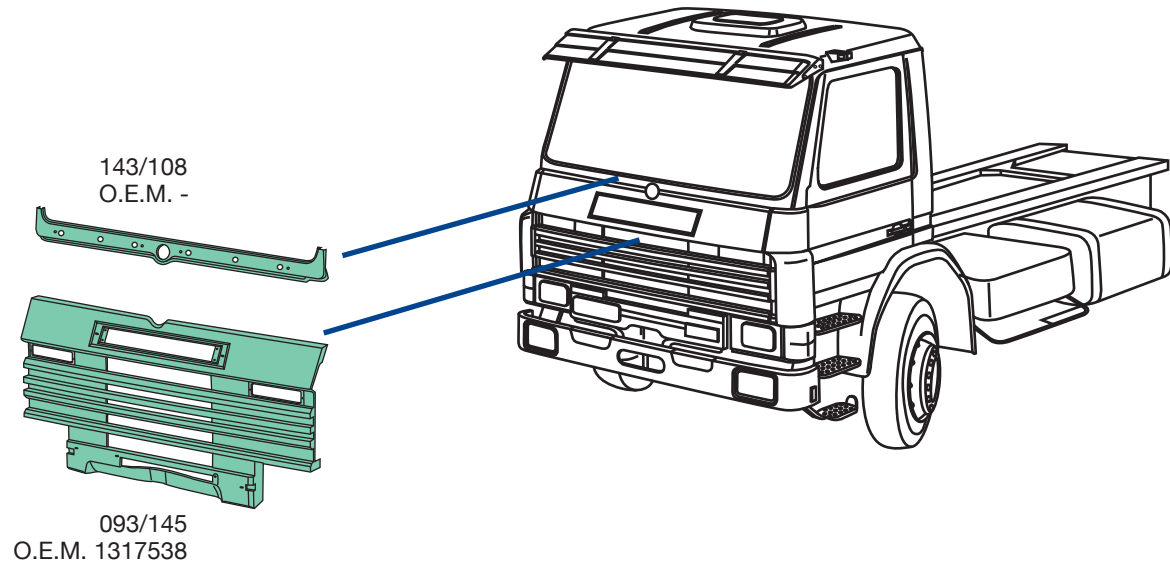

SCANIA 93 CP

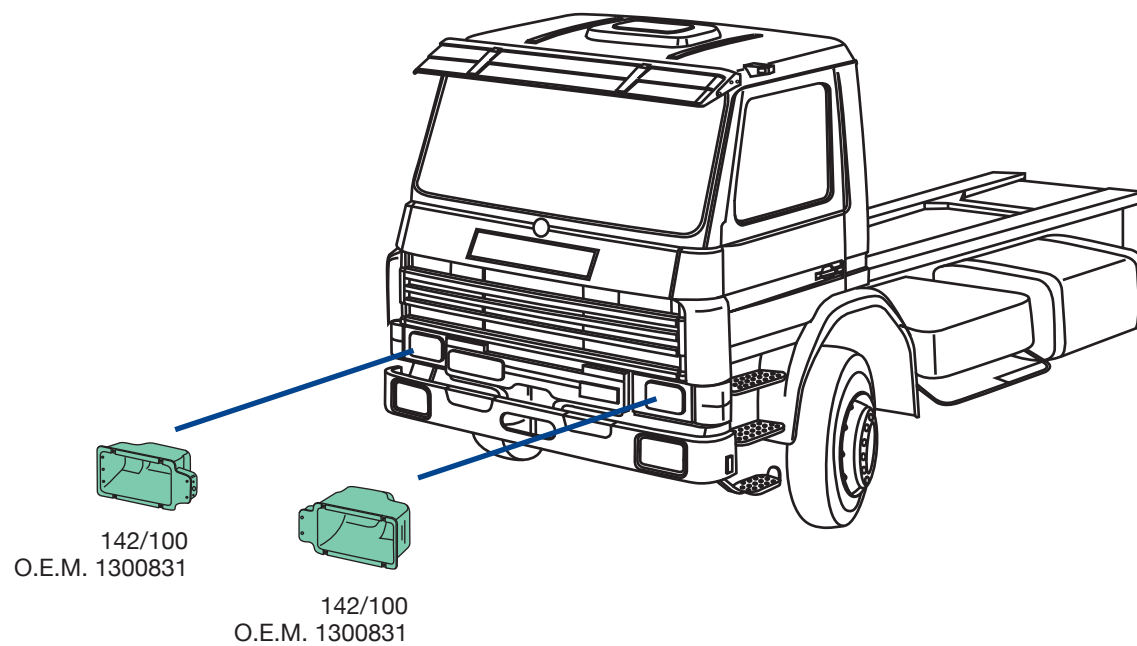

applicabile a | suitable to | verwendbar für:

SCANIA 93 CP

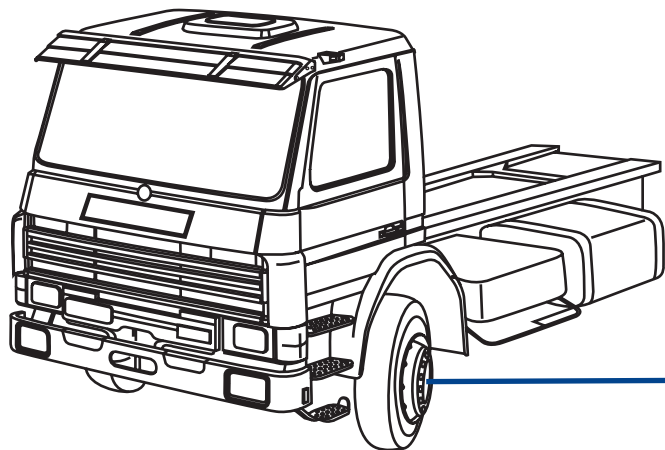

930/033
O.E.M. -

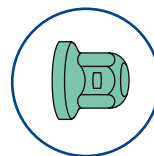

930/001 d-rh-rechts
O.E.M. -
930/002 s-lh-links
O.E.M. -



930/200
O.E.M. -
d|s-rh|lh
rechts|links

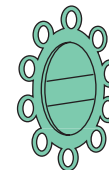

930/100 d-rh-rechts
O.E.M. -
930/101 s-lh-links
O.E.M. -

930/033 - Tappo copri Bullone - Bolt cover - Radmutterkappen

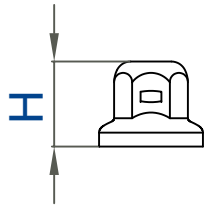

H	45 mm
Per bulloni \varnothing - bolt \varnothing	33 mm
Schlüsselweite \varnothing	
Colore	cromato-chrome-verchromt
Colours-Farbe	
Materiale-Material	acciaio inox-stainless steel Edelstahl
Kg	0,025

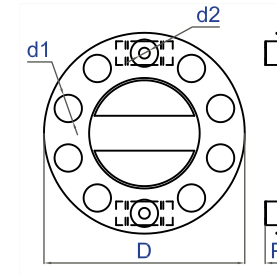

930/001 d-rh-rechts - 930/002 s-lh-links

D \varnothing 425 mm	P 50 mm
d1 nr. 10	d1 \varnothing 58 mm
d2 nr. 2	d2 \varnothing 23 mm
Ventilata	si-yes-Ja
Ventilated-Belüftet	
Colore	cromato e nero-chrome and black
Colours-Farbe	verchromt und schwarz
Materiale-Material	acciaio inox e plastica stainless steel and plastic Edelstahl und Kunststoff
Kg	1,230

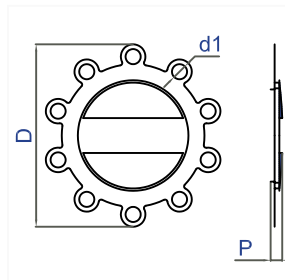

930/100 d-rh-rechts - 930/101 s-lh-links

D \varnothing 387 mm	P 30 mm
d1 nr. 10	d1 \varnothing 32 mm
Ventilata	si-yes-Ja
Ventilated-Belüftet	
Colore	cromato e nero-chrome and black
Colours-Farbe	verchromt und schwarz
Materiale-Material	acciaio inox e plastica stainless steel and plastic Edelstahl und Kunststoff
Kg	0,655

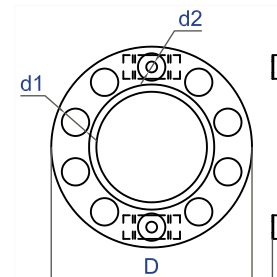

930/200 d|s-rh|lh-rechts|links

D \varnothing 425 mm	P 40 mm
d1 nr. 10	d1 \varnothing 58 mm
d2 nr. 2	d2 \varnothing 23 mm
Ventilata	no-nein
Ventilated-Belüftet	
Colore	cromato-chrome-verchromt
Colours-Farbe	
Materiale-Material	acciaio inox-stainless steel Edelstahl
Kg	1,155

applicabile a | suitable to | verwendbar für:

SCANIA 93 CP

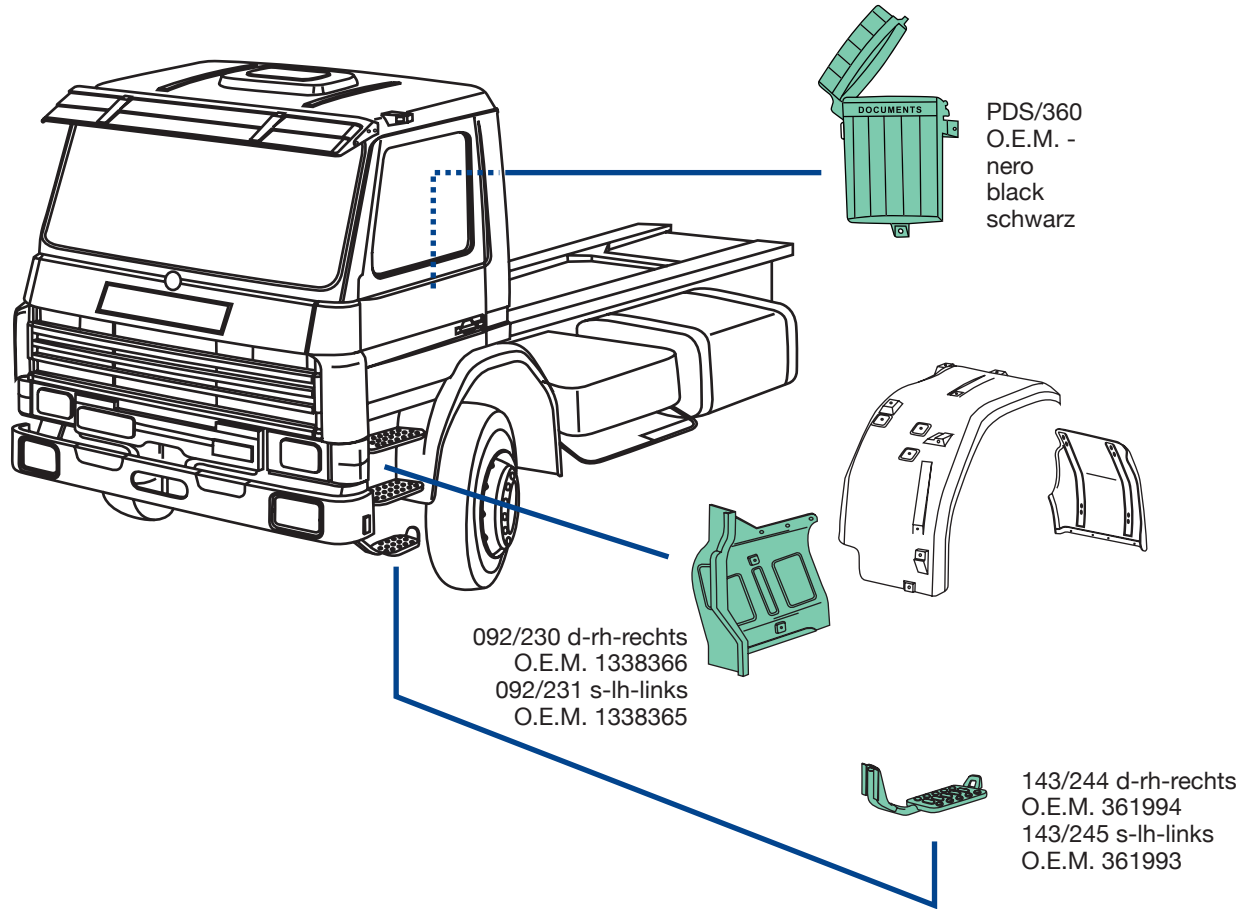

PDS/360

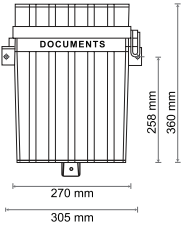



applicabile a | suitable to | verwendbar für 323

143
SCANIA 143 CR

R93-R113-R143 Intercooler

applicabile a | suitable to | verwendbar für:

SCANIA 143 CR

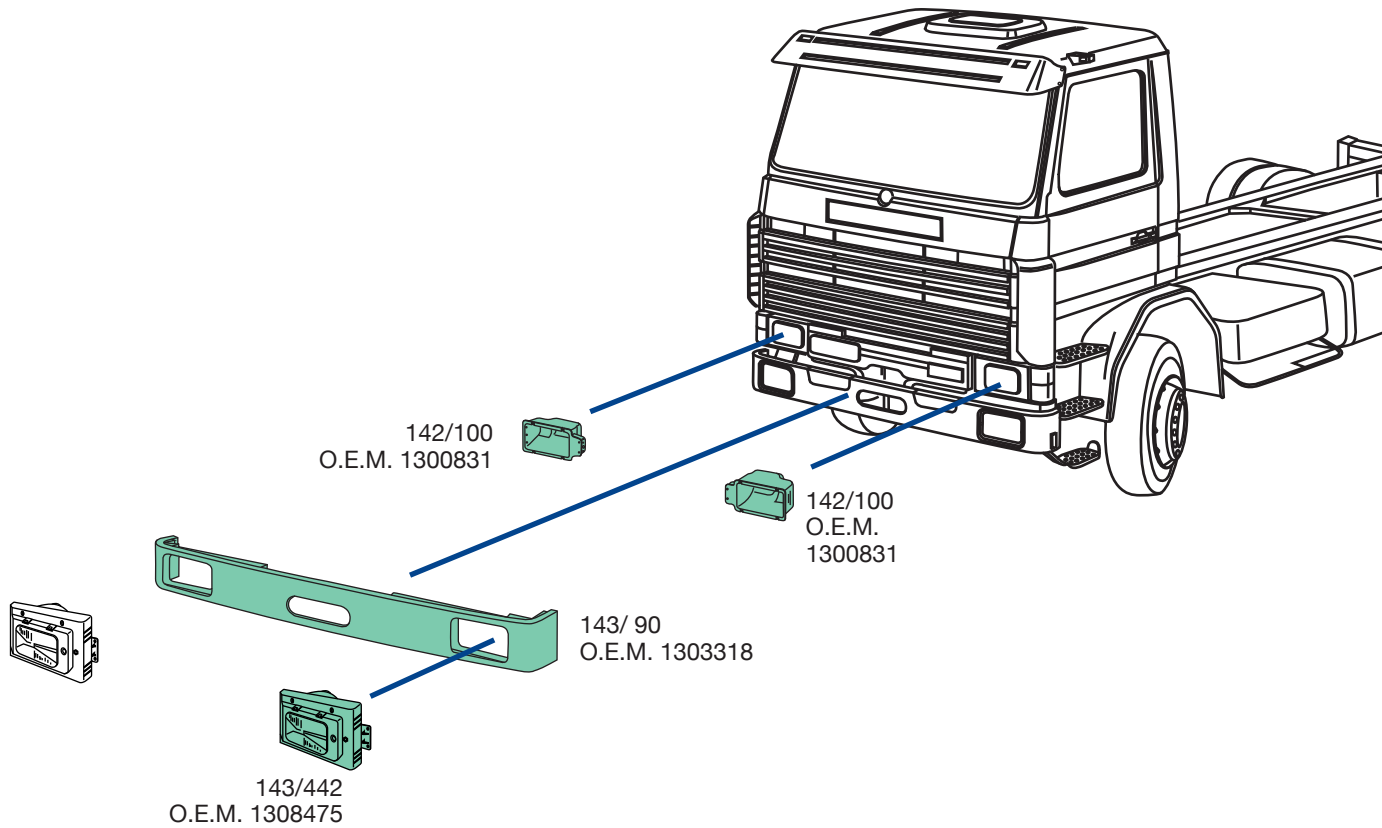

SCANIA 143 CR

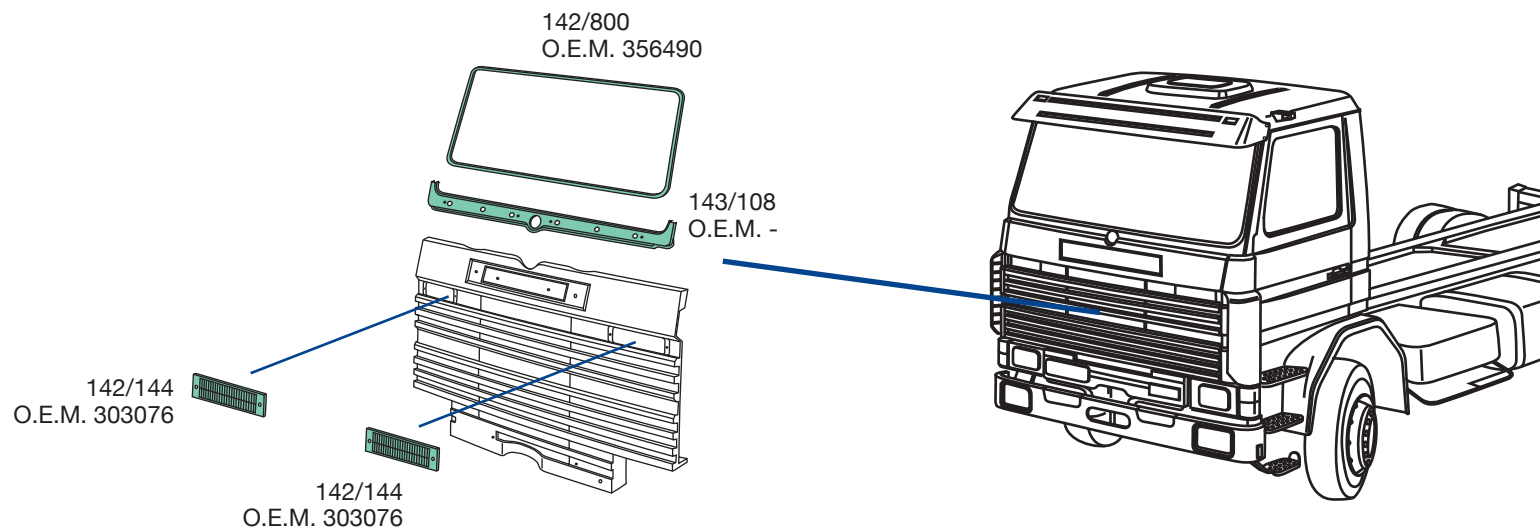

applicabile a | suitable to | verwendbar für:

SCANIA 143 CR

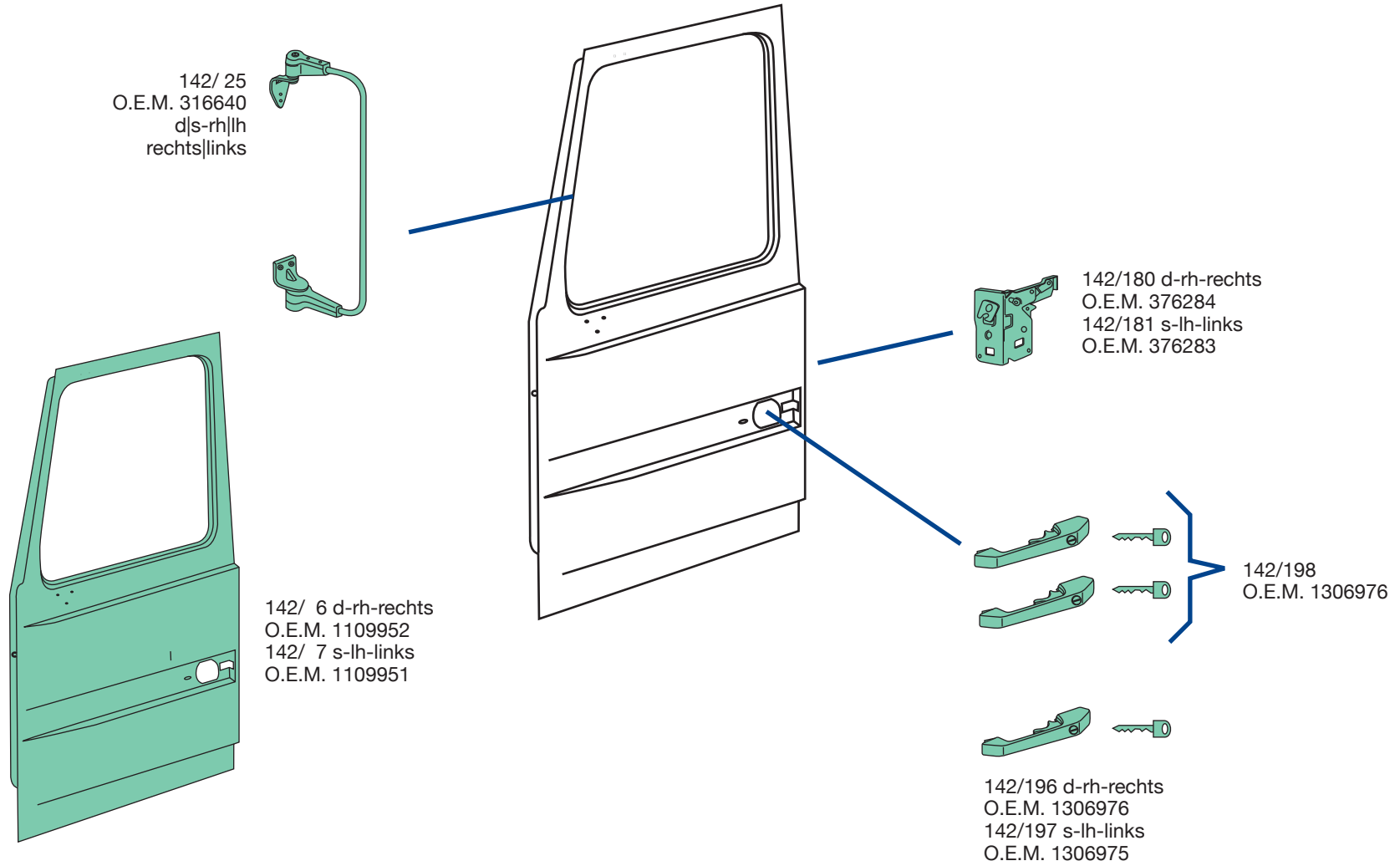

SCANIA 143 CR

142/182 d-rh-rechts
O.E.M. 296834
142/183 s-lh-links
O.E.M. 296833

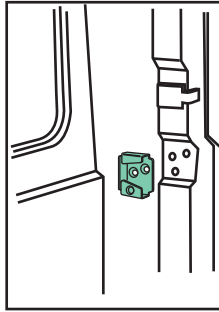

142/177
O.E.M. 524533
d|s-rh|lh-rechts|links

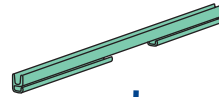

142/170
O.E.M. 356540
d|s-rh|lh-rechts|links

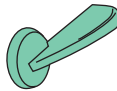

142/166
O.E.M. 376116
d|s-rh|lh-rechts|links



142/ 9
O.E.M. 356942
d|s-rh|lh-rechts|links

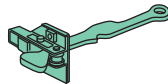

142/164 d-rh-rechts
O.E.M. 524784
142/165 s-lh-links
O.E.M. 524783

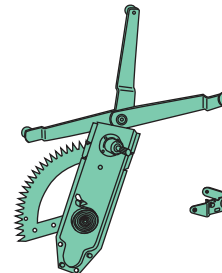

142/174 d-rh-rechts
O.E.M. 524796
142/175 s-lh-links
O.E.M. 524795

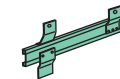

142/172
O.E.M. 336938
d|s-rh|lh-rechts|links



applicabile a | suitable to | verwendbar für:

SCANIA 143 CR

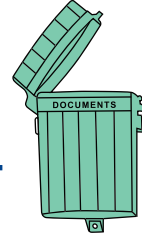
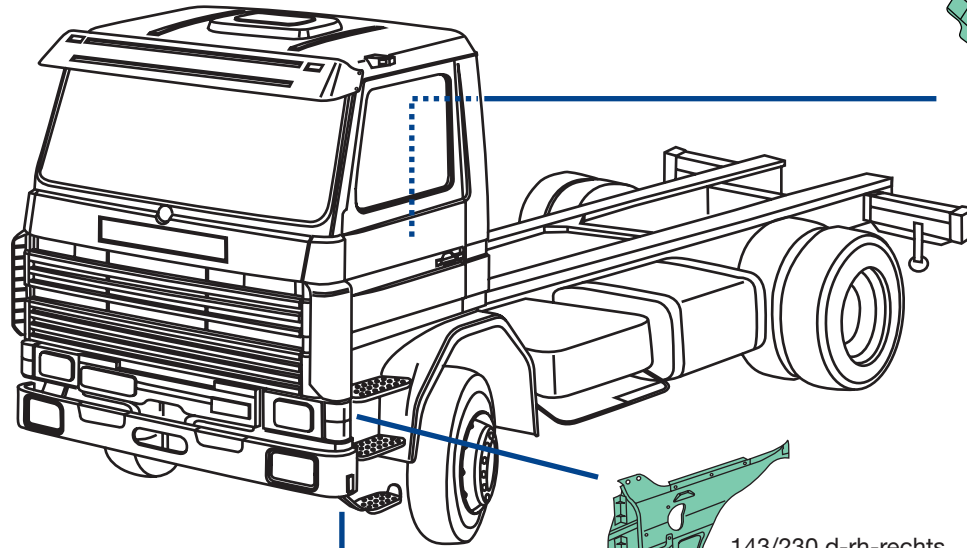

PDS/360
O.E.M. -
nero
black
schwarz

PDS/360

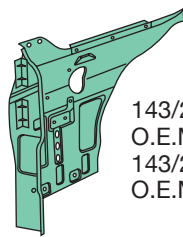
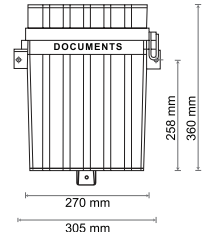

143/230 d-rh-rechts
O.E.M. 1338378
143/231 s-lh-links
O.E.M. 1338379



143/244 d-rh-rechts
O.E.M. 1338378
143/245 s-lh-links
O.E.M. 361993



143/240 d-rh-rechts
O.E.M. 361020
143/241 s-lh-links
O.E.M. 361019

SCANIA 143 CR

143/520
O.E.M. 1313594
d|s-rh||h-rechts|links
senza antispray
without antispray
ohne Spritzschutz

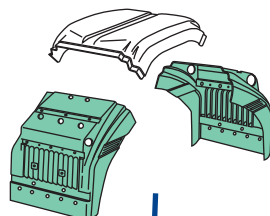

143/520
O.E.M. 1313594
d|s-rh||h-rechts|links
senza antispray
without antispray
ohne Spritzschutz

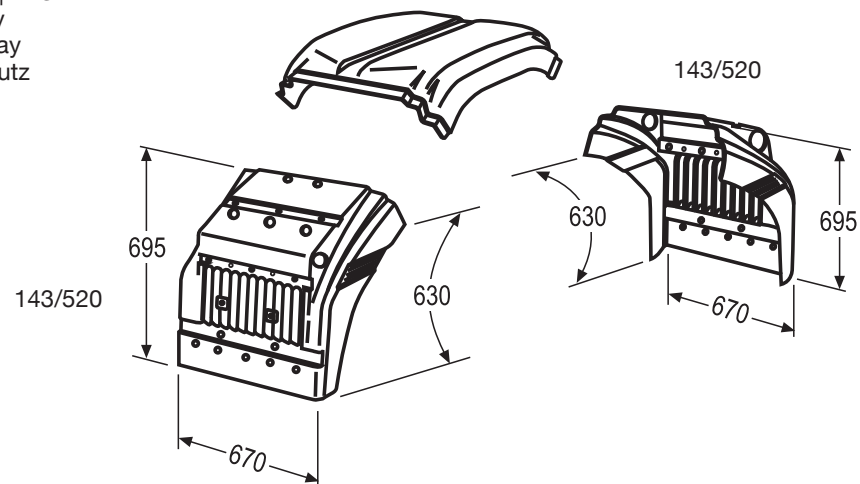
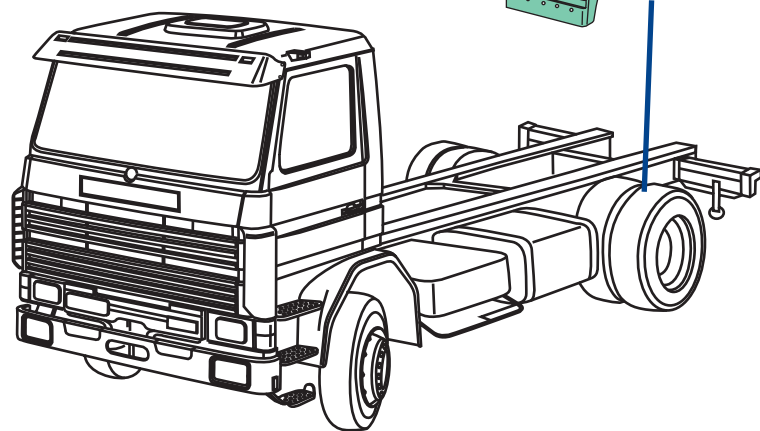

applicabile a | suitable to | verwendbar für:

SCANIA 143 CR

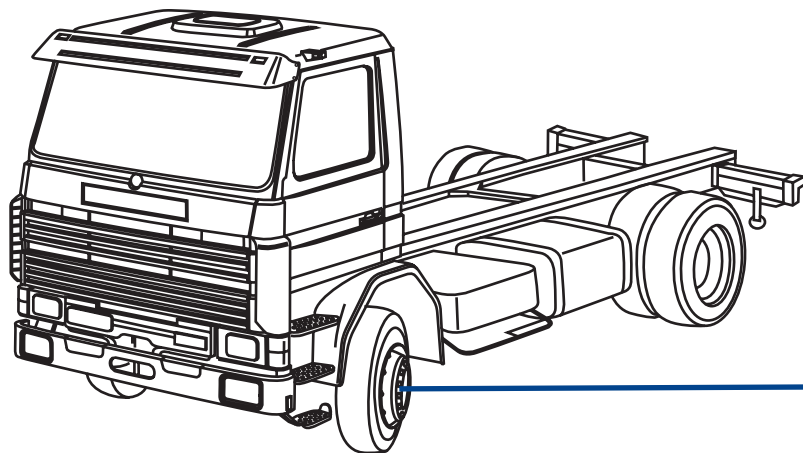

930/033
O.E.M. -

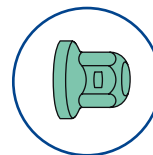

930/001 d-rh-rechts
O.E.M. -
930/002 s-lh-links
O.E.M. -



930/200
O.E.M. -
d|s-rh|lh
rechts|links

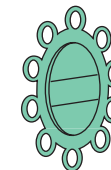

930/100 d-rh-rechts
O.E.M. -
930/101 s-lh-links
O.E.M. -

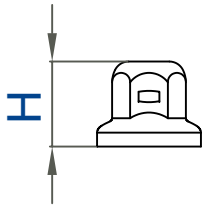
930/033 - Tappo copri Bullone - Bolt cover - Radmutterkappen

H	45 mm
Per bulloni \varnothing - bolt \varnothing	33 mm
Schlüsselweite \varnothing	
Colore	cromato-chrome-verchromt
Colours-Farbe	
Materiale-Material	acciaio inox-stainless steel Edelstahl
Kg	0,025

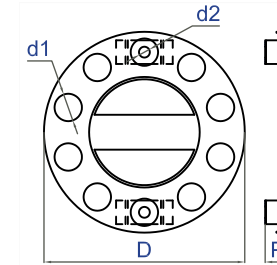
**930/001 d-rh-rechts - 930/002 s-lh-links**

D \varnothing 425 mm	P 50 mm
d1 nr. 10	d1 \varnothing 58 mm
d2 nr. 2	d2 \varnothing 23 mm
Ventilata	si-yes-Ja
Ventilated-Belüftet	
Colore	cromato e nero-chrome and black
Colours-Farbe	verchromt und schwarz
Materiale-Material	acciaio inox e plastica stainless steel and plastic Edelstahl und Kunststoff
Kg	1,230

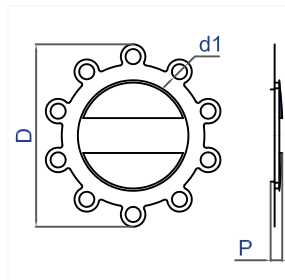
**930/100 d-rh-rechts - 930/101 s-lh-links**

D \varnothing 387 mm	P 30 mm
d1 nr. 10	d1 \varnothing 32 mm
Ventilata	si-yes-Ja
Ventilated-Belüftet	
Colore	cromato e nero-chrome and black
Colours-Farbe	verchromt und schwarz
Materiale-Material	acciaio inox e plastica stainless steel and plastic Edelstahl und Kunststoff
Kg	0,655

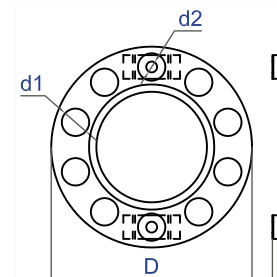
**930/200 d|s-rh|lh-rechts|links**

D \varnothing 425 mm	P 40 mm
d1 nr. 10	d1 \varnothing 58 mm
d2 nr. 2	d2 \varnothing 23 mm
Ventilata	no-nein
Ventilated-Belüftet	
Colore	cromato-chrome-verchromt
Colours-Farbe	
Materiale-Material	acciaio inox-stainless steel Edelstahl
Kg	1,155

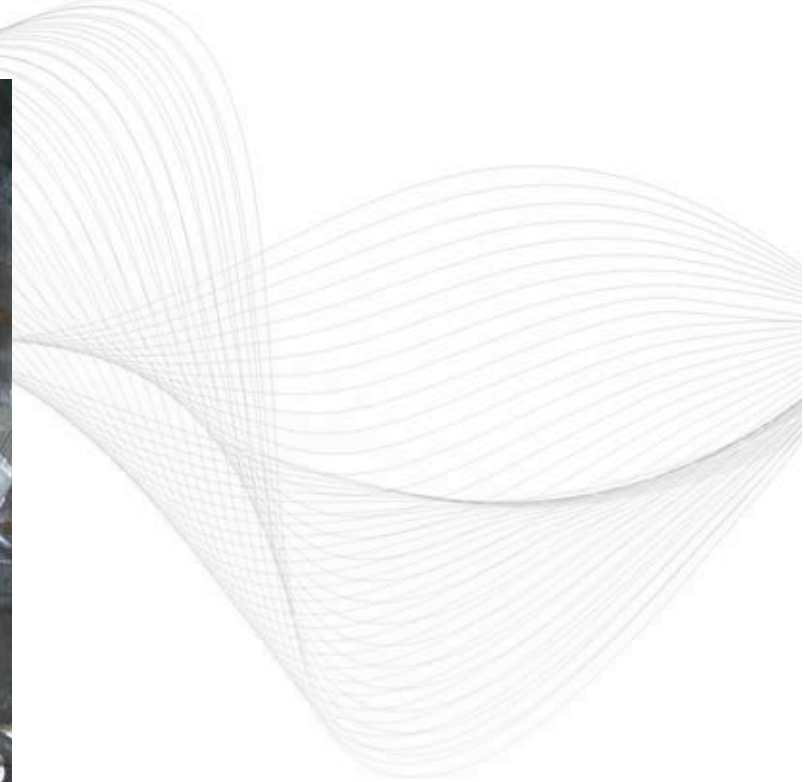
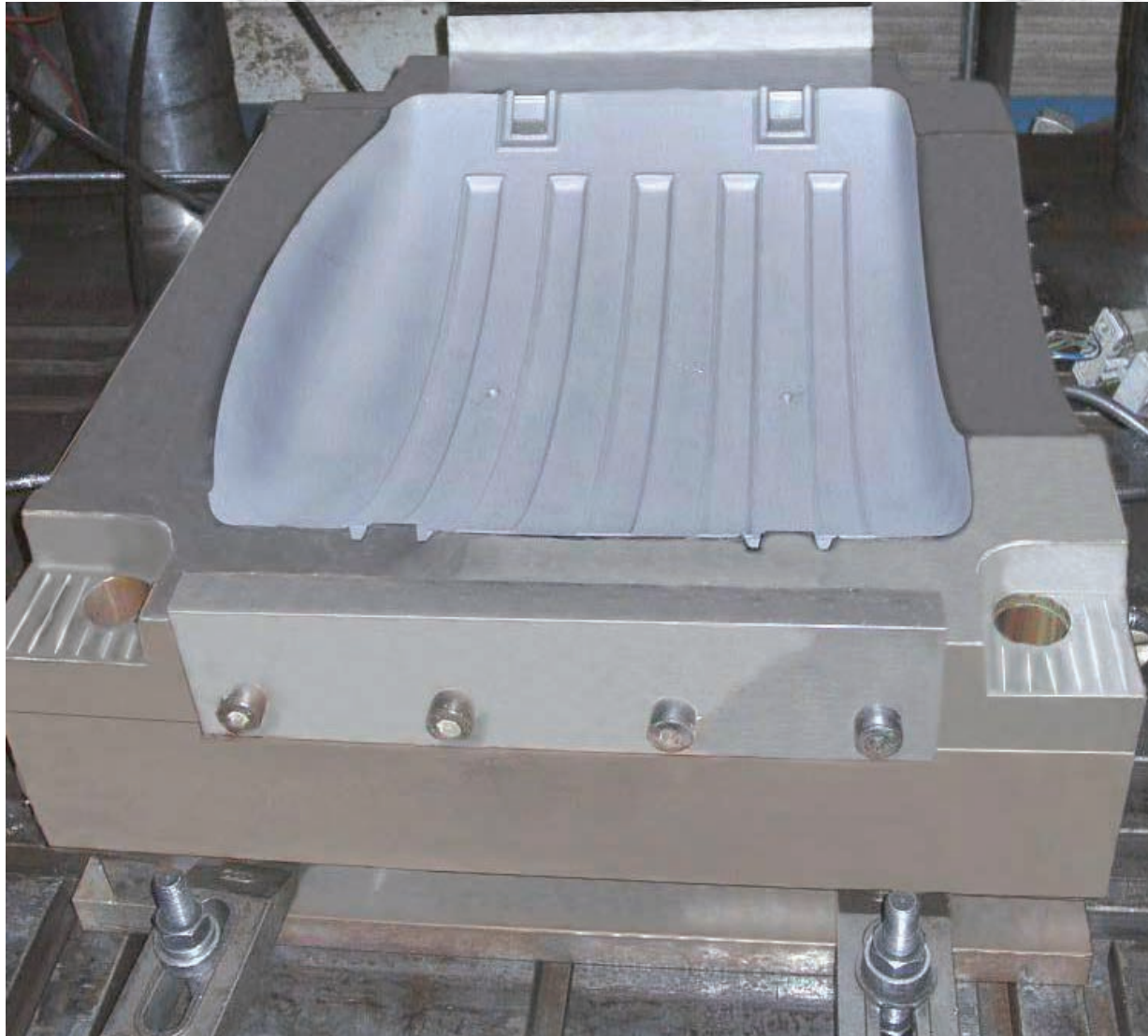

- ▲
- IT Stampo a iniezione per la produzione della calotta del veicolo Scania (Cod. Covind 144/520)
- EN Injection mould for the production of the top guard for the Scania vehicles (Cod. Covind 144/520)
- DE Injektionsstahlform für die Produktion der Scania Kotflügel (Covind Nr. 144/520)



applicabile a | suitable to | verwendbar für 333

092
SCANIA 92 CP

P82-P92-P112H

applicabile a | suitable to | verwendbar für:

SCANIA 92 CP

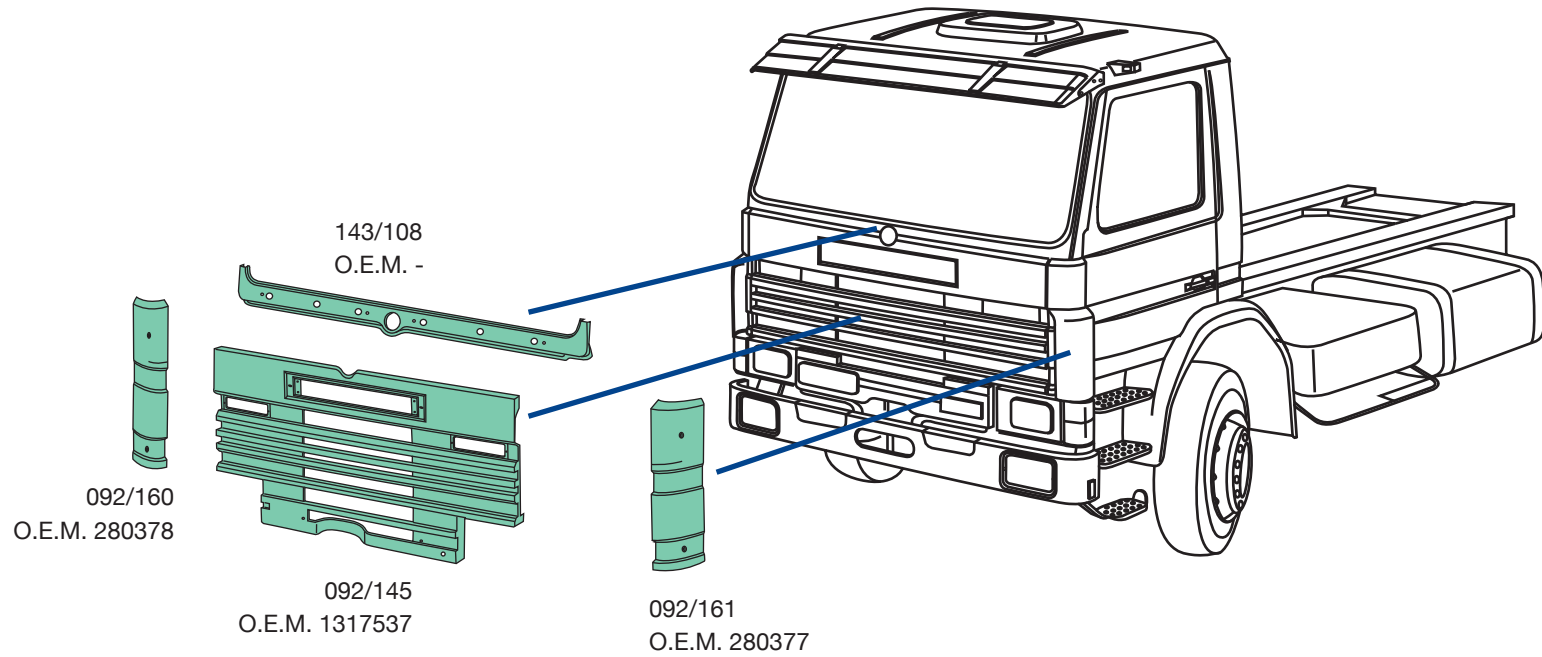

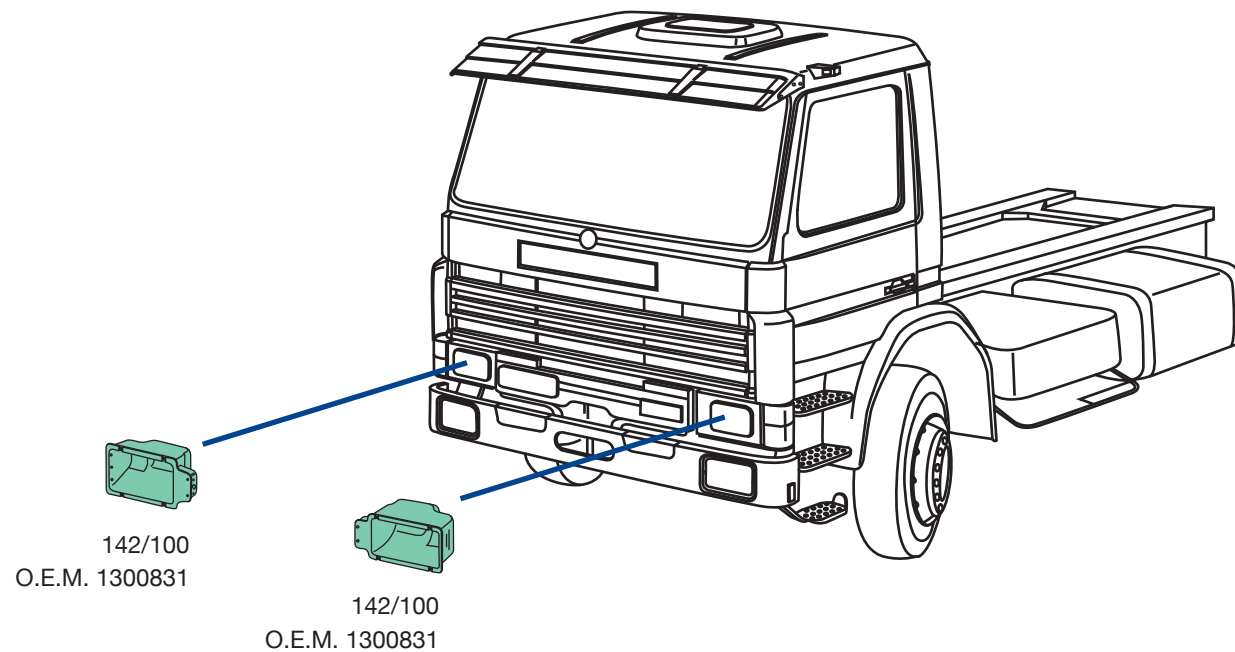

applicabile a | suitable to | verwendbar für:

SCANIA 92 CP

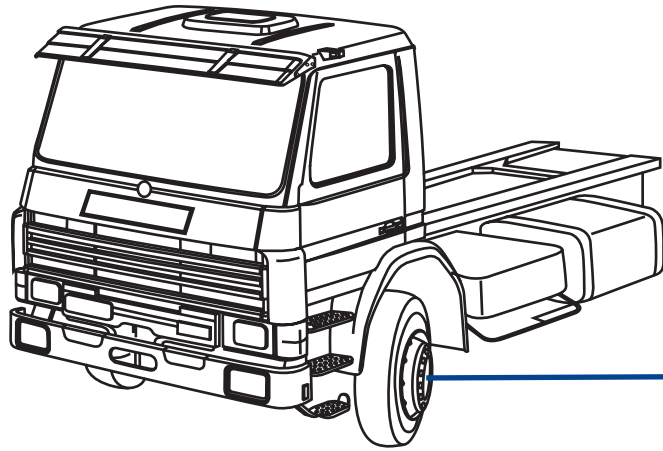

930/033
O.E.M. -

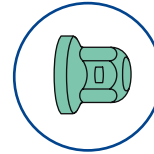

930/001 d-rh-rechts
O.E.M. -
930/002 s-lh-links
O.E.M. -



930/200
O.E.M. -
d|s-rh|lh
rechts|links

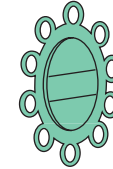

930/100 d-rh-rechts
O.E.M. -
930/101 s-lh-links
O.E.M. -

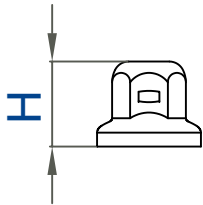
930/033 - Tappo copri Bullone - Bolt cover - Radmutterkappen

H	45 mm
Per bulloni \varnothing - bolt \varnothing	33 mm
Schlüsselweite \varnothing	
Colore	cromato-chrome-verchromt
Colours-Farbe	
Materiale-Material	acciaio inox-stainless steel Edelstahl
Kg	0,025

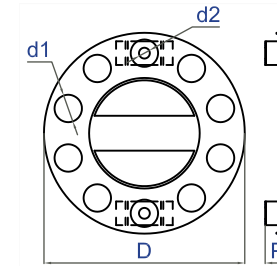
**930/001 d-rh-rechts - 930/002 s-lh-links**

D \varnothing 425 mm	P 50 mm
d1 nr. 10	d1 \varnothing 58 mm
d2 nr. 2	d2 \varnothing 23 mm
Ventilata	si-yes-Ja
Ventilated-Belüftet	
Colore	cromato e nero-chrome and black
Colours-Farbe	verchromt und schwarz
Materiale-Material	acciaio inox e plastica stainless steel and plastic Edelstahl und Kunststoff
Kg	1,230

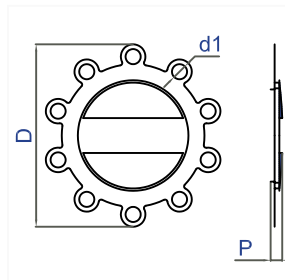
**930/100 d-rh-rechts - 930/101 s-lh-links**

D \varnothing 387 mm	P 30 mm
d1 nr. 10	d1 \varnothing 32 mm
Ventilata	si-yes-Ja
Ventilated-Belüftet	
Colore	cromato e nero-chrome and black
Colours-Farbe	verchromt und schwarz
Materiale-Material	acciaio inox e plastica stainless steel and plastic Edelstahl und Kunststoff
Kg	0,655

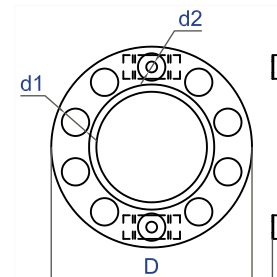
**930/200 d|s-rh|lh-rechts|links**

D \varnothing 425 mm	P 40 mm
d1 nr. 10	d1 \varnothing 58 mm
d2 nr. 2	d2 \varnothing 23 mm
Ventilata	no-nein
Ventilated-Belüftet	
Colore	cromato-chrome-verchromt
Colours-Farbe	
Materiale-Material	acciaio inox-stainless steel Edelstahl
Kg	1,155

applicabile a | suitable to | verwendbar für:

SCANIA 92 CP

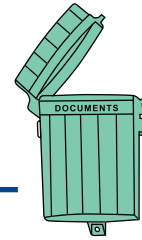
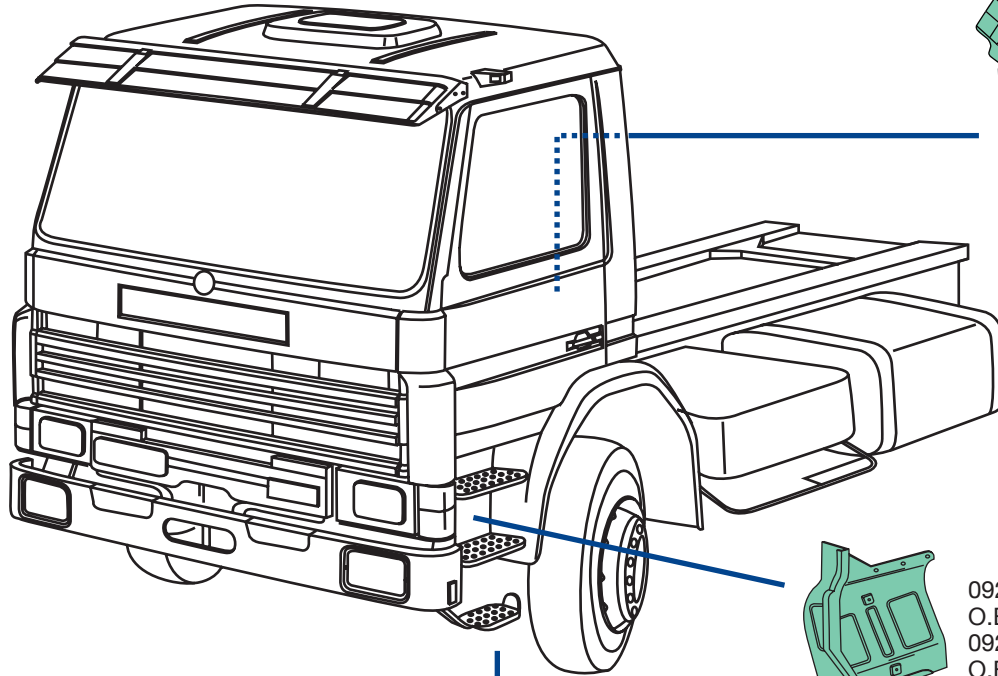

PDS/360
O.E.M. -
nero
black
schwarz

PDS/360

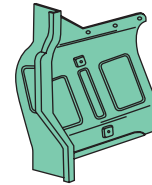
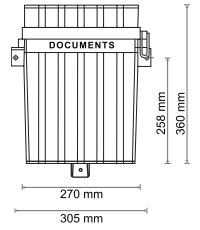

092/230 d-rh-rechts
O.E.M. 1338366
092/231 s-lh-links
O.E.M. 1338365



143/244 d-rh-rechts
O.E.M. 361994
143/245 s-lh-links
O.E.M. 361993



applicabile a | suitable to | verwendbar für 339

142
SCANIA 142 CR

R92-R112-R142

applicabile a | suitable to | verwendbar für:

SCANIA 142 CR

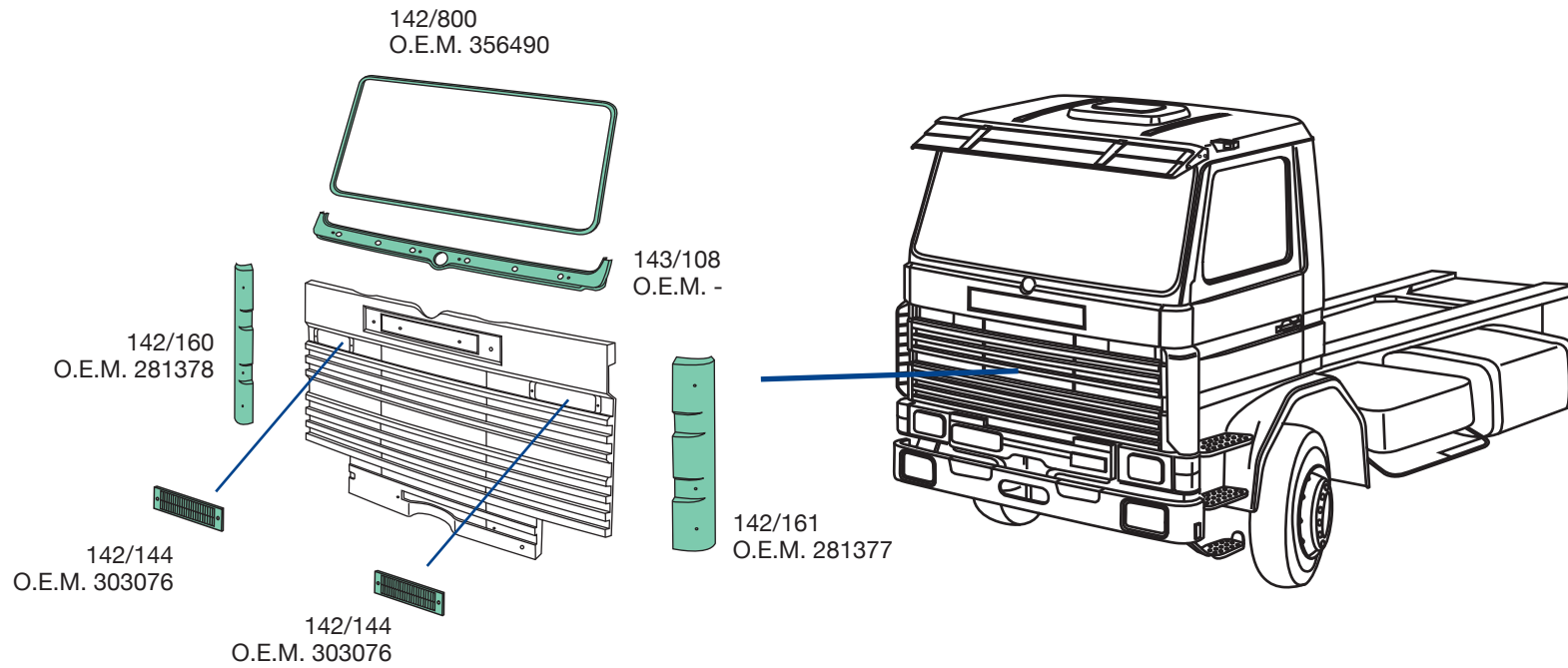

SCANIA 142 CR

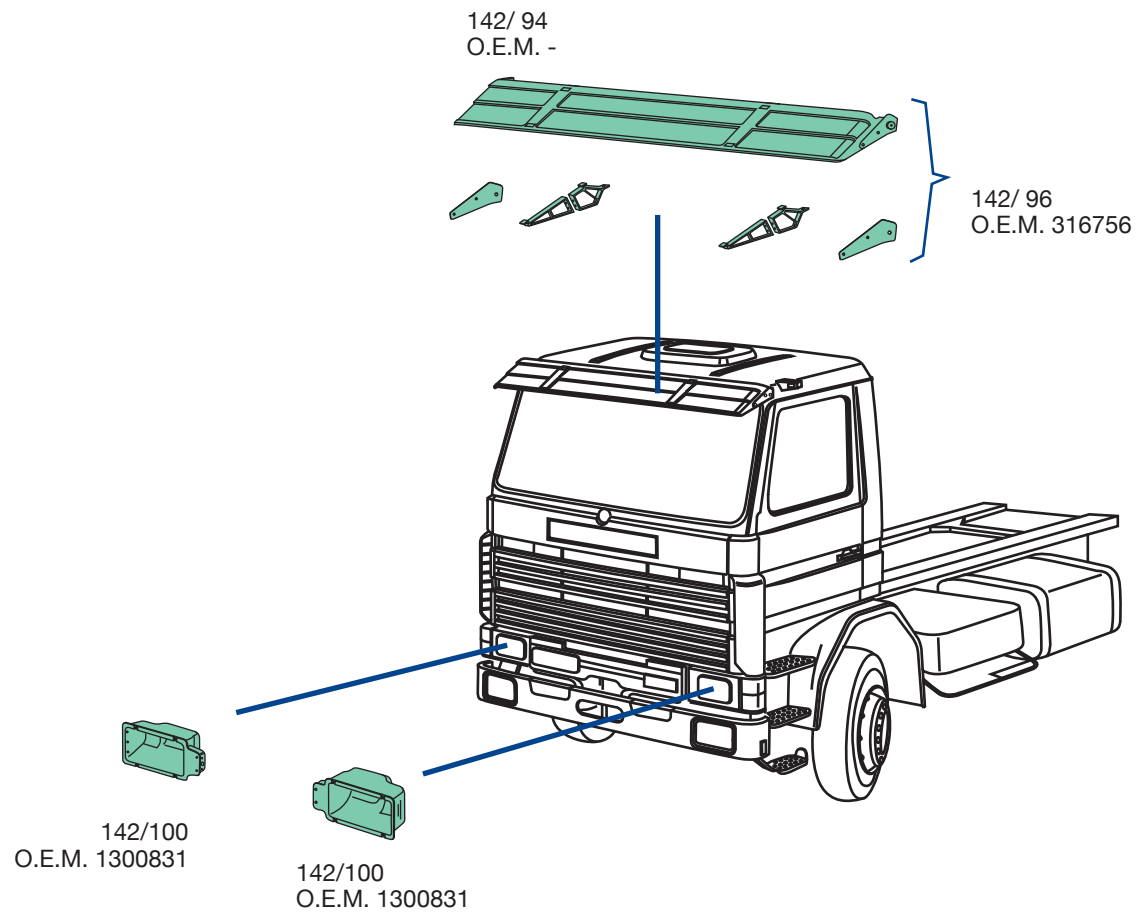

SCANIA 142 CR

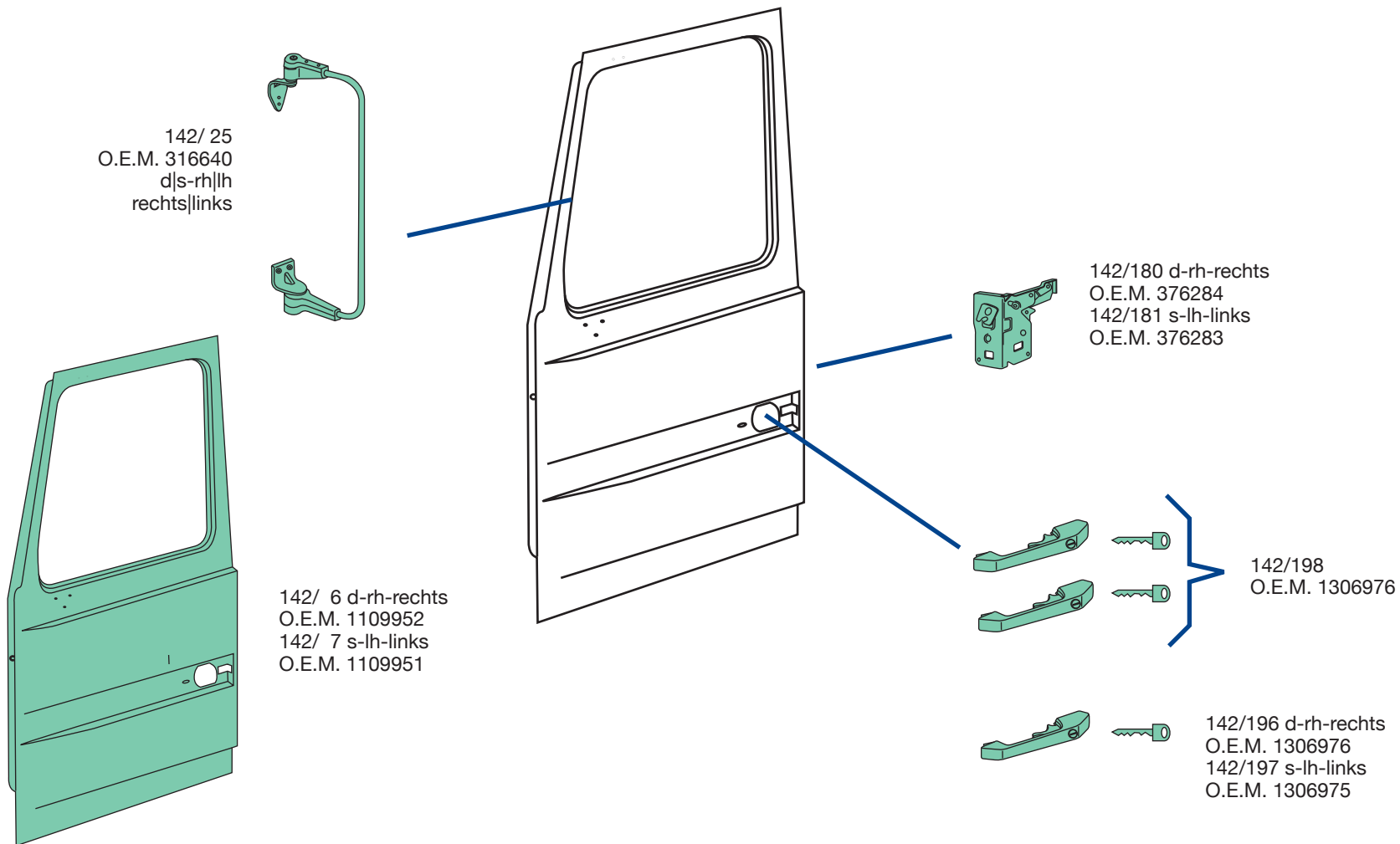

SCANIA 142 CR

142/182 d-rh-rechts
O.E.M. 296834
142/183 s-lh-links
O.E.M. 296833

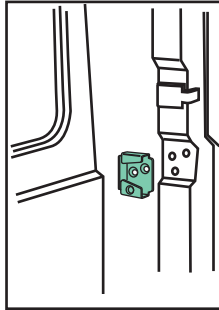

142/177
O.E.M. 524533
d|s-rh|lh-rechts|links

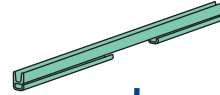

142/170
O.E.M. 356540
d|s-rh|lh-rechts|links

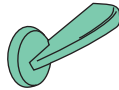

142/166
O.E.M. 376116
d|s-rh|lh-rechts|links



142/ 9
O.E.M. 356942
d|s-rh|lh-rechts|links



142/164 d-rh-rechts
O.E.M. 524784
142/165 s-lh-links
O.E.M. 524783

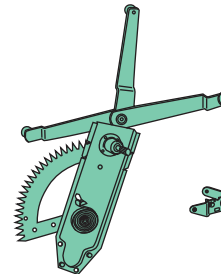

142/174 d-rh-rechts
O.E.M. 524796
142/175 s-lh-links
O.E.M. 524795

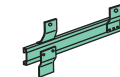

142/172
O.E.M. 336938
d|s-rh|lh-rechts|links



applicabile a | suitable to | verwendbar für:

SCANIA 142 CR

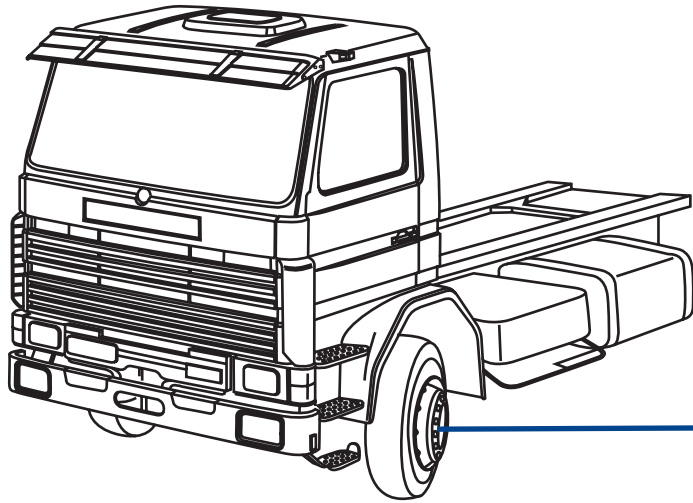

930/033
O.E.M. -

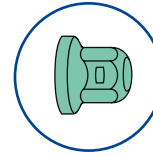

930/001 d-rh-rechts
O.E.M. -
930/002 s-lh-links
O.E.M. -



930/200
O.E.M. -
d|s-rh|lh
rechts|links

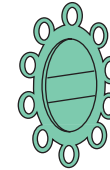

930/100 d-rh-rechts
O.E.M. -
930/101 s-lh-links
O.E.M. -

930/033 - Tappo copri Bullone - Bolt cover - Radmutterkappen

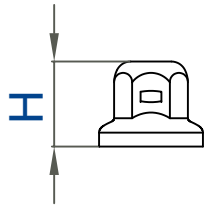

H	45 mm
Per bulloni \varnothing - bolt \varnothing	33 mm
Schlüsselweite \varnothing	
Colore	cromato-chrome-verchromt
Colours-Farbe	
Materiale-Material	acciaio inox-stainless steel Edelstahl
Kg	0,025

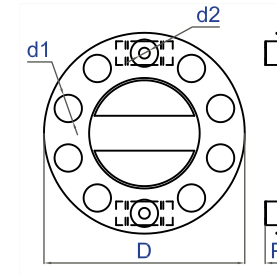

930/001 d-rh-rechts - 930/002 s-lh-links

D \varnothing 425 mm	P 50 mm
d1 nr. 10	d1 \varnothing 58 mm
d2 nr. 2	d2 \varnothing 23 mm
Ventilata	si-yes-Ja
Ventilated-Belüftet	
Colore	cromato e nero-chrome and black
Colours-Farbe	verchromt und schwarz
Materiale-Material	acciaio inox e plastica stainless steel and plastic Edelstahl und Kunststoff
Kg	1,230

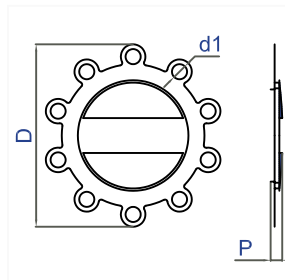

930/100 d-rh-rechts - 930/101 s-lh-links

D \varnothing 387 mm	P 30 mm
d1 nr. 10	d1 \varnothing 32 mm
Ventilata	si-yes-Ja
Ventilated-Belüftet	
Colore	cromato e nero-chrome and black
Colours-Farbe	verchromt und schwarz
Materiale-Material	acciaio inox e plastica stainless steel and plastic Edelstahl und Kunststoff
Kg	0,655

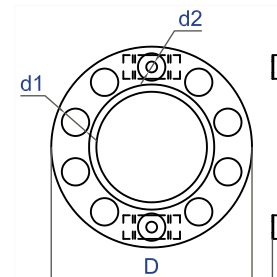

930/200 d|s-rh|lh-rechts|links

D \varnothing 425 mm	P 40 mm
d1 nr. 10	d1 \varnothing 58 mm
d2 nr. 2	d2 \varnothing 23 mm
Ventilata	no-nein
Ventilated-Belüftet	
Colore	cromato-chrome-verchromt
Colours-Farbe	
Materiale-Material	acciaio inox-stainless steel Edelstahl
Kg	1,155

applicabile a | suitable to | verwendbar für:

SCANIA 142 CR

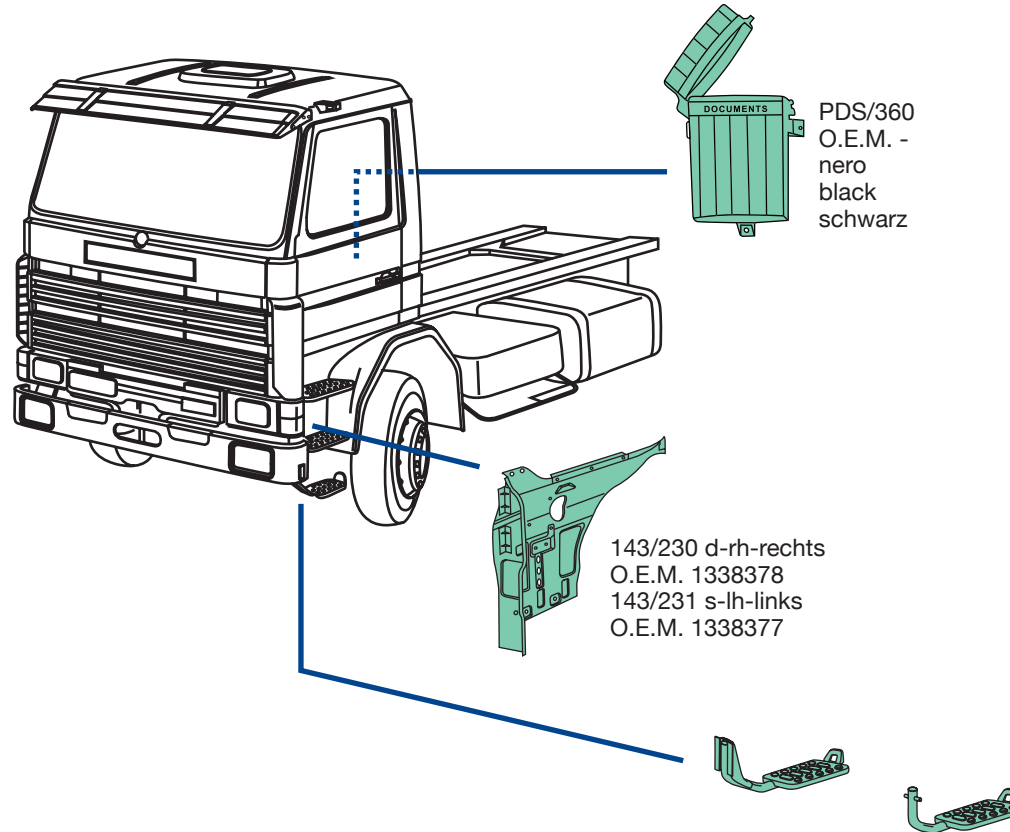

PDS/360

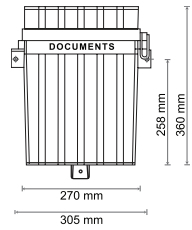

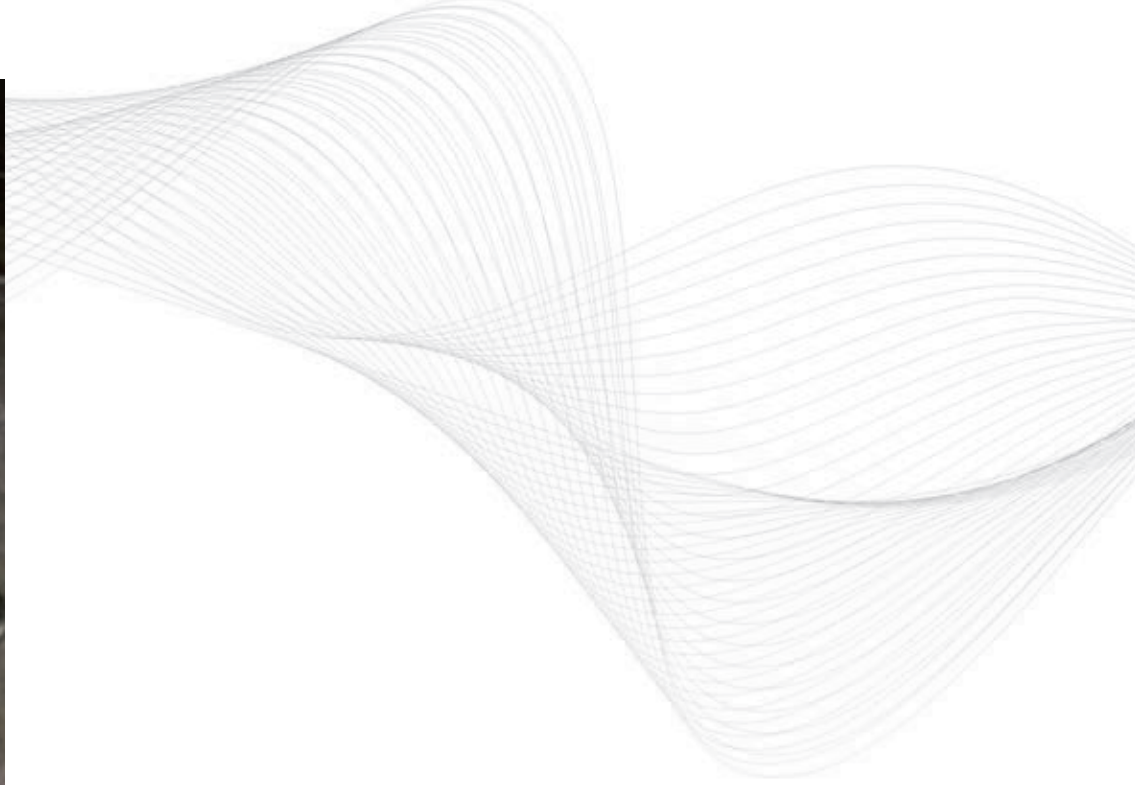

IT Stampo in acciaio per la produzione della sede faro sinistro
EN Hardened steel mould for lh headlamp rim production
DE Stahlform fuer die Produktion vom Scheinwerfergehaeuse links



- IT Stampo in acciaio per la produzione bavette per deviatori aria Scania.
EN Steel mould for the production of the air in take of Scania.
DE Stahlform für die Herstellung von Windabweisern für Scania.



IT Stampo in acciaio per la produzione deviatori aria Scania.

EN Steel mould for the production of air baffles of Scania.

DE Stahlform für die Herstellung von Luftleitblechen für Scania.

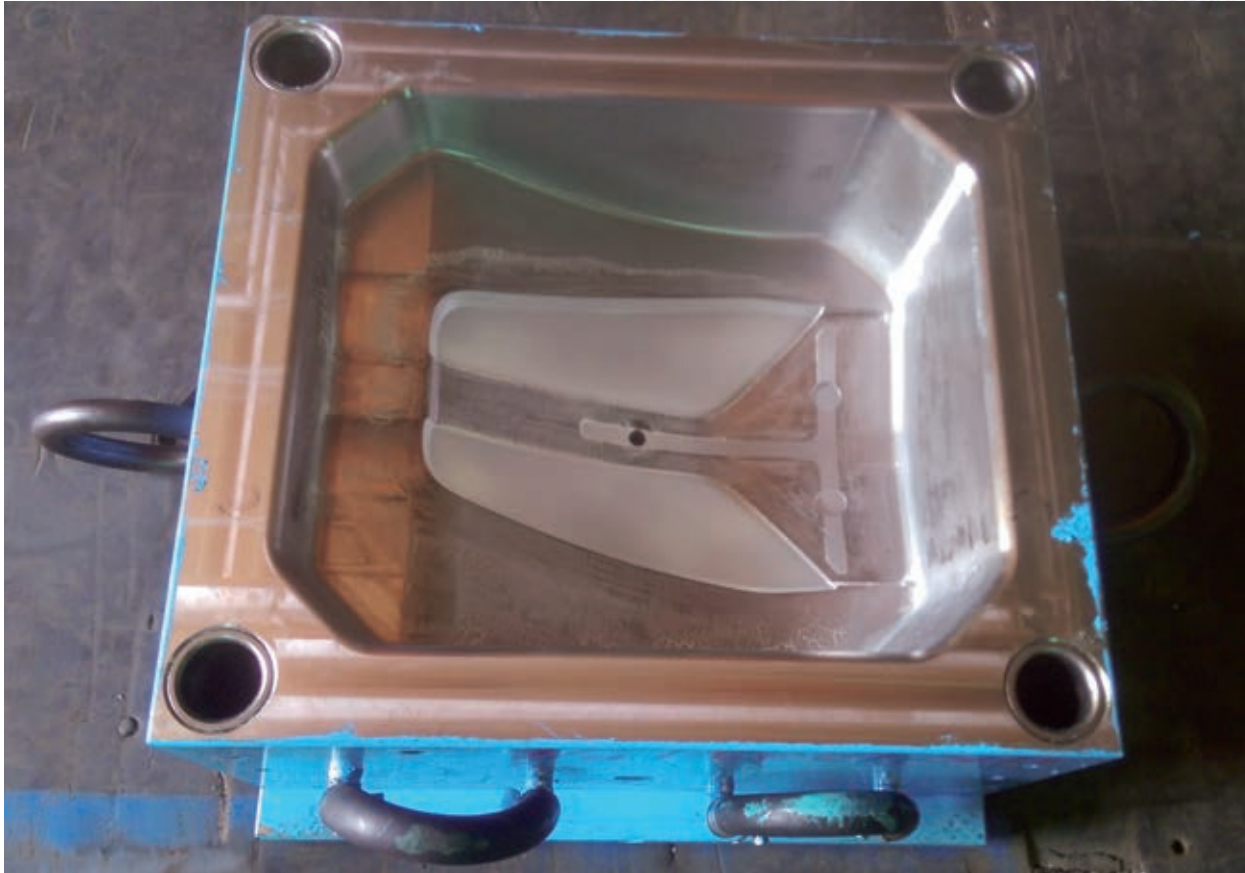

- IT Stampo in acciaio per la produzione modanatura per bavette Scania.
EN Steel mould for the production of air deflector element Scania.
DE Stahlform für die Herstellung von Luftleitelementen für Scania

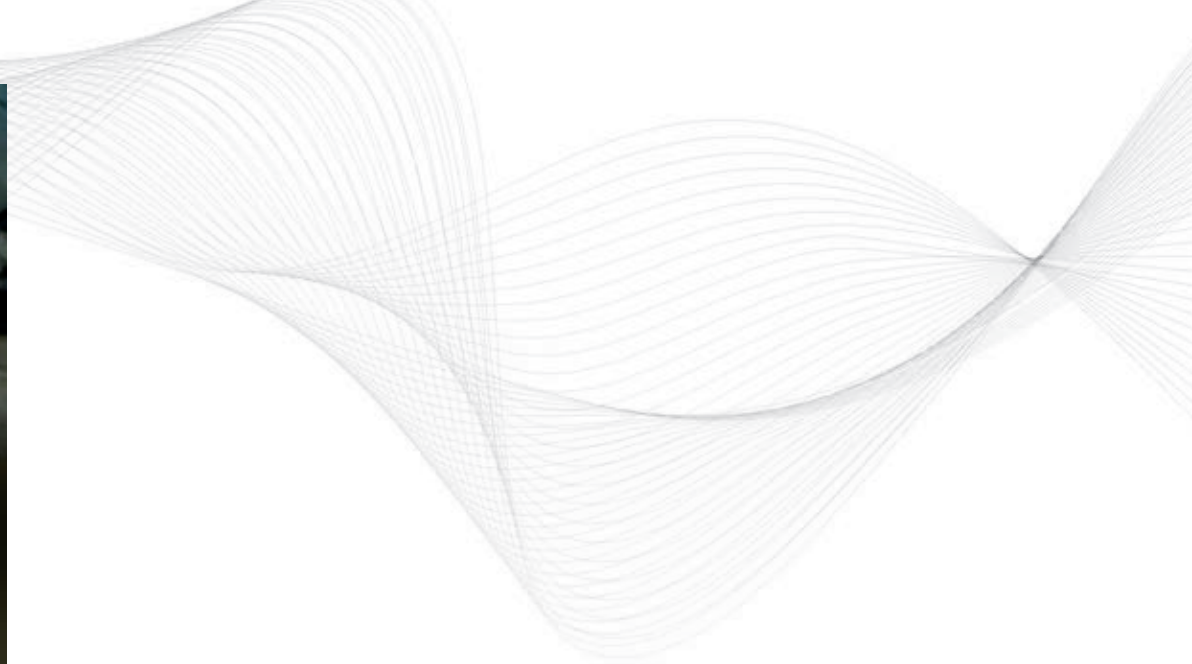

- IT Sagoma in polistirolo per costruzione stampo estensione porta destra
EN EPS profile for the construction of the mould for the right side door extension
DE Polystyrolschlabone für den Formbau der Türverlängerung

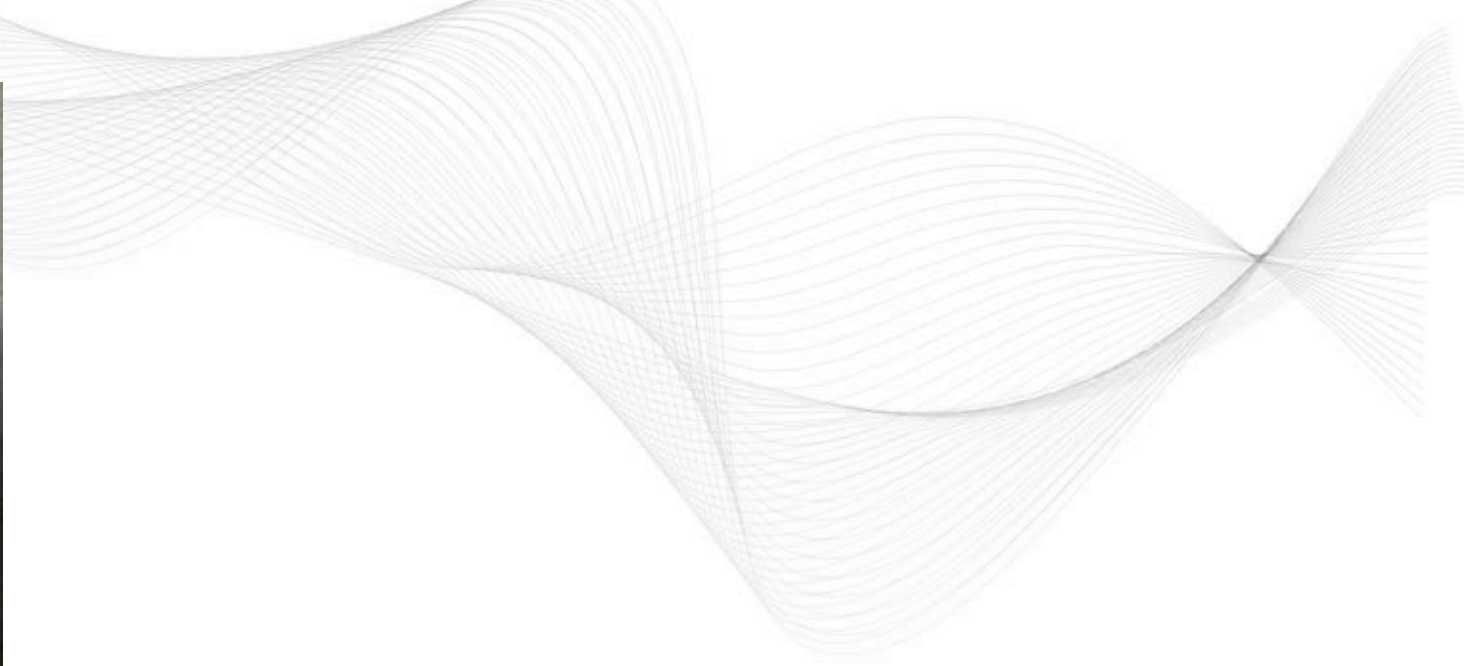

- IT Stampo in acciaio per la produzione di un paraurti.
EN Steel mould for the production for bumper.
DE Stahlwerkzeug für Stoßstangenfertigung.



- IT Maschera di controllo per le porte Scania SCR/ 2 e SCR/ 3
EN Checking Jig for Scania Doors SCR/ 2 and SCR/ 3
DE Überprüfung der Scania (SCR/2 und SCR/3) Türen auf Paßgenauigkeit.



IT Robot di foratura e taglio laser
EN Drilling robot and laser cutting
DE Läserbohrer und Schneiderroboter



IT Robot di foratura e taglio visiera parasole
EN Sunvisors drilling and cutting robot
DE Bohr- und Schnittrrobot für Sonnenblende

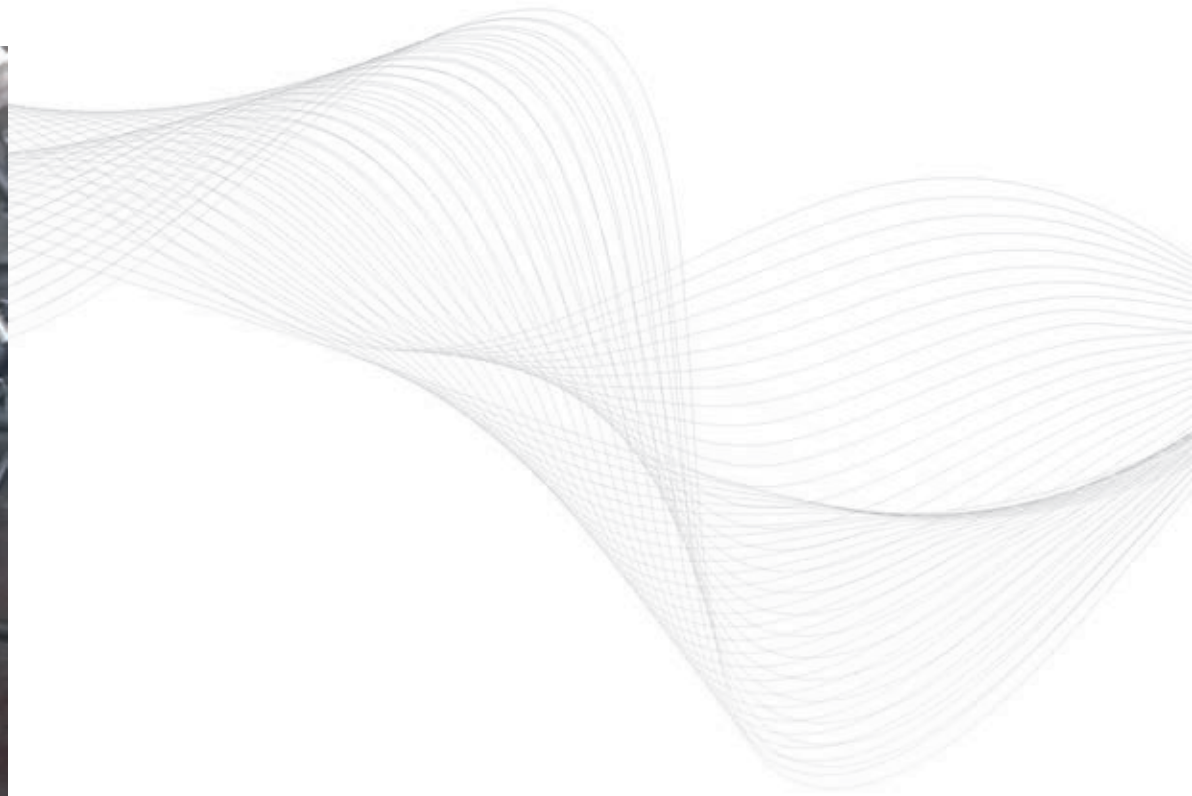



IT Stampo in acciaio per la produzione di una calotta posteriore
EN Hardened steel mould for rear top guard production
DE Stahlform fuer die Produktion von Kotfluegel



COVIND SPA

SERVIZIO VENDITE ITALIA
DOMESTIC SALES DPT.

 +39 011 8965702

 +39 011 8965714

 +39 011 8965719

 +39 011 8965756

E.MAIL vendite@covind.it

SERVIZIO VENDITE ESTERO
INTERNATIONAL SALES DPT.

 +39 011 8965722

 +39 011 8965735

 +39 011 8965759

 +39 011 8005149

E.MAIL export@covind.it

COVIND S.P.A.

Strada della Cebrosa, 68-70-72

10036 Settimo Torinese (TO) - ITALY

☎ +39 011 8965711

☎ +39 011 8977830

✉ marketing@covind.it

www.covind.it



COVIND COV
IND COVIND
COVIND COV
IND COVIND
COVIND COV
IND COVIND
COVIND COV

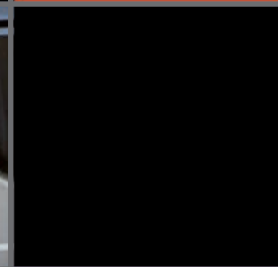
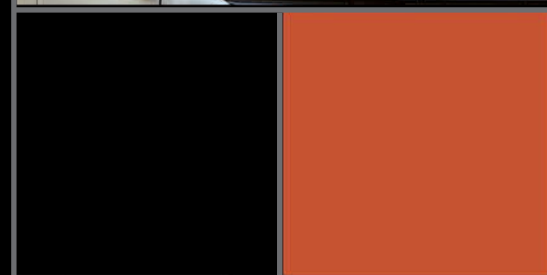

MOD7SCA02